

Designer Collection Specifications

Air-Whirlpool - MA635

Madeline™

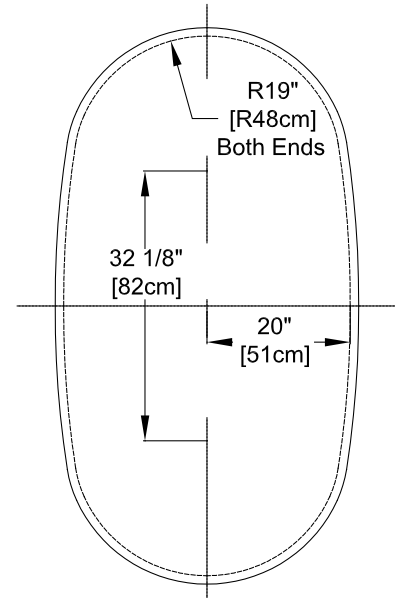
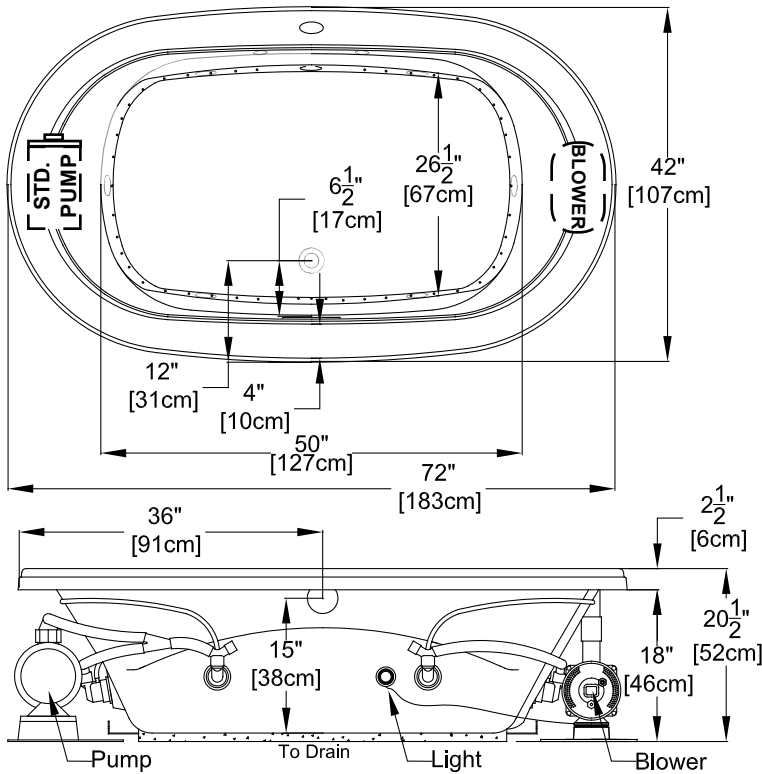

Drop In Hole Size

Patents received or pending.

Note: Dimensional Tolerances: ±1/4"

Note: The pump and blower extend approximately 1" past the end radius of the bath. This requires angling the bath into the drop-in hole.

- Drop-in-Hole Size:** See Diagram
- Operating Capacity:** 53 Gal.
- Overflow Capacity:** 77 Gal.
- Floor Loading / sq.ft.:** 52.2 lbs.
- Carton Weight:** 205 lbs.
- Cube:** 43.2 ft.³

Construction: Fiberglass reinforced acrylic bath with Level Form™ full-support base.

We provide products listed with Intertek ETL SEMKO (Edison Testing Laboratories) U.S. and Canadian and with International Association of Plumbing and Mechanical Officials (IAPMO). Consult factory with your listing requirements.

Standard		<p>A 120V system that includes a quiet 1-1/2 HP, 1-speed whirlpool pump, a 1HP, variable speed air blower with integral air heater; automatic purge cycle; an electronic control with a low water level sensor to prevent the pump from operating without water; and a 20-minute timer. Control keypad operates the pump, blower and blower speed for continuous, pulse or wave massage modes. The keypad also operates the optional LED Chromatherapy mood light.</p>
Premier		<p>A 120V system that includes a whisper quiet 1-1/2 HP, 1-speed combination whirlpool pump/heater, a 1HP, variable speed air blower with integral air heater, Chromatherapy Mood Light, Automatic Ozone System; automatic purge cycle; an electronic control with a low water level sensor to prevent the pump from operating without water; and a 20-minute timer. Control keypad operates the pump, blower and blower speed for continuous, pulse or wave massage modes. The keypad also operates the LED Chromatherapy mood light.</p>
Signature		<p>A 240V system that includes a quiet 1-1/2 HP, 3-speed whirlpool pump, a 1HP, variable speed air blower with integral air heater, Chromatherapy mood light, Automatic Ozone System, Automatic 1.5kW Heater; automatic purge cycle; a digital control with LCD display window; low water level and water temperature sensors to ensure proper operation; and a 20-minute timer. Control keypad operates the pump, blower and blower speed for continuous, pulse or wave massage modes, LED Chromatherapy mood light, optional jetted neck pillow (on Designer baths) and shows pump status, blower speed, water temperature and time remaining. Includes a floating Universal Remote Control that operates all functions of blower and LED Chromatherapy mood light plus TV, DVD, CD, etc.</p>