

## Integrity<sup>®</sup> Collection Specifications

# AirMasseur<sup>®</sup> - B3260

### with Integral Tile Lip

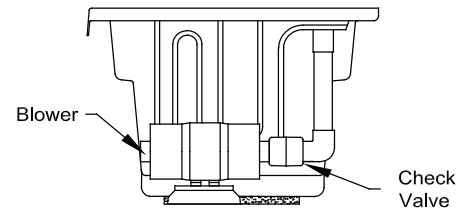
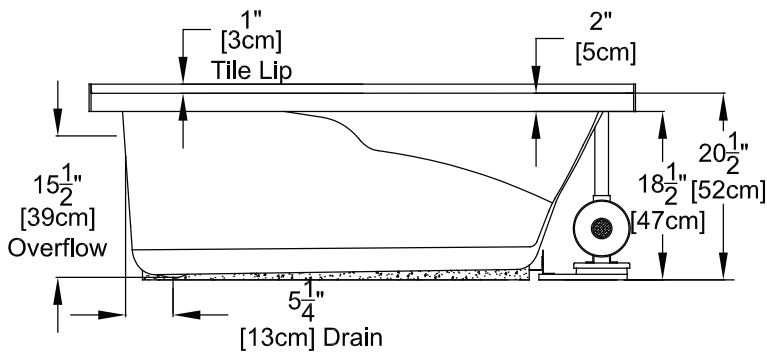
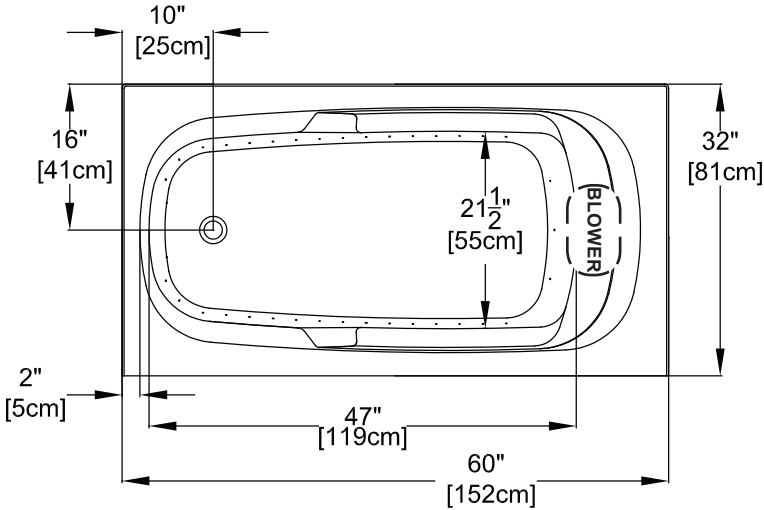

Patents received or pending.

Note: Dimensional Tolerances: ±1/4"

<b>Drop-in-Hole Size:</b>	N/A
<b>Operating Capacity:</b>	32 Gal.
<b>Overflow Capacity:</b>	52 Gal.
<b>Floor Loading / sq.ft.:</b>	49.1 lbs.
<b>Carton Weight:</b>	107 lbs.
<b>Cube:</b>	28.1 ft. <sup>3</sup>

Air Switch Control

Includes a quiet, 120v, 1HP, variable speed air blower with an integral air heater, 20-minute timer and automatic purge cycle. Air switch operates the on/off and speed functions of the blower. Requires (1) 15A, 120v GFCI protected circuit.

**Construction:** Reinforced Acrylic shell mounted on Level Form™ pre-leveled full support base.

*We provide products listed with Intertek ETL SEMKO (Edison Testing Laboratories) U.S. and Canadian and with International Association of Plumbing and Mechanical Officials (IAPMO). Consult factory with your listing requirements.*