

## Integrity<sup>®</sup> Collection Specifications

# Whirlpool & Soaking - A6060

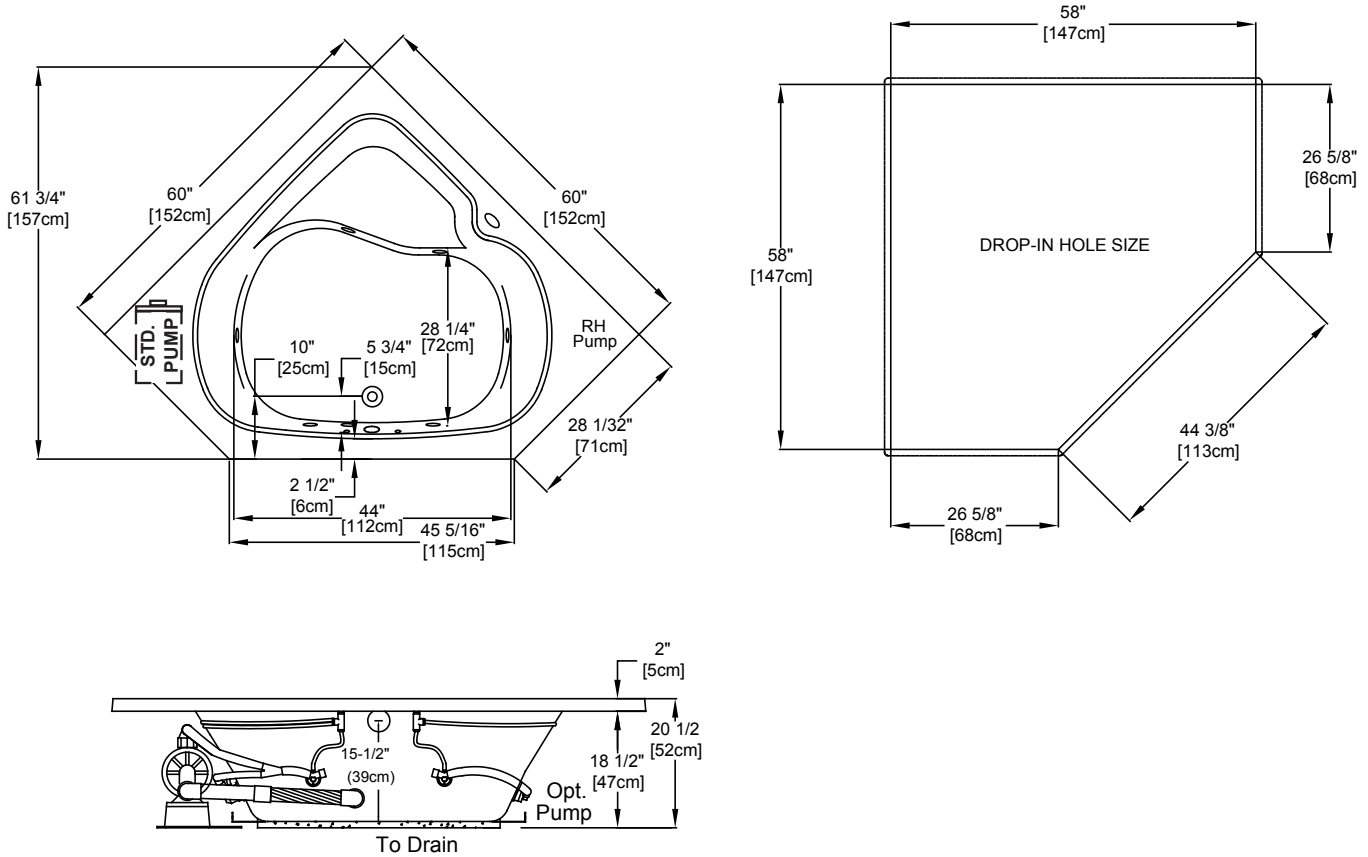

Patents received or pending.

Note: Dimensional Tolerances: ±1/4"

<b>Drop-in-Hole Size:</b>	See Diagram
<b>Operating Capacity:</b>	53 Gal.
<b>Overflow Capacity:</b>	81 Gal.
<b>Floor Loading / sq.ft. (WP/ Soaking):</b>	42.4/ 39.7 lbs.
<b>Carton Wt. (WP/Soaking):</b>	140/ 93 lbs.
<b>Cube:</b>	50.9 ft. <sup>3</sup>

Air Switch Control



Includes a quiet, 120v, 1HP, 1-speed pump and an air switch on/off control. Requires (1) 20A, 120v GFCI protected circuit.

**Construction:** Reinforced Acrylic shell mounted on Level Form™ pre-leveled full support base.

*We provide products listed with Intertek ETL SEMKO (Edison Testing Laboratories) U.S. and Canadian and with International Association of Plumbing and Mechanical Officials (IAPMO). Consult factory with your listing requirements.*