



Install the Guardian and RELAX!

When the power goes out, the Guardian takes over!



GUARDIAN

Emergency Back Up Sump Pump

Model 747H20

The Guardian consists of all components outlined in blue

Backflow Preventer (Optional)

Discharge

Discharge Check Valve

Inlet Check Valve

Mechanically activated diaphragm valve ensures positive on/positive off, with no water wasted.

Water Inlet

Separate discharges are recommended.

Mechanical Float

Discharge

Mounting Bracket

Specially weighted float ensures positive off. Will not get stuck in the open position. Never wastes water.

Specially designed Jet Ejector provides optimal performance

Here's How It Works...

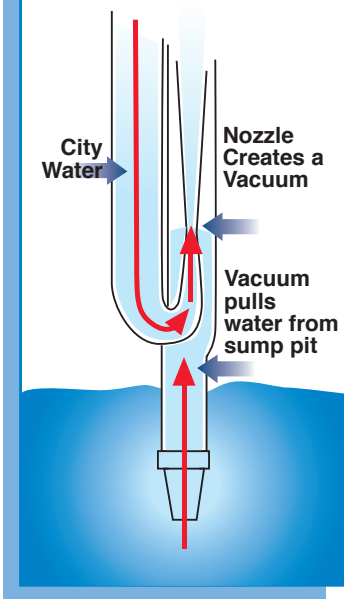

Non-corrosive suction screen

Existing Sump Basin

Existing Sump Pump



PUMPS | WATERWORKS | PLUMBING VALVES | GAS VALVES

A.Y. McDonald Mfg. Co.



800.292.2737 | FAX 800.832.9296 | pumps@aymcdonald.com | www.aymcdonald.com

Here's How The Guardian® Works...

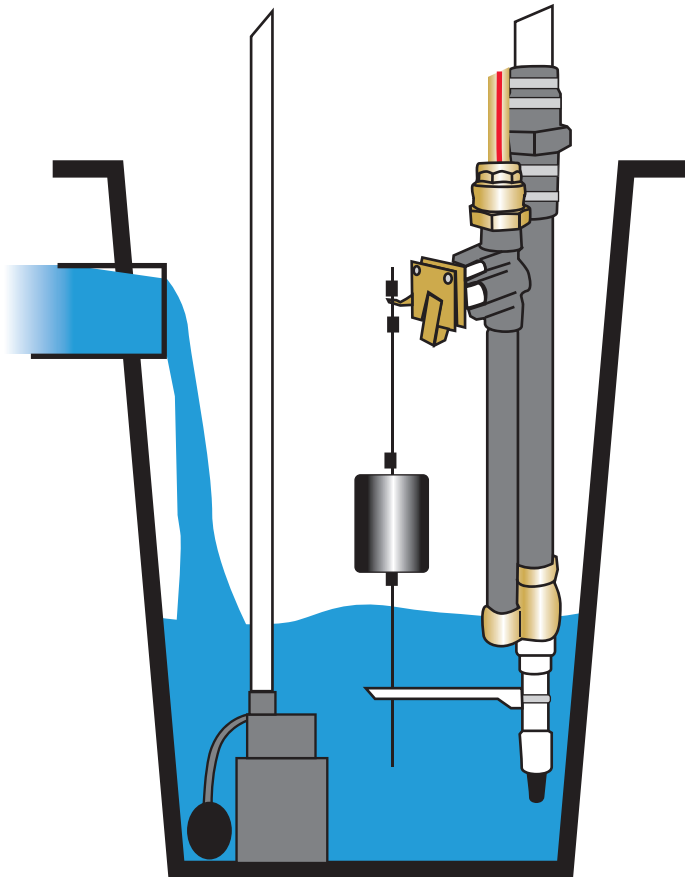

Sump pump failure

A standard, electric sump pump is designed for occasional use with clean rain water. Heavy storms can generate a large volume of water, which the pump cannot handle. Power outages can cause them to fail altogether.

Without the sump pump running, the water level in the sump pit will rise.

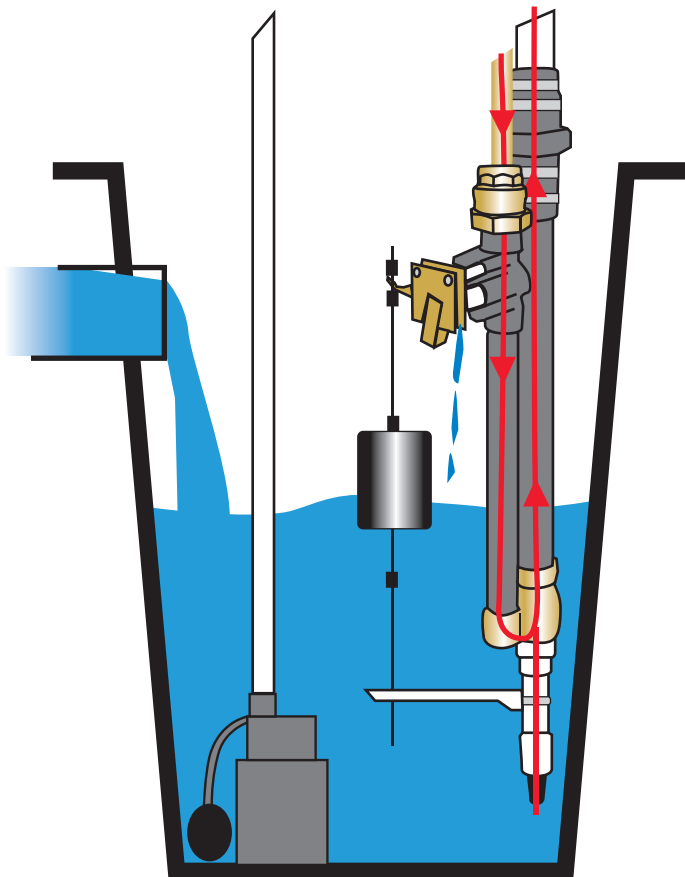

Guardian® takes over

The rising water level causes the specially designed float to rise, mechanically activating the diaphragm valve. Using a vacuum created in the ejector, water is siphoned out of the pit, protecting your property.

The patented Guardian® provides the ultimate security for the most valuable asset you have - your home.

Here's How The Guardian® Works...

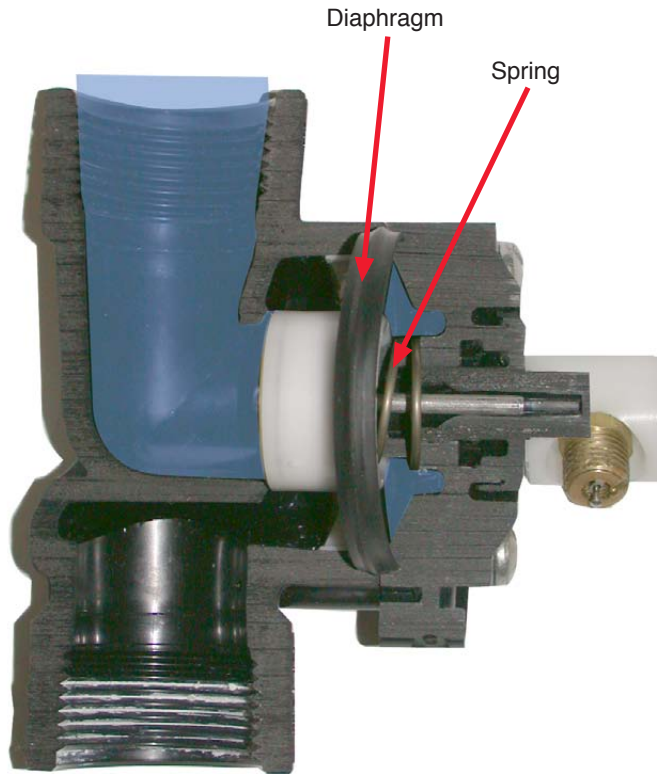

Diaphragm Valve CLOSED

The diaphragm valve is controlled by the pressure on either side of the diaphragm. Pressure is equalized on both sides of the valve, due to an orifice between the two chambers.

When pressure is equal, a spring causes the diaphragm to close off the waterway.

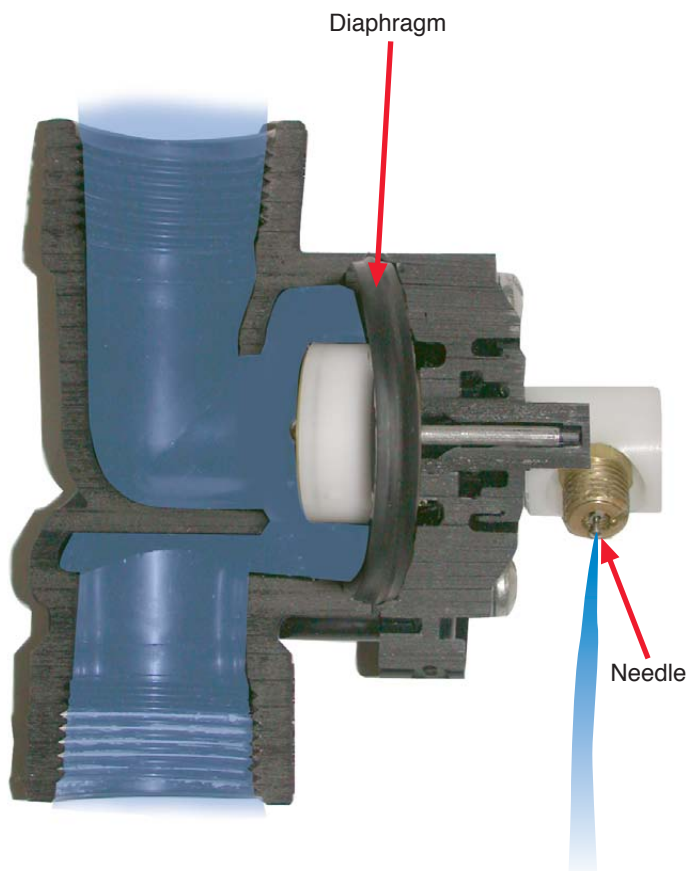

Diaphragm Valve OPEN

As the float rises, it activates the the operating valve, depressing the needle on the diaphragm valve.

Water streams out of the needle, relieving the pressure in the rear chamber of the valve. This relief opens the valve, allowing water to flow through the ejector and pull water out of the sump pit.

When the float goes down, the needle is released and water accumulates behind the diaphragm. The pressure builds behind the diaphragm and causes it to close the waterway, stopping the pump from running.

Guardian[®] Frequently Asked Questions

What makes the Guardian different from other emergency pumps?

The Guardian is a water powered pump which means that it does not require any external power source (battery, electricity, or generator). Even though there are other water powered pumps on the market, only the Guardian has its exclusive patented design that ensures maximum performance, the most reliable switch mechanism, and an operating valve that ensures the pump will turn on when you need it and stay off when you don't.

Why not use a battery backup system?

Unfortunately batteries can not be relied upon to be ready to go and reliable 100% of the time. Anyone who has been stranded due to a dead car battery can certainly relate to this problem. In addition, a battery will only last so long, sometimes less than the duration of a power outage. Even systems where homeowners regularly replace the expensive marine batteries for their pumps experience failures due to the battery system being inadequate.

Why does the Guardian have a backflow device?

The Guardian is furnished with a single check valve. This check valve protects your household water system. It ensures that no water can be siphoned from the sump pit back into the water supply line. For additional protection, an RPZ device is recommended and may be required by local code.

What kind of pressure do I need?

The Guardian performs optimally between the pressures of 29 and 90 PSI. This pressure range accommodates most homes. As a guideline, if you turn on the shower in a home at full flow and then turn on another faucet, there should be no noticeable change in the water pressure streaming from the shower head. Any noticeable reduction in flow or pressure is an indication that you may have inadequate water pressure.

Do I need a special lid for my sump?

No, a hole is typically cut in the lid to accommodate the Guardian pump and the stream of water that comes from the valve when the pump is operating.

Can I use the same discharge pipe as my standard sump pump?

The practice of using the same discharge is done in some installations however it is strongly recommended that a separate discharge line be run for the Guardian. If the main sump pump discharge line is blocked, the Guardian will be sure to run when it has it's own discharge. Separate lines also protect against the discharge water from the Guardian leaking back through the check valve of the sump pump.

My pump weeps water when it is running. Is this normal?

Yes, the water streaming from the Guardian valve is normal and will continue while the pump runs and for 15-30 seconds after the pump shuts off.

Can I use the Guardian as my primary pump?

The Guardian[®] is a Back-up sump pump. A primary pump is required.

Where can I get a Guardian Pump?

The Guardian is a product that should be installed in accordance with local plumbing codes and is therefore sold through plumbing wholesalers to licensed plumbers. Contact your local plumber or plumbing wholesaler and inform them that you want the Guardian.

How much water will the Guardian pump?

The amount of water removed from the sump depends on the pressure of the incoming water and the vertical lift of the discharge pipe. Please see the table below.

Performance in GPH

	FEET of LIFT							No Water Removed No Flow At:
	5'	7'	9'	12'	15'	18'	21'	
30	480	420	360	228	192	0	0	18'
40	672	594	558	468	396	324	246	26'
60	750	750	750	750	750	750	750	40'