



Air Conditioning & Heating

CPG COMMERCIAL

COOLING CAPACITY: 90,000 — 118,000 BTU/H

HEATING CAPACITY: 168,000 BTU/H

THREE-PHASE

7½- TO 12½-TON

SELF-CONTAINED PACKAGED

GAS/ELECTRIC UNITS

UP TO 11.5 EER

80% AFUE

Standard Features

- R-410A chlorine-free refrigerant
- TuffTube™ tubular heat exchanger
- High-efficiency scroll compressor
- Two-stage heating / two-stage cooling
- Copper tube / aluminum fin coils
- Contactor with lugs
- High-capacity, steel-cased filter dryer
- Single-point entry
- 24-volt terminal strip
- Convertible
- Easy to service
- Built-in filter rack with standard 2" filters
- Bottom utility entry
- Complies with California NOx emissions standards
- AHRI Certified; ETL Listed

Cabinet Features

- Heavy-gauge, galvanized-steel cabinet with UV-resistant powder-paint finish
- Full Perimeter Rail
- Curb Fit



Contents

Nomenclature 2

Product Specifications 3

Expanded Cooling Data 7

Airflow Data 16

Dimensions 21

Wiring Diagrams 25

Accessories 30



* Complete warranty details available from your local dealer or at www.goodmanmfg.com.



NOMENCLATURE

	C	P	G	090	090	3	B	X	X	X
	1	2	3	4,5,6	7,8,9	10	11	12	13	14
Brand										
C Commercial										
Configuration										
P Packaged Unit										
Application										
C Cooling										
G Gas Heat										
H Heat Pump										
Nominal Gross Cooling Capacity										
036 3 Tons	102	8½ Tons								
048 4 Tons	120	10 Tons								
060 5 Tons	150	12½ tons								
072 6 Tons	180	15 Tons								
090 7½ Tons	240	20 Tons								
Nominal Heating Capacity										
CPG	CPC/CPH (Factory-Installed Electric Heat)									
045 45,000 BTU/h	XXX	No Heat								
090 90,000 BTU/h	010	10 kW	030	30 kW						
115 115,000 BTU/h	015	15 kW	031	30 kW						
140 140,000 BTU/h	016	15 kW	045	45 kW						
210 210,000 BTU/h	018	18 kW	046	45 kW						
350 350,000 BTU/h	020	20 kW	060	60 kW						
400 400,000 BTU/h	025	25 kW	075	75 kW						
Voltage										
1 208V 1-Phase	4	460V 3-Phase								
2 220/240V 1-Phase 50 Hz	5	380/415V 3-Phase 50 Hz								
3 208/230V 3-Phase	7	575V 3-Phase								
Factory-Installed Options										
<ul style="list-style-type: none"> Condenser Hail Guards: Louvered metal guards help protect the condenser coil from damage from hail and debris. Available as a factory-installed option on 3- to 12½-ton units. Hail guards are standard on 15- and 20-ton units. Stainless-Steel Heat Exchanger (CPG units only): A tubular heat exchanger made of 409-type stainless steel is installed in the unit. Ultra-Gold Condenser Coil: Offers increased corrosion resistance of the condenser coil. Low-Ambient Kit: Allows for cooling operation at lower outdoor temperatures. On the 3- to 6-ton units, cooling operation is extended from 60°F ambient temperature to 35°F outside air temperature. On 7½- to 20-ton units, cooling operation is extended from 35°F ambient temperature to 0°F outside air temperature. Economizers (Downflow): Based on air conditions, can provide outside air to cool the space. High Static Kits: Provides airflow in higher static applications. Electric Heat Kits (CPC and CPH units only): Available in all voltage options. Non-powered Convenience Outlet: A 120V, 15A, GFCI outlet makes it easier for technicians to service the unit once an electrician runs power to the outlet. Powered Convenience Outlet: A 120V, 15A, GFCI outlet powered with a transformer built into the unit. 										



PRODUCT SPECIFICATIONS — 7½ TONS

	A Models		B Models		
	CPG090 ***3B***	CPG090 ***4B***	CPG090 ***3B***	CPG090 ***4B***	CPG090 ***7B***
Cooling Capacity					
Total BTU/h	90,000	90,000	90,000	90,000	90,000
Sensible BTU/h	65,700	65,700	64,000	64,000	64,000
EER / IEER	11.5 / 11.5	11.5 / 11.5	11.5/11.5	11.5/11.5	11.5/11.5
Decibels	82.0	82.0	82.0	82.0	82.0
AHRI Reference #s	3000985	3000985	3620222	3620222	3620222
Heating Capacity					
High Input / Output BTU/h	210,000/ 168,000	210,000/ 168,000	210,000/ 168,000	210,000/ 168,000	210,000/ 168,000
Low Input / Output BTU/h	157,500/126,000	157,500/126,000	157,500/126,000	157,500/126,000	157,500/126,000
Steady-State Efficiency (AFUE)	80	80	80	80	80
Temperature Rise Range (°F)	35	35	35	35	35
No. of Burners	6	6	6	6	6
Evaporator Motor / Coil					
Motor Type	Belt Drive	Belt Drive	Belt Drive	Belt Drive	Belt Drive
Indoor Nominal CFM	3,000	3,000	3,000	3,000	3,000
FLA (Cooling)	5.0	2.5	5.0	2.5	2.3
Horsepower / RPM	1½ / 1725	(4) 1½ / 1725	1½ / 1745	1½ / 1745	1½ / 1725
Piston Size (Cooling)	0.076	0.076	0.078	0.078	0.078
Filter Size (Qty)	(4) 16" x 24" x 2"	(4) 16" x 24" x 2"	(4) 16" x 20" x 2"	(4) 16" x 20" x 2"	(4) 16" x 20" x 2"
Drain Size (NPT)	¾"	¾"	¾"	¾"	¾"
R-410A Refrigerant Charge: Cir #1 / #2 (oz.)	215 / 215	215 / 215	175 / 175	175 / 175	175 / 175
Evaporator Coil Face Area (ft²)	10.2	10.2	8.9	8.9	8.9
Rows Deep / Fins per Inch	4 / 16	4 / 16	4 / 16	4 / 16	4 / 16
Belt Drive Evap Fan Data					
# of Wheels (D x W)	1 (15" x 12")	1 (15" x 12")	1 (15" x 12")	1 (15" x 12")	1 (15" x 12")
Motor / Blower Sheave	VL40 / AK74	VL40 / AK74	VL40 / AK74	VL40 / AK74	VL40 / AK74
Belt	AX51	AX51	AX51	AX51	AX51
Condenser Fan / Coil					
Quantity of Condenser Fan Motors	2	2	2	2	2
Horsepower - RPM	¼ - 1090	¼ - 890	¼ - 1075	¼ - 890	¼ - 1075
Fan Diameter / # Fan Blades	22 / 4	22 / 4	22 / 4	22 / 4	22 / 4
Outdoor Nominal CFM	7,600	7,600	7,600	7,600	7,600
Face Area (ft²)	32.4	32.4	26.5	26.5	26.5
Rows Deep / Fins per Inch	2 / 20	2 / 20	2 / 22	2 / 22	2 / 22
COMPRESSOR					
Quantity / Type	2 / Scroll	2 / Scroll	2 / Scroll	2 / Scroll	2 / Scroll
Stage	1	1	1	1	1
Electrical Data					
Voltage / Phase / Frequency	208-230 / 3 / 60	460 / 3 / 60	208-230 / 3 / 60	460 / 3 / 60	575 / 3 / 60
Compressor RLA / LRA	13.1 / 83.1	6.1 / 41.0	13.1 / 83.1	6.1 / 41.0	4.4 / 33.0
Indoor Blower HP / FLA	1.5 / 5.0	1.5 / 2.5	1.5 / 5.0	1.5 / 2.5	1.5 / 2.3
Max External Static	1.5"	1.5"	1.5"	1.5"	1.5"
Outdoor Fan HP / RLA	¼ / 1.4	¼ / 0.8	¼ / 1.4	¼ / 0.8	¼ / 0.6
Total Unit Amps	34.1	16.3	34.0	16.3	12.3
Min. Circuit Ampacity ¹	37	18	37	18	13
Max. Overcurrent Protection (amps) ²	50	20	50	20	15
Entrance Power Supply & Control Voltage	Locating Dimple		Locating Dimple		
Operating Weight (lbs)	1210	1210	1030	1030	1030
Ship Weight (lbs)	1250	1250	1055	1055	1055

¹ Wire size should be determined in accordance with National Electrical Codes. Extensive wire runs will require larger wire sizes.

² May use fuses or HACR-type circuit breakers of the same size as noted.

Note: Always check the S&R plate for electrical data on the unit being installed.

PRODUCT SPECIFICATIONS — 8½ TONS

	CPG102 2103B***	CPG102 2104B***	CPG102 2107B***
COOLING CAPACITY			
Total, BTU/h	102,000	102,000	102,000
Sensible BTU/h	70,380	70,380	70,380
EER / IEER	11.3 / 11.2	11.3 / 11.2	11.3 / 11.2
Decibels	83	83	83
ARI Reference #s	3620221	3620221	3620221
HEATING CAPACITY			
High Input / Output BTU/h	210,000 / 168,000	210,000 / 168,000	210,000 / 168,000
Low Input / Output BTU/h	157,500/126,000	157,500/126,000	157,500/126,000
Steady State Efficiency	80	80	80
Temperature Rise Range (°F)	35 - 65	35 - 65	35 - 65
No. of Burners	6	6	6
EVAPORATOR MOTOR / COIL			
Motor Type	Belt Drive	Belt Drive	Belt Drive
Indoor Nominal CFM	3,400	3,400	3,400
Indoor Motor FLA (Cooling)	7.8	3.9	2.3
Horsepower - RPM	1725	1725	1725
Piston Size (Cooling)	0.08	0.08	0.08
Filter Size (Qty)	(4) 16" x 20" x 2"	(4) 16" x 20" x 2"	(4) 16" x 20" x 2"
Drain Size (NPT)	3/4"	3/4"	3/4"
R-410A Refrigerant Charge Cir #1 #2 (oz.)	180	180	180
Evaporator Coil Face Area (ft2)	8.9	8.9	8.9
Rows Deep / Fins per Inch	4 / 16	4 / 16	4 / 16
BELT DRIVE EVAP FAN DATA			
# of Wheels (D x W)	1 (15" x 12")	1 (15" x 12")	1 (15" x 12")
Motor Sheave / Blower Sheave	VL40 / AK74	VL40 / AK74	VL40 / AK74
Belt	AX51	AX51	AX51
CONDENSER FAN / COIL			
Quantity of Condenser Fan Motors	2	2	2
Horsepower - RPM	1/4" - 1090	1/4" - 890	1/4" - 1075
Fan Diameter / # Fan Blades	22 / 4	22 / 4	22 / 4
Outdoor Nominal CFM	7,600	7,600	7,600
Face Area (ft²)	13.25	13.25	13.25
Rows Deep / Fins per Inch	2 / 22	2 / 22	2 / 22
COMPRESSOR			
Quantity / Type	2 / Scroll	2 / Scroll	2 / Scroll
Stage	1	1	1
ELECTRICAL DATA / STATIC			
Voltage / Phase / Frequency	230 / 3 / 60	460 / 3 / 60	575 / 3 / 60
Compressor RLA / LRA ea.	14.5 / 98	6.3 / 55	6.0 / 41
Standard Max Static	1"	1	1
Outdoor Fan FLA ea.	1.4	0.8	0.6
Total Unit Amps	39.6	18.1	15.5
Min. Circuit Ampacity ¹	43.2	19.7	17
Max. Overcurrent Protection (amps) ²	50	25	20
Entrance Power Supply	Locating Dimple	Locating Dimple	Locating Dimple
Entrance Control Voltage			
OPERATING WEIGHT (LBS)	1030	1030	1030
SHIP WEIGHT (LBS)	1055	1055	1055

¹ Wire size should be determined in accordance with National Electrical Codes. Extensive wire runs will require larger wire sizes.

² May use fuses or HACR-type circuit breakers of the same size as noted.

Note: Always check the S&R plate for electrical data on the unit being installed.

PRODUCT SPECIFICATIONS — 10 TONS

	CPG120 ***3B***	CPG120 ***4B***	CPG120 ***7B***
COOLING CAPACITY			
Total BTU/h	118,000	118,000	118,000
Sensible BTU/h	87,300	87,300	87,300
EER / IEER	11.5 / 11.5	11.5 / 11.5	11.5 / 11.5
Decibels	83	83	83
ARI Reference #s	3023834	3023834	3023834
HEATING CAPACITY			
High Input / Output BTU/h	210,000 / 168,000	210,000 / 168,000	210,000 / 168,000
Low Input / Output BTU/h	157,500/126,000	157,500/126,000	157,500/126,000
Steady State Efficiency	80	80	80
Temperature Rise Range (°F)	25-55	25-55	25-55
No. of Burners	6	6	6
EVAPORATOR MOTOR / COIL			
Motor Type	Belt Drive	Belt Drive	Belt Drive
Indoor Nominal CFM	4,000	4,000	4,000
Indoor Motor FLA (Cooling)	7.8	3.9	2.5
Horsepower - RPM	2.0 - 1,725	2.0 - 1,725	2.0 - 1,725
Piston Size (Cooling)	0.086	0.086	0.084
Filter Size	(4) 16" x 24" x 2"	(4) 16" x 24" x 2"	(4) 16" x 24" x 2"
Drain Size (NPT)	¾"	¾"	¾"
R-410A Refrigerant Charge Cir #1 & 2 (oz.)	220 / 220	220 / 220	220 / 220
Evaporator Coil Face Area (ft²)	10.2	10.2	10.2
Rows Deep/ Fins per Inch	4 / 14	4 / 14	4 / 14
BELT DRIVE EVAP FAN DATA			
# of Wheels (D x W)	(1) 15" x 15"	(1) 15" x 15"	(1) 15" x 15"
Motor Sheave / Blower Sheave	VL40 / AK74	VL40 / AK74	VL40 / AK74
Belt	AX51	AX51	AX51
Rows Deep/ Fins per Inch	4/14	4/14	4/14
CONDENSER FAN / COIL			
Quantity of Condenser Fan Motors	2	2	2
Horsepower - RPM	½ - 1,075	½ - 1,075	½ - 1,075
Fan Diameter / # Fan Blades	22 / 3	22 / 3	22 / 3
Outdoor Nominal CFM	7,200	7,200	7,200
Face Area (ft²)	32.4	32.4	32.4
# Coils / Rows Deep - Fins per Inch	2 / 2 - 22	2 / 2 - 22	2 / 2 - 22
COMPRESSOR			
Quantity / Type / Stage	2 / Scroll / 1	2 / Scroll / 1	2 / Scroll / 1
Compressor RLA / LRA ea.	16 / 110.0	7.8 / 52.0	5.7 / 38.9
ELECTRICAL DATA			
Voltage/Phase/ Frequency	208-230/ 3/ 60	460/ 3/ 60	575/ 3/ 60
Belt-Driven Standard Max Static	1.4"	1.4"	1.4"
Outdoor Fan RLA ea.	2.40	1.20	0.90
Total Unit Amps	45	22	16
Min. Circuit Ampacity ¹	49	24	17
Max. Overcurrent Protection (amps) ²	60	30	20
Entrance Power Supply & Control Voltage	Locating Dimple		
OPERATING WEIGHT (LBS)	1235	1235	1235
SHIP WEIGHT (LBS)	1275	1275	1275

¹ Wire size should be determined in accordance with National Electrical Codes. Extensive wire runs will require larger wire sizes.

² May use fuses or HACR-type circuit breakers of the same size as noted.

Note: Always check the S&R plate for electrical data on the unit being installed.

PRODUCT SPECIFICATIONS — 12½ TONS

	CPG150 ***3B***	CPG150 ***4B***	CPG150 ***7B***
COOLING CAPACITY			
Total, BTU/h	146,000	146,000	146,000
Sensible BTU/h	102,200	102,200	102,200
EER / IPLV	10.8 / 11.2	10.8 / 11.2	10.8 / 11.2
Decibels	83	83	83
ARI Reference #s	3542681	3542681	3542681
HEATING CAPACITY			
High Input / Output BTU/h	210,000 / 168,000	210,000 / 168,000	210,000 / 168,000
Low Input / Output BTU/h	157,500/126,000	157,500/126,000	157,500/126,000
Steady State Efficiency	80	80	80
Temperature Rise Range (°F)	15 - 45	15 - 45	15 - 45
No. of Burners	6	6	6
EVAPORATOR MOTOR / COIL			
Motor Type (Belt Drive)	AX49	AX49	AX49
Indoor Nominal CFM	5,000	5,000	5,000
Indoor Motor FLA (Cooling)	9.4	4.7	4.2
Horsepower - RPM	3.0 - 1,725	3.0 - 1,725	3.0 - 1,725
Piston Size (Cooling)	0.096	0.096	0.096
Filter Size (Qty)	(4) 20" x 25" x 2"	(4) 20" x 25" x 2"	(4) 20" x 25" x 2"
Drain Size (NPT)	¾"	¾"	¾"
R-410A Refrigerant Charge Cir #1/ #2 (oz.)	285/ 285	285/ 285	285/ 285
Evaporator Coil Face Area (ft²)	14.7	14.7	14.7
Rows Deep / Fins per Inch	4 / 15	4 / 15	4 / 15
# of Wheels (D x W)	(1) 15" x 15"	(1) 15" x 15"	(1) 15" x 15"
Motor Sheave / Blower Sheave	VL40 / AK66	VL40 / AK66	VL40 / AK66
CONDENSER FAN / COIL			
Quantity of condenser Fan Motors	2	2	2
Horsepower - RPM	⅓ - 1,075	⅓ - 1,075	⅓ - 1,075
Fan Diameter / # Fan Blades	22/3	22/3	22/3
Outdoor Nominal CFM	7,200	7,200	7,200
Face Area (ft²)	35.3	35.3	35.3
Rows Deep / Fins per Inch	2/3 rows 15 fpi	2/3 rows 15 fpi	2/3 rows 15 fpi
COMPRESSOR			
Quantity / Stage	2 / Single	2 / Single	2 / Single
Type	Scroll	Scroll	Scroll
Compressor RLA / LRA ea.	22.4 / 149	10.6 / 75	7.7 / 54
ELECTRICAL DATA / STATIC			
Voltage / Phase / Frequency	208-230/3/60	460/3/60	575/3/60
Standard Max Static	1.4"	1.4"	1.4"
Outdoor Fan FLA ea.	2.4	1.2	0.9
Total Unit Amps	59	28	21.4
Min. Circuit Ampacity ¹	65	31	23
Max. Overcurrent Protection (amps) ²	80	40	30
Entrance Power Supply	Locating	Locating	Locating
Entrance Control Voltage	Dimple	Dimple	Dimple
OPERATING WEIGHT (LBS)	1365	1365	1365
SHIP WEIGHT (LBS)	1390	1390	1390

¹ Wire size should be determined in accordance with National Electrical Codes. Extensive wire runs will require larger wire sizes.

² May use fuses or HACR-type circuit breakers of the same size as noted.

Note: Always check the S&R plate for electrical data on the unit being installed.

EXPANDED COOLING DATA — 7½ TONS (A MODELS)

IDB	AIRFLOW	OUTDOOR AMBIENT TEMPERATURE																									
		65				75				85				95				105				115					
		59	63	67	71	59	63	67	71	59	63	67	71	59	63	67	71	59	63	67	71	59	63	67	71		
70	3375	MBh	88.2	91.4	100.2	-	86.1	89.3	97.8	-	84.1	87.2	95.5	-	82.0	85.0	93.2	-	77.9	80.8	88.5	-	72.2	74.8	82.0	-	
		S/T	0.73	0.61	0.42	-	0.76	0.63	0.44	-	0.78	0.65	0.45	-	0.80	0.67	0.47	-	0.83	0.70	0.48	-	0.84	0.70	0.49	-	
		ΔT	18	15	12	-	18	15	12	-	18	15	12	-	18	16	12	-	18	15	12	-	17	14	11	-	
	3000	kW	6.19	6.32	6.50	-	6.64	6.77	6.98	-	7.03	7.17	7.39	-	7.37	7.53	7.76	-	7.67	7.83	8.08	-	7.92	8.09	8.35	-	
		Amps	20.4	20.8	21.2	-	21.6	22.0	22.5	-	23.0	23.4	24.0	-	24.1	24.6	25.2	-	25.3	25.8	26.5	-	26.5	27.0	27.7	-	
		Hi pr	234	252	266	-	262	282	298	-	298	321	339	-	340	366	386	-	382	411	434	-	422	454	480	-	
	2400	Lo Pr	108	115	126	-	114	122	133	-	119	126	138	-	125	133	145	-	131	139	152	-	135	144	157	-	
		MBh	85.6	88.7	97.2	-	83.6	86.7	95.0	-	81.6	84.6	92.7	-	79.7	82.6	90.5	-	75.7	78.4	85.9	-	70.1	72.6	79.6	-	
		S/T	0.70	0.58	0.40	-	0.72	0.61	0.42	-	0.74	0.62	0.43	-	0.77	0.64	0.44	-	0.80	0.66	0.46	-	0.80	0.67	0.46	-	
	75	3375	ΔT	18	16	12	-	19	16	12	-	19	16	12	-	19	16	12	-	18	16	12	-	17	15	11	-
			kW	6.15	6.27	6.45	-	6.59	6.72	6.92	-	6.98	7.12	7.34	-	7.32	7.47	7.70	-	7.61	7.77	8.01	-	7.86	8.03	8.28	-
			Amps	20.3	20.6	21.1	-	21.4	21.8	22.4	-	22.8	23.2	23.8	-	24.0	24.4	25.0	-	25.1	25.6	26.3	-	26.3	26.8	27.5	-
3000		Hi pr	231	249	263	-	260	279	295	-	295	318	336	-	336	362	382	-	378	407	430	-	418	450	475	-	
		Lo Pr	107	114	124	-	113	120	132	-	118	125	137	-	124	132	144	-	130	138	150	-	134	143	156	-	
		MBh	79.0	81.9	89.7	-	77.2	80.0	87.7	-	75.4	78.1	85.6	-	73.5	76.2	83.5	-	69.8	72.4	79.3	-	64.7	67.1	73.5	-	
2400		S/T	0.67	0.56	0.39	-	0.70	0.58	0.40	-	0.72	0.60	0.41	-	0.74	0.62	0.43	-	0.77	0.64	0.44	-	0.77	0.65	0.45	-	
		ΔT	20	18	13	-	21	18	14	-	21	18	14	-	21	18	14	-	21	18	13	-	19	17	13	-	
		kW	6.01	6.13	6.31	-	6.44	6.57	6.76	-	6.81	6.95	7.16	-	7.15	7.29	7.52	-	7.43	7.58	7.82	-	7.67	7.83	8.08	-	
75		3375	Amps	19.9	20.2	20.7	-	21.0	21.4	21.9	-	22.3	22.7	23.3	-	23.5	23.9	24.5	-	24.6	25.1	25.7	-	25.7	26.2	26.9	-
			Hi pr	224	242	255	-	252	271	286	-	286	308	326	-	326	351	371	-	367	395	417	-	406	436	461	-
			Lo Pr	104	111	121	-	110	117	128	-	114	121	133	-	120	128	139	-	126	134	146	-	130	138	151	-
	3000	MBh	89.7	92.3	100.0	107.3	87.6	90.2	97.6	104.8	85.5	88.0	95.3	102.3	83.4	85.9	93.0	99.8	79.3	81.6	88.3	94.8	73.4	75.6	81.8	87.8	
		S/T	0.83	0.75	0.56	0.36	0.86	0.77	0.58	0.38	0.89	0.79	0.60	0.39	0.91	0.82	0.62	0.40	0.95	0.85	0.64	0.41	0.96	0.86	0.65	0.42	
		ΔT	20	19	15	11	21	19	16	11	21	19	16	11	21	19	16	11	20	19	15	11	19	18	14	10	
	2400	kW	6.24	6.36	6.55	6.75	6.69	6.82	7.03	7.25	7.08	7.23	7.45	7.69	7.43	7.59	7.83	8.07	7.73	7.89	8.14	8.40	7.99	8.16	8.42	8.69	
		Amps	20.5	20.9	21.4	22.0	21.7	22.1	22.7	23.3	23.1	23.5	24.1	24.8	24.3	24.8	25.4	26.2	25.5	26.0	26.7	27.5	26.7	27.2	27.9	28.8	
		Hi pr	236	254	268	280	265	285	301	314	301	324	342	357	343	369	390	407	386	415	439	458	427	459	485	506	
	75	3000	Lo Pr	109	116	127	135	116	123	134	143	120	128	139	149	126	134	146	156	132	141	154	163	137	145	159	169
			MBh	87.1	89.7	97.0	104.1	85.1	87.6	94.8	101.7	83.0	85.5	92.5	99.3	81.0	83.4	90.3	96.9	77.0	79.2	85.8	92.0	71.3	73.4	79.4	85.3
			S/T	0.79	0.71	0.54	0.35	0.82	0.74	0.56	0.36	0.84	0.76	0.57	0.37	0.87	0.78	0.59	0.38	0.90	0.81	0.61	0.39	0.91	0.82	0.62	0.40
2400		ΔT	21	20	16	11	21	20	16	11	21	20	16	11	22	20	16	11	21	20	16	11	20	18	15	10	
		kW	6.19	6.32	6.50	6.70	6.64	6.77	6.98	7.19	7.03	7.17	7.39	7.63	7.38	7.53	7.76	8.01	7.67	7.83	8.08	8.34	7.92	8.09	8.35	8.62	
		Amps	20.4	20.8	21.2	21.8	21.6	22.0	22.5	23.1	23.0	23.4	24.0	24.7	24.1	24.6	25.2	26.0	25.3	25.8	26.5	27.3	26.5	27.0	27.7	28.6	
75		3000	Hi pr	234	252	266	277	262	282	298	311	298	321	339	354	340	366	386	403	382	411	434	453	422	454	480	501
			Lo Pr	108	115	126	134	114	122	133	141	119	126	138	147	125	133	145	154	131	139	152	162	135	144	157	167
			MBh	80.4	82.7	89.6	96.1	78.5	80.8	87.5	93.9	76.6	78.9	85.4	91.7	74.8	77.0	83.3	89.4	71.0	73.1	79.2	85.0	65.8	67.7	73.3	78.7
		2400	S/T	0.77	0.69	0.52	0.33	0.79	0.71	0.54	0.35	0.81	0.73	0.55	0.35	0.84	0.75	0.57	0.37	0.87	0.78	0.59	0.38	0.88	0.79	0.60	0.38
			ΔT	24	22	18	12	24	22	18	12	24	22	18	12	24	22	18	13	24	22	18	12	22	20	17	12
			kW	6.06	6.18	6.36	6.55	6.49	6.62	6.82	7.02	6.87	7.01	7.22	7.45	7.20	7.35	7.58	7.82	7.49	7.65	7.88	8.13	7.73	7.90	8.15	8.41
	2400	Amps	20.0	20.3	20.8	21.4	21.2	21.5	22.0	22.7	22.5	22.9	23.5	24.1	23.6	24.1	24.7	25.4	24.8	25.3	25.9	26.7	25.9	26.4	27.1	27.9	
		Hi pr	227	244	258	269	254	274	289	302	289	311	329	343	330	355	375	391	371	399	421	439	410	441	466	486	
		Lo Pr	105	112	122	130	111	118	129	137	115	123	134	143	121	129	141	150	127	135	147	157	131	140	153	162	

IDB: Entering Indoor Dry Bulb Temperature
 High and low pressures are measured at the liquid and suction service valves.
 Shaded area reflects ACCA (TVA) conditions
 kW = Total system power
 Amps = outdoor unit amps (comp.+fan)

EXPANDED COOLING DATA — 7½ TONS (B MODELS)

IDB	AIRFLOW	OUTDOOR AMBIENT TEMPERATURE																									
		65				75				85				95				105				115					
		59	63	67	71	59	63	67	71	59	63	67	71	59	63	67	71	59	63	67	71	59	63	67	71		
70	3375	MBh	86.2	89.4	97.9	-	84.2	87.3	95.6	-	82.2	85.2	93.4	-	80.2	83.1	91.1	-	76.2	79.0	86.5	-	70.6	73.2	80.2	-	
		S/T	0.72	0.60	0.42	-	0.75	0.63	0.43	-	0.77	0.64	0.44	-	0.79	0.66	0.46	-	0.82	0.69	0.48	-	0.83	0.69	0.48	-	
		ΔT	17	15	11	-	17	15	11	-	17	15	11	-	17	15	11	-	17	15	11	-	16	14	10	-	
	3000	kW	6.27	6.39	6.56	-	6.69	6.82	7.02	-	7.07	7.21	7.42	-	7.40	7.55	7.77	-	7.68	7.83	8.07	-	7.92	8.08	8.33	-	
		Amps	21.1	21.4	21.9	-	22.2	22.6	23.1	-	23.6	24.0	24.5	-	24.7	25.1	25.7	-	25.8	26.3	26.9	-	26.9	27.4	28.1	-	
		Hi PR	234	252	266	-	262	282	298	-	298	321	339	-	340	366	386	-	382	411	434	-	422	454	480	-	
	2400	Lo PR	103	110	120	-	109	116	127	-	114	121	132	-	119	127	139	-	125	133	145	-	129	138	150	-	
		MBh	83.7	86.8	95.1	-	81.8	84.8	92.9	-	79.8	82.7	90.7	-	77.9	80.7	88.4	-	74.0	76.7	84.0	-	68.5	71.0	77.8	-	
		S/T	0.69	0.58	0.40	-	0.71	0.60	0.41	-	0.73	0.61	0.42	-	0.76	0.63	0.44	-	0.79	0.66	0.45	-	0.79	0.66	0.46	-	
	75	3375	ΔT	18	15	12	-	18	16	12	-	18	16	12	-	18	16	12	-	18	15	12	-	17	14	11	-
			kW	6.23	6.34	6.52	-	6.65	6.77	6.97	-	7.02	7.15	7.36	-	7.34	7.49	7.71	-	7.62	7.78	8.01	-	7.86	8.02	8.26	-
			Amps	21.0	21.3	21.8	-	22.1	22.5	23.0	-	23.4	23.8	24.4	-	24.5	25.0	25.6	-	25.7	26.1	26.7	-	26.8	27.2	27.9	-
3000		Hi PR	231	249	263	-	260	279	295	-	295	318	336	-	336	362	382	-	378	407	430	-	418	450	475	-	
		Lo PR	102	109	119	-	108	115	126	-	112	120	131	-	118	126	137	-	124	132	144	-	128	136	149	-	
		MBh	77.3	80.1	87.8	-	75.5	78.2	85.7	-	73.7	76.4	83.7	-	71.9	74.5	81.6	-	68.3	70.8	77.5	-	63.3	65.6	71.8	-	
2400		S/T	0.67	0.56	0.38	-	0.69	0.58	0.40	-	0.71	0.59	0.41	-	0.73	0.61	0.42	-	0.76	0.63	0.44	-	0.76	0.64	0.44	-	
		ΔT	20	17	13	-	20	17	13	-	20	17	13	-	20	17	13	-	20	17	13	-	19	16	12	-	
		kW	6.10	6.21	6.38	-	6.50	6.63	6.81	-	6.86	7.00	7.20	-	7.18	7.32	7.54	-	7.45	7.60	7.82	-	7.68	7.84	8.07	-	
75		3375	Amps	20.6	20.9	21.4	-	21.7	22.1	22.5	-	23.0	23.3	23.9	-	24.0	24.5	25.0	-	25.1	25.6	26.2	-	26.2	26.7	27.3	-
			Hi PR	224	242	255	-	252	271	286	-	286	308	326	-	326	351	371	-	367	395	417	-	406	436	461	-
			Lo PR	99	106	115	-	105	112	122	-	109	116	127	-	115	122	133	-	120	128	139	-	124	132	144	-
	3000	MBh	87.7	90.3	97.7	104.9	85.7	88.2	95.5	102.5	83.6	86.1	93.2	100.0	81.6	84.0	90.9	97.6	77.5	79.8	86.4	92.7	71.8	73.9	80.0	85.9	
		S/T	0.82	0.74	0.56	0.36	0.85	0.76	0.58	0.37	0.87	0.78	0.59	0.38	0.90	0.81	0.61	0.39	0.94	0.84	0.63	0.41	0.94	0.84	0.64	0.41	
		ΔT	20	18	15	10	20	18	15	10	20	18	15	10	20	18	15	10	20	18	15	10	18	17	14	10	
	2400	kW	6.31	6.43	6.61	6.80	6.74	6.87	7.07	7.28	7.12	7.26	7.47	7.70	7.46	7.60	7.83	8.07	7.74	7.90	8.13	8.38	7.98	8.15	8.39	8.65	
		Amps	21.2	21.6	22.1	22.6	22.4	22.8	23.3	23.9	23.7	24.1	24.7	25.3	24.9	25.3	25.9	26.6	26.0	26.5	27.1	27.9	27.1	27.6	28.3	29.1	
		Hi PR	236	254	268	280	265	285	301	314	301	324	342	357	343	369	390	407	386	415	439	458	427	459	485	506	
	75	Lo PR	104	111	121	129	110	117	128	137	115	122	133	142	121	128	140	149	126	134	147	156	131	139	152	162	
		MBh	85.1	87.7	94.9	101.8	83.2	85.6	92.7	99.5	81.2	83.6	90.5	97.1	79.2	81.5	88.3	94.7	75.2	77.5	83.9	90.0	69.7	71.8	77.7	83.4	
		S/T	0.78	0.70	0.53	0.34	0.81	0.73	0.55	0.35	0.83	0.75	0.56	0.36	0.86	0.77	0.58	0.37	0.89	0.80	0.60	0.39	0.90	0.81	0.61	0.39	
3000	ΔT	20	19	15	11	21	19	16	11	21	19	16	11	21	19	16	11	21	19	16	11	19	18	15	10		
	kW	6.27	6.39	6.57	6.75	6.69	6.82	7.02	7.22	7.07	7.21	7.42	7.64	7.40	7.55	7.77	8.01	7.68	7.84	8.07	8.32	7.92	8.08	8.33	8.59		
	Amps	21.1	21.4	21.9	22.5	22.2	22.6	23.1	23.7	23.6	24.0	24.5	25.2	24.7	25.1	25.7	26.4	25.8	26.3	26.9	27.7	26.9	27.4	28.1	28.9		
2400	Hi PR	234	252	266	277	262	282	298	311	298	321	339	354	340	366	386	403	382	411	434	453	422	454	480	501		
	Lo PR	103	110	120	128	109	116	127	135	114	121	132	141	119	127	139	148	125	133	145	155	129	138	150	160		
	MBh	78.6	80.9	87.6	94.0	76.8	79.0	85.5	91.8	74.9	77.1	83.5	89.6	73.1	75.3	81.5	87.4	69.4	71.5	77.4	83.1	64.3	66.2	71.7	76.9		
75	S/T	0.76	0.68	0.51	0.33	0.78	0.70	0.53	0.34	0.80	0.72	0.54	0.35	0.83	0.74	0.56	0.36	0.86	0.77	0.58	0.37	0.87	0.78	0.59	0.38		
	ΔT	23	21	17	12	23	21	17	12	23	21	17	12	23	21	18	12	23	21	17	12	21	20	16	11		
	kW	6.14	6.25	6.42	6.61	6.55	6.68	6.86	7.06	6.91	7.05	7.25	7.47	7.23	7.38	7.59	7.82	7.51	7.66	7.89	8.12	7.74	7.90	8.14	8.39		
75	Amps	20.7	21.1	21.5	22.1	21.8	22.2	22.7	23.3	23.1	23.5	24.0	24.7	24.2	24.6	25.2	25.9	25.3	25.8	26.4	27.1	26.4	26.9	27.5	28.3		
	Hi PR	227	244	258	269	254	274	289	302	289	311	329	343	330	355	375	391	371	399	421	439	410	441	466	486		
	Lo PR	100	107	117	124	106	113	123	131	110	117	128	136	116	123	134	143	121	129	141	150	125	133	146	155		

IDB: Entering Indoor Dry Bulb Temperature
 High and low pressures are measured at the liquid and suction service valves.
 Shaded area reflects ACCA (TVA) conditions
 kW = Total system power
 Amps = outdoor unit amps (comp.+fan)

EXPANDED COOLING DATA — 7½ TONS (B MODELS CONT.)

IDB	AIRFLOW	OUTDOOR AMBIENT TEMPERATURE																											
		65				75				85				95				105				115							
		59	63	67	71	59	63	67	71	59	63	67	71	59	63	67	71	59	63	67	71	59	63	67	71				
80	MBh	89.3	91.2	97.4	104.2	87.2	89.1	95.2	101.7	85.1	87.0	92.9	99.3	83.0	84.8	90.6	96.9	81.0	82.8	88.6	95.0	78.9	80.6	86.1	92.0	73.1	74.7	79.8	85.3
	S/T	0.90	0.85	0.69	0.51	0.93	0.88	0.71	0.53	0.96	0.90	0.73	0.55	1.00	0.93	0.75	0.56	1.00	0.93	0.75	0.56	1.00	0.96	0.78	0.59	1.00	0.97	0.79	0.59
	ΔT	22	21	18	15	22	21	19	15	23	21	19	15	23	21	19	15	23	21	19	15	21	18	15	12	20	20	17	14
	kW	6.36	6.48	6.66	6.85	6.79	6.92	7.12	7.33	7.17	7.32	7.53	7.76	7.51	7.66	7.89	8.13	7.80	7.96	8.20	8.45	8.05	8.21	8.46	8.72	8.05	8.21	8.46	8.72
	Amps	21.4	21.7	22.2	22.8	22.5	22.9	23.4	24.0	23.9	24.3	24.8	25.5	25.0	25.5	26.1	26.8	26.2	26.6	27.3	28.1	27.3	27.8	28.5	29.3	27.3	27.8	28.5	29.3
	Hi PR	238	257	271	283	268	288	304	317	304	328	346	361	347	373	394	411	390	420	443	462	431	464	490	511	431	464	490	511
	Lo PR	106	112	123	131	112	119	130	138	116	123	135	143	122	130	141	151	128	136	148	158	132	140	153	163	132	140	153	163
	MBh	86.7	88.5	94.6	101.1	84.6	86.5	92.4	98.8	82.6	84.4	90.2	96.4	80.6	82.4	88.0	94.1	76.6	78.2	83.6	89.4	70.9	72.5	77.4	82.8	70.9	72.5	77.4	82.8
	S/T	0.86	0.81	0.66	0.49	0.89	0.84	0.68	0.51	0.91	0.86	0.70	0.52	0.94	0.88	0.72	0.54	0.98	0.92	0.75	0.56	0.99	0.93	0.75	0.56	0.99	0.93	0.75	0.56
	ΔT	23	22	19	15	23	22	19	15	23	22	19	15	23	22	19	16	23	22	19	15	21	21	18	14	21	21	18	14
kW	6.31	6.43	6.61	6.80	6.74	6.87	7.07	7.28	7.12	7.26	7.47	7.70	7.46	7.60	7.83	8.07	7.74	7.90	8.13	8.38	7.98	8.15	8.39	8.65	7.98	8.15	8.39	8.65	
Amps	21.2	21.6	22.1	22.6	22.4	22.8	23.3	23.9	23.7	24.1	24.7	25.3	24.9	25.3	25.9	26.6	26.0	26.5	27.1	27.9	27.1	27.6	28.3	29.1	27.1	27.6	28.3	29.1	
Hi PR	236	254	268	280	265	285	301	314	301	324	342	357	343	369	390	407	386	415	439	458	427	459	485	506	427	459	485	506	
Lo PR	105	111	121	129	110	117	128	137	115	122	133	142	121	128	140	149	126	134	147	156	131	139	152	162	131	139	152	162	
MBh	80.0	81.7	87.3	93.3	78.1	79.8	85.3	91.2	76.3	77.9	83.3	89.0	74.4	76.0	81.2	86.8	70.7	72.2	77.2	82.5	65.5	66.9	71.5	76.4	65.5	66.9	71.5	76.4	
S/T	0.83	0.78	0.63	0.47	0.86	0.81	0.66	0.49	0.88	0.83	0.67	0.50	0.91	0.85	0.69	0.52	0.94	0.89	0.72	0.54	0.95	0.89	0.73	0.54	0.95	0.89	0.73	0.54	
ΔT	25	24	21	17	26	25	21	17	26	25	21	17	26	25	22	17	26	24	21	17	24	23	20	16	24	23	20	16	
kW	6.18	6.30	6.47	6.65	6.60	6.72	6.91	7.12	6.96	7.10	7.31	7.52	7.29	7.43	7.65	7.88	7.56	7.72	7.95	8.19	7.80	7.96	8.20	8.45	7.80	7.96	8.20	8.45	
Amps	20.9	21.2	21.6	22.2	22.0	22.3	22.8	23.4	23.3	23.6	24.2	24.8	24.4	24.8	25.4	26.1	25.5	25.9	26.6	27.3	26.6	27.1	27.7	28.5	26.6	27.1	27.7	28.5	
Hi PR	229	246	260	271	257	277	292	305	292	315	332	346	333	358	378	395	375	403	426	444	414	445	470	490	414	445	470	490	
Lo PR	101	108	118	125	107	114	124	132	111	118	129	138	117	124	136	145	123	130	142	152	127	135	147	157	127	135	147	157	

85	MBh	90.8	92.6	97.0	103.4	88.7	90.4	94.7	101.0	86.6	88.3	92.4	98.6	84.5	86.1	90.2	96.2	80.3	81.8	85.7	91.4	74.3	75.8	79.4	84.7
	S/T	0.95	0.91	0.82	0.67	0.98	0.95	0.85	0.69	1.00	0.97	0.87	0.71	1.00	1.00	0.90	0.73	1.00	1.00	0.94	0.76	1.00	1.00	0.94	0.77
	ΔT	23	23	22	19	24	23	22	19	24	23	22	19	23	23	22	19	22	22	22	19	20	21	20	18
	kW	6.40	6.52	6.71	6.90	6.84	6.97	7.17	7.39	7.23	7.37	7.59	7.81	7.57	7.72	7.95	8.19	7.86	8.02	8.26	8.51	8.11	8.27	8.53	8.79
	Amps	21.5	21.8	22.3	22.9	22.7	23.0	23.6	24.2	24.0	24.4	25.0	25.7	25.2	25.6	26.2	27.0	26.4	26.8	27.5	28.3	27.5	28.0	28.7	29.5
	Hi PR	241	259	274	285	270	291	307	320	307	331	349	364	350	377	398	415	394	424	448	467	435	468	495	516
	Lo PR	107	113	124	132	113	120	131	139	117	125	136	145	123	131	143	152	129	137	150	159	133	142	155	165
	MBh	88.2	89.9	94.1	100.4	86.1	87.8	91.9	98.1	84.1	85.7	89.7	95.7	82.0	83.6	87.6	93.4	77.9	79.4	83.2	88.7	72.2	73.6	77.1	82.2
	S/T	0.90	0.87	0.79	0.64	0.93	0.90	0.81	0.66	0.96	0.92	0.83	0.68	0.99	0.95	0.86	0.70	1.00	0.99	0.89	0.73	1.00	1.00	0.90	0.73
	ΔT	24	24	23	20	25	24	23	20	25	24	23	20	25	24	23	20	24	24	23	20	22	23	21	18
kW	6.36	6.48	6.66	6.85	6.79	6.92	7.12	7.33	7.17	7.32	7.53	7.76	7.51	7.66	7.89	8.13	7.80	7.96	8.20	8.45	8.05	8.21	8.46	8.72	
Amps	21.4	21.7	22.2	22.8	22.5	22.9	23.4	24.0	23.9	24.3	24.8	25.5	25.0	25.5	26.1	26.8	26.2	26.6	27.3	28.1	27.3	27.8	28.5	29.3	
Hi PR	238	257	271	283	268	288	304	317	304	328	346	361	347	373	394	411	390	420	443	462	431	464	490	511	
Lo PR	106	112	123	131	112	119	130	138	116	123	135	143	122	130	141	151	128	136	148	158	132	140	153	163	
MBh	81.4	83.0	86.9	92.7	79.5	81.0	84.9	90.5	77.6	79.1	82.8	88.4	75.7	77.2	80.8	86.2	71.9	73.3	76.8	81.9	66.6	67.9	71.1	75.9	
S/T	0.87	0.84	0.76	0.61	0.90	0.87	0.78	0.64	0.92	0.89	0.80	0.65	0.95	0.92	0.83	0.67	0.99	0.95	0.86	0.70	1.00	0.96	0.87	0.71	
ΔT	27	27	25	22	27	27	25	22	27	27	26	22	28	27	26	22	27	27	25	22	25	25	24	20	
kW	6.22	6.34	6.52	6.70	6.64	6.77	6.96	7.17	7.02	7.15	7.36	7.58	7.34	7.49	7.71	7.94	7.62	7.77	8.01	8.25	7.86	8.02	8.26	8.52	
Amps	21.0	21.3	21.8	22.3	22.1	22.5	23.0	23.6	23.4	23.8	24.4	25.0	24.5	25.0	25.5	26.2	25.6	26.1	26.7	27.5	26.8	27.2	27.9	28.7	
Hi PR	231	249	263	274	260	279	295	308	295	318	335	350	336	362	382	399	378	407	430	448	418	450	475	495	
Lo PR	102	109	119	127	108	115	126	134	112	120	131	139	118	126	137	146	124	132	144	153	128	136	149	158	

IDB: Entering Indoor Dry Bulb Temperature
 High and low pressures are measured at the liquid and suction service valves.
 Shaded area reflects AHRI (TVA) conditions
 kW = Total system power
 Amps = outdoor unit amps (comp.+fan)

EXPANDED COOLING DATA — 8½ TONS

IDB		OUTDOOR AMBIENT TEMPERATURE																																			
		65						75						85						95						105						115					
		59	63	67	71	59	63	67	71	59	63	67	71	59	63	67	71	59	63	67	71	59	63	67	71	59	63	67	71								
		ENTERING INDOOR WET BULB TEMPERATURE																																			
		MBh	100.0	103.6	113.5	-	97.6	101.2	110.9	-	95.3	98.8	108.2	-	93.0	96.4	105.6	-	88.3	91.6	100.3	-	81.8	84.8	92.9	-											
		S/T	0.69	0.58	0.40	-	0.72	0.60	0.42	-	0.74	0.62	0.43	-	0.76	0.64	0.44	-	0.79	0.66	0.46	-	0.80	0.67	0.46	-											
3600		ΔT	18	15	12	-	18	16	12	-	18	16	12	-	18	16	12	-	18	15	12	-	17	14	11	-											
		kW	8.90	8.90	8.90	-	8.90	8.90	8.90	-	8.90	8.90	8.90	-	8.90	8.90	8.90	-	8.90	8.90	8.90	-	8.90	8.90	8.90	-											
		HI PR	245	263	278	-	274	295	312	-	312	336	355	-	355	382	404	-	400	430	454	-	442	475	502	-											
		LO PR	104	110	120	-	109	116	127	-	114	121	132	-	119	127	139	-	125	133	145	-	130	138	150	-											
		MBh	97.0	100.6	110.2	-	94.8	98.2	107.6	-	92.5	95.9	105.1	-	90.3	93.6	102.5	-	85.8	88.9	97.4	-	79.4	82.3	90.2	-											
		S/T	0.66	0.55	0.38	-	0.69	0.57	0.40	-	0.70	0.59	0.41	-	0.73	0.61	0.42	-	0.75	0.63	0.44	-	0.76	0.63	0.44	-											
		ΔT	18	16	12	-	19	16	12	-	19	16	12	-	19	16	12	-	19	16	12	-	17	15	11	-											
3200		kW	8.90	8.90	8.90	-	8.90	8.90	8.90	-	8.90	8.90	8.90	-	8.90	8.90	8.90	-	8.90	8.90	8.90	-	8.90	8.90	8.90	-											
		HI PR	242	261	275	-	272	292	309	-	309	332	351	-	352	379	400	-	396	426	450	-	437	471	497	-											
		LO PR	103	109	119	-	108	115	126	-	113	120	131	-	118	126	137	-	124	132	144	-	128	136	149	-											
		MBh	89.6	92.8	101.7	-	87.5	90.7	99.3	-	85.4	88.5	97.0	-	83.3	86.4	94.6	-	79.2	82.0	89.9	-	73.3	76.0	83.3	-											
		S/T	0.64	0.53	0.37	-	0.66	0.55	0.38	-	0.68	0.57	0.39	-	0.70	0.58	0.41	-	0.73	0.61	0.42	-	0.73	0.61	0.42	-											
		ΔT	19	16	12	-	19	16	12	-	19	16	12	-	19	17	13	-	19	16	12	-	18	15	12	-											
2800		kW	8.90	8.90	8.90	-	8.90	8.90	8.90	-	8.90	8.90	8.90	-	8.90	8.90	8.90	-	8.90	8.90	8.90	-	8.90	8.90	8.90	-											
		HI PR	235	253	267	-	264	284	299	-	300	323	341	-	341	367	388	-	384	413	436	-	424	457	482	-											
		LO PR	99	106	116	-	105	112	122	-	109	116	127	-	115	122	133	-	120	128	140	-	124	132	144	-											

		MBh	101.6	104.7	113.3	121.6	99.3	102.2	110.6	118.8	96.9	99.8	108.0	115.9	94.6	97.4	105.4	113.1	89.8	92.5	100.1	107.4	83.2	85.7	92.7	99.5
		S/T	0.79	0.71	0.53	0.34	0.82	0.73	0.55	0.36	0.84	0.75	0.57	0.37	0.87	0.77	0.59	0.38	0.90	0.80	0.61	0.39	0.91	0.81	0.61	0.39
		ΔT	20	19	15	11	21	19	16	11	21	19	16	11	21	19	16	11	21	19	16	11	19	18	15	10
3600		kW	8.90	8.90	8.90	8.90	8.90	8.90	8.90	8.90	8.90	8.90	8.90	8.90	8.90	8.90	8.90	8.90	8.90	8.90	8.90	8.90	8.90	8.90	8.90	8.90
		HI PR	247	266	281	293	277	298	315	329	315	339	358	374	359	386	408	426	404	435	459	479	446	480	507	529
		LO PR	105	111	122	129	111	118	128	137	115	122	133	142	121	128	140	149	126	135	147	156	131	139	152	162
		MBh	98.7	101.6	110.0	118.0	96.4	99.2	107.4	115.3	94.1	96.9	104.9	112.5	91.8	94.5	102.3	109.8	87.2	89.8	97.2	104.3	80.8	83.2	90.0	96.6
		S/T	0.75	0.67	0.51	0.33	0.78	0.70	0.53	0.34	0.80	0.72	0.54	0.35	0.83	0.74	0.56	0.36	0.86	0.77	0.58	0.37	0.86	0.77	0.58	0.38
		ΔT	21	20	16	11	22	20	16	11	22	20	16	11	22	20	16	11	21	20	16	11	20	18	15	10
3200		kW	8.90	8.90	8.90	8.90	8.90	8.90	8.90	8.90	8.90	8.90	8.90	8.90	8.90	8.90	8.90	8.90	8.90	8.90	8.90	8.90	8.90	8.90	8.90	8.90
		HI PR	245	263	278	290	274	295	312	325	312	336	355	370	355	383	404	421	400	430	454	474	442	476	502	524
		LO PR	104	110	120	128	109	116	127	135	114	121	132	141	120	127	139	148	125	133	145	155	130	138	150	160
		MBh	91.1	93.8	101.5	108.9	89.0	91.6	99.1	106.4	86.8	89.4	96.8	103.9	84.7	87.2	94.4	101.3	80.5	82.9	89.7	96.3	74.6	76.8	83.1	89.2
		S/T	0.73	0.65	0.49	0.32	0.75	0.67	0.51	0.33	0.77	0.69	0.52	0.34	0.80	0.71	0.54	0.35	0.83	0.74	0.56	0.36	0.83	0.74	0.56	0.36
		ΔT	22	20	16	11	22	20	17	11	22	20	17	11	22	20	17	12	22	20	16	11	20	19	15	11
2800		kW	8.90	8.90	8.90	8.90	8.90	8.90	8.90	8.90	8.90	8.90	8.90	8.90	8.90	8.90	8.90	8.90	8.90	8.90	8.90	8.90	8.90	8.90	8.90	8.90
		HI PR	237	255	270	281	266	286	303	316	303	326	344	359	345	371	392	409	388	417	441	460	429	461	487	508
		LO PR	101	107	117	124	106	113	123	131	110	117	128	137	116	123	135	143	121	129	141	150	126	134	146	155

IDB: Entering Indoor Dry Bulb Temperature
 High and low pressures are measured at the liquid and suction service valves.
 Shaded area reflects ACCA (TVA) conditions
 kW = Total system power
 Amps = outdoor unit amps (comp.+fan)

EXPANDED COOLING DATA — 10 TONS

IDB		OUTDOOR AMBIENT TEMPERATURE																																			
		65						75						85						95						105						115					
		59	63	67	71	59	63	67	71	59	63	67	71	59	63	67	71	59	63	67	71	59	63	67	71	59	63	67	71								
		ENTERING INDOOR WET BULB TEMPERATURE																																			
AIRFLOW		59	63	67	71	59	63	67	71	59	63	67	71	59	63	67	71	59	63	67	71	59	63	67	71	59	63	67	71								
70	4500	MBh	115.6	119.8	131.3	-	112.9	117.1	128.3	-	110.3	114.3	125.2	-	107.6	111.5	122.1	-	102.2	105.9	116.0	-	94.7	98.1	107.5	-	85	89	98	107							
		S/T	0.74	0.62	0.43	-	0.77	0.64	0.45	-	0.79	0.66	0.46	-	0.82	0.68	0.47	-	0.85	0.71	0.49	-	0.85	0.71	0.49	-	0.85	0.71	0.49	-							
		ΔT	18	15	12	-	18	15	12	-	18	15	12	-	18	16	12	-	18	15	12	-	17	14	11	-	17	14	11	-							
		Hi Pr	247	265	280	-	277	298	314	-	315	339	358	-	358	386	407	-	403	434	458	-	446	479	506	-	446	479	506	-							
		Lo Pr	106	113	124	-	112	120	131	-	117	124	136	-	123	131	143	-	129	137	149	-	133	142	155	-	133	142	155	-							
		MBh	112.3	116.4	127.5	-	109.7	113.7	124.5	-	107.0	110.9	121.6	-	104.4	108.2	118.6	-	99.2	102.8	112.7	-	91.9	95.3	104.4	-	81	85	94	103							
		S/T	0.71	0.59	0.41	-	0.73	0.61	0.43	-	0.75	0.63	0.44	-	0.78	0.65	0.45	-	0.81	0.67	0.47	-	0.81	0.68	0.47	-	0.81	0.68	0.47	-							
		ΔT	18	16	12	-	19	16	12	-	19	16	12	-	19	16	12	-	18	16	12	-	17	15	11	-	17	15	11	-							
		Hi Pr	244	263	277	-	274	295	311	-	312	335	354	-	355	382	403	-	399	430	454	-	441	475	501	-	441	475	501	-							
		Lo Pr	105	112	122	-	111	118	129	-	116	123	134	-	122	129	141	-	127	135	148	-	132	140	153	-	132	140	153	-							
3200	4500	MBh	103.6	107.4	117.7	-	101.2	104.9	114.9	-	98.8	102.4	112.2	-	96.4	99.9	109.5	-	91.6	94.9	104.0	-	84.8	87.9	96.3	-	74	78	87	96							
		S/T	0.68	0.57	0.40	-	0.71	0.59	0.41	-	0.73	0.61	0.42	-	0.75	0.63	0.43	-	0.78	0.65	0.45	-	0.78	0.66	0.45	-	0.78	0.66	0.45	-							
		ΔT	20	18	13	-	21	18	14	-	21	18	14	-	21	18	14	-	20	18	13	-	19	17	13	-	19	17	13	-							
		Hi Pr	237	255	269	-	266	286	302	-	302	325	343	-	344	370	391	-	387	417	440	-	428	460	486	-	428	460	486	-							
		Lo Pr	102	109	119	-	108	115	125	-	112	119	130	-	118	125	137	-	124	131	143	-	128	136	148	-	128	136	148	-							

75	4500	MBh	117.6	121.1	131.0	140.6	114.9	118.3	128.0	137.4	112.1	115.4	125.0	134.1	109.4	112.6	121.9	130.8	103.9	107.0	115.8	124.3	96.3	99.1	107.3	115.1
		S/T	0.84	0.76	0.57	0.37	0.88	0.78	0.59	0.38	0.90	0.80	0.61	0.39	0.93	0.83	0.63	0.40	0.96	0.86	0.65	0.42	0.97	0.87	0.66	0.42
		ΔT	20	19	15	11	21	19	16	11	21	19	16	11	21	19	16	11	20	19	15	11	19	18	14	10
		Hi Pr	249	268	283	295	280	301	318	331	318	342	361	377	362	390	411	429	407	438	463	483	450	484	511	533
		Lo Pr	107	114	125	133	114	121	132	140	118	126	137	146	124	132	144	153	130	138	151	161	134	143	156	166
		MBh	114.2	117.5	127.2	136.6	111.5	114.8	124.3	133.4	108.9	112.1	121.3	130.2	106.2	109.3	118.4	127.0	100.9	103.9	112.4	120.7	93.5	96.2	104.2	111.8
		S/T	0.81	0.72	0.55	0.35	0.84	0.75	0.57	0.36	0.86	0.77	0.58	0.37	0.88	0.79	0.60	0.38	0.92	0.82	0.62	0.40	0.93	0.83	0.63	0.40
		ΔT	21	19	16	11	21	20	16	11	21	20	16	11	22	20	16	11	21	20	16	11	20	18	15	10
		Hi Pr	247	265	280	292	277	298	315	328	315	339	358	373	358	386	407	425	403	434	458	478	446	480	506	528
		Lo Pr	106	113	124	132	112	120	131	139	117	124	136	145	123	131	143	152	129	137	149	159	133	142	155	165
3200	4500	MBh	105.4	108.5	117.4	126.0	102.9	106.0	114.7	123.1	100.5	103.4	112.0	120.2	98.0	100.9	109.2	117.2	93.1	95.9	103.8	111.4	86.3	88.8	96.1	103.2
		S/T	0.78	0.69	0.53	0.34	0.81	0.72	0.55	0.35	0.83	0.74	0.56	0.36	0.85	0.76	0.58	0.37	0.88	0.79	0.60	0.39	0.89	0.80	0.60	0.39
		ΔT	24	22	18	12	24	22	18	12	24	22	18	12	24	22	18	13	24	22	18	12	22	20	17	12
		Hi Pr	239	257	272	284	268	289	305	318	305	329	347	362	348	374	395	412	391	421	445	464	432	465	491	512
		Lo Pr	103	110	120	128	109	116	127	135	113	121	132	140	119	127	138	147	125	133	145	154	129	137	150	160

IDB: Entering Indoor Dry Bulb Temperature
 High and low pressures are measured at the liquid and suction service valves.
 Shaded area reflects ACCA (TVA) conditions
 kW = Total system power
 Amps = outdoor unit amps (comp. + fan)

EXPANDED COOLING DATA — 10 TONS (CONT.)

IDB		OUTDOOR AMBIENT TEMPERATURE																																			
		65						75						85						95						105						115					
		AIRFLOW				ENTERING INDOOR WET BULB TEMPERATURE				ENTERING INDOOR WET BULB TEMPERATURE				ENTERING INDOOR WET BULB TEMPERATURE				ENTERING INDOOR WET BULB TEMPERATURE				ENTERING INDOOR WET BULB TEMPERATURE				ENTERING INDOOR WET BULB TEMPERATURE											
	59	63	67	71	59	63	67	71	59	63	67	71	59	63	67	71	59	63	67	71	59	63	67	71	59	63	67	71									
80	4500	MBh	119.7	122.3	130.7	139.7	116.9	119.4	127.6	136.4	114.1	116.6	124.6	133.2	111.3	113.8	121.5	129.9	105.8	108.1	115.5	123.4	98.0	100.1	107.0	114.3											
		S/T	0.93	0.87	0.71	0.53	0.96	0.90	0.73	0.55	1.00	0.92	0.75	0.56	1.00	0.95	0.78	0.58	1.00	1.00	0.81	0.60	1.00	1.00	0.81	0.60											
		ΔT	23	22	19	15	23	22	19	15	23	22	19	15	23	22	19	15	22	22	19	15	20	20	18	14											
	4000	Hi Pr	252	271	286	298	282	304	321	335	321	346	365	381	366	394	416	433	411	443	468	488	455	489	517	539											
		Lo Pr	109	116	126	134	115	122	133	142	119	127	138	147	125	133	145	155	131	140	152	162	136	144	158	168											
		MBh	116.2	118.7	126.9	135.6	113.5	116.0	123.9	132.4	110.8	113.2	121.0	129.3	108.1	110.4	118.0	126.1	102.7	104.9	112.1	119.8	95.1	97.2	103.8	111.0											
	3200	S/T	0.88	0.83	0.67	0.50	0.92	0.86	0.70	0.52	0.94	0.88	0.72	0.54	0.97	0.91	0.74	0.55	1.00	0.94	0.77	0.57	1.00	0.95	0.77	0.58											
		ΔT	24	23	20	16	24	23	20	16	24	23	20	16	24	23	20	16	24	23	20	16	22	21	18	15											
		Hi Pr	249	268	283	295	280	301	318	331	318	342	361	377	362	390	412	429	407	438	463	483	450	484	511	533											
	85	4500	Lo Pr	107	114	125	133	114	121	132	140	118	126	137	146	124	132	144	153	130	138	151	161	134	143	156	166										
			MBh	107.2	109.6	117.1	125.2	104.8	107.0	114.4	122.3	102.3	104.5	111.6	119.3	99.8	101.9	108.9	116.4	94.8	96.8	103.5	110.6	87.8	89.7	95.8	102.5										
			S/T	0.85	0.80	0.65	0.49	0.88	0.83	0.67	0.50	0.91	0.85	0.69	0.52	0.93	0.88	0.71	0.53	0.97	0.91	0.74	0.55	0.98	0.92	0.75	0.56										
3200		ΔT	26	25	22	17	27	25	22	18	27	25	22	18	27	26	22	18	26	25	22	18	25	24	21	16											
		Hi Pr	242	260	275	286	271	292	308	321	308	332	350	366	351	378	399	416	395	425	449	468	437	470	496	517											
		Lo Pr	104	111	121	129	110	117	128	136	114	122	133	142	120	128	140	149	126	134	146	156	130	139	151	161											

85	4500	MBh	121.8	124.1	130.0	138.7	118.9	121.2	127.0	135.5	116.1	118.4	124.0	132.2	113.3	115.5	120.9	129.0	107.6	109.7	114.9	122.6	99.7	101.6	106.4	113.5					
		S/T	0.97	0.94	0.85	0.69	1.00	0.97	0.88	0.71	1.00	1.00	0.90	0.73	1.00	1.00	0.93	0.75	1.00	1.00	0.96	0.78	1.00	1.00	0.97	0.79					
		ΔT	24	24	22	19	24	24	23	20	24	24	23	20	23	24	23	20	22	22	23	20	20	21	21	18					
	4000	Hi Pr	254	273	289	301	285	307	324	338	324	349	369	384	369	398	420	438	416	447	472	493	459	494	522	544					
		Lo Pr	110	117	127	136	116	123	135	143	120	128	140	149	126	135	147	156	133	141	154	164	137	146	159	170					
		MBh	118.2	120.5	126.2	134.7	115.5	117.7	123.3	131.5	112.7	114.9	120.3	128.4	110.0	112.1	117.4	125.3	104.5	106.5	111.5	119.0	96.8	98.7	103.3	110.2					
	3200	S/T	0.93	0.89	0.81	0.65	0.96	0.93	0.84	0.68	0.98	0.95	0.86	0.70	1.00	0.98	0.89	0.72	1.00	1.00	0.92	0.75	1.00	1.00	0.93	0.75					
		ΔT	25	25	23	20	25	25	24	21	26	25	24	21	25	25	24	21	24	24	24	20	22	23	22	19					
		Hi Pr	252	271	286	298	282	304	321	335	321	346	365	381	366	394	416	433	411	443	468	488	455	489	517	539					
	85	4500	Lo Pr	109	116	126	134	115	122	133	142	119	127	138	147	125	133	145	155	131	140	152	162	136	144	158	168				
			MBh	109.1	111.2	116.5	124.3	106.6	108.6	113.8	121.4	104.0	106.1	111.1	118.5	101.5	103.5	108.4	115.6	96.4	98.3	103.0	109.8	89.3	91.1	95.4	101.7				
			S/T	0.89	0.86	0.78	0.63	0.93	0.89	0.81	0.65	0.95	0.92	0.83	0.67	0.98	0.95	0.85	0.69	1.00	0.98	0.89	0.72	1.00	0.99	0.89	0.72				
3200		ΔT	28	28	26	23	28	28	26	23	28	28	26	23	29	28	27	23	28	28	26	23	26	26	24	21					
		Hi Pr	244	263	277	289	274	295	311	325	311	335	354	369	355	382	403	420	399	430	454	473	441	475	501	523					
		Lo Pr	105	112	122	130	111	118	129	138	116	123	134	143	121	129	141	150	127	135	148	157	132	140	153	163					

IDB: Entering Indoor Dry Bulb Temperature
 High and low pressures are measured at the liquid and suction service valves.
 Shaded area reflects AHRI (TVA) conditions
 kW = Total system power
 Amps = outdoor unit amps (comp.+fan)

EXPANDED COOLING DATA — 12½ TONS

IDB	AIRFLOW	OUTDOOR AMBIENT TEMPERATURE																									
		65				75				85				95				105				115					
		59	63	67	71	59	63	67	71	59	63	67	71	59	63	67	71	59	63	67	71	59	63	67	71		
70	4725	MBh	143.1	148.3	162.5	-	139.7	144.8	158.7	-	136.4	141.4	154.9	-	133.1	137.9	151.1	-	126.4	131.0	143.6	-	117.1	121.4	133.0	-	
		S/T	0.70	0.59	0.41	-	0.73	0.61	0.42	-	0.75	0.62	0.43	-	0.77	0.64	0.45	-	0.80	0.67	0.46	-	0.81	0.67	0.47	-	
	4200	ΔT	20	17	13	-	20	17	13	-	20	17	13	-	20	17	13	-	20	17	13	-	18	16	12	-	
		kW	10.42	10.64	10.97	-	11.21	11.45	11.82	-	11.92	12.18	12.57	-	12.54	12.82	13.24	-	13.07	13.36	13.80	-	13.52	13.83	14.29	-	
	3360	Amps	36.3	36.9	37.9	-	38.5	39.3	40.3	-	41.2	42.0	43.1	-	43.4	44.3	45.5	-	45.7	46.6	47.9	-	47.9	48.9	50.3	-	
		Hi PR	247	266	281	-	277	298	315	-	315	339	358	-	359	386	408	-	404	434	459	-	446	480	507	-	
	75	4725	Lo PR	100	107	117	-	106	113	123	-	110	117	128	-	116	123	135	-	121	129	141	-	126	134	146	-
			MBh	138.9	144.0	157.7	-	135.7	140.6	154.1	-	132.4	137.3	150.4	-	129.2	133.9	146.7	-	122.7	127.2	139.4	-	113.7	117.9	129.1	-
		4200	S/T	0.67	0.56	0.39	-	0.69	0.58	0.40	-	0.71	0.60	0.41	-	0.74	0.61	0.43	-	0.76	0.64	0.44	-	0.77	0.64	0.45	-
			ΔT	20	18	13	-	21	18	14	-	21	18	14	-	21	18	14	-	21	18	13	-	19	17	13	-
3360		kW	10.33	10.55	10.88	-	11.12	11.36	11.73	-	11.82	12.08	12.47	-	12.44	12.71	13.13	-	12.96	13.25	13.68	-	13.41	13.71	14.17	-	
		Amps	36.0	36.7	37.6	-	38.3	39.0	40.0	-	40.9	41.7	42.8	-	43.1	44.0	45.2	-	45.4	46.3	47.5	-	47.6	48.5	49.9	-	
75		4725	Hi PR	244	263	278	-	274	295	312	-	312	336	355	-	355	382	404	-	400	430	454	-	442	475	502	-
			Lo PR	99	106	116	-	105	112	122	-	109	116	127	-	115	122	133	-	120	128	140	-	124	132	144	-
		4200	MBh	128.2	132.9	145.6	-	125.2	129.8	142.2	-	122.2	126.7	138.8	-	119.3	123.6	135.4	-	113.3	117.4	128.7	-	104.9	108.8	119.2	-
			S/T	0.65	0.54	0.37	-	0.67	0.56	0.39	-	0.69	0.57	0.40	-	0.71	0.59	0.41	-	0.74	0.61	0.43	-	0.74	0.62	0.43	-
	3360	ΔT	23	20	15	-	23	20	15	-	23	20	15	-	23	20	15	-	23	20	15	-	21	18	14	-	
		kW	10.09	10.30	10.62	-	10.86	11.09	11.44	-	11.53	11.78	12.16	-	12.13	12.39	12.80	-	12.64	12.92	13.34	-	13.07	13.37	13.81	-	
	75	4725	Amps	35.3	35.9	36.8	-	37.4	38.2	39.1	-	40.0	40.7	41.8	-	42.1	43.0	44.1	-	44.3	45.2	46.4	-	46.5	47.4	48.7	-
			Hi PR	237	255	269	-	266	286	302	-	303	326	344	-	345	371	392	-	388	417	441	-	428	461	487	-
		4200	Lo PR	97	103	112	-	102	108	118	-	106	113	123	-	111	118	129	-	117	124	135	-	121	128	140	-
			MBh	145.5	149.8	162.1	174.0	142.1	146.3	158.4	170.0	138.7	142.8	154.6	165.9	135.3	139.3	150.8	161.9	128.6	132.4	143.3	153.8	119.1	122.6	132.7	142.5
3360		S/T	0.80	0.71	0.54	0.35	0.83	0.74	0.56	0.36	0.85	0.76	0.57	0.37	0.88	0.78	0.59	0.38	0.91	0.81	0.62	0.40	0.92	0.82	0.62	0.40	
		ΔT	23	21	17	12	23	21	17	12	23	21	17	12	23	21	17	12	23	21	17	12	21	20	16	11	
75		4725	kW	10.50	10.72	11.06	11.41	11.31	11.55	11.92	12.31	12.02	12.28	12.68	13.10	12.65	12.92	13.35	13.80	13.18	13.47	13.92	14.39	13.64	13.95	14.41	14.90
			Amps	36.5	37.2	38.2	39.3	38.8	39.6	40.6	41.8	41.5	42.3	43.4	44.7	43.8	44.6	45.8	47.3	46.0	47.0	48.3	49.8	48.3	49.3	50.7	52.3
		4200	Hi PR	249	268	283	296	280	301	318	332	318	343	362	377	363	390	412	430	408	439	463	483	451	485	512	534
			Lo PR	102	108	118	126	107	114	125	133	111	119	129	138	117	125	136	145	123	131	143	152	127	135	147	157
	3360	MBh	141.3	145.4	157.4	169.0	138.0	142.1	153.8	165.0	134.7	138.7	150.1	161.1	131.4	135.3	146.4	157.2	124.8	128.5	139.1	149.3	115.6	119.1	128.9	138.3	
		S/T	0.76	0.68	0.52	0.33	0.79	0.71	0.53	0.34	0.81	0.72	0.55	0.35	0.84	0.75	0.57	0.36	0.87	0.78	0.59	0.38	0.88	0.78	0.59	0.38	
	75	4725	ΔT	24	22	18	12	24	22	18	12	24	22	18	12	24	22	18	13	24	22	18	12	22	20	17	12
			kW	10.42	10.64	10.97	11.32	11.22	11.46	11.82	12.21	11.92	12.18	12.57	12.99	12.54	12.82	13.24	13.68	13.07	13.36	13.80	14.27	13.53	13.83	14.29	14.77
		4200	Amps	36.3	36.9	37.9	39.0	38.5	39.3	40.3	41.5	41.2	42.0	43.1	44.4	43.4	44.3	45.5	46.9	45.7	46.6	47.9	49.4	47.9	48.9	50.3	51.9
			Hi PR	247	266	281	293	277	298	315	328	315	339	358	374	359	386	408	425	404	435	459	479	446	480	507	529
3360		Lo PR	101	107	117	124	106	113	123	131	110	117	128	137	116	123	135	143	121	129	141	150	126	134	146	155	
		MBh	130.4	134.2	145.3	155.9	127.3	131.1	141.9	152.3	124.3	128.0	138.5	148.7	121.3	124.9	135.2	145.1	115.2	118.6	128.4	137.8	106.7	109.9	118.9	127.7	
75		4725	S/T	0.73	0.66	0.50	0.32	0.76	0.68	0.52	0.33	0.78	0.70	0.53	0.34	0.81	0.72	0.55	0.35	0.84	0.75	0.57	0.36	0.84	0.75	0.57	0.36
			ΔT	26	24	20	14	27	24	20	14	27	24	20	14	27	25	20	14	26	24	20	14	25	23	19	13
		4200	kW	10.17	10.38	10.71	11.05	10.94	11.18	11.53	11.91	11.63	11.88	12.26	12.67	12.23	12.50	12.91	13.34	12.74	13.03	13.45	13.90	13.19	13.48	13.93	14.40
			Amps	35.5	36.2	37.1	38.1	37.7	38.4	39.4	40.6	40.3	41.0	42.1	43.4	42.5	43.3	44.5	45.8	44.7	45.6	46.8	48.3	46.8	47.8	49.1	50.7
	3360	Hi PR	240	258	272	284	269	289	305	319	306	329	347	362	348	375	396	413	392	422	445	464	433	466	492	513	
		Lo PR	97	104	113	121	103	110	120	127	107	114	124	132	112	120	131	139	118	125	137	146	122	130	142	151	

IDB: Entering Indoor Dry Bulb Temperature
 High and low pressures are measured at the liquid and suction access fittings.
 Shaded area reflects ACCA (TVA) Rating Conditions
 Amps: Unit amps (comp.+ evaporator + condenser fan motors)
 KW = Total system power

EXPANDED COOLING DATA — 12½ TONS (CONT.)

IDB	AIRFLOW	OUTDOOR AMBIENT TEMPERATURE												ENTERING INDOOR WET BULB TEMPERATURE													
		65				75				85				95				105				115					
		59	63	67	71	59	63	67	71	59	63	67	71	59	63	67	71	59	63	67	71	59	63	67	71		
80	4725	MBh	148.1	151.3	161.7	172.8	144.6	147.8	157.9	168.8	141.2	144.3	154.1	164.8	137.7	140.8	150.4	160.8	130.9	133.7	142.9	152.7	121.2	123.9	132.3	141.5	
		S/T	0.88	0.82	0.67	0.50	0.91	0.85	0.69	0.52	0.93	0.87	0.71	0.53	0.96	0.90	0.73	0.55	1.00	0.94	0.76	0.57	1.00	0.94	0.77	0.57	
		ΔT	25	24	21	17	26	25	21	17	26	25	21	17	26	25	21	17	25	24	21	17	24	23	20	16	
	4200	kW	10.58	10.81	11.15	11.51	11.40	11.64	12.02	12.41	12.12	12.38	12.78	13.21	12.75	13.03	13.46	13.91	13.29	13.59	14.04	14.51	13.76	14.06	14.53	15.03	
		Amps	36.8	37.5	38.4	39.6	39.1	39.8	40.9	42.1	41.8	42.6	43.7	45.1	44.1	45.0	46.2	47.6	46.4	47.3	48.7	50.2	48.7	49.7	51.1	52.7	
		Hi PR	252	271	286	299	283	304	321	335	322	346	365	381	366	394	416	434	412	443	468	488	455	490	517	539	
	3360	Lo PR	103	109	119	127	108	115	126	134	113	120	131	139	118	126	137	146	124	132	144	153	128	136	149	159	
		MBh	143.8	146.9	157.0	167.8	140.4	143.5	153.3	163.9	137.1	140.1	149.7	160.0	133.7	136.7	146.0	156.1	127.0	129.8	138.7	148.3	117.7	120.3	128.5	137.3	
		S/T	0.84	0.78	0.64	0.48	0.87	0.81	0.66	0.49	0.89	0.83	0.68	0.51	0.92	0.86	0.70	0.52	0.95	0.89	0.73	0.54	0.96	0.90	0.73	0.55	
	85	4725	ΔT	26	25	22	18	27	26	22	18	27	26	22	18	27	26	22	18	26	25	22	18	25	24	21	16
			kW	10.50	10.72	11.06	11.42	11.31	11.55	11.92	12.31	12.02	12.28	12.68	13.10	12.65	12.93	13.35	13.80	13.18	13.47	13.92	14.39	13.64	13.95	14.41	14.90
			Amps	36.5	37.2	38.2	39.3	38.8	39.6	40.6	41.8	41.5	42.3	43.4	44.7	43.8	44.6	45.9	47.3	46.1	47.0	48.3	49.8	48.3	49.3	50.7	52.3
4200		Hi PR	249	268	283	296	280	301	318	332	318	343	362	377	363	390	412	430	408	439	464	483	451	485	512	534	
		Lo PR	102	108	118	126	107	114	125	133	111	119	129	138	117	125	136	145	123	131	143	152	127	135	147	157	
		MBh	132.7	135.6	144.9	154.9	129.6	132.4	141.5	151.3	126.5	129.3	138.1	147.7	123.4	126.1	134.8	144.1	117.3	119.8	128.0	136.9	108.6	111.0	118.6	126.8	
3360		S/T	0.81	0.76	0.62	0.46	0.84	0.78	0.64	0.48	0.86	0.80	0.65	0.49	0.88	0.83	0.67	0.50	0.92	0.86	0.70	0.52	0.93	0.87	0.71	0.53	
		ΔT	29	28	24	19	30	28	25	20	30	28	25	20	30	29	25	20	29	28	25	20	28	26	23	18	
		kW	10.25	10.47	10.79	11.14	11.03	11.27	11.63	12.01	11.72	11.98	12.36	12.77	12.33	12.60	13.01	13.45	12.85	13.13	13.57	14.02	13.30	13.59	14.04	14.52	
4725		Amps	35.8	36.4	37.3	38.4	38.0	38.7	39.7	40.9	40.6	41.3	42.4	43.7	42.8	43.6	44.8	46.2	45.0	45.9	47.2	48.7	47.2	48.2	49.5	51.1	
		Hi PR	242	260	275	287	271	292	309	322	309	332	351	366	352	378	400	417	396	426	450	469	437	470	497	518	
		Lo PR	98	105	114	122	104	111	121	129	108	115	126	134	114	121	132	140	119	127	138	147	123	131	143	152	
85	4725	MBh	150.7	153.6	160.9	171.6	147.2	150.0	157.1	167.6	143.7	146.4	153.4	163.6	140.2	142.9	149.6	159.6	133.1	135.7	142.1	151.6	123.3	125.7	131.7	140.5	
		S/T	0.92	0.89	0.80	0.65	0.95	0.92	0.83	0.67	0.98	0.94	0.85	0.69	1.00	0.97	0.88	0.71	1.00	0.91	0.74	1.00	0.90	0.72	0.55		
		ΔT	27	26	25	22	27	27	25	22	27	27	25	22	27	27	26	22	26	26	25	22	24	24	24	20	
	4200	kW	10.67	10.89	11.24	11.60	11.49	11.74	12.12	12.51	12.22	12.48	12.89	13.32	12.86	13.14	13.57	14.03	13.40	13.70	14.16	14.63	13.87	14.18	14.66	15.16	
		Amps	37.0	37.7	38.7	39.8	39.4	40.1	41.2	42.4	42.1	42.9	44.1	45.4	44.4	45.3	46.5	48.0	46.8	47.7	49.0	50.6	49.1	50.1	51.5	53.1	
		Hi PR	254	274	289	302	286	307	324	338	325	349	369	385	370	398	420	438	416	448	473	493	460	495	522	545	
	3360	Lo PR	104	110	120	128	109	116	127	135	114	121	132	141	119	127	139	148	125	133	145	155	129	138	150	160	
		MBh	146.3	149.1	156.2	166.6	142.9	145.6	152.5	162.7	139.5	142.2	148.9	158.9	136.1	138.7	145.3	155.0	129.3	131.8	138.0	147.2	119.7	122.1	127.8	136.4	
		S/T	0.88	0.85	0.76	0.62	0.91	0.88	0.79	0.64	0.93	0.90	0.81	0.66	0.96	0.93	0.84	0.68	1.00	0.96	0.87	0.70	1.00	0.97	0.88	0.71	
	4725	ΔT	28	28	26	23	28	28	26	23	28	28	26	23	29	28	27	23	28	28	26	23	26	26	25	21	
		kW	10.58	10.81	11.15	11.51	11.40	11.64	12.02	12.41	12.12	12.38	12.78	13.21	12.75	13.03	13.46	13.91	13.29	13.59	14.04	14.51	13.76	14.06	14.53	15.03	
		Amps	36.8	37.5	38.4	39.6	39.1	39.8	40.9	42.1	41.8	42.6	43.7	45.1	44.1	45.0	46.2	47.6	46.4	47.3	48.7	50.2	48.7	49.7	51.1	52.7	
4200	Hi PR	252	271	286	299	283	304	321	335	322	346	365	381	366	394	416	434	412	443	468	488	455	490	517	539		
	Lo PR	103	109	119	127	108	115	126	134	113	120	131	139	118	126	137	146	124	132	144	153	128	136	149	159		
	MBh	135.0	137.6	144.1	153.8	131.9	134.4	140.8	150.2	128.7	131.2	137.4	146.6	125.6	128.0	134.1	143.0	119.3	121.6	127.4	135.9	110.5	112.7	118.0	125.9		
3360	S/T	0.85	0.82	0.74	0.60	0.88	0.85	0.76	0.62	0.90	0.87	0.78	0.63	0.93	0.89	0.81	0.65	0.96	0.93	0.84	0.68	0.97	0.94	0.84	0.69		
	ΔT	31	31	29	25	32	31	29	25	32	31	29	25	32	31	30	26	31	31	29	25	29	29	27	24		
	kW	10.33	10.55	10.88	11.23	11.12	11.36	11.72	12.10	11.82	12.08	12.47	12.88	12.43	12.71	13.12	13.56	12.96	13.24	13.68	14.14	13.41	13.71	14.16	14.64		
4725	Amps	36.0	36.7	37.6	38.7	38.3	39.0	40.0	41.2	40.9	41.6	42.8	44.1	43.1	43.9	45.1	46.5	45.3	46.3	47.5	49.0	47.6	48.5	49.9	51.5		
	Hi PR	244	263	278	290	274	295	312	325	312	336	354	370	355	382	404	421	400	430	454	474	442	475	502	523		
	Lo PR	99	106	116	123	105	112	122	130	109	116	127	135	115	122	133	142	120	128	140	149	124	132	144	154		

IDB: Entering Indoor Dry Bulb Temperature
 High and low pressures are measured at the liquid and suction access fittings.
 Shaded area reflects ACCA (TVA) Rating Conditions
 Amps: Unit amps (comp. + evaporator + condenser fan motors)
 KW = Total system power

AIRFLOW DATA — 7½ TONS

STANDARD BELT DRIVE — DOWN SHOT

ESP (" W.C.)	TURNS OPEN																	
	0			1			2			3			4			5		
	CFM	RPM	BHP	CFM	RPM	BHP	CFM	RPM	BHP	CFM	RPM	BHP	CFM	RPM	BHP	CFM	RPM	BHP
0.1										3522	750	1.14	3228	706	0.94	2964	661	0.73
0.3							3337	800	1.19	3102	756	1	2800	706	0.76	2504	661	0.59
0.5				3387	844	1.32	2834	806	0.99	2603	757	0.8						
0.7	3453	893	1.5	2903	850	1.12												
0.9	2957	899	1.29															

HIGH-STATIC BELT DRIVE — DOWN SHOT (FOR A MODELS ONLY)

ESP (" W.C.)	TURNS OPEN																	
	0			1			2			3			4			5		
	CFM	RPM	BHP	CFM	RPM	BHP	CFM	RPM	BHP	CFM	RPM	BHP	CFM	RPM	BHP	CFM	RPM	BHP
0.7																3575	904	1.66
0.9													3258	925	1.56	3113	909	1.41
1.1										3580	1013	1.97	3001	948	1.42	2722	915	1.25
1.3							3616	1063	2.17	3247	1019	1.79	2646	959	1.3			
1.5							3275	1069	2.05	2803	1025	1.68						
1.7				3346	1118	2.24	2885	1074	1.97									
1.9				3009	1125	2.05												
2.1																		

STANDARD BELT DRIVE — HORIZONTAL

ESP (" W.C.)	TURNS OPEN																	
	0			1			2			3			4			5		
	CFM	RPM	BHP	CFM	RPM	BHP	CFM	RPM	BHP	CFM	RPM	BHP	CFM	RPM	BHP	CFM	RPM	BHP
0.1													3381	703	0.99	3078	659	0.78
0.3							3560	796	1.26	3271	747	1.02	2946	703	0.82	2604	659	0.63
0.5				3492	841	1.36	3159	799	1.09	2819	752	0.86						
0.7	3453	891	1.5	3094	846	1.18												
0.9	2964	896	1.29	2524	852	0.96												
1.1	2537	902	1.08															

HIGH-STATIC BELT DRIVE — HORIZONTAL (FOR A MODELS ONLY)

ESP (" W.C.)	TURNS OPEN																	
	0			1			2			3			4			5		
	CFM	RPM	BHP	CFM	RPM	BHP	CFM	RPM	BHP	CFM	RPM	BHP	CFM	RPM	BHP	CFM	RPM	BHP
0.7																3567	903	1.58
0.9													3596	953	1.79	3145	906	1.39
1.1										3630	1007	1.97	3168	963	1.56	2675	909	1.18
1.3							3649	1063	2.19	3255	1021	1.8	2724	965	1.35			
1.5							3316	1068	2.0	2823	1058	1.61						
1.7				3287	1112	2.16	2869	1074	1.78									
1.9				2970	1122	2.0												
2.1				2644	1133	1.92												

Notes :

Assume dry coil with filter in place; CFM correction for wet coil = 3%

Any adjustment made to the blower should not cause the motor to draw more than the motor rated RLA. Applications that exceed the above could require a larger motor. Minimum rated SCFM is 350 per ton.

AIRFLOW DATA — 8½ TONS

STANDARD BELT DRIVE -- DOWN SHOT

ESP (" W.C.)	TURNS OPEN																	
	0			1			2			3			4			5		
	CFM	RPM	BHP	CFM	RPM	BHP	CFM	RPM	BHP	CFM	RPM	BHP	CFM	RPM	BHP	CFM	RPM	BHP
0.1										3372	747	1.11	3078	703	0.91	2814	658	0.70
0.3							3187	797	1.16	2952	753	0.97	2650	703	0.73			
0.5				3237	841	1.29	2684	803	0.96	2453	754	0.77						
0.7	3303	890	1.47	2753	847	1.09												
0.9	2807	896	1.26															

HIGH-STATIC BELT DRIVE -- DOWN SHOT

ESP (" W.C.)	TURNS OPEN																	
	0			1			2			3			4			5		
	CFM	RPM	BHP	CFM	RPM	BHP	CFM	RPM	BHP	CFM	RPM	BHP	CFM	RPM	BHP	CFM	RPM	BHP
0.7																3425	901	1.63
0.9													3108	922	1.53	2963	906	1.38
1.1										3430	1010	1.94	2851	945	1.39	2572	912	1.22
1.3							3466	1060	2.14	3097	1016	1.76	2496	956	1.27			
1.5							3125	1066	2.02	2653	1022	1.65						
1.7				3196	1115	2.21	2735	1071	1.94									
1.9	3251	1160	2.36	2859	1122	2.02												
2.1	2914	1167	2.17															

STANDARD BELT DRIVE -- HORIZONTAL

ESP (" W.C.)	TURNS OPEN																	
	0			1			2			3			4			5		
	CFM	RPM	BHP	CFM	RPM	BHP	CFM	RPM	BHP	CFM	RPM	BHP	CFM	RPM	BHP	CFM	RPM	BHP
0.1													3231	700	0.96	2928	656	0.75
0.3							3410	793	1.23	3121	744	0.99	2796	700	0.79			
0.5				3342	838	1.33	3009	796	1.06	2669	749	0.83						
0.7	3303	888	1.47	2944	843	1.15												
0.9	2814	893	1.26															

HIGH-STATIC BELT DRIVE -- HORIZONTAL

ESP (" W.C.)	TURNS OPEN																	
	0			1			2			3			4			5		
	CFM	RPM	BHP	CFM	RPM	BHP	CFM	RPM	BHP	CFM	RPM	BHP	CFM	RPM	BHP	CFM	RPM	BHP
0.7																3417	900	1.55
0.9													3446	950	1.76	2995	903	1.36
1.1										3480	1004	1.94	3018	960	1.53	2525	906	1.15
1.3							3499	1060	2.16	3105	1018	1.77	2574	962	1.32			
1.5							3166	1065	1.97	2673	1055	1.58						
1.7				3137	1109	2.13	2719	1071	1.75									
1.9	3107	1154	2.28	2820	1119	1.97												
2.1	2790	1164	2.12															

Notes :

Assume dry coil with filter in place; CFM correction for wet coil = 3%

Any adjustment made to the blower should not cause the motor to draw more than the motor rated RLA. Applications that exceed the above could require a larger motor. Minimum rated SCFM is 350 per ton.

AIRFLOW DATA — 10 TONS

STANDARD BELT-DRIVE DOWN SHOT

ESP (" W.C.)	TURNS OPEN																	
	0			1			2			3			4			5		
	CFM	RPM	BHP	CFM	RPM	BHP	CFM	RPM	BHP	CFM	RPM	BHP	CFM	RPM	BHP	CFM	RPM	BHP
0.2							4316	780	1.57	4118	738	1.36	3771	687	1.08	3376	644	0.85
0.4				4282	830	1.76	3928	786	1.4	3595	740	1.13						
0.6	4232	874	1.87	3872	830	1.52	3444	786	1.2									
0.8	3839	880	1.64	3367	836	1.27												
1	3326	885	1.4															
1.2																		
1.4																		

HIGH-STATIC BELT-DRIVE DOWN SHOT

ESP (" W.C.)	TURNS OPEN																	
	0			1			2			3			4			5		
	CFM	RPM	BHP	CFM	RPM	BHP	CFM	RPM	BHP	CFM	RPM	BHP	CFM	RPM	BHP	CFM	RPM	BHP
0.8													4188	943	2.11	3793	889	1.67
1										4305	1002	2.39	3836	946	1.89	3416	893	1.45
1.2							4324	1053	2.63	3879	1003	2.11	3425	951	1.63			
1.4				4428	1109	2.92	3973	1056	2.35	3434	1009	1.8						
1.6	4465	1160	3.2	4088	1113	2.67	3506	1068	2.1									
1.8	4129	1168	2.9	3625	1122	2.3												
2	3694	1175	2.65															

STANDARD BELT-DRIVE HORIZONTAL

ESP (" W.C.)	TURNS OPEN																	
	0			1			2			3			4			5		
	CFM	RPM	BHP	CFM	RPM	BHP	CFM	RPM	BHP	CFM	RPM	BHP	CFM	RPM	BHP	CFM	RPM	BHP
0.2										4391	737	1.48	4054	693	1.22	3760	645	0.97
0.4							4314	781	1.61	3969	737	1.29	3534	693	1			
0.6				4255	826	1.69	3894	781	1.38	3447	743	1.09						
0.8	4234	876	1.85	3792	832	1.47												
1	3724	877	1.59															
1.2																		
1.4																		

HIGH-STATIC BELT-DRIVE HORIZONTAL

ESP (" W.C.)	TURNS OPEN																	
	0			1			2			3			4			5		
	CFM	RPM	BHP	CFM	RPM	BHP	CFM	RPM	BHP	CFM	RPM	BHP	CFM	RPM	BHP	CFM	RPM	BHP
0.8																4408	885	2.02
1													4464	940	2.29	3929	891	1.76
1.2										4585	996	2.58	4026	946	2	3436	897	1.46
1.4							4697	1049	2.92	4141	1001	2.26	3509	951	1.7			
1.6							4264	1056	2.58	3663	1007	1.96						
1.8				4359	1105	2.85	3785	1061	2.22									
2				3907	1114	2.49												

Notes :

Assume dry coil with filter in place; CFM correction for wet coil = 3%

Any adjustment made to the blower should not cause the motor to draw more than the motor rated RLA. Applications that exceed the above could require a larger motor. Minimum rated SCFM is 350 per ton.

AIRFLOW DATA — 12½ TONS

STANDARD BELT DRIVE --- DOWN SHOT

ESP (" W.C.)	TURNS OPEN											
	0		1		2		3		4		5	
	CFM	BHP	CFM	BHP	CFM	BHP	CFM	BHP	CFM	BHP	CFM	BHP
0.2	5514	2.92	5604	3.22	5064	2.16	4775	1.81	4514	1.49	4271	1.23
0.4	5279	2.74	5110	2.40	4696	1.94	4447	1.63	4123	1.31		
0.6	5185	2.67	4813	2.20	4352	1.74	4039	1.43				
0.8	4766	2.37	4526	2.02								
1.0	4223	2.01										

HIGH-STATIC BELT DRIVE --- DOWN SHOT

ESP (" W.C.)	TURNS OPEN											
	0		1		2		3		4		5	
	CFM	BHP	CFM	BHP	CFM	BHP	CFM	BHP	CFM	BHP	CFM	BHP
0.6									5515	3.21	5124	2.68
0.8					5840	4.06	5781	3.73	5344	3.07	4721	2.37
1.0			5908	4.49	5643	3.86	5369	3.36	4887	2.71	4365	2.13
1.2	5869	4.74	5542	4.11	5229	3.47	4853	2.92	4404	2.35	3986	1.88
1.4	5464	4.30	5180	3.75	4917	3.19	4584	2.71	4197	2.21		
1.6	5229	4.05	4960	3.53	4397	2.75	4204	2.41				
1.8	4961	3.78	4553	3.16								
2.0	4790	3.61	4315	2.95								

STANDARD BELT DRIVE --- HORIZONTAL

ESP (" W.C.)	TURNS OPEN											
	0		1		2		3		4		5	
	CFM	BHP	CFM	BHP	CFM	BHP	CFM	BHP	CFM	BHP	CFM	BHP
0.2	5762	3.08	5485	2.63	5140	2.21	4855	1.84	4513	1.48	4197	1.20
0.4	5550	2.91	5207	2.44	4857	2.03	4489	1.64	4100	1.29		
0.6	5202	2.65	4922	2.25	4487	1.81	4113	1.45				
0.8	4898	2.43	4515	1.99	4074	1.58						
1.0	4549	2.20	4135	1.76								
1.2	4258	2.01										

HIGH-STATIC BELT DRIVE --- HORIZONTAL

ESP (" W.C.)	TURNS OPEN											
	0		1		2		3		4		5	
	CFM	BHP	CFM	BHP	CFM	BHP	CFM	BHP	CFM	BHP	CFM	BHP
0.6							5967	3.92	5451	3.16	5275	2.77
0.8							5628	3.61	5223	2.97	4959	2.54
1.0					5840	4.10	5385	3.39	4999	2.80	4635	2.31
1.2					5643	3.90	5003	3.06	4803	2.65	4160	1.99
1.4	6007	4.93	5740	4.32	5229	3.51	4576	2.71	4440	2.38		
1.6	5752	4.64	5401	3.97	4917	3.23						
1.8	5380	4.24	5033	3.61	4397	2.79						
2.0	5065	3.91	4573	3.18								

NOTES

- Assume dry coil with filter in place; CFM correction for wet coil = 3%
- Any adjustment made to the blower should not cause the motor to draw more than the motor rated RLA. Application
- that exceed the above could require a larger motor. Minimum rated SCFM is 350 per ton.

DIMENSIONS

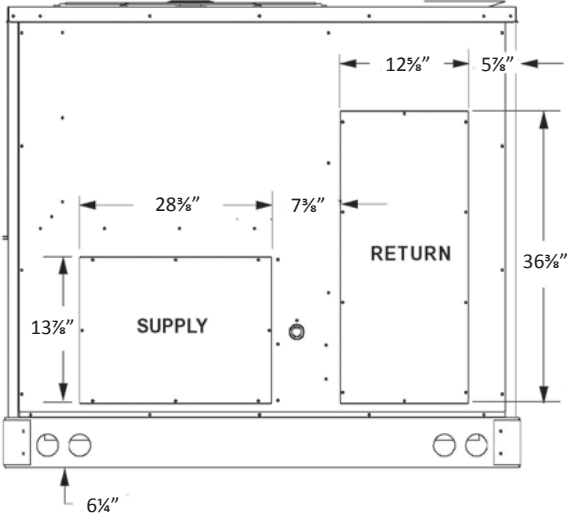
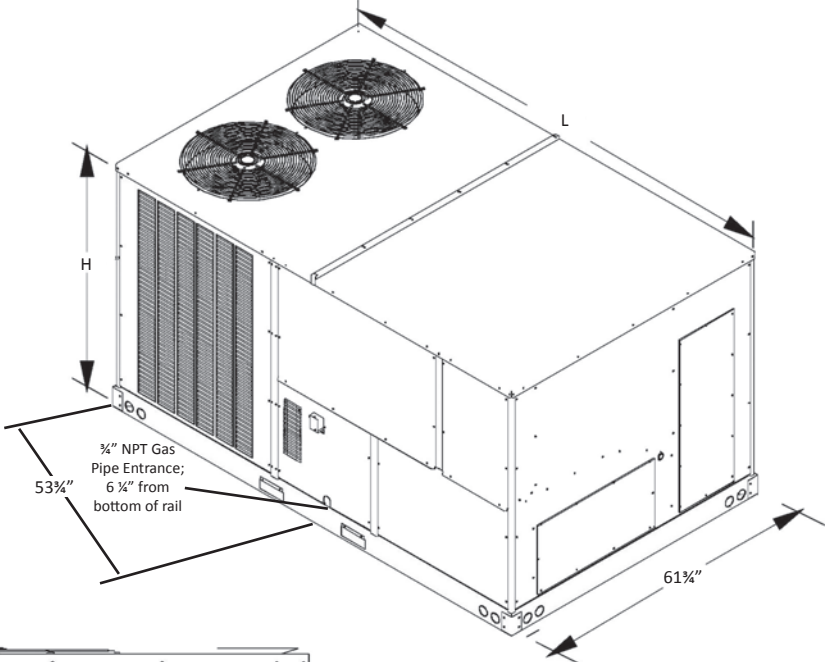

Horizontal Discharge

MODEL SIZE	DIMENSIONS	
	H	L
7½ to 10 Tons	52 $\frac{7}{8}$ "	99 $\frac{1}{8}$ "
12½ Tons	58 $\frac{3}{8}$ "	99 $\frac{1}{8}$ "

UNIT CLEARANCES

Maintain an adequate clearance around the unit for safety, service, maintenance, and proper unit operation. Leave a total clearance of 75" on the main control panel side of the unit for possible removal of fan shaft, coil, electric heat, and gas furnace. Leave a clearance of 48" on all other sides of the unit for possible compressor removal or service access, and to ensure proper ventilation and condenser airflow. Do not install the unit beneath any obstruction. Install the unit away from all building exhausts to inhibit ingestion of exhaust air into the unit's fresh-air intake.

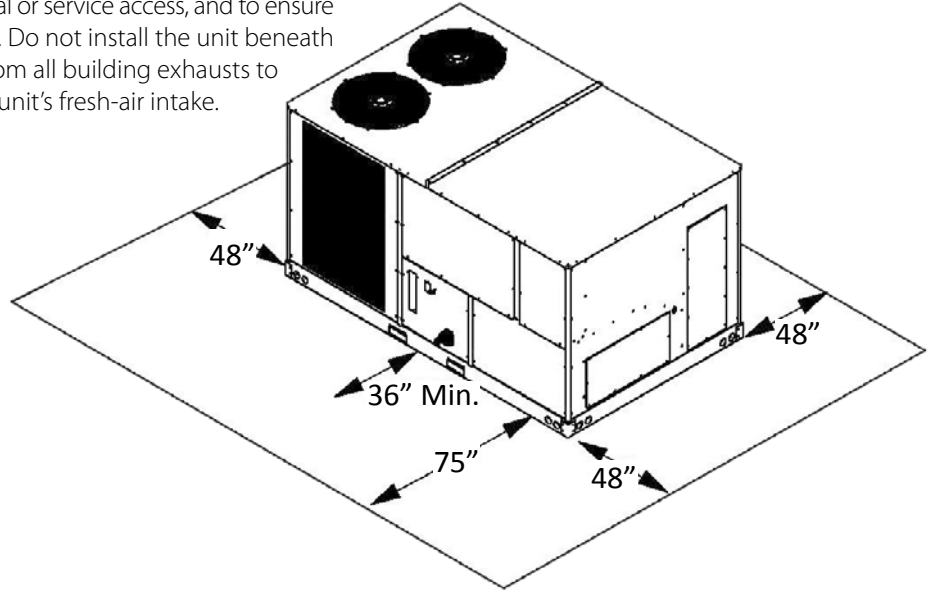

ELECTRICAL ENTRANCE LOCATIONS

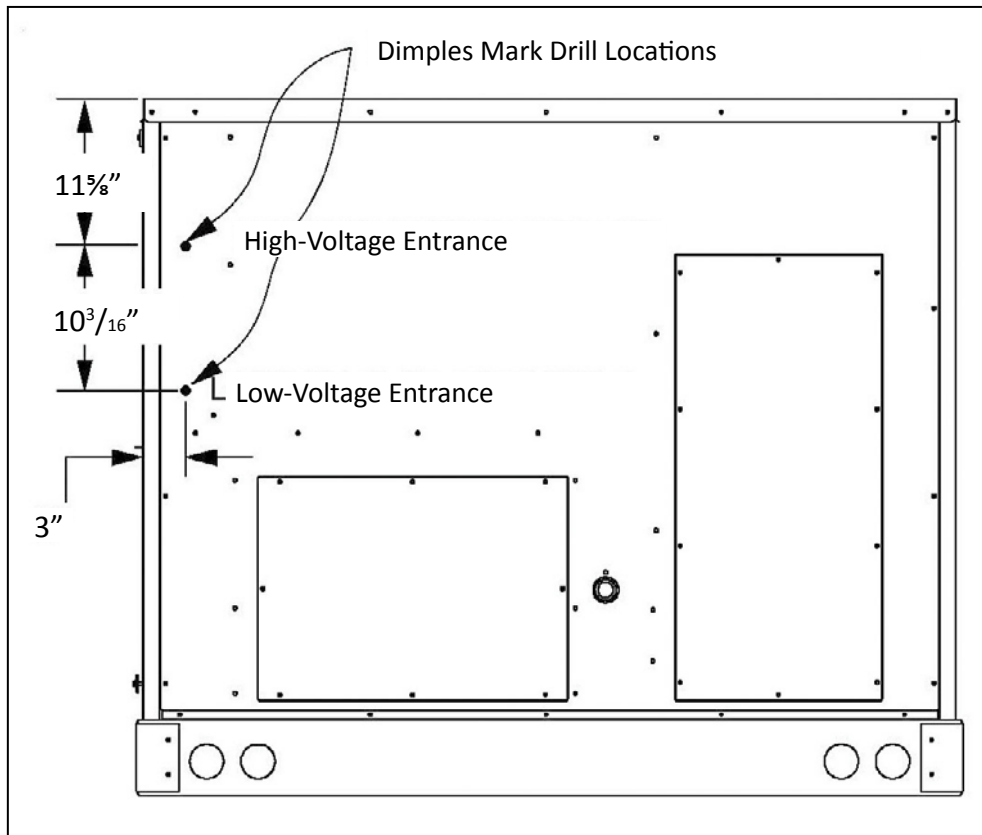

ROOF CURB INSTALLATION — RIGGING

Provisions for forks have been included in the unit base frame. No other fork locations are approved.

- Unit must be lifted by the four lifting holes located at the base frame corners.
- Lifting cables should be attached to the unit with shackles.
- The distance between the crane hook and the top of the unit must not be less than 60".
- Two spreader bars must span over the unit to prevent damage to the cabinet by the lift cables. Spreader bars must be of sufficient length so that cables do not come in contact with the unit during transport. Remove wood struts mounted beneath unit base frame before setting unit on roof curb. These struts are intended to protect unit base frame from fork lift damage. To remove the struts, extract the sheet metal retainers and pull the struts through the base of the unit. Refer to rigging label on the unit.

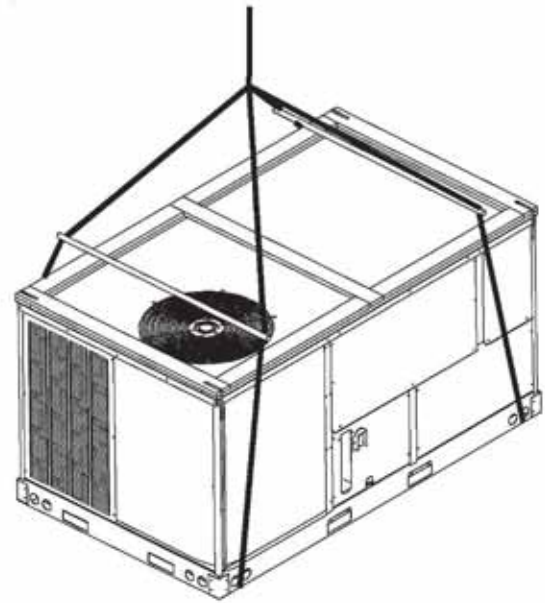

Important: If using bottom discharge with roof curb, duct-work should be attached to the curb prior to installing the unit. Duct-work dimensions are shown in Roof Curb Installation Instructions Manual.

Refer to the Roof Curb Installation Instructions for proper curb installation. Curbing must be installed in compliance with the National Roofing Contractors Association Manual.

Lower unit carefully onto roof mounting curb. While rigging the unit, the center of gravity will cause the condenser end to be lower than the supply air end.

Bring condenser end of unit into alignment with the curb. With condenser end of the unit resting on curb member and using curb as a fulcrum, lower opposite end of the unit until entire unit is seated on the curb. When a rectangular cantilever curb is used, take care to center the unit. Check for proper alignment and orientation of supply and return openings with duct.

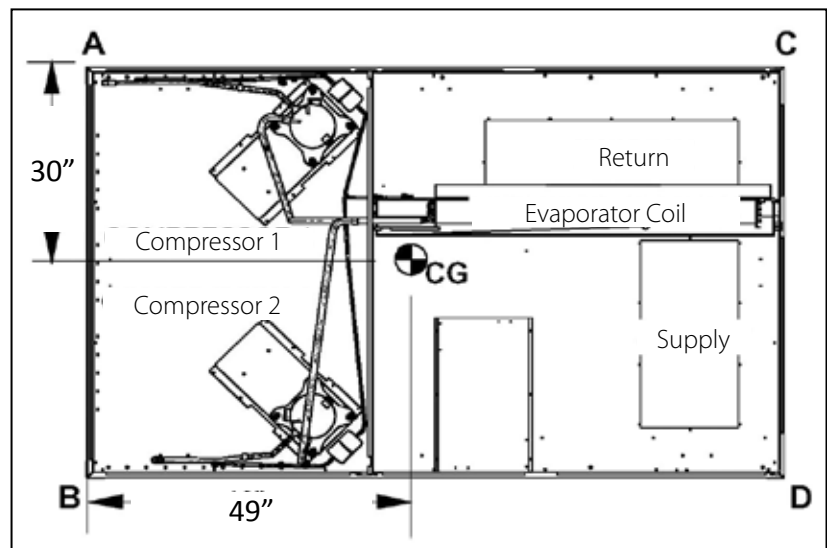

CORNER & CENTER-OF-GRAVITY LOCATIONS

WEIGHT TYPES	7½-TON AA REV WEIGHTS (LBS)	7½-TON BA REV & 8½-TON WEIGHTS (LBS)	10-TON WEIGHTS (LBS)	12½-TON WEIGHTS (LBS)
Weight A	225	195	230	335
Weight B	325	270	330	390
Weight C	275	240	280	295
Weight D	400	330	405	345
Shipping Weight	1250	1055	1275	1390
Operating Weight	1210	1030	1235	1365

To assist in determining rigging requirements, unit weights are shown to the right.

Note: These weights are calculated without accessories installed.

ROOF CURB INSTALLATION (CONT.)

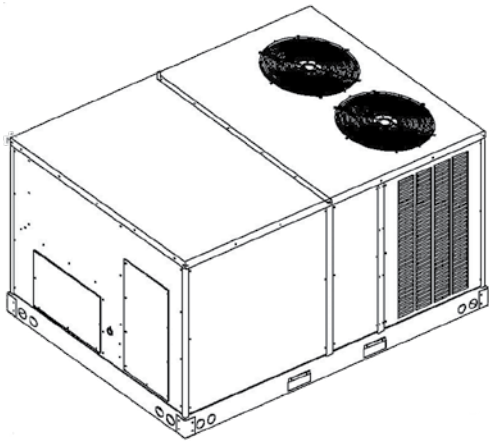

Curb installations must comply with local codes and should follow the established guidelines of the National Roofing Contractors Association.

Proper unit installation requires that the roof curb be firmly and permanently attached to the roof structure. Check for adequate fastening method prior to setting the unit on the curb.

Full perimeter roof curbs are available from the factory and are shipped unassembled. The installing contractor is responsible for field assembly, squaring, leveling, and mounting on the roof structure. All required hardware necessary for the assembly of the sheet metal curb is included in the curb accessory package.

- Determine sufficient structural support before locating and mounting the curb and package unit.
- Duct-work must be constructed using industry guidelines. The duct-work must be placed into the roof curb before mounting the package unit. Our full perimeter curbs include duct connection frames to be assembled with the curb. Cantilevered-type curbs are not available from the factory.

3-D VIEW

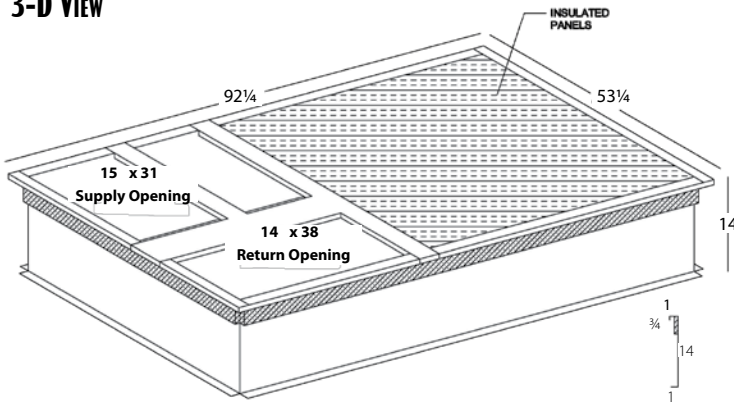

- Contractor furnishes curb insulation, cant strips, flashing, and general roofing material.
- Support curbs on parallel sides with roof members. To prevent damage to the unit, the roof members cannot penetrate supply and return duct openings.

Note: The unit and curb accessories are designed to allow vertical duct installation before unit placement. Duct installation after unit placement is not recommended.

See the manual shipped with the roof curb for assembly and installation instructions.

TOP VIEW

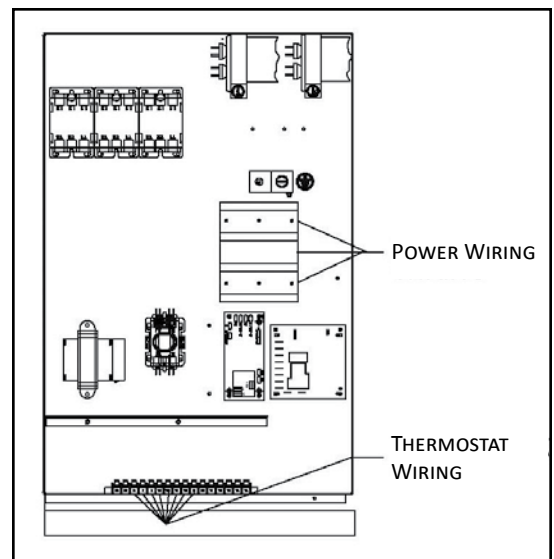
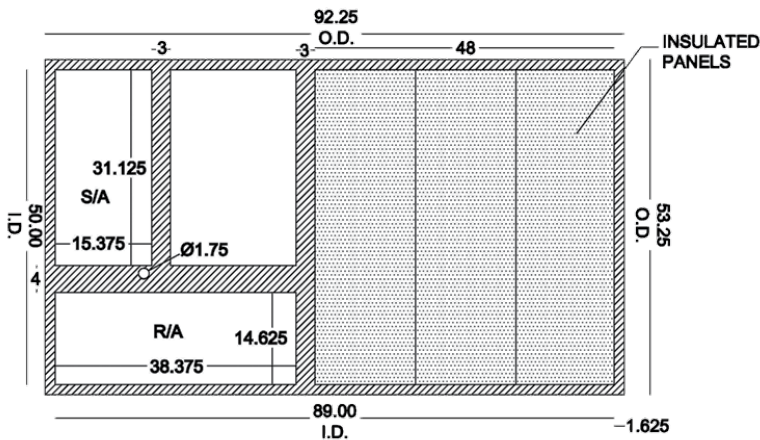

POWER AND LOW-VOLTAGE BLOCK LOCATIONS

WIRING DIAGRAM — CPG090-120***3B*** (FOR MODELS WITH SERIAL NUMBERS 0907 AND BELOW)

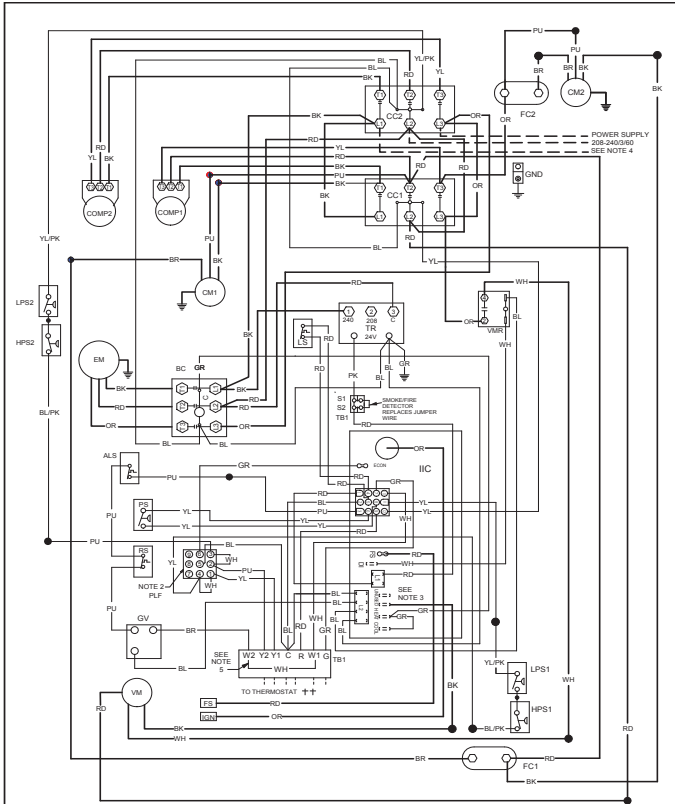

0140L00087 REV C

COMPONENT LEGEND

- ALS AUXILIARY LIMIT SWITCH
- BC BLOWER CONTACTOR
- CC COMPRESSOR CONTACTOR
- CM CONDENSER MOTOR
- COMP COMPRESSOR
- EM EVAPORATOR MOTOR
- F FUSE
- FC FAN CAPACITOR
- FS FLAME SENSOR
- GND EQUIPMENT GROUND
- GV GAS VALVE
- HPS1 HIGH PRESSURE SWITCH
- IBR INDOOR BLOWER RELAY
- IC INTEGRATED IGNITION CONTROL
- IGN IGNITOR
- LPS1 LOW PRESSURE SWITCH
- LS LIMIT SWITCH
- PLF FEMALE PLUG/CONNECTOR
- PS PRESSURE SWITCH
- RS ROLLOUT SWITCH
- TR1 TRANSFORMER
- VM VENT MOTOR
- VMR VENT MOTOR RELAY

NOTES

1. REPLACEMENT WIRE MUST BE THE SAME SIZE AND TYPE OF INSULATION AS ORIGINAL. (USE COPPER CONDUCTOR ONLY).
2. ACCESSORY ECONOMIZER PLUG ADJACENT TO BLOWER HOUSING IN RETURN AIR COMPARTMENT. REMOVE MALE PLUG AND ATTACH FEMALE PLUG TO THE ECONOMIZER ACCESSORY.
3. L1 AND L2 ON IIC CONTROL IS 24V INPUT.
4. USE COPPER CONDUCTORS ONLY.
5. FOR TWO STAGE OPERATION REMOVE W1 TO W2 JUMPER WIRE.

INSTALLER/SERVICEMAN

THE STATUS LIGHT ON THE FURNACE CONTROL MAY BE USED AS A GUIDE TO TROUBLESHOOTING THIS APPLIANCE. STATUS LIGHT CODES ARE AS FOLLOWS:

STATUS LIGHT	EQUIPMENT STATUS	CHECK
ON	NORMAL OPERATION	
OFF	NO POWER OR INTERNAL CONTROL	CHECK INPUT POWER CHECK FUSE OR CONTROL REPLACE CONTROL
1 BLINK	IGNITION FAILURE OPEN ROLLOUT SWITCH OPEN AUX. LIMIT SWITCH	GAS FLOW GAS PRESSURE FLAME SENSOR FLAME ROLLOUT BAD SWITCH
2 BLINKS	PRESSURE SWITCH OPEN	PRESSURE SWITCH CHECK
3 BLINKS	PRESSURE SWITCH CLOSED WITHOUT INDICATOR ON	PRESSURE SWITCH CHECK
4 BLINKS	OPEN LIMIT SWITCH	MAIN LIMIT OPEN
5 BLINKS	FALSE FLAME SENSED	BAD SWITCH
6 BLINKS	COMPRESSOR OUTPUT DELAY	STOP GAS VALVE 3 MIN. COMP ANTI-CYCLE TIMER

FACTORY WIRING

- LINE VOLTAGE
- - - LOW VOLTAGE
- · - · - OPTIONAL HIGH VOLTAGE

FIELD WIRING

- - - HIGH VOLTAGE
- · - · - LOW VOLTAGE

WIRE CODE

- BK BLACK
- BL BLUE
- BR BROWN
- GR GREEN
- OR ORANGE
- PK PINK
- PJ PURPLE
- RD RED
- WH WHITE
- YL YELLOW
- YL.PK YELLOW WITH PINK STRIP
- BL.PK BLUE WITH PINK STRIP

THERMOSTAT FIELD WIRING

++

2 STAGE COOLING

- W1 — W1
- W2 — W2
- W3 — W3
- W4 — W4
- W5 — W5
- W6 — W6
- W7 — W7
- W8 — W8
- W9 — W9
- W10 — W10
- W11 — W11
- W12 — W12
- W13 — W13
- W14 — W14
- W15 — W15
- W16 — W16
- W17 — W17
- W18 — W18
- W19 — W19
- W20 — W20
- W21 — W21
- W22 — W22
- W23 — W23
- W24 — W24
- W25 — W25
- W26 — W26
- W27 — W27
- W28 — W28
- W29 — W29
- W30 — W30
- W31 — W31
- W32 — W32
- W33 — W33
- W34 — W34
- W35 — W35
- W36 — W36
- W37 — W37
- W38 — W38
- W39 — W39
- W40 — W40
- W41 — W41
- W42 — W42
- W43 — W43
- W44 — W44
- W45 — W45
- W46 — W46
- W47 — W47
- W48 — W48
- W49 — W49
- W50 — W50
- W51 — W51
- W52 — W52
- W53 — W53
- W54 — W54
- W55 — W55
- W56 — W56
- W57 — W57
- W58 — W58
- W59 — W59
- W60 — W60
- W61 — W61
- W62 — W62
- W63 — W63
- W64 — W64
- W65 — W65
- W66 — W66
- W67 — W67
- W68 — W68
- W69 — W69
- W70 — W70
- W71 — W71
- W72 — W72
- W73 — W73
- W74 — W74
- W75 — W75
- W76 — W76
- W77 — W77
- W78 — W78
- W79 — W79
- W80 — W80
- W81 — W81
- W82 — W82
- W83 — W83
- W84 — W84
- W85 — W85
- W86 — W86
- W87 — W87
- W88 — W88
- W89 — W89
- W90 — W90
- W91 — W91
- W92 — W92
- W93 — W93
- W94 — W94
- W95 — W95
- W96 — W96
- W97 — W97
- W98 — W98
- W99 — W99
- W100 — W100

208-240/3/60 0140L00088 REV C

WARNING

⚡

High Voltage: Disconnect all power before servicing or installing this unit. Multiple power sources may be present. Failure to do so may cause property damage, personal injury, or death.

Wiring is subject to change. Always refer to the wiring diagram or the unit for the most up-to-date wiring.

WIRING DIAGRAM — CPG090-120***4B (FOR MODELS WITH SERIAL NUMBERS 0907 AND BELOW)

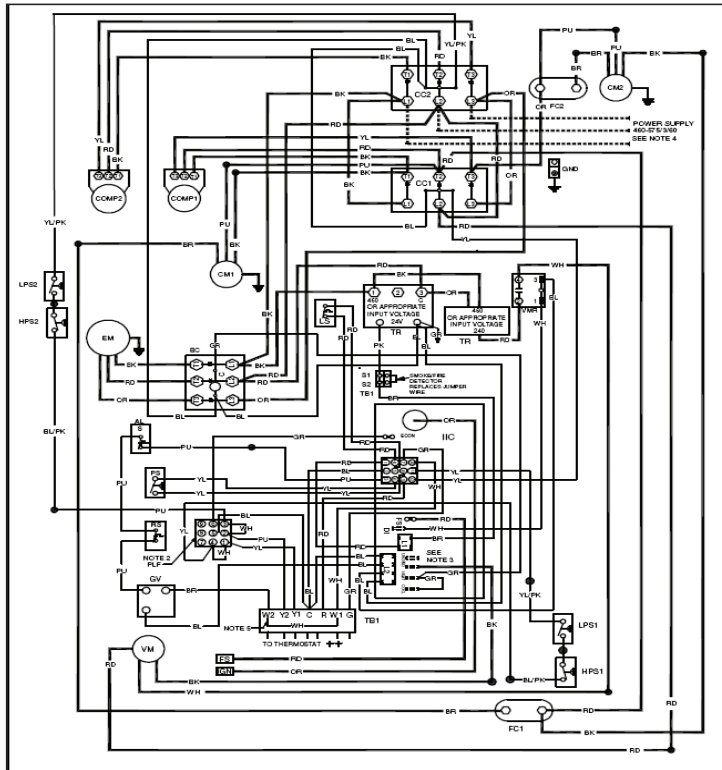

0140L00089 REV D

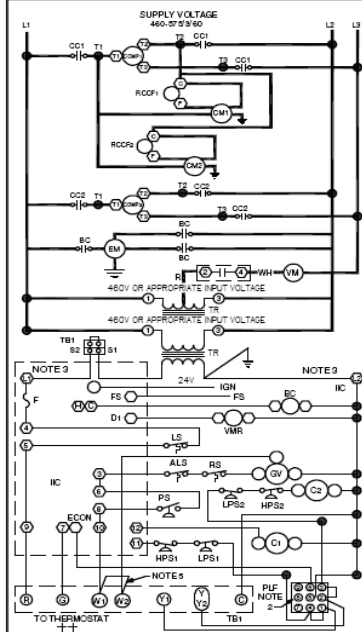

- COMPONENT LEGEND**
- ALS AUXILIARY LIMIT SWITCH
 - BC BLOWER CONTACTOR
 - COMP COMPRESSOR
 - CM CONDENSER MOTOR
 - CC COMPRESSOR CONTACTOR
 - EM EVAPORATOR MOTOR
 - F FUSE
 - FC FAN CAPACITOR
 - FS FLAME SENSOR
 - GND EQUIPMENT GROUND
 - GV GAS VALVE
 - HPS HIGH PRESSURE SWITCH
 - IBR INDOOR BLOWER RELAY
 - IC INTEGRATED IGNITION CONTROL
 - IGN IGNITOR
 - LPS LOW PRESSURE SWITCH
 - LS LIMIT SWITCH
 - PUF FEMALE PLUG/CONNECTOR
 - PS PRESSURE SWITCH
 - RS ROLLOUT SWITCH
 - TB1 TERMINAL BLOCK (DAY SIGNAL)
 - TR TRANSFORMER
 - VM VENT MOTOR
 - VMR VENT MOTOR RELAY

- NOTES**
1. REPLACEMENT WIRE MUST BE THE SAME SIZE AND TYPE OF INSULATION AS ORIGINAL. (USE COPPER CONDUCTOR ONLY).
 2. ACCESSORY ECONOMIZER PLUG/ADJUNCT TO BLOWER HOUSING IN RETURN AIR COMPARTMENT. REMOVE MALE PLUG AND ATTACH FEMALE PLUG TO THE ECONOMIZER ACCESSORY.
 3. L1 AND L2 ON IIC CONTROL IS 24V INPUT.
 4. USE COPPER CONDUCTORS ONLY. *** USE REC. CLASS 2 WIRE.
 5. FOR TWO STAGE OPERATION REMOVE W1 TO W2 WIRE JUMPER.

- FACTORY WIRING**
- LINE VOLTAGE
 - LOW VOLTAGE
 - OPTIONAL
 - HIGH VOLTAGE
 - LOW VOLTAGE
- FIELD WIRING**
- HIGH VOLTAGE
 - LOW VOLTAGE
- WIRE CODE**
- BK BLACK
 - BL BLUE
 - BR BRN/WH
 - GR GREEN
 - OR ORANGE
 - PK PINK
 - PU PURPLE
 - RD RED
 - WH WHITE
 - YL YELLOW
 - YLPK YELLOW WITH PINK STRIP
 - BLPK BLUE WITH PINK STRIP

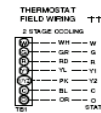

INSTALLER/SERVICEMAN

THE STATUS LIGHT ON THE FRONT CONTROL MAY BE USED AS A GUIDE TO TROUBLESHOOTING THIS APPLIANCE. STATUS LIGHT CODES ARE AS FOLLOWS:

STATUS LIGHT	EQUIPMENT STATUS	CHECK
ON	NORMAL OPERATION	
OFF	NO POWER OR INTERNAL CONTROL	CHECK INPUT POWER CHECK FUSE ON CONTROL REPLACE CONTROL
1 BLINK	IGNITION FAILURE OPEN ROLLOUT SWITCH OPEN ALS LIMIT SWITCH	CHECK GAS FLOW GAS PRESSURE GAS VALVE FLAME SENSOR FLAME ROLLOUT BK SWITCH ALS LIMIT OPEN
2 BLINKS	PRESSURE SWITCH OPEN	CHECK PRESSURE SWITCH
3 BLINKS	PRESSURE SWITCH CLOSED WITHOUT INDOOR ON	CHECK PRESSURE SWITCH
4 BLINKS	OPEN LIMIT SWITCH	CHECK MAIN LIMIT OPEN
5 BLINKS	FALSE FLAME SENSED	STUCK GAS VALVE
6 BLINKS	COMPRESSOR OUTPUT DELAY	3 MIN COMP ANTI-CYCLE TIMER

460-575/3/60 0140L00089 REV D

WARNING

High Voltage: Disconnect all power before servicing or installing this unit. Multiple power sources may be present. Failure to do so may cause property damage, personal injury, or death.

Wiring is subject to change. Always refer to the wiring diagram or the unit for the most up-to-date wiring.

WIRING DIAGRAM — CPG090***4B/7B***

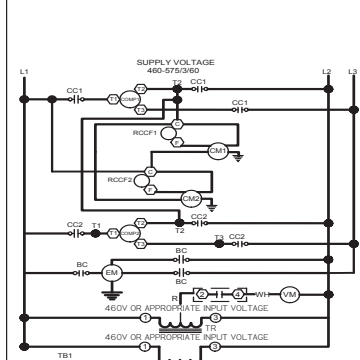
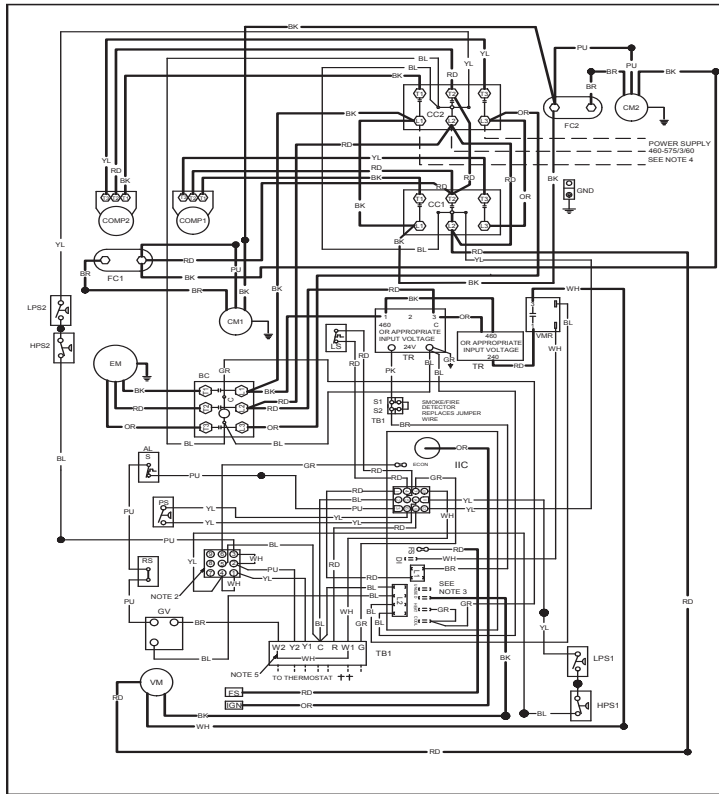

- COMPONENT LEGEND**
- ALS AUXILIARY LIMIT SWITCH
 - BC BLOWER CONTACTOR
 - COMP COMPRESSOR
 - CM CONDENSER MOTOR
 - CC COMPRESSOR CONTACTOR
 - EM EVAPORATOR MOTOR
 - F FUSE
 - FC FAN CAPACITOR
 - FS FLAME SENSOR
 - EG EQUIPMENT GROUND
 - GV GAS VALVE
 - HPS HIGH PRESSURE SWITCH
 - BR BLOWER BLOWER RELAY
 - IIC INTEGRATED IGNITION CONTROL
 - LS LOW PRESSURE SWITCH
 - LS LIMIT SWITCH
 - PLF FEMALE PLUG/CONNECTOR
 - PS PRESSURE SWITCH
 - RS ROLLOUT SWITCH
 - TB1 TERMINAL BLOCK (24V SIGNAL)
 - TR TRANSFORMER
 - VM VENT MOTOR
 - VMR VENT MOTOR RELAY

- FACTORY WIRING**
- LINE VOLTAGE
 - LOW VOLTAGE
 - - - OPTIONAL
 - HIGH VOLTAGE
- FIELD WIRING**
- HIGH VOLTAGE
 - - - LOW VOLTAGE
- WIRE CODE**
- BL BLACK
 - BL BLUE
 - BR BROWN
 - GR GREEN
 - OR ORANGE
 - PK PINK
 - PJ PURPLE
 - RD RED
 - WH WHITE
 - YL YELLOW
 - YL/PK YELLOW WITH PINK STRIP
 - BL/PK BLUE WITH PINK STRIP

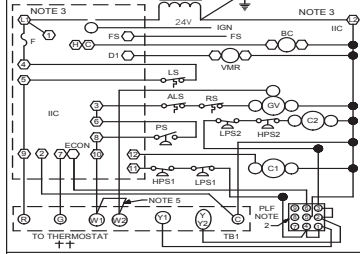

- NOTES**
1. REPLACEMENT WIRE MUST BE THE SAME SIZE AND TYPE OF INSULATION AS ORIGINAL. (USE COPPER CONDUCTOR ONLY).
 2. ACCESSORY ECONOMIZER PLUG ADJACENT TO BLOWER HOUSING IN RETURN AIR COMPARTMENT. REMOVE MALE PLUG AND ATTACH FEMALE PLUG TO THE ECONOMIZER ACCESSORY.
 3. L1 AND L2 ON IIC CONTROL IS 24V INPUT.
 4. USE COPPER CONDUCTORS ONLY.
 5. USE REC CLASS 2 WIRE.
 6. FOR TWO STAGE OPERATION REMOVE W1 TO W2 WIRE JUMPER.

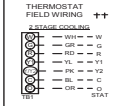

INSTALLER/SERVICEMAN

THE STATUS LIGHT ON THE FURNACE CONTROL MAY BE USED AS A GUIDE TO TROUBLESHOOTING THIS APPLIANCE. STATUS LIGHT CODES ARE AS FOLLOWS:

STATUS LIGHT	EQUIPMENT STATUS	CHECK
ON	NORMAL OPERATION	
OFF	NO POWER OR INTERNAL CONTROL	CHECK INPUT POWER CHECK FUSE ON CONTROL REPLACE CONTROL
1 BLINK	IGNITION FAILURE	GAS FLOW GAS PRESSURE FLAME SENSOR FLAME ROLLOUT BAD SWITCH AUX LIMIT OPEN
2 BLINKS	PRESSURE SWITCH OPEN	CHECK PRESSURE SWITCH
3 BLINKS	PRESSURE SWITCH CLOSED WITHOUT INDICATOR ON	CHECK PRESSURE SWITCH
4 BLINKS	OPEN LIMIT SWITCH	MAIN LIMIT OPEN BANK SWITCH
5 BLINKS	FALSE FLAME SENSED	STICKING GAS VALVE
6 BLINKS	COMPRESSOR OUTPUT DELAY	3 MIN COMP ANTI-CYCLE TIMER

460-575/3/60 014L00551 REV B

WARNING

High Voltage: Disconnect all power before servicing or installing this unit. Multiple power sources may be present. Failure to do so may cause property damage, personal injury, or death.

Wiring is subject to change. Always refer to the wiring diagram or the unit for the most up-to-date wiring.

WIRING DIAGRAM — CPG150***4B/7B***

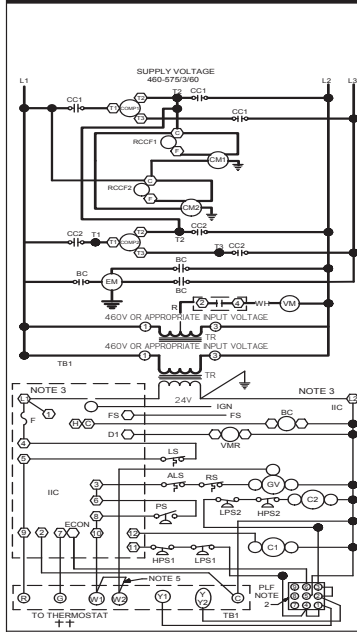
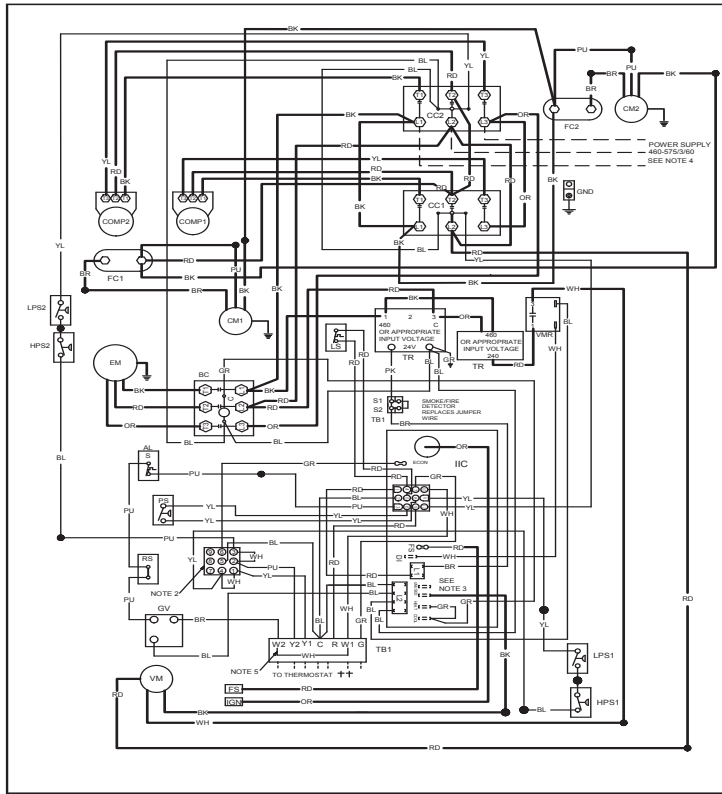

COMPONENT LEGEND

- ALS AUXILIARY LIMIT SWITCH
- BC BLOWER CONTACTOR
- COMP COMPRESSOR
- CM CONDENSER MOTOR
- CC COMPRESSION CONTACTOR
- EM EVAPORATOR MOTOR
- F FUSE
- FC FAN CAPACITOR
- FS FLAME SENSOR
- GND EQUIPMENT GROUND
- GV GAS VALVE
- HPS HIGH PRESSURE SWITCH
- IBR INDOOR BLOWER RELAY
- IIC INTEGRATED IGNITION CONTROL
- IGN IGNITOR
- LPS LOW PRESSURE SWITCH
- LS LIMIT SWITCH
- PLF FEMALE PLUG/CONNECTOR
- PS PRESSURE SWITCH
- RS ROLLOUT SWITCH
- TB1 TERMINAL BLOCK (24V SIGNAL)
- TR TRANSFORMER
- VM VENT MOTOR
- VMR VENT MOTOR RELAY

NOTES

- REPLACEMENT WIRE MUST BE THE SAME SIZE AND TYPE OF INSULATION AS ORIGINAL. (USE COPPER CONDUCTOR ONLY).
- ACCESSORY ECONOMIZER PLUG ADJACENT TO BLOWER HOUSING IN RETURN AIR COMPARTMENT. REMOVE MALE PLUG AND ATTACH FEMALE PLUG TO THE ECONOMIZER ACCESSORY.
- L1 AND L2 ON IIC CONTROL IS 24V INPUT.
- USE COPPER CONDUCTORS ONLY.
- ++ USE NEC CLASS 2 WIRE.
- FOR TWO STAGE OPERATION REMOVE W1 TO W2 WIRE JUMPER.

FACTORY WIRING

- LINE VOLTAGE
- - - LOW VOLTAGE
- · - · - OPTIONAL
- HIGH VOLTAGE

FIELD WIRING

- HIGH VOLTAGE
- - - LOW VOLTAGE

WIRE CODE

- BK BLACK
- BL BLUE
- BR BROWN
- GR GREEN
- OR ORANGE
- PK PINK
- PU PURPLE
- RD RED
- WH WHITE
- YL YELLOW
- YL/PK YELLOW WITH PINK STRIP
- BL/PK BLUE WITH PINK STRIP

THERMOSTAT FIELD WIRING ++

NO ECONOMIZER

- W1 - W1
- W2 - W2
- W3 - W3
- W4 - W4
- W5 - W5
- W6 - W6
- W7 - W7
- W8 - W8
- W9 - W9
- W10 - W10
- W11 - W11
- W12 - W12
- W13 - W13
- W14 - W14
- W15 - W15
- W16 - W16
- W17 - W17
- W18 - W18
- W19 - W19
- W20 - W20
- W21 - W21
- W22 - W22
- W23 - W23
- W24 - W24
- W25 - W25
- W26 - W26
- W27 - W27
- W28 - W28
- W29 - W29
- W30 - W30
- W31 - W31
- W32 - W32
- W33 - W33
- W34 - W34
- W35 - W35
- W36 - W36
- W37 - W37
- W38 - W38
- W39 - W39
- W40 - W40
- W41 - W41
- W42 - W42
- W43 - W43
- W44 - W44
- W45 - W45
- W46 - W46
- W47 - W47
- W48 - W48
- W49 - W49
- W50 - W50
- W51 - W51
- W52 - W52
- W53 - W53
- W54 - W54
- W55 - W55
- W56 - W56
- W57 - W57
- W58 - W58
- W59 - W59
- W60 - W60
- W61 - W61
- W62 - W62
- W63 - W63
- W64 - W64
- W65 - W65
- W66 - W66
- W67 - W67
- W68 - W68
- W69 - W69
- W70 - W70
- W71 - W71
- W72 - W72
- W73 - W73
- W74 - W74
- W75 - W75
- W76 - W76
- W77 - W77
- W78 - W78
- W79 - W79
- W80 - W80
- W81 - W81
- W82 - W82
- W83 - W83
- W84 - W84
- W85 - W85
- W86 - W86
- W87 - W87
- W88 - W88
- W89 - W89
- W90 - W90
- W91 - W91
- W92 - W92
- W93 - W93
- W94 - W94
- W95 - W95
- W96 - W96
- W97 - W97
- W98 - W98
- W99 - W99
- W100 - W100

WITH ECONOMIZER OPTION

- W1 - W1
- W2 - W2
- W3 - W3
- W4 - W4
- W5 - W5
- W6 - W6
- W7 - W7
- W8 - W8
- W9 - W9
- W10 - W10
- W11 - W11
- W12 - W12
- W13 - W13
- W14 - W14
- W15 - W15
- W16 - W16
- W17 - W17
- W18 - W18
- W19 - W19
- W20 - W20
- W21 - W21
- W22 - W22
- W23 - W23
- W24 - W24
- W25 - W25
- W26 - W26
- W27 - W27
- W28 - W28
- W29 - W29
- W30 - W30
- W31 - W31
- W32 - W32
- W33 - W33
- W34 - W34
- W35 - W35
- W36 - W36
- W37 - W37
- W38 - W38
- W39 - W39
- W40 - W40
- W41 - W41
- W42 - W42
- W43 - W43
- W44 - W44
- W45 - W45
- W46 - W46
- W47 - W47
- W48 - W48
- W49 - W49
- W50 - W50
- W51 - W51
- W52 - W52
- W53 - W53
- W54 - W54
- W55 - W55
- W56 - W56
- W57 - W57
- W58 - W58
- W59 - W59
- W60 - W60
- W61 - W61
- W62 - W62
- W63 - W63
- W64 - W64
- W65 - W65
- W66 - W66
- W67 - W67
- W68 - W68
- W69 - W69
- W70 - W70
- W71 - W71
- W72 - W72
- W73 - W73
- W74 - W74
- W75 - W75
- W76 - W76
- W77 - W77
- W78 - W78
- W79 - W79
- W80 - W80
- W81 - W81
- W82 - W82
- W83 - W83
- W84 - W84
- W85 - W85
- W86 - W86
- W87 - W87
- W88 - W88
- W89 - W89
- W90 - W90
- W91 - W91
- W92 - W92
- W93 - W93
- W94 - W94
- W95 - W95
- W96 - W96
- W97 - W97
- W98 - W98
- W99 - W99
- W100 - W100

INSTALLER/SERVICEMAN

THE STATUS LIGHT ON THE FURNACE CONTROL MAY BE USED AS A GUIDE TO TROUBLESHOOTING THIS APPLIANCE. STATUS LIGHT CODES ARE AS FOLLOWS:

STATUS LIGHT	EQUIPMENT STATUS	CHECK
ON	NORMAL OPERATION	
OFF	NO POWER OR INTERNAL CONTROL	CHECK WIRING POWER CHECK FUSE ON CONTROL REPLACE CONTROL
1 BLINK	IGNITION FAILURE	GAS FLOW GAS PRESSURE GAS VALVE FLAME SENSOR
	OPEN ROLLOUT SWITCH	FLAME ROLLOUT FLAME ROLLOUT AUX LIMIT OPEN
2 BLINKS	PRESSURE SWITCH OPEN	CHECK
3 BLINKS	PRESSURE SWITCH CLOSED	CHECK
4 BLINKS	OPEN LIMIT SWITCH	PRESSURE SWITCH
5 BLINKS	FALSE FLAME SENSED	PRESSURE SWITCH MAIN LIMIT OPEN
6 BLINKS	COMPRESSOR OUTPUT DELAY	BAD SWIRL STICKING GAS VALVE 3 MIN COMP ANTICYCLE TIMER

460-575/3/60 0140L00551 REV B

WARNING

High Voltage: Disconnect all power before servicing or installing this unit. Multiple power sources may be present. Failure to do so may cause property damage, personal injury, or death.

Wiring is subject to change. Always refer to the wiring diagram or the unit for the most up-to-date wiring.

ACCESSORIES

ITEM #	DESCRIPTION	FITS MODEL SIZES	FIELD-INSTALLED	FACTORY-INSTALLED
14CURB90150	14" Roof Curb	7½-12½ tons	✓	
25FD90150	25% Manual Fresh Air Damper	7½-12½ tons	✓	
25MFD90150	25% Motorized Fresh Air Damper	7½-12½ tons	✓	
DNBBS90150	Burglar Bar Sleeves: includes Supply & Return	7½-12½ tons	✓	
CDK120	Concentric Duct Kit	10 tons	✓	
CDK150	Concentric Duct Kit	12½ tons	✓	
CDK90102	Concentric Duct Kit	7½-8½ tons	✓	
HailGD02	Condenser Coil Hail Guard	7½-10 tons	✓	✓
HailGD05	Condenser Coil Hail Guard	12½ tons	✓	✓
	Convenience Outlet: Powered			✓
	Convenience Outlet: Non Powered			✓
DNECONGS90120	Downflow Economizer	7½-10 tons	✓	✓
DNECONGS150	Downflow Economizer	12½ tons	✓	✓
DNSQRRND90	Downflow Square-to-Round Adapter 20" Round	7½ tons	✓	
	Electric Heat Kits		✓	✓
HAKT36300	High-Altitude Kit	All Models	✓	
HSKT090	High-Static Kit for 8½-ton CPGAA (230/460v)	7½-8½ tons	✓	✓
HSKT120	High-Static Kit for CPGAA (230/460v)	10 tons	✓	✓
HSKT150	High-Static Kit for CPGAA (230/460v)	12½ tons	✓	✓
HSKT090G	High-Static Kit for CPGAA & CPGBA (230/460v)	7½ tons	✓	✓
BRD3672	Horizontal Barometric Relief Damper (two required)	7½-12½ tons	✓	
HZECONGS90150	Horizontal Economizer	7½-12½ tons	✓	
GHRC-1	Hurricane Restraint Clip	All Models	✓	
LAKT03	Low-Ambient Kit for units with serial numbers 0909 and above	7½ - 12½ tons	✓	✓
LAKT02	Low-Ambient Kit for units with serial number below 0909	7½ - 12½ tons	✓	✓
LPKT36150	LP Conversion Kit	7½-12½ tons	✓	✓
PE901502	Power Exhaust 208/230 Volt	7½-12½ tons	✓	
PE901504	Power Exhaust 460 Volt	7½-12½ tons	✓	
	Smoke Detector		✓	
	Stainless Steel Heat Exchanger (Type 409)			✓
	UltraGold Condenser Coil			✓

NOTES

NOTES



Goodman Manufacturing Company, L.P. reserves the right to discontinue, or change at any time, specifications or designs without notice or without incurring obligations. © 2010 • Goodman Manufacturing Company, L.P. • Houston, Texas • Printed in the USA.

