

SPECIFICATIONS

GENERAL

Greenspec Listed Remotetype, electric refrigerated, water chiller unit. Chilling capacity of 8.0 gallons per hour of 50°F drinking water, based upon 80°F inlet water and 90°F ambient.

Compact, highly efficient water chiller units are designed for use with any drinking fountain. Also connects to a bubbler, glass filler or cold water dispenser. Converts a fountain into a water cooler. Installs directly under fountain or other application, or may be located in a service area to serve a remote outlet (within 15 feet recommended).

NO LEAD DESIGN

THIS WATER CHILLER COMPLIES WITH THE LEAD FREE DEFINITION IN THE SAFE DRINKING WATER ACT OF 1986 AND LEAD CONTAMINATION CONTROL ACT OF 1988.

Elkay Water Chillers are manufactured with a waterway system utilizing copper components and completely lead-free materials. These waterways have no lead because all lead-containing materials, such as leaded brass, have been removed. All joints are brazed using silver solder only. No lead solder is permitted.

CAPACITIES CHART

Model Number	Base Rate	*GPH of 50°F Drinking Water				Rated Watts	Full Load Amps	Ship. Wt. Lbs.
		Room Temperature °F						
		70°F	80°F	90°F	100°F			
ECH8GRN	8.0	9.7	8.8	8.0	7.2	260	2.8	47

*Based on 80°F inlet water temperature.

Rated watts shown are based on operational (run) time, in compliance with A.R.I. Standard 1010 conditions. Specific applications will determine the actual watts consumed per hour. Watts consumed will be based on number of people served per hour (usage), ambient temperatures, and inlet water temperature. Multiple outlet capacities. Service to 2 stations.

COOLING SYSTEM

Motor Compressor: High-efficiency, hermetically sealed, reciprocating type, 1/5HP, 115VAC, 60Hz single phase. Sealed-in lifetime oil supply.

Condenser: Fan cooled, copper tube with aluminum fan motor is permanently lubricated.

Cooling Unit: Combination tube-tank type. Tube portion is continuous coil of copper tubing. Tank is copper, tinned and insulated with EPS foam.

Refrigerant Control: Refrigerant HFC-134a is controlled by accurately calibrated capillary tube for positively trouble-free operation.

Temperature Control: Enclosed adjustable thermostat is factory preset. Requires no adjustment other than for altitude requirements.

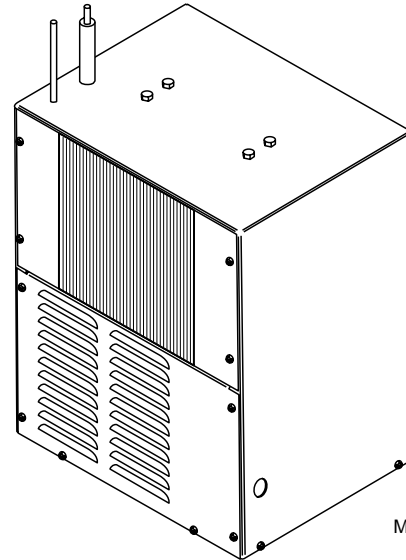

Model ECH8GRN

CONSTRUCTION

Cabinet: Rust-rust resistant galvanized steel

Drain Plug: This chiller is provided with a plastic drain plug which incorporates an o-ring seal. This fitting is designed for potable water applications and should be replaced with a suitable fitting if chiller is used with more aggressive liquids.

5 YEAR LIMITED WARRANTY on the refrigeration system of the unit. Electrical components and water system are warranted for 12 months from date of installation. Warranty pertains to drinking water applications only. Non-drinking water applications are not covered under warranty. Sample certifications available upon request.

STANDARDS



Elkay Electric Air Cooled Water Coolers are listed by Underwriters Laboratories Inc. and comply with both Canadian and U.S. requirements

These units comply with A.R.I. Standard 1010

This cooler is certified by WQA to lead-free compliance including NSF/ANSI 61-ANNEX G, AB 1953.

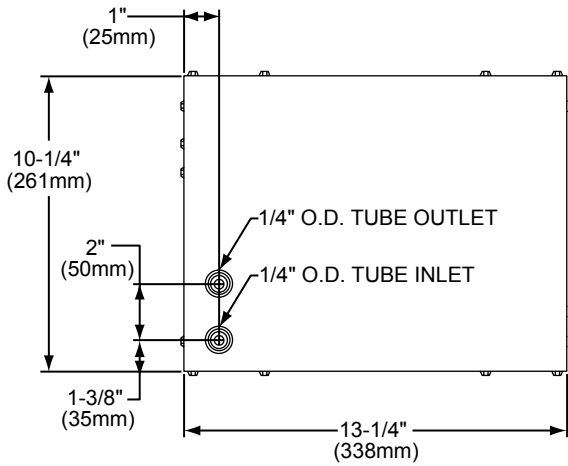

TOP VIEW

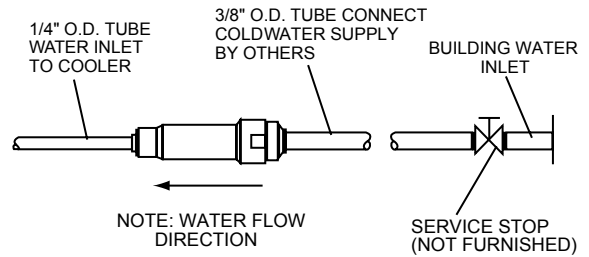

OPERATION OF QUICK CONNECT FITTINGS

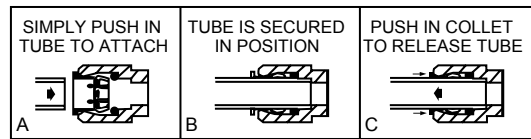

PUSHING TUBE IN BEFORE PULLING IT OUT HELPS TO RELEASE TUBE

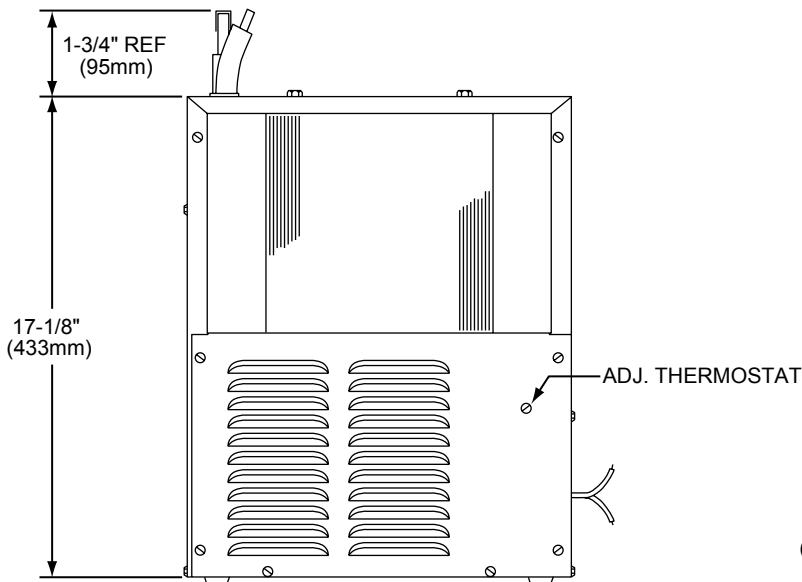

FRONT VIEW

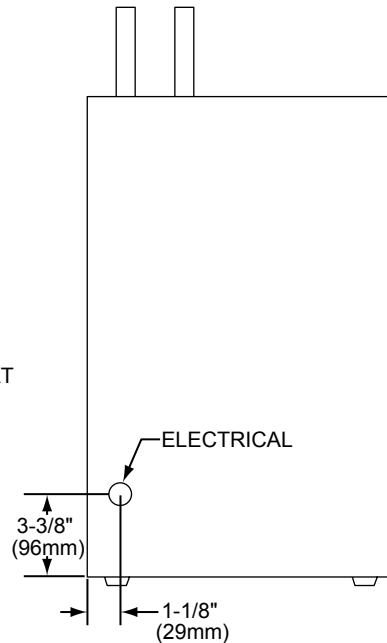

SIDE VIEW

NOTE: When mounting unit in an open area, to insure proper ventilation, maintain a 4" (102mm) clearance from cabinet louvers on each side of cooler. When mounting unit in a cavity or behind a wall, maintain minimum space of 4" (102mm) on each side, 4" (102mm) on the top and a depth of 12" (305mm).