

Submitted Model No.: \_\_\_\_\_

Specific Features: \_\_\_\_\_

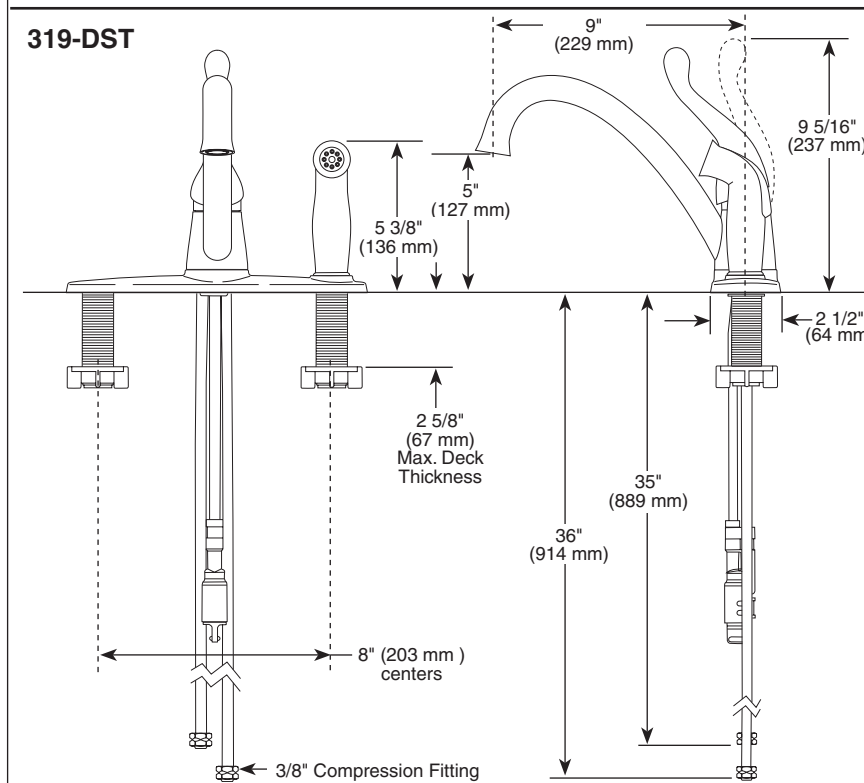
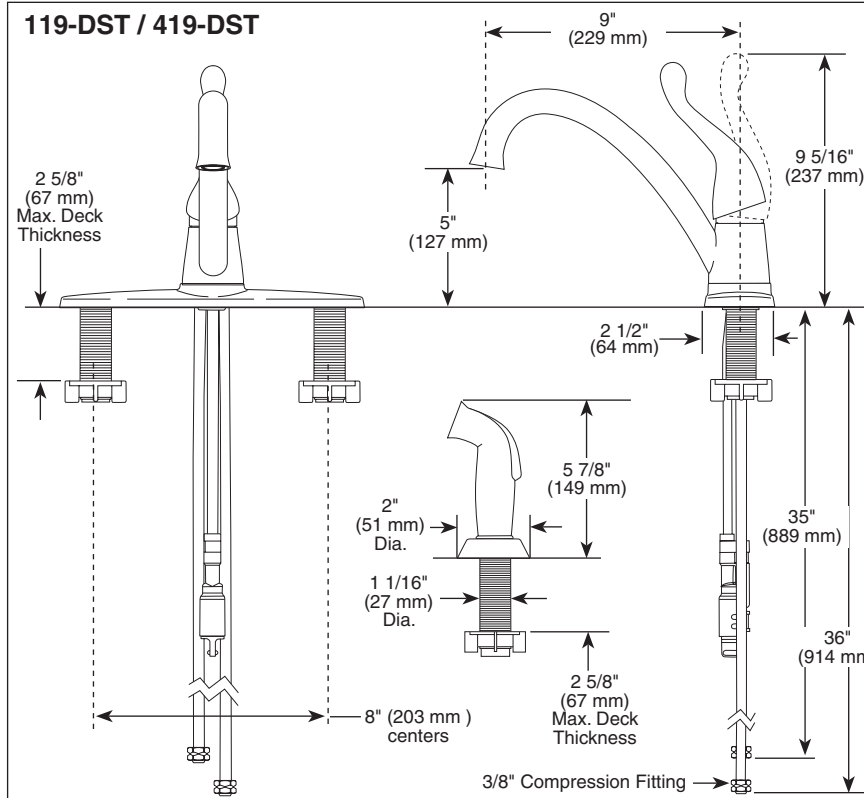

## KITCHEN FAUCETS

- Talbott™ Series
- Single Handle Deck Mount
- 3 and 4 Hole Sink Applications
- DIAMOND™ Seal Technology
- Integrated Supply Tubes
- Quick Snap® Vegetable Sprayer Hose Installation on Models 319 and 419 Series

### STANDARD SPECIFICATIONS:

- 9" (229 mm) long spout swings 180°.
- Lever handle shall return to neutral position when faucet is turned off.
- Control mechanism shall be the diamond coated ceramic cartridge.
- Red/blue graphics on handle button to indicate hot/cold temperature
- Models 319 and 419 series with spray attachment have anti-siphon device as integral part of faucet.
- Quick Snap® vegetable sprayer hose with matching finish sprayhead on models 319 and 419 series - 45" (1143mm) long hose.
- 3/8" O.D. straight, staggered pex supply tubes- 35" (889 mm) and 36" (914 mm) long.
- Standard 3/8" (10 mm) compression gasket fittings.

### WARRANTY

- Lifetime Faucet and Finish Limited Warranty to the original consumer purchaser to be free from defects in material and workmanship.
- 5 Year Limited Warranty for usage in all industrial, commercial and business applications.

### COMPLIES WITH:

- ASME A112.18.1 / CSA B125.1
- Indicates ADA compliance to ICC/ANSI A117.1
- IAPMO Listed
- CSA Certified

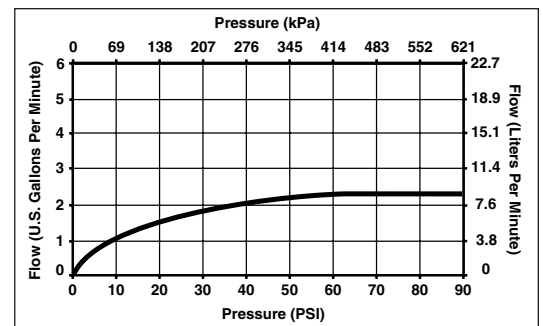

55 E. 111th Street, Indianapolis, Indiana 46280  
 395 Matheson Blvd. E., Mississauga, On L4Z 2H2  
 © 2008 Masco Corporation of Indiana

Delta reserves the right (1) to make changes in specifications and materials, and (2) to change or discontinue models, both without notice or obligation. Dimensions are for reference only. See full-line price book or [www.specselect.com](http://www.specselect.com) for finish options and product availability.  
 DSP-K-119-DST Rev. A