



COMMERCIAL PLASTIC SEATS

MODEL 383SS



- ELONGATED SEAT, CLOSED FRONT WITH COVER
- SOLID PLASTIC
- SELF-SUSTAINING, CHROME-PLATED BRASS HINGE

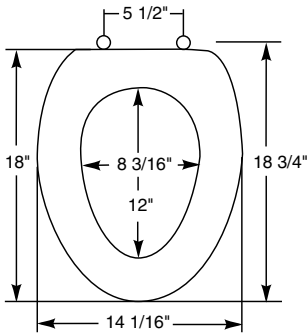

Seats shall be No. 383SS as manufactured by Church Seats. Seats shall be heavy weight and injection molded of solid plastic. Seats shall be closed front with cover for elongated bowl and feature large molded-in bumpers. Self-sustaining, chrome-plated brass hinges with 300 Series stainless steel pintles. Color to be white.

Ring thickness is 3/4"
Ring thickness including the bumper is 1-1/16"
Height of the seat with cover is 2-1/4 "

