

MODEL 126CAMT

Seats shall be 126CAMT as manufactured by Bemis Manufacturing Co. Seats shall contain DuraGuard®, an antimicrobial agent. Seats shall be injection molded of solid plastic and open front less cover to fit baby bowls. Seats shall feature large molded-in bumpers. Seats shall have STA-TITE®, Commercial Fastening System™, featuring external check hinges with 300 Series stainless steel posts and pintles that stop seat 11 degrees beyond vertical. Color to be white.

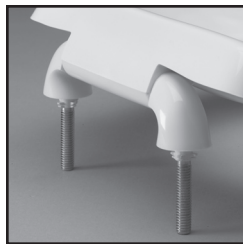

STA-TITE®, COMMERCIAL FASTENING SYSTEM™, ONE-PIECE INTEGRATED NUT AND WASHER



EXTERNAL CHECK HINGE

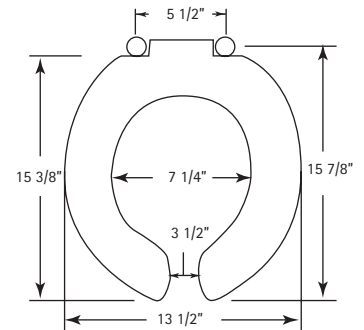

Ring thickness is 13/16"
Ring thickness including the bumper is 1-1/4"

STA-TITE®

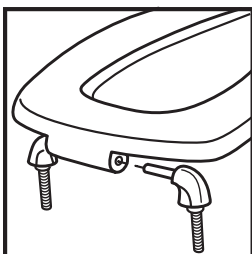

ASSEMBLE HINGES.

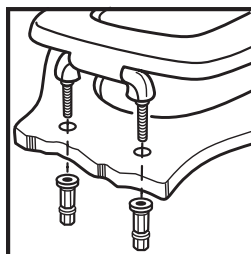

FINGER-TIGHTEN FASTENING NUTS.

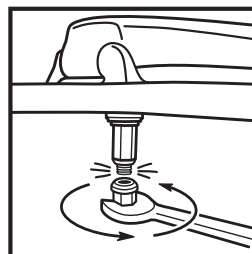

USING WRENCH, TIGHTEN UNTIL LOWER PORTION SHEARS OFF.

DuraGuard®
ANTIMICROBIAL