

MODEL 10SSCTFR

Seats shall be 10SSCTFR as manufactured by Bemis Manufacturing Co. Seats shall contain DuraGuard®, an antimicrobial agent. Seats shall contain FirePro®, a fire retardant material to meet UL-94VO flammability rating. Seats shall be heavy weight and injection molded of solid plastic. Seats shall be open front less cover for elongated bowl and feature large molded-in bumpers. Seats shall have STA-TITE®, Commercial Fastening System™, featuring external check hinges to feature 300 Series stainless steel posts that stop seat 11 degrees beyond vertical. Uses 300 Series stainless steel hardware. Color to be white.

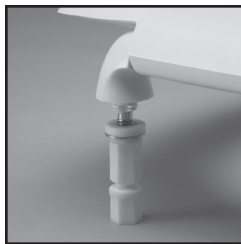

STA-TITE®, COMMERCIAL FASTENING SYSTEM™, ONE-PIECE INTEGRATED NUT AND WASHER

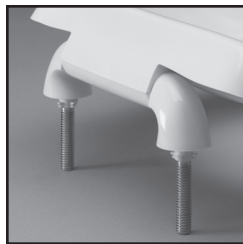

EXTERNAL CHECK HINGE

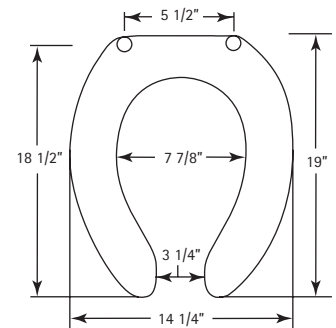

Ring thickness is 13/16"
Ring thickness including the bumper is 1

STA-TITE®

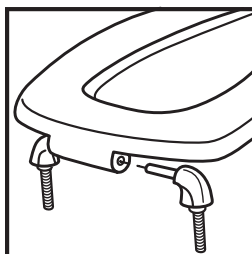

ASSEMBLE HINGES.

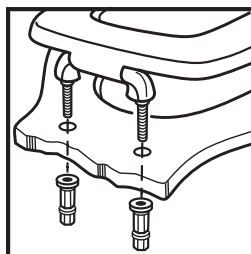

FINGER-TIGHTEN FASTENING NUTS.

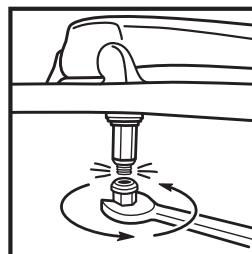

USING WRENCH, TIGHTEN UNTIL LOWER PORTION SHEARS OFF.

DuraGuard®
ANTIMICROBIAL

