

Residential Damper Atmospheric Vent Gas Water Heater



Photo is of
RG2D40S6N

The Damper FVIR Defender Safety System® Models Feature:

- **ENERGY STAR® Qualified**—Some models qualify for the September 1, 2010 minimum ENERGY STAR® EF requirement, as well as most utility rebate programs.
- **Bradford White ICON System™**—Intelligent gas control with spark to pilot ignition system eliminates the constant burning pilot. This results in savings of pilot gas during standby periods (120 V.A.C.).
 - **Enhanced Performance**—Proprietary algorithms provide enhanced First Hour Delivery ratings and tighter temperature differentials.
 - **Advanced Temperature Control System**—Microprocessor constantly monitors and controls burner operation to maintain consistent and accurate water temperature levels.
 - **Intelligent Diagnostics**—An exclusive green LED light prompts the installer during start-up and provides ten different diagnostic codes to assist in troubleshooting.
 - **Separate Immersed Thermowell**—High-strength advanced polymer composite thermowell provides isolation between electric temperature sensor and surrounding water. No need to drain the tank when removing gas valve.
- **Automatic Flue Damper**—Reduces standby heat loss, resulting in less gas consumption, higher energy factor ratings, and improved overall efficiency.
 - Ten Foot Power Cord—Included (120 VAC).
- **Advanced ScreenLok® Technology Flame Arrestor Design**—Flame arrestor is designed to prevent ignition of flammable vapor outside of the water heater.
- **Flammable Vapor Sensor**—Electronic sensor prevents burner operation if flammable vapors are detected.
- **Maintenance-Free**—No regular cleaning of air inlet openings or flame arrestor is required under normal conditions.
- **Sight Window**—Offers a view into the combustion chamber to observe the operation of the pilot and burner.
- **Factory-Installed Hydrojet® Total Performance System**—Cold water inlet sediment reducing device helps prevent sediment build-up in tank. Increases first hour delivery of hot water while minimizing temperature build-up in tank.
- **Vitraglas® Lining**—Bradford White tanks are lined with an exclusively engineered enamel formula that provides superior tank protection from the highly corrosive effects of hot water. This formula (Vitraglas®) is fused to the steel surface by firing at a temperature of over 1600°F (871°C).
- **Non-CFC Foam Insulation**—Covers the side and top, reducing the amount of heat loss. This results in less energy consumption, improved operation efficiencies, and jacket rigidity.
- **Pedestal Base.**
- **Water Connections**—3/4" NPT factory-installed true dielectric fittings.
- **Factory-Installed Heat Traps**—Design incorporates a flexible disk that reduces heat loss in piping and eliminates the potential for noise generation.
- **Protective Magnesium Anode Rod.**
- **3x4 "Snap Lock" Draft Diverter**—Allows either 3" or 4" vent connections.
- **T&P Relief Valve**—Installed.
- **Low Restriction Brass Drain Valve**—Durable tamper-proof design.

FEATURING:



6 or 10-Year Limited Tank Warranties / 6 or 10-Year Limited Warranty on Component Parts.

For more information on warranty, please visit www.bradfordwhite.com

For products installed in USA, Canada and Puerto Rico. Some states do not allow limitations on warranties. See complete copy of the warranty included with the heater.

Residential Atmospheric Vent Gas Water Heater

Damper Models

NATURAL GAS AND LIQUID PROPANE GAS

Meet or exceed ASHRAE 90.1b (current standard) C.E.C. Listed
80% Recovery Efficiency

Model Number	Capacity				1st Hour Rating (Gal.)	Energy Factor	Recovery* 90°F Rise				A Floor to Flue Conn. in.	B Jacket Dia. in.	C Vent Size in.	D Floor to T&P Conn. in.	E Floor to Gas Conn. in.	F Floor to Top of Heater in.	G Floor to Water Conn. in.	H Depth in.	J C/L of Water Conn. in.	Approx. Shipping Weight lbs.
	U.S. Gal.	Imp. Gal.	Nat. BTU/Hr. Input	LP BTU/Hr. Input			Nat. U.S. GPH	Imp. U.S. GPH	U.S. GPH	LP GPH										
RG1D30T6N	30	25	32,000	31,000	58	0.65	34	28	33	28	63	16	3 x 4	49 ⁷ / ₈	13	56 ¹ / ₄	57	20 ³ / ₄	8	116
RG1D40S6N	40	35	40,000	38,000	74	0.62	43	36	41	34	57 ⁷ / ₈	20	3 x 4	41	13	48	49 ¹ / ₈	24 ³ / ₄	8	147
RG1D40T6N	40	35	40,000	38,000	76	0.62	43	36	41	34	63 ³ / ₈	18	3 x 4	50 ¹ / ₈	13	56 ⁹ / ₁₆	57 ³ / ₄	22 ³ / ₄	8	134
RG1D50T6N	50	42	40,000	38,000	89	0.60	43	36	41	34	63 ³ / ₈	20	3 x 4	49 ⁷ / ₈	13	56 ⁹ / ₁₆	57 ³ / ₄	24 ³ / ₄	8	160
★ RG2D40S6N	40	35	38,000	38,000	72	0.67	41	34	41	34	54 ¹ / ₂	22	3 x 4	40 ⁷ / ₈	11 ³ / ₄	47 ¹¹ / ₁₆	48 ⁷ / ₈	26 ¹ / ₈	11	155
★ RG2D50S6N	50	42	40,000	40,000	86	0.67	43	36	43	36	63 ¹ / ₂	22	3 x 4	49 ⁷ / ₈	11 ³ / ₄	56 ¹ / ₂	58	26 ¹ / ₈	11	174

Model Number	Capacity				1st Hour Rating (Liters)	Energy Factor	Recovery* 50°C Rise		A Floor to Flue Conn. mm.	B Jacket Dia. mm.	C Vent Size mm.	D Floor to T&P Conn. mm.	E Floor to Gas Conn. mm.	F Floor to Top of Heater mm.	G Floor to Water Conn. mm.	H Depth mm.	J C/L of Water Conn. mm.	Approx. Shipping Weight kg.
	Liters		Nat. kW Input	LP kW Input			Nat. Liters/Hour	LP Liters/Hour										
RG1D30T6N	114		9.4	9.1	220	0.65	129	125	1600	406	76x102	1267	330	1429	1448	527	203	53
RG1D40S6N	151		11.7	11.1	280	0.62	163	155	1470	508	76x102	1041	330	1219	1248	629	203	67
RG1D40T6N	151		11.7	11.1	288	0.62	163	155	1610	457	76x102	1273	330	1437	1467	578	203	61
RG1D50T6N	189		11.7	11.1	337	0.60	163	155	1610	508	76x102	1267	330	1437	1467	629	203	73
★ RG2D40S6N	151		11.1	11.1	273	0.67	155	155	1384	559	76x102	1038	298	1211	1241	664	279	70
★ RG2D50S6N	189		11.7	11.7	326	0.67	163	163	1613	559	76x102	1267	298	1435	1473	664	279	79

Propane models feature a Titanium Stainless Steel propane burner. For Propane (LP) models change suffix "N" to "X".

For 10 year models, change suffix from "6" to "10".

*Based on manufacturer's rated recovery efficiency.

120V, 60Hz. 12 Amps.

Energy Factor and First Hour Rating is based on the latest AHRI directory listings.

★ = ENERGY STAR® Qualified.



• Models feature optional top T&P location and must be specified when ordering.

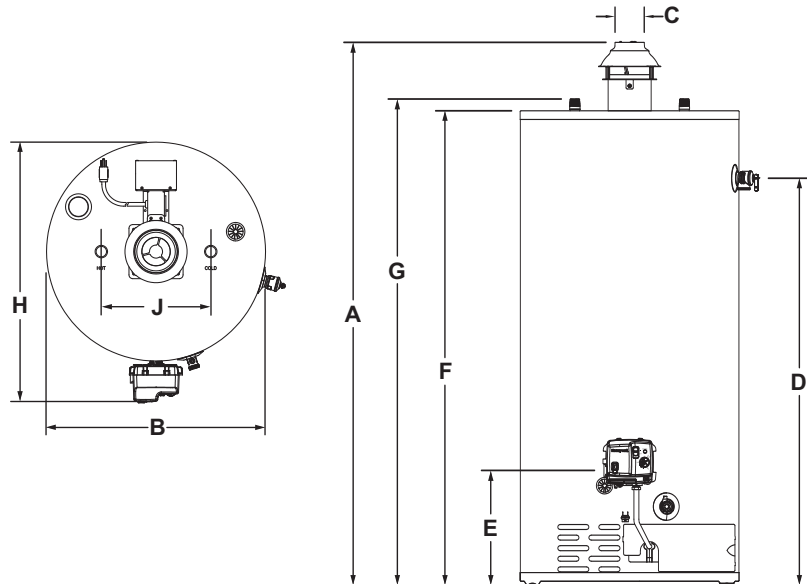

General:

All gas water heaters are certified at 300 PSI test pressure (2068 kPa) and 150 PSI working pressure (1034 kPa). All potable water connections are 3/4" NPT (19mm). All models design-certified by CSA International (formerly AGA/CGA), ANSI Z-21.10.1 and peak performance rated.

Dimensions and specifications subject to change without notice in accordance with our policy of continuous product improvement.

Suitable for Water (Potable) Heating and Space Heating.

Toxic chemicals, such as those used for boiler treatment, shall NEVER be introduced into the potable side of this system. The potable side may NEVER be connected to any existing heating system or component(s) previously used with a non-potable water heating appliance.



Ambler, PA

For U.S. and Canada field service, contact your professional installer or local Bradford White sales representative.

Sales 800-523-2931 • Fax 215-641-1670 / Technical Support 800-334-3393 • Fax 269-795-1089 • Warranty 800-531-2111 • Fax 269-795-1089

International: Telephone 215-641-9400 • Telefax 215-641-9750 / www.bradfordwhite.com



BRADFORD WHITE-CANADA INC. Sales / Technical Support 866-690-0961 / 905-238-0100 • Fax 905-238-0105 / www.bradfordwhite.com

Built to be the Best™

©2015, Bradford White Corporation. All rights reserved.