

## Commercial AERO<sup>®</sup> Series Energy Saver Oil-Powered Water Heater



Photo is of  
CF-70-3

### AERO<sup>®</sup> Series Models Feature:

- **High Recovery Rates**—Oil heats water 3 to 4 times faster than other methods. These models are designed to ensure a constant supply of hot water provided the draw-off rate is within the recovery capacity of the unit.
- **Installation**—Occupies relatively little floor space and does not require a separate fuel oil storage tank when used in oil-heated residence or commercial building.
- **Factory Installed Hydrojet<sup>®</sup> Total Performance System**—Cold water inlet sediment reduction device helps minimize sediment build up in tank. Increases the efficiency and delivery of hot water while minimizing temperature build up at top of tank (CF-70 model only).
- **Vitraglas<sup>®</sup> Lining**—Bradford White water heater tanks are protected from the corrosive effects of hot water by an exclusive ceramic porcelain-like coating. The Bradford White high silica Vitraglas<sup>®</sup> lining provides a tough interior surface for our water heater tanks.
- **Controls**—Dual immersion aquastat (supplied with burner) for precise, easy water temperature regulation and safety.
- **Beckett Burners**—All burners are 120V, 1-stage with multiple firing rates (see reverse side for part numbers). Carlin and Riello are optional burners, but not available through Bradford White.
- **New Beckett Burners are Compatible with Biofuel**—Up to B5 (5% Biofuel) can be used with water heater, provided the Biofuel meets ASTM D6751.
- **1" Non-CFC Foam Insulation**—Surrounds the tank surface, saving energy by retarding loss of heat (Center Flue model only).
- **Fiberglass Insulation**—High density fiberglass insulation provides a thick blanket around tank and combustion chamber for more heat retention and maximum fuel efficiency (Rear Flue model only).
- **Water Connections**—1" NPT factory installed dielectric waterway fittings extend water heater life and eases installation (RF-70 has 1¼" water connections).
- **Two Protective Magnesium Anode Rods**—Provide added protection against corrosion for long trouble-free service (Rear Flue models have one Magnesium Anode Rod).
- **Flexible Stainless Steel Flue Baffle**—Maximizes the amount of heat absorbed by the tank and reduces heat loss during standby periods. Hinged for low ceiling removal and cleaning (CF-70 model only).
- **Steel Tank**—Heavy gauge steel automatically formed, rolled and welded.
- **Ceramic Fiber Combustion Chamber**—Concentrates the flame for a smaller, hotter fire and faster transfer of maximum heat.
- **T&P Relief Valve**—Provided with the RF-70 model and factory installed on the CF-70 model.
- **Brass Drain Valve.**
- **Certified by CSA International (formerly AGA and CGA).**



### 3-Year Limited Tank Warranties / 1-Year Limited Warranty on Parts and Burner.

For more information on warranty, please visit [www.bradfordwhite.com](http://www.bradfordwhite.com)

For products installed in USA, Canada and Puerto Rico. Some states do not allow limitations on warranties. See complete copy of the warranty included with the heater.

## Energy Saver Models

Meet or exceed ASHRAE 90.1b (current standard).  
Recovery Efficiency ranging up to 78%

Model Number	Capacity		U.S. GPH Firing Rate	Recovery at 100°F Rise*		A	B	C	D	E	F	G	H	J	K	Approx. Shipping Weight lbs.	
	U.S. Gal.	Imp. Gal.		U.S. GPH	Imp. GPH	Floor to Flue Conn.	Jacket Dia.	Flue Size	Floor to T&P Conn.	Floor to Burner Top	Floor to Cold Water Conn.	Floor to Hot Water Conn.	Floor to Heater Top	Floor to Aquastat	Depth		
CF-70-3	70	58	119	0.85	114	95	65 <sup>15/32</sup>	24	6 <sup>1/2</sup>	56 <sup>15/32</sup>	11 <sup>13/16</sup>	64 <sup>3/8</sup>	64 <sup>3/8</sup>	63 <sup>7/16</sup>	32 <sup>31/32</sup>	30 <sup>9/16</sup>	290
RF-70-3	70	58	210/245	1.50/1.75	203/237	170/198	63 <sup>11/16</sup>	28 <sup>1/2</sup>	8	64	12 <sup>3/16</sup>	20 <sup>7/8</sup>	64	72 <sup>1/16</sup>	38 <sup>1/8</sup>	39 <sup>7/16</sup>	410

Model Number	Capacity		Recovery at 56°C Rise*	A	B	C	D	E	F	G	H	J	K	Approx. Shipping Weight kg.
	Liters	kW Input		Liters/Hour	Floor to Flue Conn. mm.	Jacket Dia. mm.	Flue Size mm.	Floor to T&P Conn. mm.	Floor to Burner Top mm.	Floor to Cold Water Conn. mm.	Floor to Hot Water Conn. mm.	Floor to Heater Top mm.	Floor to Aquastat mm.	
CF-70-3	265	34.8	431	1662	610	152	1434	300	1635	1635	1611	837	776	132
RF-70-3	265	61.5/71.8	768/897	1617	724	203	1625	310	530	1636	1833	968	1001	186

\*Based on manufacturers rated recovery efficiency.

CF = Center Flue.

RF = Rear Flue.

†MBTUH = Thousand Btu's/Hr.

Model Number	Part Number	Description**
CF-70	228-44392-05	Beckett Burner with dual Aquastat @ 0.85 GPH
RF-70	228-44392-13	Beckett Burner with dual Aquastat @ 1.50 GPH
RF-70	228-44392-15	Beckett Burner with dual Aquastat @ 1.75 GPH

\*\*All burners are 1-stage, 120V.

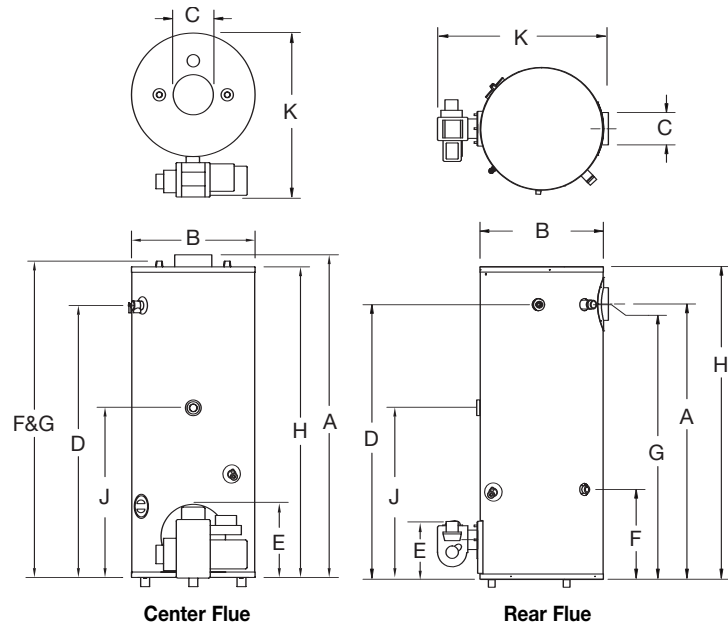

### General

All Oil-Powered water heaters are certified at 300 PSI test pressure (2068 kPa) and 150 PSI working pressure (1034 kPa).

The water connections for the CF-70 are 1" NPT (25 mm) on 11" (279 mm) centers and 1/4" (32mm) NPT front connections for the RF-70.

Approved for use with No. 2 fuel oil or lighter. Shipping weight for water heater less Oil Burner - deduct 40 lbs. (18 kg.).

All center flue water heaters meet or exceed DOE and CSA B211 energy requirements as certified by ETL. All water heaters must be installed with a temperature and pressure relief valve and on a non-combustible floor. All water heaters are approved for use with "L" vent.

**Dimensions and specifications subject to change without notice in accordance with our policy of continuous product improvement.**

**Suitable for Water (Potable) Heating and Space Heating.**

Toxic chemicals, such as those used for boiler treatment, shall NEVER be introduced into this system. This unit may NEVER be connected to any existing heating system or component(s) previously used with a non-potable water heating appliance.



For U.S. and Canada field service, contact your professional installer or local Bradford White sales representative.

Sales 800-523-2931 • Fax 215-641-1670 / Technical Support 800-334-3393 • Fax 269-795-1089 • Warranty 800-531-2111 • Fax 269-795-1089

International: Telephone 215-641-9400 • Telefax 215-641-9750 / [www.bradfordwhite.com](http://www.bradfordwhite.com)

**BRADFORD WHITE-CANADA** INC. Sales / Technical Support 866-690-0961 / 905-238-0100 • Fax 905-238-0105 / [www.bradfordwhite.com](http://www.bradfordwhite.com)

## Built to be the Best™

©2011, Bradford White Corporation. All rights reserved.