



BRADFORD WHITE®

Residential Energy Saver Gas-Upright For Manufactured Homes Direct Vent/Closed Combustion

Features:



Bradford White is ISO registered to the 9001- standard.

- All residential storage models meet or exceed efficiency requirements of the Department of Energy. ASHRAE Standard 90.1 b (current standard) and the National Appliance Energy Conservation Act of 1987 recent amendment effective January 20, 2004 which supercedes all state and local efficiency requirements.
- **1" Non-CFC foam insulation**—surrounds the tank surface, saving energy by retarding loss of heat.
- **Flue baffle**—designed to maximize the amount of heat absorbed in the lower portion of tank. Minimizes air movement in the heater during standby periods to retard heat loss up the flue.
- **Fully automatic controls**—automatic temperature selection at your fingertips. Built-in energy cut-off switch prevents abnormally high water temperature for extra safety. Built-in gas pressure regulation. Convertible control for use with LP or Natural Gas.
- **Vitraglas® lining**—Bradford White water heater tanks are protected from the corrosive effects of hot water by an exclusive ceramic porcelain-like coating. The Bradford White high silica Vitraglas® lining provides a tough interior surface for our hot water tanks.
- **Protective magnesium anode rod**—provides added protection against corrosion for long trouble-free service.
- **Heat Traps**—factory installed, minimizes heat loss through piping.
- **Water Connections**— $\frac{3}{4}$ " NPT factory installed true dielectric fittings. Extends water heater life and eases installation.
- **Closed combustion vent kit package for installation flexibility**—Includes adjustable air intake tube, roof jack and hardware. (Shipped with heater in separate box.) Must specify roof jack size when ordering. Available in 12", 18"/32", 32"/60" or 48"/95" (305mm, 457mm/813mm, 813mm/1524mm, 1219mm/2413mm) lengths.
- **Brass drain valve.**
- **T&P relief valve**—factory installed in accordance with UL.
- **Six or ten year limited warranty on steel tank**—heavy gauge steel automatically formed, rolled and welded to assure a continuous seam for glass lining.
- **Six year limited warranty on parts.**

MANUFACTURED UNDER ONE OR MORE OF THE FOLLOWING U.S. PATENTS:
5,954,492; 5,761,379; 5,943,984; 5,081,696; 5,988,117; 6,142,216; 5,199,385;
6,684,821; 5,574,822; 5,372,185; 5,485,879; 5,277,171; (B1)5,341,770; 5,660,165;
5,596,952; 5,682,666; 4,904,428; 5,023,031; 5,000,893; 4,669,448; 4,829,983;
4,808,356; 5,115,767; 5,092,519; 5,052,346; 4,416,222; 4,628,184; 4,861,968;
4,672,919; Re. 34,534. OTHER U.S. AND FOREIGN PATENT APPLICATIONS
PENDING. CURRENT CANADIAN PATENTS: 1,272,914; 1,280,043; 1,289,832;
2,045,862; 2,112,515; 2,108,186; 2,107,012.



Residential Energy Saver Gas-Upright

FOR MANUFACTURED HOMES DIRECT VENT/CLOSED COMBUSTION
 Design evaluated in accordance with the H.U.D. Manufactured Home Construction and Safety Standard, Title 24 CFR, Part 3280.707 (d)(2) for energy efficiency.
 These water heaters meet or exceed the performance standards established under ASHRAE Standard 90.1b (current standard).

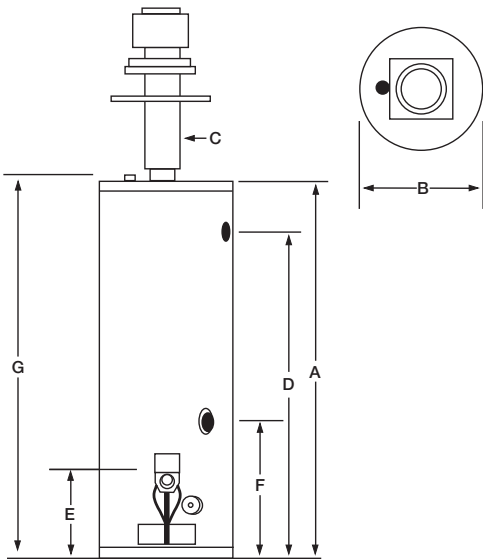

All Gas heaters equipped with specially designed aluminized-steel burner for use with energy saver models.

NEW LOW CONSUMPTION PILOT USES LESS B.T.U.'S



Adjustable air intake tube

Energy Saver Models

1" Non-CFC Foam Insulation 77% Recovery Efficiency C.E.C. Listed

	Imp. Gal. Cap.	U.S. Gal. Cap.	Liters	Nat. & LP BTU Input	KW Input	Recovery Per Hour 50°C Rise 90°F Rise		A		B		C		D		E		F		G		Approx. Shipping Weight		
						Imp. Gal.	U.S. Gal.	Liters/ Hour	Floor to Top of Heater	Jacket Dia.	Vent Size	Floor to T&P Conn.	Floor to Gas Conn.	Floor to CW Conn.	Floor to HW Conn.	Lbs.	Kg.							
M-1-MS30T6LX	26	30	114	30,000	8.8	26	31	117	57%	1457	16	406	3	76	50	1270	13%	349	22½	572	58%	1483	106	48
M-1-MS40T6LX	33	40	151	30,000	8.8	26	31	117	57%	1470	18	457	3	76	50	1270	13%	349	22½	572	58%	1485	126	55

For Natural Gas models, replace suffix "X" with "N".

This water heater is of the closed combustion type (direct venting) for mobile home applications only, where all combustion air is supplied from the outdoors through the air intake and all combusted gas products are vented directly to the outside by means of the roof jack. No draft diverter (vent hood) is required for this water heater. The U.L. listing of this water heater includes the field installation of the following components: roof jack, roof jack clamp, air intake, air intake seal and heater tie down materials. These components for field installation are shipped with the heater in a separate box and must be installed according to instructions. No other components are approved for use with the water heater. The water heater must be installed in accordance with The Federal Mobile Home Construction and Safety Standard or in the absence of such standard, The Standard for Mobile Homes (ANSI/NFPA No. 601B-1977)

General

All gas water heaters are certified at 300 PSI (2068 kPa) test pressure and 150 PSI (1034 kPa) working pressure. All water connections are ¾" (19mm) NPT. All gas connections are ½" (13mm). All models listed by U.L. For 10 year warranty change suffix number "6" to "10".

Dimensions and specifications subject to change without notice in accordance with our policy of continuous product improvement.

6-Year Limited Warranty on Component Parts

BRADFORD WHITE CORPORATION has a 6-year warranty on replaceable parts—thermostat, burner, dip tube, drain valve. These quality components are manufactured for us by industry leaders and will be replaced in the event of failure during the parts warranty period (exclusive of shipping and re-installation cost).§

6- or 10-Year Limited Tank Warranties

BRADFORD WHITE CORPORATION LIMITED WARRANTY: Protects your investment in a quality glass-lined heater. If the tank leaks for reasons of faulty materials, workmanship, or corrosion within the warranty period, the heater will be replaced with a comparable heater of our manufacture (exclusive of shipping and re-installation cost).§

§ Some states do not allow limitations on warranties. For products installed in USA, Canada and Puerto Rico. See complete copy of the warranty included with the heater.

Vitraglas® is a registered trademark of Bradford White® Corporation.
 ©2004 Bradford White Corporation. All rights reserved.

Roof Jack Kits	
Clearance	Part Number
12" (305mm)	239-37022-01
18"/32" (457mm/813mm)	239-37022-02
32"/60" (813mm/1524mm)	239-37022-03
48"/95" (1219mm/2413mm)	239-37022-04

(Includes roof jack, air intake tube, instructions)



For U.S. and Canada field service, contact your professional installer or local Bradford White sales representative.

Sales/800-523-2931
 Fax/215-641-1670

Technical Support/800-334-3393
 Fax/269-795-1089

Warranty/800-531-2111
 Fax/269-795-1089

International:
 Telephone/215-641-9400
 Telefax/215-641-9750

Fax on Demand:
 888-538-7833

www.bradfordwhite.com



Sales/Technical Support
 866-690-0961
 905-238-0100

Fax/905-238-0105

www.bradfordwhitecanada.com