

**TTW<sup>1</sup>**

## Residential Power Vent Energy Saver Gas Water Heater



Photo is of  
M-1-TW-40S6FBN

**The TTW<sup>1</sup> FVIR Defender Safety System<sup>®</sup> Models Feature:**

- **Power Vented Water Heater**—Designed for installations where atmospheric units cannot be used. Exhaust gases are vented under positive pressure directly out of the building through the roof or the wall.
- **Advanced ScreenLok<sup>®</sup> Technology Flame Arrestor Design**—Flame arrestor is designed to prevent ignition of flammable vapor outside of the water heater.
- **Flammable Vapor Sensor**—Electronic sensor prevents burner operation if flammable vapors are detected. The sensor will also prevent operation if there is ongoing flammable vapor burn inside the combustion chamber.
- **Maintenance Free**—No regular cleaning of air inlet openings or flame arrestor is required under normal conditions.
- **Sight Window**—Offers a view into the combustion chamber to observe the operation of the pilot and burner.
- **Factory installed Hydrojet<sup>®</sup> Total Performance System**—Cold water inlet sediment reducing device helps prevent sediment build up in tank. This increases first hour delivery, while minimizing temperature build up at top of tank.
- **Vitraglas<sup>®</sup> Lining**—Bradford White tanks are lined with an exclusively engineered enamel formula that provides superior tank protection from the highly corrosive effects of hot water. This formula (Vitraglas<sup>®</sup>) is fused to the steel surface by firing at a temperature of over 1600°F (871°C).
- **Powerful Blower Motor**—Our significantly quiet design has greater resistance to outside winds and the power to vent in many difficult venting situations.
- **Honeywell Self Diagnostic Electronic Gas Control**—Intelligent gas control with spark to pilot ignition system eliminates the constant burning pilot. This results in savings of pilot gas during stand by periods (120 V.A.C.).
  - **Enhanced Performance**—Proprietary algorithms provide enhanced First Hour Delivery ratings and tighter temperature differentials.
  - **Advanced Temperature Control System**—Microprocessor constantly monitors and controls burner operation to maintain accurate and consistent water temperature levels.
  - **Intelligent Diagnostics**—An exclusive green LED light prompts the installer during start-up and provides ten different diagnostic codes to assist in troubleshooting.
  - **Pilot On Indication**—Flashing green LED provides positive indication that pilot is on.
- **Compatible With Optional Accessory Packages**—Performance Package, Protection Package and Inlet Shut-Off Valve.
- **Horizontal and Vertical Venting**—With 2" or 3" PVC, ABS or CPVC (Maximum equivalent vent length on reverse side).
- **1" Non-CFC Foam Insulation**—Covers the sides and top, reducing the amount of heat loss. This results in less energy consumption, improved operation efficiencies and jacket rigidity.
- **Water Connections**—3/4"NPT factory installed true dielectric fittings.
- **Factory installed Heat Traps**—Design incorporates a flexible disk that reduces heat loss in piping and eliminates the potential for noise generation.
- **Protective Magnesium Rod.**
- **Pedestal Base.**
- **T&P Relief Valve**—Included.
- **Low Restriction Brass Drain Valve**—Durable tamper proof design.

**FEATURING:**



**6 or 10-Year Limited Tank Warranties / 6 or 10-Year Limited Warranty on Component Parts.**

For more information on warranty, please visit [www.bradfordwhite.com](http://www.bradfordwhite.com)

For products installed in USA, Canada and Puerto Rico. Some states do not allow limitations on warranties. See complete copy of the warranty included with the heater.

# Residential Power Vent Water Heater

## TTW®1 Energy Saver Models

NATURAL GAS AND LIQUID PROPANE GAS

Meet or exceed ASHRAE 90.1b (current standard) C.E.C. Listed  
80% Recovery Efficiency

Model Number	Capacity		Nat. BTU/Hr. Input	LP BTU/Hr. Input	Recovery 90°F Rise*				A Floor to Vent Conn. in.	B Jacket Dia. in.	C Vent Size in.	D Floor to T&P Conn. in.	E Floor to Gas Conn. in.	F Floor to Top of Heater in.	G Floor to Water Conn. in.	H Depth in.	Approx. Shipping Weight lbs.
	U.S. Gal.	Imp. Gal.			Nat. U.S. GPH	Imp. U.S. GPH	LP U.S. GPH	Imp. LP GPH									
M-1-TW-40S6FBN	40	33	40,000	38,000	43	36	41	34	56½	20	2	40½	11¼	46½	48	24¼	135
M-1-TW-50S6FBN	50	42	40,000	38,000	43	36	41	34	57½	22	2	40½	11¼	47½	49¼	26¼	160
M-1-TW-60T6FBN	60	51	42,000	40,000	45	38	43	36	68	22	2	50½	11¼	57½	58½	27¼	193

  

Model Number	Capacity		Nat. kW Input	LP kW Input	Recovery 50°C Rise*		A Floor to Vent Conn. mm.	B Jacket Dia. mm.	C Vent Size mm.	D Floor to T&P Conn. mm.	E Floor to Gas Conn. mm.	F Floor to Top of Heater mm.	G Floor to Water Conn. mm.	H Depth mm.	Approx. Shipping Weight kg.
	Liters				Nat. Liters/Hour	LP Liters/Hour									
M-1-TW-40S6FBN	151		11.7	11.0	163	155	1435	508	51	1030	298	1175	1220	632	75
M-1-TW-50S6FBN	190		11.7	11.0	163	155	1457	560	51	1038	298	1197	1251	679	84
M-1-TW-60T6FBN	227		12.3	11.7	170	163	1727	560	51	1292	298	1467	1486	692	88

Propane models feature a Titanium Stainless Steel propane burner. For Propane (LP) models change suffix "BN" to "SX". For 10 year models, change suffix from "6" to "10".

\*Based on manufacturer's rated recovery efficiency.

110 V.A.C. Required for Power Venting / 110 V.A.C., 60HZ, 3.1 Amperes

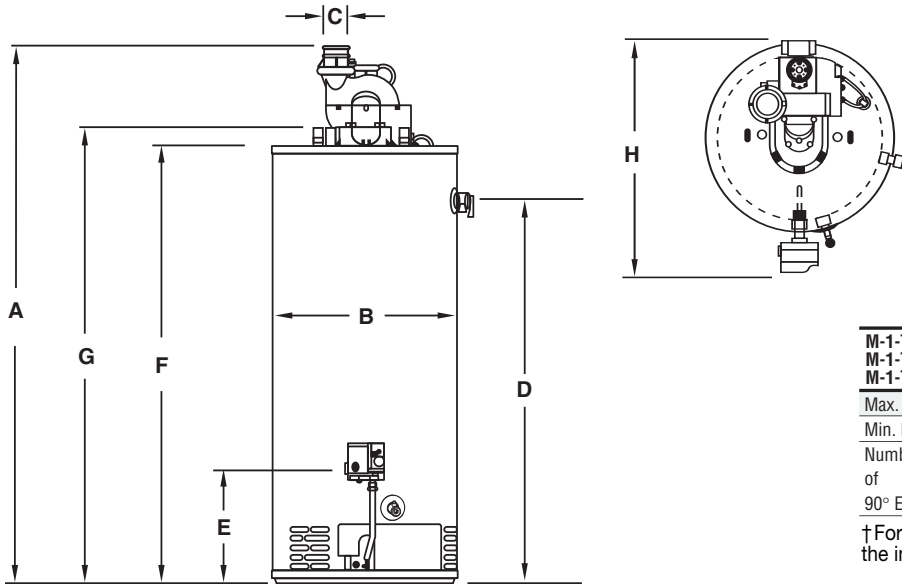

	2" Vent Pipe	3" Vent Pipe
M-1-TW40		
M-1-TW50		
M-1-TW60		
Max. Equivalent Length	†50 ft.	†120 ft.
Min. Equivalent Length	7 ft.	15 ft.
Number of 90° Elbows	1 45 ft. 2 40 ft. 3 35 ft.	115 ft. 110 ft. 105 ft.

†For high altitude installations, consult the installation instructions.

### General

All gas water heaters are certified at 300 PSI (2068 kPa) test pressure and 150 PSI (1034 kPa) working pressure.

All water connections are 3/4" NPT (19mm) on 8" (203mm) centers, all gas connections are 1/2" (13mm).

All models design certified by CSA International (formerly AGA/CGA), ANSI Z-21.10.1 and peak performance rated.

**Dimensions and specifications subject to change without notice in accordance with our policy of continuous product improvement.**

Suitable for Water (Potable) Heating and Space Heating.

Toxic chemicals, such as those used for boiler treatment, shall NEVER be introduced into this system. This unit may NEVER be connected to any existing heating system or component(s) previously used with a non-potable water heating appliance.



For U.S. and Canada field service, contact your professional installer or local Bradford White sales representative.

Sales 800-523-2931 • Fax 215-641-1670 / Technical Support 800-334-3393 • Fax 269-795-1089 • Warranty 800-531-2111 • Fax 269-795-1089

International: Telephone 215-641-9400 • Telefax 215-641-9750 / [www.bradfordwhite.com](http://www.bradfordwhite.com)

**BRADFORD WHITE-CANADA** INC. Sales / Technical Support 866-690-0961 / 905-238-0100 • Fax 905-238-0105 / [www.bradfordwhite.com](http://www.bradfordwhite.com)

**Built to be the Best™**

©2011, Bradford White Corporation. All rights reserved.