

## Commercial Flue Damper Millivolt-Powered Energy Saver Gas Water Heater



Photo is of  
DM-100T-199-3N

### The Commercial Flue Damper Models feature:

- **Automatic Flue Damper**—Reduces stand-by loss, saving gas consumption and improving overall efficiency.
- **Hand Hole Cleanout**—Allows inspection of the tank interior and facilitates the removal of sediment deposits.
- **Millivolt-Powered Control**—No external electrical source is required for operation. An adjustable thermostat can be set up to 180°F (82°C).
- **Factory Installed Hydrojet<sup>®</sup> Sediment Reduction System**—Cold water inlet sediment reducing device helps prevent sediment build up in tank. Increases first hour delivery of hot water while minimizing temperature build up in tank.
- **Vitraglas<sup>®</sup> Lining**—Bradford White tanks are lined with an exclusively engineered enamel formula that provides superior tank protection from the highly corrosive effects of hot water. This formula (Vitraglas<sup>®</sup>) is fused to the steel surface by firing at a temperature of over 1600°F (871°C).
- **Water Connections**—Factory installed true dielectric waterway fittings extend heater life and ease installation. Multiple water connection locations allow for greater installation flexibility.
- **E.C.O.**—An automatic re-set Energy Cut Off (E.C.O.) shuts off all gas in the event of an overheat condition. This automatically resets when operation conditions are back to normal.
- **Non-CFC Foam Insulation**—Covers the sides and top of tank, reducing the amount of heat loss. This results in less energy consumption, improved operation efficiencies and jacket rigidity.
- **Magnesium Anode Rods**—Provide added protection against corrosion for long trouble-free service.
- **Sanitizing Capability**—Temperature setting up to 180°F (82°C).
- **Low NOx Construction Available.**
- **T&P Relief Valve**—Installed.
- **Low Restriction Brass Drain Valve**—Durable tamper proof design.
- **NSF construction available.**
- **North Carolina Code Compliant.**
- **ASME code available on all models above 200,000 BTU/Hr.**



### 3-Year Limited Tank Warranties / 1-Year Limited Warranty on Component Parts.

For more information on warranty, please visit [www.bradfordwhite.com](http://www.bradfordwhite.com)

For products installed in USA, Canada and Puerto Rico. Some states do not allow limitations on warranties. See complete copy of the warranty included with the heater.

MANUFACTURED UNDER ONE OR MORE OF THE FOLLOWING U.S. PATENTS: 5,954,492; 5,761,379; 5,943,984; 5,081,696; 5,988,117; 6,142,216; 5,199,385; 5,574,822; 5,372,185; 5,485,879; 5,277,171; (B1)5,341,770; 5,660,165; 5,596,952; 5,682,666; 4,904,428; 5,023,031; 5,000,893; 4,669,448; 4,829,983; 4,808,356; 5,115,767; 5,092,519; 5,052,346; 4,416,222; 4,628,184; 4,861,968; 4,672,919; Re. 34,534; 7,270,087 B2. OTHER U.S. AND FOREIGN PATENT APPLICATIONS PENDING. CURRENT CANADIAN PATENTS: 1,272,914; 1,280,043; 1,289,832; 2,045,862; 2,112,515; 2,108,186; 2,107,012; 2,092,105; 2,409,271. Vitraglas<sup>®</sup> and Hydrojet<sup>®</sup> are registered trademarks of Bradford White<sup>®</sup> Corporation.

# Commercial Gas Water Heater

## Millivolt Powered Energy Saver Models

NATURAL GAS AND LIQUID PROPANE GAS

Meet or exceed ASHRAE 90.1b (current standard) C.E.C. Listed

Model Number	Capacity		Nat. BTU/Hr. Input	LP BTU/Hr. Input	1st Hour Delivery Rating at 100°F Rise	GPH Recovery at Degree Rise*			A Top Vent Height in.	B Jacket Dia. in.	C Vent Dia. in.	D Front Hot Water Conn. in.	E Floor to Gas Conn. in.	F Front Cold Water Conn. in.	H Floor to Top of Heater in.	J Floor to Top Water Conn. in.	Water Conn. in.	Gas Conn. Dia. in.	Relief Valve Open. in.	Approx. Shipping Weight (lbs.)	
	U.S. Gal.	Imp. Gal.				40°F	100°F	140°F												Std.	ASME
DM-38T-155-3N+	38	31	155,000	155,000	174	368	147	107	51	28 1/4	6	34 1/2	4 5/8	19 3/8	43	—	1 1/2	3/4	3/4	438	—
DM-75T-125-3N	75	62	125,000	125,000	174	303	121	86	72 1/4	28 1/4	5	54 1/2	4 3/4	34	65	67 1/8	1 1/2	3/4	3/4	520	—
DM-75T-160-3N	75	62	160,000	155,000	204	378	151	108	72 1/4	28 1/4	6	54 1/2	4 3/4	34	65	67 1/8	1 1/2	3/4	3/4	520	—
DM-80T-180-3N	80	67	180,000	180,000	231	436	175	124	72 3/8	28 1/4	6	56	4 3/4	19 1/2	64 1/2	66 1/4	1 1/2	3/4	3/4	540	—
DM-80T-199-3N	80	67	199,999	190,000	250	485	194	139	72 3/8	28 1/4	6	56	4 3/4	19 1/2	64 1/2	66 1/4	1 1/2	3/4	3/4	540	—
DM-80T-250-3N(A)	80	67	250,000	235,000	298	606	242	173	72 3/8	28 1/4	6	56	4 3/4	19 1/2	64 1/2	66 1/4	1 1/2	3/4	1	540	590
DM-100T-199-3N	98	82	199,999	199,999	263	485	194	139	83 3/8	28 1/4	6	67	4 3/4	19 1/2	75 1/2	77 1/4	1 1/2	3/4	3/4	610	—
DM-100T-250-3N(A)	98	82	250,000	235,000	311	606	242	173	83 3/8	28 1/4	6	67	4 3/4	19 1/2	75 1/2	77 1/4	1 1/2	3/4	1	610	690
DM-100L-199-3N	100	83	199,999	199,999	264	485	194	139	75	30 1/4	6	56 1/2	4 1/2	23 1/2	65	67	1 1/2 (RFP 2/R)	3/4	3/4	725	—
DM-100L-250-3N(A)	100	83	250,000	250,000	312	606	242	173	75	30 1/4	6	56 1/2	4 1/2	23 1/2	65	67	1 1/2 (RFP 2/R)	3/4	1	725	765
DM-100L-270-3N(A)**	100	83	270,000	—	332	655	262	187	75	30 1/4	6	56 1/2	4 1/2	23 1/2	65	67	1 1/2 (RFP 2/R)	3/4	1	725	765
DM-100S-199-3N	100	83	199,999	199,999	264	485	194	139	76 3/4	30 1/4	6	60 1/2	4 1/2	20 3/4	72 7/8	75	1 1/2 (RFP 2/R)	3/4	3/4	667	—
DM-100S-250-3N(A)	100	83	250,000	250,000	312	606	242	173	76 3/4	30 1/4	6	60 1/2	4 1/2	20 3/4	72 7/8	75	1 1/2 (RFP 2/R)	3/4	1	667	702

Model Number	Capacity		Nat. kW Input	LP kW Input	1st Hour Delivery Rating at 56°C Rise	LPH Recovery at Degree Rise*			A Top Vent Height mm.	B Jacket Dia. mm.	C Vent Dia. mm.	D Front Hot Water Conn. mm.	E Floor to Gas Conn. mm.	F Front Cold Water Conn. mm.	H Floor to Top of Heater mm.	J Floor to Top Water Conn. mm.	Water Conn. mm.	Gas Conn. Dia. mm.	Relief Valve Open. mm.	Approx. Shipping Weight (Kg.)	
	Liters					22°C	56°C	78°C												Std.	ASME
DM-38T-155-3N+	144		45.4	45.6	659	1391	556	397	1295	718	152	883	117	492	1092	—	38	19	19	199	—
DM-75T-125-3N	284		36.6	36.6	659	1147	458	326	1835	718	127	1384	121	864	1651	1705	38	19	19	236	—
DM-75T-160-3N	284		46.8	45.6	772	1431	572	409	1835	718	152	1384	121	864	1651	1705	38	19	19	236	—
DM-80T-180-3N	303		52.7	52.8	874	1650	662	469	1838	718	152	1422	121	495	1638	1683	38	19	19	245	—
DM-80T-199-3N	303		58.6	55.7	946	1836	734	526	1838	718	152	1422	121	495	1638	1683	38	19	19	245	—
DM-80T-250-3N(A)	303		73.2	68.9	1128	2294	916	655	1838	718	152	1422	121	495	1638	1683	38	19	25	245	268
DM-100T-199-3N	371		58.6	58.6	995	1836	734	526	2118	718	152	1702	121	495	1918	1962	38	19	19	277	—
DM-100T-250-3N(A)	371		73.2	68.9	1177	2294	916	655	2118	718	152	1702	121	495	1818	1962	38	19	25	277	313
DM-100L-199-3N	379		58.6	58.6	999	1836	734	526	1905	768	152	1435	114	597	1651	1702	38 (RFP 51/R)	19	19	329	—
DM-100L-250-3N(A)	379		73.2	73.3	1181	2294	916	655	1905	768	152	1435	114	597	1651	1702	38 (RFP 51/R)	19	25	329	347
DM-100L-270-3N(A)**	379		79.0	—	1257	2479	992	708	1905	768	152	1435	114	597	1651	1702	38 (RFP 51/R)	19	25	329	347
DM-100S-199-3N	379		58.6	58.6	999	1836	734	526	1949	718	152	1537	114	527	1851	1905	38 (RFP 51/R)	19	19	302	—
DM-100S-250-3N(A)	379		73.2	73.3	1181	2294	916	655	1949	718	152	1537	114	527	1851	1905	38 (RFP 51/R)	19	25	302	318

\*Recoveries and First Hour Delivery Rating are based on Thermal Efficiencies of 80%.

(A) = ASME Code Available

(F) = Front Water Connection

(R) = Rear Water Connection

(T) = Top Water Connection

† = Fiberglass Insulation

\*\* = Available in Natural Gas Only

For Propane Gas (LP) models change suffix "N" to "X".

For LowNOx compliance to meet SCAQMD requirements, place an "E" following the BTU Input identifier of the model number.

Example: DM-75T-125E-3N

# Commercial Gas Water Heater

## Water Connections

Top and Front

DM80T180, 199, 250

DM100T199, 250

DM75T125, 160

## Top Front, Rear

DM100L199, 250, 270

DM100S199, 250

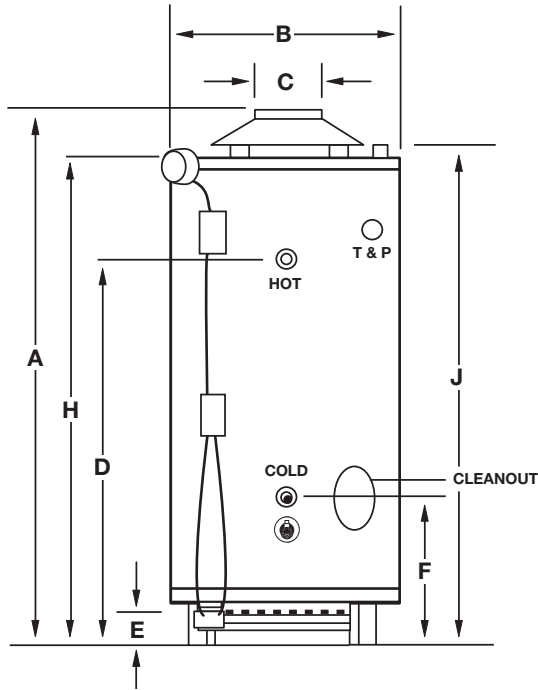

## Water Connections

Front and Rear

DM38T155

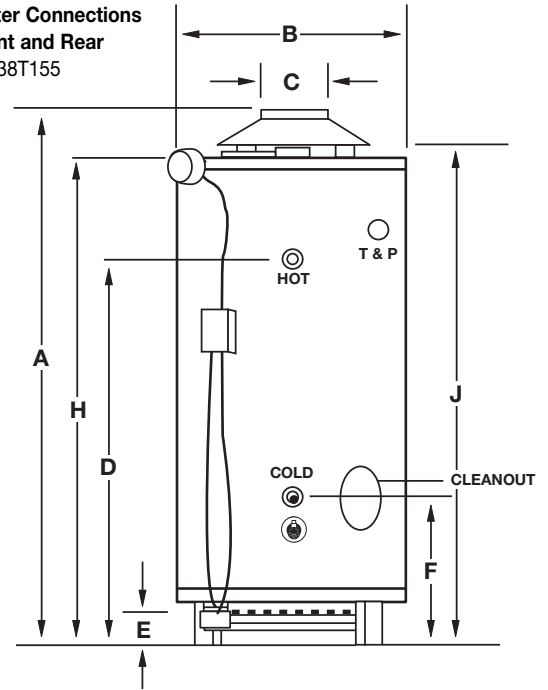

## Water Connections

Top and Front

Top Front, Rear

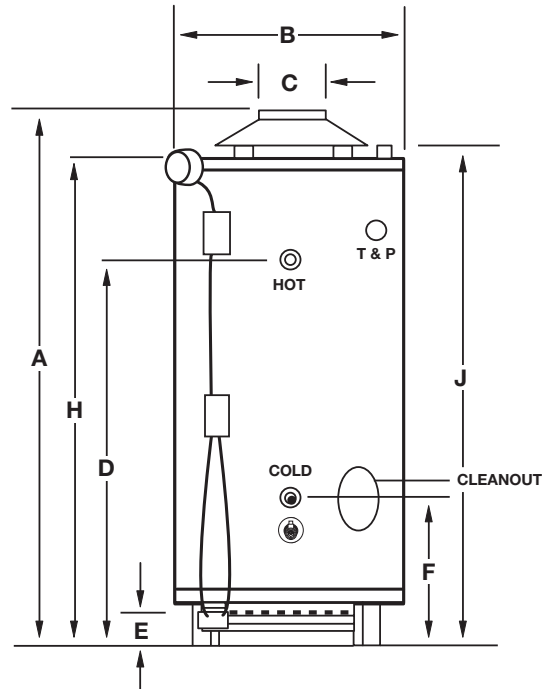

# Commercial Gas Water Heater

## Sample Specification

The water heater shall be a Bradford White model with a rated storage capacity of not less than \_\_\_\_\_ gallons (\_\_\_\_\_ liters), a minimum gas input of \_\_\_\_\_ BTU/Hr. (\_\_\_\_\_ kW), a minimum recovery of \_\_\_\_\_ GPH (\_\_\_\_\_ LPH), and a minimum First Hour Delivery of \_\_\_\_\_ Gal. (\_\_\_\_\_ liters). The tank shall be Vitraglas® lined and have a bolted hand hole cleanout. A millivolt-powered control shall be an adjustable electronic thermostat to any temperature up to 180°F (82°C) must have an automatic re-set Energy Cut-off (E.C.O), which shuts off all gas in an event of a overheat condition. The tank shall have \_\_\_\_\_ magnesium anode rods installed in separate tank head couplings. The heater shall have Non-CFC foam insulation, standing pilot, and come equipped with an ASME rated T&P relief valve, a cold water inlet Hydrojet® Sediment Reduction System, and a automatic flue damper (no electricity required). It shall be design certified by CSA International for 180°F (82°C) application, either with or without a separate storage tank, and comply with state and local codes and ordinances.

## General

All gas water heaters are certified at 300 PSI test pressure (2068 kPa) and 150 PSI working pressure (1034 kPa). All models are design certified by CSA International (formerly AGA/CGA), ANSI standard Z-21.10.3, for up to 180°F (82°C) application as an Automatic Storage Heater, and an Automatic Circulating Tank Heater. As an Automatic Storage Heater, all models are complete, self-contained water heating systems. It needs no separate storage tank, pump, wiring or elaborate piping network. When equipped with a mixing valve, it will supply 180°F (82°C) sanitizing and 140°F (60°C) general purpose hot water simultaneously. These models can be used either as a single unit or in multiples connected in series or parallel (recommended).

***Dimensions and specifications subject to change without notice in accordance with our policy of continuous product improvement.***



Ambler, PA

For U.S. and Canada field service, contact your professional installer or local Bradford White sales representative.

Sales 800-523-2931 • Fax 215-641-1670 / Technical Support 800-334-3393 • Fax 269-795-1089 • Warranty 800-531-2111 • Fax 269-795-1089

International: Telephone 215-641-9400 • Telefax 215-641-9750 / [www.bradfordwhite.com](http://www.bradfordwhite.com)

**BRADFORD WHITE-CANADA**® INC. Sales / Technical Support 866-690-0961 / 905-238-0100 • Fax 905-238-0105 / [www.bradfordwhite.com](http://www.bradfordwhite.com)

## Built to be the Best™

©2011, Bradford White Corporation. All rights reserved.