

Commercial ASME Electric Water Heaters



Photo is of
30A-36-3

The ASME Electric Models feature:

- **A.S.M.E. Code Tank Construction**—Standard.
- **Immersion Thermostats**—Immersion type for accurate temperature control from up to 180°F (82°C) with manual reset high limit control.
- **Factory Installed Hydrojet[®] Sediment Reduction System**—Cold water inlet sediment reducing device helps prevent sediment build up in the tank.
- **Vitraglas[®] Lining**—Bradford White tanks are lined with an exclusively engineered enamel formula that provides superior tank protection from the highly corrosive effects of hot water. This formula (Vitraglas[®]) is fused to the steel surface by firing at a temperature of over 1600°F (871°C).
- **Water Connections**—Factory installed true dielectric fittings extend water heater life and eases installation.
- **Elements**—screw in style. Low watt density incoloy material helps to minimize dry fire and prevents lime build up.
- **Non-CFC Foam Insulation**—Covers the sides and top of tank, reducing the amount of heat loss. This results in less energy consumption, improved operation efficiencies and jacket rigidity.
- **Protective Magnesium Anode Rod**—Provides added protection against corrosion for long trouble-free service.
- **Completely Pre-wired**—With pressure lug terminal block eliminating need for splicing or taping of wires.
- **Hand Hole Cleanout**—(20 thru 120 gallon models only).
- **T&P Relief Valve**—Installed.
- **Low Restriction Brass Drain Valve**—Durable tamper proof design.
- **NSF Construction Available on All Models.**



3 or 5-Year Limited Tank Warranties / 1-Year Limited Warranty on Component Parts.

For more information on warranty, please visit www.bradfordwhite.com

For products installed in USA, Canada and Puerto Rico. Some states do not allow limitations on warranties.

See complete copy of the warranty included with the heater.

Commercial Electric Water Heater

ASME Electric Models

Meet or exceed ASHRAE 90.1b (current standard) C.E.C. Listed

Model Number	Capacity		Max. kW Input	A Height	B Jacket Dia.	C Height to T&P Conn.	D Floor to Hot Water Outlet	E Floor to Cold Water Inlet	F Floor to Top of Control Box	Water Conn.	Approx. Shipping Weight
	U.S. Gal.	Imp. Gal.		in.	in.	in.	in.	in.	in.	in.	in.
6A-KW-3	6	5	3	17 ¹ / ₄	16	18 ¹ / ₁₆	18 ¹ / ₄	6 ¹ / ₄	17	3/4	83
12A-KW-3	12	10	9	28	16	28 ⁵ / ₁₆	29	6 ¹ / ₄	28	3/4	118
20A-KW-3	20	17	18	27 ¹ / ₂	20	28	28 ¹ / ₂	6 ¹ / ₄	27	3/4	145
30A-KW-3	30	25	36	38	20	40 ¹ / ₄	39	6 ¹ / ₄	38	3/4	180
40A-KW-3	40	33	36	48 ¹ / ₄	20	50 ¹ / ₂	49 ¹ / ₄	6 ¹ / ₄	38	3/4	220
50A-KW-3	50	42	81	47 ³ / ₄	24	50 ³ / ₈	49 ¹ / ₄	6	46 ¹ / ₂	1 ¹ / ₂	270
80A-KW-3	80	67	81	60 ¹ / ₄	26	61 ³ / ₈	61 ³ / ₄	6	46 ¹ / ₂	1 ¹ / ₂	335
120A-KW-3	119	100	81	64 ¹ / ₂	30 ¹ / ₄	66 ⁵ / ₁₆	66	6	50 ¹ / ₄	1 ¹ / ₂	430

Model Number	Capacity		Max. kW Input	A Height	B Jacket Dia.	C Height to T&P Conn.	D Floor to Hot Water Outlet	E Floor to Cold Water Inlet	F Floor to Top of Control Box	Water Conn.	Approx. Shipping Weight
	Liters			mm.	mm.	mm.	mm.	mm.	mm.	mm.	mm.
6A-KW-3	23		3	438	406	459	464	159	432	19	38
12A-KW-3	45		9	711	406	735	737	159	711	19	54
20A-KW-3	76		18	699	508	711	724	159	686	19	66
30A-KW-3	114		36	965	508	1022	991	159	965	19	82
40A-KW-3	152		36	1226	508	1283	1251	159	965	19	100
50A-KW-3	190		81	1213	610	1280	1251	152	1181	38	123
80A-KW-3	303		81	1530	661	1570	1569	152	1181	38	152
120A-KW-3	451		81	1638	766	1681	1676	152	1276	38	195

Voltage and phase must be specified when ordering. Example: 80A-18-3, 240 Volt, 3 phase.

Number of Elements (Fused Models)*

Input kW	208V Phase		240V Phase		277V Phase		380V Phase		415V Phase		480V Phase		600V Phase	
	1	3	1	3	1	3	3	3	1	3	1	3	3	3
3	1	1	1	1	1	1	1	1	1	1	1	1	1	1
6	3	3	3	3	3	3	3	3	3	3	3	3	3	3
9	3	3	3	3	3	3	3	3	3	3	3	3	3	3
12	3	3	3	3	3	3	3	3	3	3	3	3	3	3
13.5	3	3	3	3	3	3	3	3	3	3	3	3	3	3
15	3	3	3	3	3	3	3	3	3	3	3	3	3	3
18	3	3	3	3	3	3	3	3	3	3	3	3	3	3
24	4	6	4	6	4	6	4	6	4	6	4	6	6	6
27	6	6	6	6	6	6	6	6	6	6	6	6	6	6
30	6	6	6	6	6	6	6	6	6	6	6	6	6	6
36	6	6	6	6	6	6	6	6	6	6	6	6	6	6
45	9	9	9	9	9	9	9	9	9	9	9	9	9	9
54	9	9	9	9	9	9	9	9	9	9	9	9	9	9
81	9	9	9	9	9	9	9	9	9	9	9	9	9	9

Full Load Current Amperes (Fused Models)*

Input kW	208V Phase		240V Phase		277V Phase		380V Phase		400V Phase		415V Phase		480V Phase		600V Phase	
	1	3	1	3	1	3	3	3	3	3	1	3	1	3	3	3
3	14	14	13	13	11	5	8	N/A	6	6	2.8					
6	29(2)	17	25(2)	14	22(2)	9	9	8	13(2)	7	6					
9	43	25	38	22	33	14	13	13	19	11	9					
12	58	33	50	29	43(2)	18	17	17	25(2)	14	12					
13.5	65	37	56	32	49	21	20	19	28	16	13					
15	72	42	63	36	54	23	22	21	31	18	14					
18	87	50	75	43	65	27	26	25	38	22	17					
24	115	67	100	58	87	36	35	33	50	29	23					
27	130	75	113	65	97	41	39	38	56	32	26					
30	144	83	125	72	108	46	43	42	63	36	29					
36	173	100	150	87	130	55	52	50	75	43	35					
45	216	125	188	108	163	68	65	63	94	54	43					
54	260	150	225	130	195	82	78	75	113	65	52					
81	389	225	338	195	292	123	117	113	169	97	78					

ASME units with amperage draw of 120 amps or more require factory installed internal fusing. *If the number of elements on non-fused models is different, it is located in parentheses (), following the amp draw.

kW Input	Recovery GPH Temperature Rise °F								
	40	50	60	70	80	90	100	120	140
3	31	25	21	18	16	14	12	10	9
6	62	50	41	35	31	28	25	21	18
9	93	74	62	53	47	42	37	31	27
12	124	99	83	71	62	55	50	41	35
13.5	140	112	93	80	70	62	56	47	40
15	155	124	103	89	78	69	62	52	44
18	186	149	124	106	93	83	74	62	53
24	248	199	164	142	124	110	99	83	71
27	279	223	186	160	140	124	112	93	80
30	310	248	207	177	155	138	124	103	89
36	372	298	248	213	186	165	149	124	106
45	465	372	310	266	233	207	186	155	133
54	558	447	372	319	279	248	223	186	160
81	852	671	558	477	418	371	334	278	238

Commercial Electric Water Heater

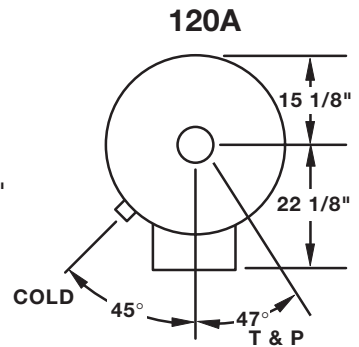
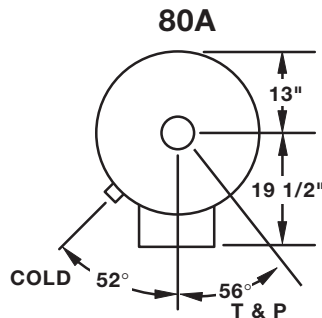
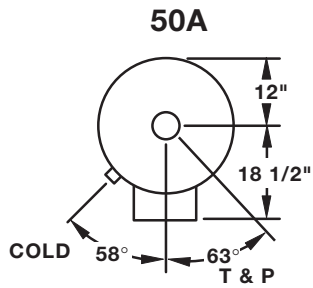
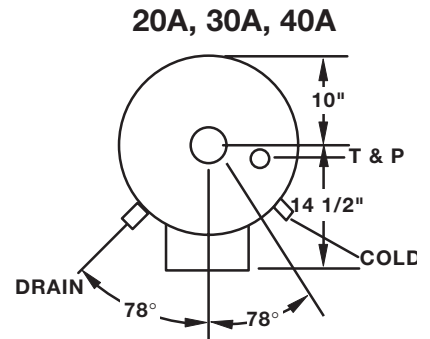
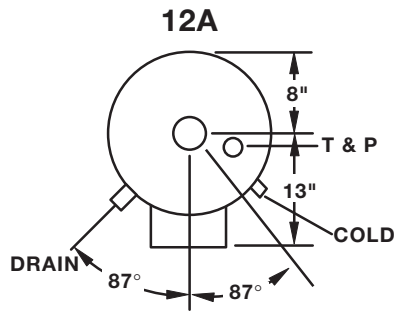
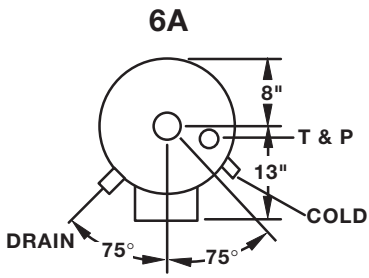
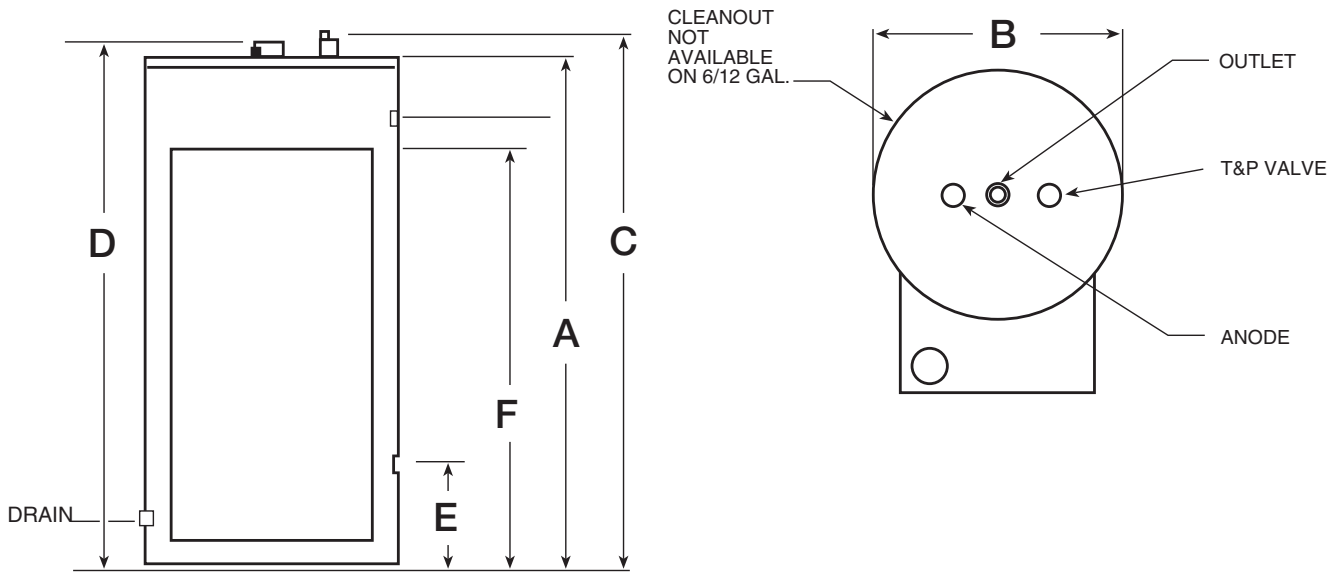

Commercial Electric Water Heater

Optional Components

- **High and Low Water Pressure Controls**—The Controls interrupt the electrical current to the contactor coil when the pressure settings are exceeded.
- **Low Water Level Control**—This Control will interrupt the electrical current to the contactor coil when a low water level condition is sensed inside the water heater tank. When the low water level condition is corrected the control will automatically sense the new situation and electrical current will again energize the contactor coil. Normal water heater operation will be resumed.
- **Alarm Horn**—The Alarm Horn is an option specified when the installation desires an audible signal to immediately sound an alert when the water heater operation is interrupted for certain faults. Referring to the control circuit wiring diagram, the alarm will activate when any one of the following events occur:
 - The Hi-Limit control has been tripped
 - The High Water Pressure Control senses excessive pressure
 - The Low Water Pressure Control senses insufficient pressure
 - The Low Water Level Control senses an insufficient quantity of water
- **Heating Element Sequencers**—Heating element sequencers are available in order to stage the activation of the heating elements thereby, reducing the inrush current to the water heater. The sequencers will control one or two contactor coils depending upon the water heater voltage, phase, and kW.
- **Electrical Door Lock**—An electrical door lock is offered in order to secure the access to the water heater control cabinet. This device will lock the control cabinet door when the 120VAC control circuit voltage is applied to it.
- **Temperature and Pressure Gauge**—Displays approximate temperature of the water and approximate pressure inside the tank.
- **BMS Relay**.

Sample Specification

The water heater shall be a Bradford White model with a rated storage capacity of not less than _____ gallons (_____ liters), a minimum kW input of _____ kW (_____ BTU/Hr.), a minimum recovery of _____ GPH (_____ LPH). The tank shall be Vitraglas® lined and have a bolted hand hole cleanout. The tank shall have _____ magnesium anode rods installed in separate tank head couplings. The heater shall have 3" Non-CFC foam insulation, and come equipped with an ASME rated T&P relief valve, a cold water inlet Hydrojet® Sediment Reduction System. It shall be design certified by ETL for 180°F (82°C) application, either with or without a separate storage tank, and comply with state and local codes and ordinances.

General

All electric water heaters are certified at 300 PSI test pressure (2068 kPa) and 150 PSI working pressure (1034 kPa). All models are design certified by ETL, for up to 180°F (82°C) application as an Automatic Storage Heater, and an Automatic Circulating Tank Heater. As an Automatic Storage Heater, all models are complete, self-contained water heating systems. It needs no separate storage tank, pump, wiring or elaborate piping network. When equipped with a mixing valve, it will supply 180°F (82°C) sanitizing and lower temperature general purpose hot water simultaneously. These models can be used either as a single unit or in multiples connected in series or parallel (recommended).

Dimensions and specifications subject to change without notice in accordance with our policy of continuous product improvement.



Ambler, PA

For U.S. and Canada field service, contact your professional installer or local Bradford White sales representative.

Sales 800-523-2931 • Fax 215-641-1670 / Technical Support 800-334-3393 • Fax 269-795-1089 • Warranty 800-531-2111 • Fax 269-795-1089

International: Telephone 215-641-9400 • Telefax 215-641-9750 / www.bradfordwhite.com

BRADFORD WHITE-CANADA® INC. Sales / Technical Support 866-690-0961 / 905-238-0100 • Fax 905-238-0105 / www.bradfordwhite.com

Built to be the Best™

©2016, Bradford White Corporation. All rights reserved.