

PRODUCT SHEET

MERIDIAN DUO

60" X 31" X 21"



THERMOMASSEUR® BATH	\$
THERMASENS™ BATH	\$
SOAKER BATH	\$

THERMOMASSEUR (TMU)	
Jets	36
1 heated backrest	included
Mia® Control	included
Geysair™	\$
AromaCloud™	\$
Chromatherapy - LED	\$

THERMASENS (TMSU)	
AromaCloud™	included
Chromatherapy - LED	included
WarmTouchShell™	included
2 DOT controls (standard location)	included

FEATURES INCLUDED			
Installation type		Alcove (3 walls)	
No. of bathers		Integrated tile flange and skirt with removable panel.	included
US gallons	35		
Imp. gallons	29		

OPTIONAL UPCHARGE APPLICABLE

COLORS

Standards	
	White
	Bone
	Biscuit
	Almond

Optionals		\$
	Black	
	Mexican sand	
	Cashmere	
	Sandbar	
	Gray	

CONTROL (TMU ONLY)

MiaMulti®	\$
-----------	----

DRAIN & OVERFLOW

	16" X 35"
Chrome	\$
White, Biscuit & Bone	\$
Brass	\$
Brushed nickel, Polished nickel & Oil-rubbed bronze	\$

DON'T FORGET THAT AN INTEGRATED TILE FLANGE IS AVAILABLE AT NO EXTRA COST. YOU MUST SPECIFY DRAIN POSITION. WHITE ONLY.

1 800 463.2187
info@bainultra.com

From 8 a.m. to 8 p.m. Monday to Thursday (EST)
From 8 a.m. to 5 p.m. on Friday (EST)

BainUltra®
The quest for your wellness™
www.bainultra.com

MERIDIAN DUO 60" X 31" X 21"

ACCESSORIES (OPTIONAL)

INTEGRATED TILE FLANGE Included (specify right or left).

OTHER Integrated skirt with removable panel.

TOTAL PRICE \$

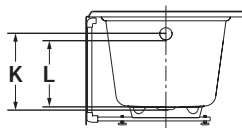
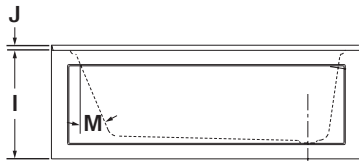
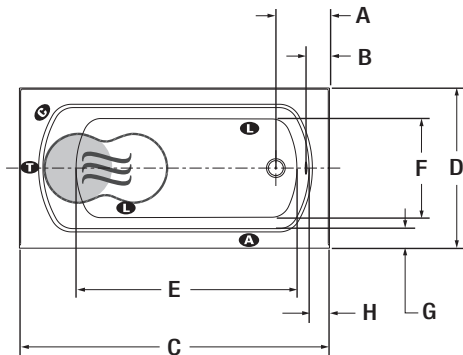

LETTER	DESCRIPTION	MEASURE
A	Outside edge to center drain	10 3/8"
B	Outside edge to overflow	5 7/8"
C	Total length	60"
D	Total width	31"
E	Bathing well length	42 3/4"
F	Bathing well width	19 5/16"
G	Deck width	3 1/4"
H	Deck width at drain end	4"
I	Height from bottom of tub to top deck	21"
J	Tile flange height	1"
K	Height from drain to center of overflow	14 5/8"
L	Maximum water level	13"
M	Slope of backrest	23°

- T** Indicates turbine position (TMU)
- L** Indicates LED light position
- Indicates heated backrest (TMU)
- C** Indicates control position when factory-installed
- ☰** Indicates WarmTouchShell position (TMSU)
- A** Indicates AromaCloud position

When tiling flange is added, the AromaCloud will automatically be installed on the opposite side of the flange.

TECHNICAL SPECIFICATIONS

Hot water supply required	Should be 70% of water capacity of tub or greater.
Turbine	Access to the pump must be at least 18" X 22". Standard connection is 15 A. 120 V, 60 hz, dedicated line with a Ground-Fault Circuit Interrupter (GFCI). With Geysair, upgrade to 20 A. 120 V, 60 hz, dedicated line GFCI is needed. For any additional option with the Geysair, a second line is needed 15 A. 120 V, 60 hz, dedicated line with a GFCI. Air vent necessary: 2" X 4" minimum.

Our products must be installed by certified professionals only and according to our Owner's Manual as well as federal, provincial/state and local building codes and regulations (www.bainultra.com/documentations).

Approx. shipping weight	136 lbs
Turbine power	600 W
Air heater	700 W

WARRANTY

Controls-LED-Geysair*	5 years
Bath & turbine*	20 years

*Some restrictions apply | www.bainultra.com/warranty



The specifications shown indicate the outer edge dimension and the inside bathing capacity dimension measured at air jets' height. The manufacturer accepts a 1/4" [0,64 cm] variance. There are variations on each product and specifications are subject to change as we improve upon our product as required. The dimensions needed for site preparation and structure building will differ. BainUltra® assumes no responsibility for preparatory work done prior to the product being on site.