

JOB:	REPRESENTATIVE:	
UNIT TAG:	ORDER NO.	DATE:
ENGINEER:	SUBMITTED BY:	DATE:
CONTRACTOR:	APPROVED BY:	DATE:

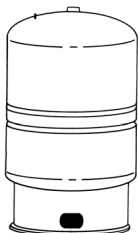

Series "WT"

Hydro-Pneumatic Tanks

For Potable Well Water Systems

DESCRIPTION

The Series "WT" tank will help protect the pump and pressure switches against short cycling. The domestic well tank delivers adequate water under pressure between pump cycles to meet the required demand. It will provide economical system operation by minimizing pump starts, extending pump motor life, and saving energy. The "WT" tank will also assist the pump in meeting peak demand.

CONSTRUCTION

Shell: Steel
 System Connection: Malleable Iron
 WT-401 – WT-405: Butyl Diaphragm
 Polypropylene Liner
 WT-421 – WT-457: Butyl Bladder
 Factory Precharged:
 WT-401 - WT-405: 30 PSI
 WT-421 - WT-457: 25 PSI

PERFORMANCE LIMITATIONS

Maximum Design Pressure:
 WT-401 – WT-405 150 PSI (1035 kPa)
 WT-421 – WT-427 100 PSI (689 kPa)
 WT-447 – WT-457 150 PSI (1035 kPa)
 Maximum Design Temperature:
 WT-401 – WT-405 200°F (93 °C)
 WT-421 – WT-457 240 °F (116 °C)

SCHEDULE

PART NUMBER	MODEL NUMBER	VOLUME GALLONS (LITERS)		TAGGING INFORMATION	QUANTITY
		TANK	ACCEPTANCE		
1BN101	WT-401	18 (68)	11.7 (44)		
1BN102	WT-402	25 (95)	11.3 (43)		
1BN103	WT-403	34 (129)	11.2 (42)		
1BN104	WT-404	68 (257)	34 (129)		
1BN105	WT-405	90(341)	35.1 (133)		
1BN106	WT-421	158 (600)	102.7 (389)		
1BN107	WT-422	211 (800)	137.2 (519)		
1BN108	WT-423	264 (1000)	171.6 (650)		
1BN109	WT-424	317 (1200)	206.1 (780)		
1BN110	WT-426	422 (1600)	274.3 (1038)		
1BN111	WT-427	528 (2000)	343.2 (1300)		
1BN112	WT-447	53 (200)	34.5 (130)		
1BN113	WT-448	80 (300)	52 (197)		
1BN114	WT-449	106 (400)	68.9 (261)		
1BN115	WT-450	132 (500)	85.8 (325)		
1BN116	WT-451	158 (600)	102.7 (389)		
1BN117	WT-452	211 (800)	137.2 (519)		
1BN118	WT-453	264 (1000)	171.6 (650)		
1BN119	WT-454	317 (1200)	206.1 (780)		
1BN120	WT-455	370 (1400)	240.5 (910)		
1BN121	WT-456	422 (1600)	274.3 (1038)		
1BN122	WT-457	528 (2000)	343.2 (1300)		

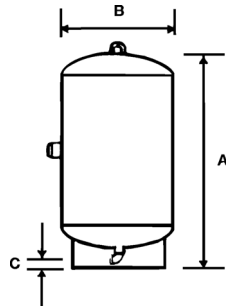

Models WT-401 through WT-405

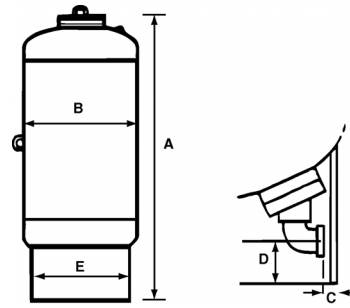

Models WT-421 through WT-457

DIMENSIONS IN INCHES (MM)

Model	A Height	B Diameter	C	D	E	System Connection	Shipping Wt Lbs. (Kg)
WT-401	31-1/4 (794)	16-1/4 (413)	1-1/2 (38)	N/A	N/A	1" NPTF	95 (43)
WT-402	39-3/4 (1010)	16-1/4 (413)	1-1/2 (38)	N/A	N/A	1" NPTF	112 (51)
WT-403	49-1/4 (1251)	16-1/4 (413)	1-1/2 (38)	N/A	N/A	1" NPTF	123 (56)
WT-404	47-1/4 (1200)	24 (610)	1-5/8 (41)	N/A	N/A	1-1/4" NPTF	210 (95)
WT-405	59-1/2 (1511)	24 (610)	1-5/8 (41)	N/A	N/A	1-1/4" NPTF	280 (127)
WT-421	74-5/8 (1895)	30 (762)	3-1/4 (83)	4-1/4 (108)	24 (610)	2" NPTF	308 (140)
WT-422	92-5/8 (2353)	30 (762)	3-1/4(83)	4-1/4 (108)	24(610)	2" NPTF	431 (195)
WT-423	82-1/8 (2086)	36 (914)	4-1/2 (114)	5-1/16 (128)	30 (762)	3" NPTF	503 (229)
WT-424	94-1/2 (2400)	36 (914)	4-1/2 (114)	5-1/16 (128)	30 (762)	3" NPTF	567 (258)
WT-426	81-5/8 (2073)	48 (1219)	7-3/8 (187)	6-1/8 (156)	42 (1067)	3" NPTF	906 (412)
WT-427	95-7/8 (2435)	48 (1219)	7-3/8 (187)	6-1/8 (156)	42 (1067)	3" NPTF	1026 (466)
WT-447	45-1/4 (1150)	24 (610)	2 (51)	3-3/4 (95)	19 (483)	2" NPTF	263 (120)
WT-448	59-1/8 (1502)	24 (610)	2 (51)	3-3/4 (95)	19 (483)	2" NPTF	308 (140)
WT-449	73-1/8 (1857)	24 (610)	2 (51)	3-3/4 (95)	19 (483)	2" NPTF	352 (160)
WT-450	86-5/8 (2200)	24 (610)	2 (51)	3-3/4 (95)	19 (483)	2" NPTF	392 (178)
WT-451	73-1/4 (1861)	30 (762)	3-1/2 (89)	5-1/2 (140)	24 (610)	2" NPTF	513 (233)
WT-452	91 (2312)	30 (762)	3-1/2 (89)	5-1/2 (140)	24 (610)	2" NPTF	760 (345)
WT-453	86 (2184)	36 (914)	4-1/2 (114)	7 (178)	30 (762)	3" NPTF	810 (367)
WT-454	98 (2489)	36 (914)	4-1/2 (114)	7 (178)	30 (762)	3" NPTF	914 (415)
WT-455	110-3/8 (2804)	36 (914)	4-1/2 (114)	7 (178)	30 (762)	3" NPTF	1018 (462)
WT-456	81-7/8 (2080)	48 (1219)	7-1/2 (191)	7-1/8 (181)	42 (1067)	3" NPTF	1655 (750)
WT-457	97-1/4 (2470)	48 (1219)	7-1/2 (191)	7-1/8 (181)	42 (1067)	3" NPTF	1925 (873)

NOTE: All dimensions are approximate.

TYPICAL SPECIFICATIONS

Furnish and install as shown on plans a _____ gallon (_____ liter), _____" (_____ mm) diameter x _____" (_____ mm) high pre-charged vertical steel hydro-pneumatic diaphragm tank with integral heavy duty butyl diaphragm. The tank shall have a _____" NPT system connection, and a .302"-32 charging valve connection (standard tire valve) to facilitate on-site charging of the tank to meet system requirements.

The water connections are malleable iron. The tank must be designed for a maximum working pressure of _____ PSI (_____ kPa) and maximum working temperature of _____ °F (_____ °C).

Each tank shall be ITT Industries – Bell & Gossett Model No. _____



Bell & Gossett

Bell & Gossett
8200 N. Austin Avenue, Morton Grove, IL 60053
Phone (847)966-3700
Facsimile (847)966-9052
www.bellgossett.com

