

## CYCLONE<sup>®</sup> Xi

**UP TO 96% THERMAL EFFICIENCY, DIRECT VENT**

### FEATURES

The A. O. Smith Cyclone Xi family of products represents the industry's most technologically advanced commercial water heaters. The innovative Cyclone Xi design takes performance to its highest level with efficiencies of 95% and 96%. Models are available from 120,000 BTUs up to 500,000 BTUs. In addition, the Cyclone Xi features an Intelligent Control system making it the smartest water heater in the industry. All models are ENERGY STAR<sup>®</sup> Qualified.

Cyclone Xi provides outstanding hot water output, with dramatic savings on operating costs compared to units with standard 80% efficiency. A. O. Smith's leading-edge engineering delivers conventional power-vent or power direct-vent versatility, low NOx emissions and excellent space-saving characteristics. Powered anodes, standard on all Cyclone Xi models, provide superior tank protection for years of trouble free operation.

#### INTELLIGENT CONTROL SYSTEM WITH LCD DISPLAY

- Exclusive A. O. Smith designed control system
- Provides detailed water heater status information
- Precise temperature control
- Built-in diagnostics
- Run history information
- Cyclone water heaters are iCOMM™ compatible and can be monitored from remote locations. Call 1.888.WATER02 for more information.



#### SUBMERGED COMBUSTION CHAMBER, WITH HELICAL HEAT EXCHANGER COIL

- Positioned in center of tank, surrounded by water to virtually eliminate radiant heat loss from chamber
- Spiral heat exchanger keeps hot burner gases swirling, uses centrifugal force to maximize efficiency of heat transfer to water in tank
- Spiral shaped heat exchanger reduces the accumulation of lime scale; maintains higher efficiency performance over time.

#### POWERED ANODES STANDARD ON ALL MODELS

- Provides long-lasting tank protection in varying water conditions
- Anodes are of a permanent design and do not require replacement unless damaged

#### PERMAGLAS<sup>®</sup> ULTRA COAT™ GLASSLINING

- Exclusive process provides superior protection against corrosion
- Both sides of heat exchanger coil are lined for protection against flue gas condensate inside coil

#### MECHANICAL VENTING VERSATILITY

- Conventional power-venting or power-direct venting
- Vents vertically or through sidewall
- Direct-vent intake and exhaust pipe can terminate separately outside building, or through single opening, using concentric vent assembly
- Uses inexpensive PVC, CPVC or ABS pipe for intake and exhaust. Canadian installations require ULC S636 listed PVC or CPVC pipe for intake and exhaust.

#### HIGH EFFICIENCY PRE-MIX POWERED BURNER

- Down-fired pre-mix burner provides optimum efficiency and quiet operation
- Top-mounted radial burner design ensures optimum combustion efficiency

**BTH-120  
through  
BTH-500**



**BTH-120-250**



**ASME  
(OPTIONAL)**





# Commercial Gas Water Heaters

## OTHER CYCLONE Xi FEATURES

### SPACE-SAVING DESIGN FOR INSTALLATION FLEXIBILITY

- Reduced footprint, ease of service, protection from water damage in case of flooding
- Easy to remove top cover for convenient access to serviceable parts
- 0" installation clearances on sides and rear, 4" installation clearance in front for Handhole Cleanout of unit and 1" installation clearance on top, however more room on top makes model easier to service.
- Handhole cleanout allows easy access to tank interior for cleaning
- 0" clearance to combustibles, approved for installation on combustible floors

### CODES AND STANDARDS

- CSA certified and ASME rated T&P relief valve
- Maximum hydrostatic working pressure: 160 PSI
- BTH-120-250 Models are design-certified by CSA International, according to ANSI Z21.10.3 - CSA 4.3 Standards governing storage-type water heaters.
- BTH-300-500 Models are design-certified by Underwriter's Laboratories (UL), Inc., according to ANSI Z21.10.3 - CSA 4.3 standards governing storage-type water heaters.
- Meets or exceeds the thermal efficiency and standby loss requirements of the U.S. Department of Energy and current edition ASHRAE/IESNA 90.1
- Design-certified by Underwriter's Laboratories (UL), Inc. to NSF standard 5
- Complies with SCAQMD Rule 1146.2 and other Air Quality Management Districts with similar requirements for low NOx emissions
- ASME tank construction optional on all models.

### THREE-YEAR LIMITED TANK WARRANTY

- For complete warranty details, consult written warranty shipped with heater, or contact A. O. Smith (5-year extended warranty is optional).

### INSTALLATION CONSIDERATIONS

1. Condensate Drain – This is a fully condensing water heater and should be located near a drain to permit proper disposal of condensate.
2. Vent Termination – Exhaust gases of this water heater are less than 140°F. In cold climates water vapor in flue gases will condense into a cloud of vapor where the vent exits the building. This vapor can gradually discolor exterior building surfaces. Vent termination should be located where this vapor cloud and potential discoloration are not a concern. Extending the vent termination up to 6" from the wall helps vapor from being trapped along a building's face. To avoid this problem, the vent can be terminated on the roof. Always locate vent termination above the maximum snowline, and do not locate vent termination above a walkway.
3. Air Intake – In cold climates, air intake should be located at least four feet from the vent termination of the water heater and any other appliance vents that discharge moisture-laden air (such as clothes dryers). This will help prevent freeze-over of the intake screen required to prevent foreign objects from entering the intake pipe. Air intake should be located above the maximum snowline.
4. Blockage Sensors – The water heater is equipped with sensors to shut it down if blockage of vent or air intake occurs. The water heater control system will display detailed diagnostic information on the LCD screen to help service technicians quickly locate and correct the problem.
5. Noise – Vent terminal should be located away from bedroom windows or other areas where blower noise will be objectionable. Avoid venting into corners or confined areas, which will amplify sound. Anchoring intake or vent pipe to walls or ceilings can cause noise to be transmitted to living areas, and isolation mounts should be used where anchoring is required.
6. Optional Concentric Vent Kit - Helps to minimize unsightly wall/roof penetrations.  
BTH-120 - 300 vent kit p/n 9006328005  
BTH-400 - 500 vent kit p/n 9006144005

For Technical Information and Automated Fax Service, call 800-527-1953. A. O. Smith Corporation reserves the right to make product changes or improvements without prior notice.

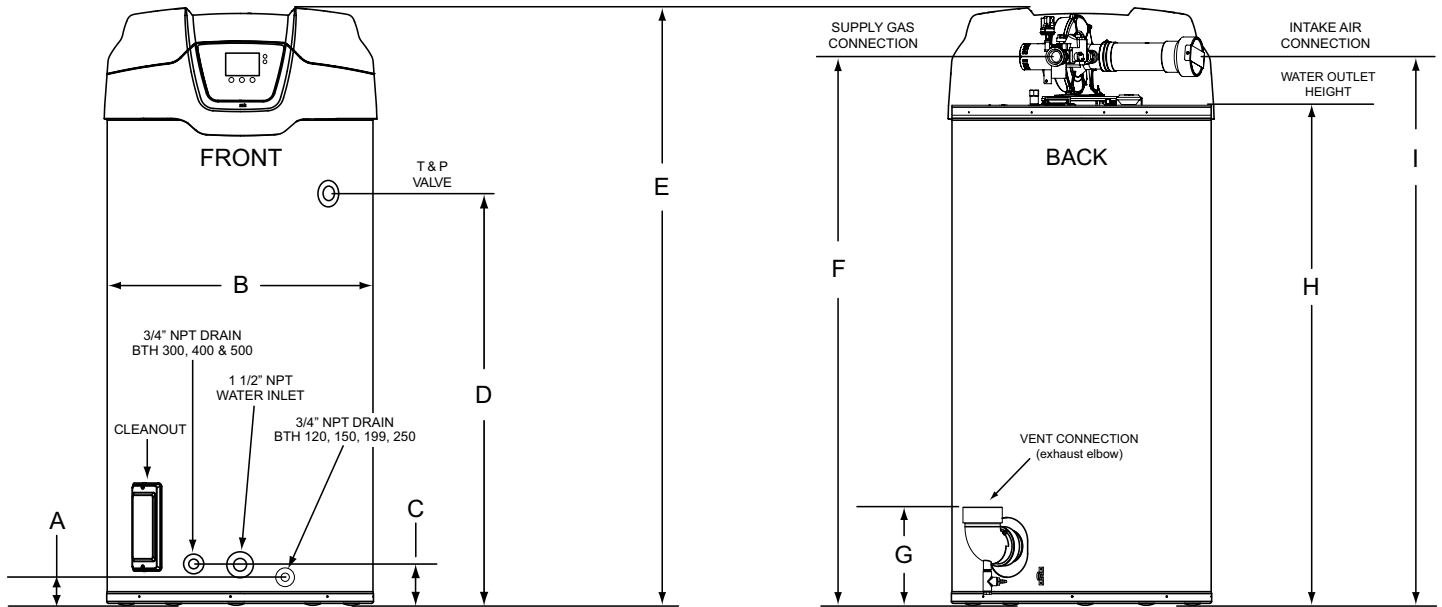

MODEL	DIMENSIONS										SHIP WEIGHT STD LBS/KG	SHIP WEIGHT ASME LBS/KG
	A	B	C	D	E	F	G	H	I			
	INCHES/CM	INCHES/CM	INCHES/CM	INCHES/CM	INCHES/CM	INCHES/CM	INCHES/CM	INCHES/CM	INCHES/CM			
BTH 120(A)	3/7.62	27.75/70.5	6.3/16	35/88.9	55.5/141	48/121.9	11/27.9	42/106.7	47.5/120.6	460/208	490/222	
BTH 150(A)	3/7.62	27.75/70.5	6.3/16	55.5/141	75.5/191.8	68.5/174	11/27.9	63/160	69/175.3	555/252	595/270	
BTH 199(A), 250(A)	3/7.62	27.75/70.5	6.3/16	55.5/141	75.5/191.8	75.5/191.8	11/27.9	63/160	69/175.3	555/252	595/270	
BTH 300(A), 400(A), 500(A)	N/A	33.12/84.1	4.86/12.34	50.77/129	75.5/191.8	69/175.3	12/30.5	63/160	69/175.3	855/408	855/408	

BTH 120 & 150

BTH 199 & 250

BTH 300, 400 & 500

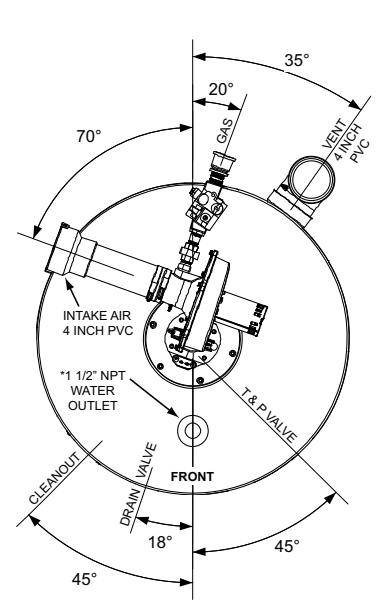
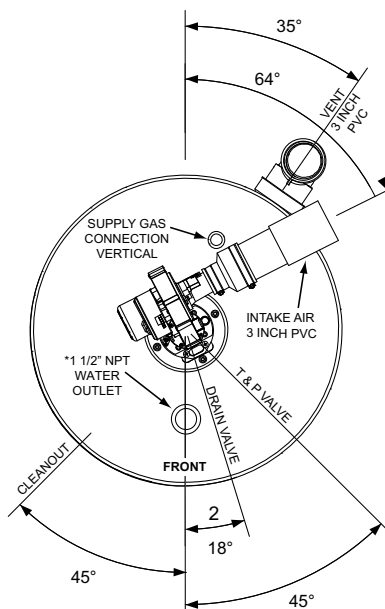
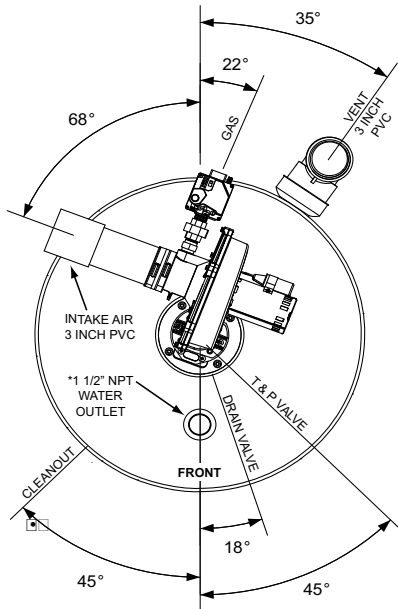

\* Center line of water outlet on top of the water heaters is approximately 7 inches from the front edge of the water heater

For Technical Information and Automated Fax Service, call 800-527-1953. A. O. Smith Corporation reserves the right to make product changes or improvements without prior notice.

## MAXIMUM EQUIVALENT VENT LENGTHS BTH 120 - 250

*Number of 90° Elbows Installed	3 Inch Pipe	4 Inch Pipe
	Maximum Feet (Meters)	Maximum Feet (Meters)
One (1)	45 feet (13.7 meters)	115 feet (35.0 meters)
Two (2)	40 feet (12.2 meters)	110 feet (33.5 meters)
Three (3)	35 feet (10.7 meters)	105 feet (32.0 meters)
Four (4)	30 feet (9.1 meters)	100 feet (30.5 meters)
Five (5)	-----	95 feet (29.0 meters)
Six (6)	-----	90 feet (27.4 meters)

\* Maximum number of 90° elbows allowed for the vent (exhaust) pipe is four (4) when installing 3 inch pipe and six (6) when installing 4 inch pipe. Maximum number of 90° elbows allowed for intake air pipe is four (4) when installing 3 inch pipe and six (6) when installing 4 inch pipe. Two (2) 45° elbows equal one (1) 90° elbow.

## MAXIMUM EQUIVALENT VENT LENGTHS BTH 300 - 500

*Number of 90° Elbows Installed	4 Inch Pipe	6 Inch Pipe
	Maximum Feet (Meters)	Maximum Feet (Meters)
One (1)	65 feet (19.8 meters)	115 feet (35.0 meters)
Two (2)	60 feet (18.2 meters)	110 feet (33.5 meters)
Three (3)	55 feet (16.8 meters)	105 feet (32.0 meters)
Four (4)	50 feet (15.2 meters)	100 feet (30.5 meters)
Five (5)	45 feet (13.7 meters)	95 feet (29.0 meters)
Six (6)	40 feet (12.2 meters)	90 feet (27.4 meters)

\* Maximum number of 90° elbows allowed for the vent (exhaust) pipe is six (6). Maximum number of 90° elbows allowed on the intake air pipe is six (6). Two (2) 45° elbows equal one (1) 90° elbow.

MINIMUM SUPPLY GAS LINE SIZE		
MODEL	NATURAL GAS	PROPANE GAS
BTH 120(A)	1/2" NPT	1/2" NPT
BTH 150(A)	3/4" NPT	3/4" NPT
BTH 199(A)	3/4" NPT	3/4" NPT
BTH 250(A)	3/4" NPT	3/4" NPT
BTH 300(A)	1 1/4" NPT	1 1/4" NPT
BTH 400(A)	1 1/4" NPT	1 1/4" NPT
BTH 500(A)	1 1/2" NPT	1 1/4" NPT

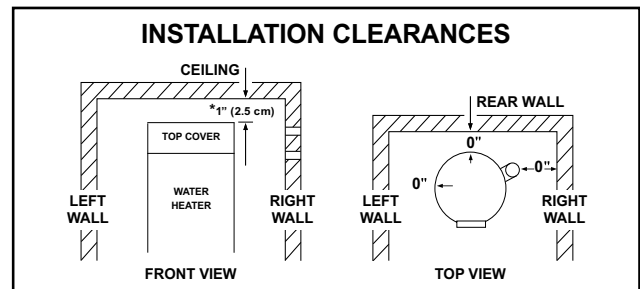

\*Minimum clearance to remove top cover

## INPUT/EFFICIENCIES

MODEL	TYPE OF GAS	INPUT		Thermal Efficiency	ASME	Non-ASME
		BTUH	KW			
BTH 120(A)	NATURAL/ PROPANE	120,000	35	95%	60 U.S. Gal/ 227 Litres	60 U.S. Gal/ 227 Litres
BTH 150 (A)	NATURAL/ PROPANE	150,000	44	95%	100 U.S. Gal/ 379 Litres	100 U.S. Gal/ 379 Litres
BTH 199 (A)	NATURAL/ PROPANE	199,900	58	95%	100 U.S. Gal/ 379 Litres	100 U.S. Gal/ 379 Litres
BTH 250 (A)	NATURAL/ PROPANE	250,000	73	95%	100 U.S. Gal/ 379 Litres	100 U.S. Gal/ 379 Litres
BTH 300 (A)	NATURAL/ PROPANE	300,000	88	96%	130 U.S. Gal/ 497 Litres	119 U.S. Gal/ 450 Litres
BTH 400 (A)	NATURAL/ PROPANE	399,900	117	95%	130 U.S. Gal/ 497 Litres	119 U.S. Gal/ 450 Litres
BTH 500 (A)	NATURAL/ PROPANE	499,900	146	95%	130 U.S. Gal/ 497 Litres	119 U.S. Gal/ 450 Litres

Recovery capacities are based on heater performance at 95% and 96% thermal efficiency.

Add "A" to model number when ordering ASME.

Maximum gas supply pressure for 120-250: 10.5" W.C. natural gas 14" W.C. propane. Maximum gas supply pressure for 300-500 10.0" W.C. natural gas 12.0" W.C. propane. Electrical requirements: 120 VAC/60Hz, Blower 2.2 Amps FL, Igniter 4.0 Amps.



# Commercial Gas Water Heaters

MODEL	U.S. Gallons/Hr and Litres/HR at TEMPERATURE RISE INDICATED												
	F°	30F°	40F°	50F°	60F°	70F°	80F°	90F°	100F°	110F°	120F°	130F°	140F°
	C°	17C°	22C°	28C°	33C°	39C°	44C°	50C°	56C°	61C°	67C°	72C°	78C°
BTH 120(A)	GPH	461	345	276	230	197	173	154	138	126	115	106	99
	LPH	1744	1308	1046	872	747	654	581	523	476	436	402	374
BTH 150 (A)	GPH	576	432	345	288	247	216	192	173	157	144	133	123
	LPH	2179	1635	1308	1090	934	817	726	654	594	545	503	467
BTH 199 (A)	GPH	767	575	460	384	329	288	256	230	209	192	177	164
	LPH	2904	2178	1743	1452	1245	1089	968	871	792	726	670	622
BTH 250 (A)	GPH	960	720	576	480	411	360	320	288	262	240	221	206
	LPH	3632	2724	2179	1816	1557	1362	1211	1090	991	908	838	778
BTH 300 (A)	GPH	1164	873	699	582	499	436	388	349	318	291	269	250
	LPH	4406	3304	2644	2203	1888	1652	1469	1322	1201	1102	1017	945
BTH 400 (A)	GPH	1552	1164	931	776	665	582	517	466	423	388	359	332
	LPH	5875	4406	3525	2938	2518	2203	1958	1763	1602	1469	1356	1259
BTH 500 (A)	GPH	1919	1439	1151	959	822	720	640	576	523	480	443	411
	LPH	7263	5447	4358	3631	3113	2724	2421	2179	1981	1816	1676	1556

## SUGGESTED SPECIFICATION

(Natural or Propane) gas water heater(s) shall be A. O. Smith Cyclone Xi model # \_\_\_\_\_ or equal, with up to 96% thermal efficiency, a storage capacity of \_\_\_\_\_ gallons, an input rating of \_\_\_\_\_ BTUs per hour, a recovery rating of \_\_\_\_\_ gallons per hour (gph) at 100°F rise and a maximum hydrostatic working pressure of 160 PSI. Water heater(s) shall: 1. Have seamless glasslined steel tank construction, with glass lining applied to all water-side surfaces after the tank has been assembled and welded; 2. Meet the thermal efficiency and standby loss requirements of the U. S. Department of Energy and current edition of ASHRAE/IESNA 90.1 3. Have foam insulation and a CSA Certified and ASME rated T&P relief valve; 4. Have a down-fired power burner designed for precise mixing of air and gas for optimum efficiency, requiring no special calibration on start-up; 5. Be approved for 0" clearance to combustibles.

Heater shall be supplied with maintenance-free powered anode.

The control shall be an integrated solid-state temperature and ignition control device with integral diagnostics, graphic user interface, fault history display, and shall have digital temperature readout.

1. The BTH-120-250 models are design-certified by CSA International, according to ANSI Z21.10.3 - CSA 4.3 standards governing storage-type water heaters. The BTH-300-500 models are design-certified by Underwriter's Laboratories (UL), Inc., according to ANSI Z21.10.3 - CSA 4.3 standards governing storage type water heaters; 2. Meet the thermal efficiency and standby loss requirements of the U. S. Department of Energy and current edition ASHRAE/IESNA 90.1. Complies with SCAQMD Rule 1146.2 and other air quality management districts with similar requirements for low NOx emissions.

120K-250K BTU Input:

For Standard Power Venting: Water heater(s) shall be suitable for standard power venting using a (3" or 4") \_\_\_\_\_ diameter PVC pipe for a total distance of (50ft. or 120 ft.) \_\_\_\_\_ equivalent feet of vent piping.

For Power Direct Venting: Water heater(s) shall be suitable for power direct venting using a (3" or 4") \_\_\_\_\_ diameter PVC pipe for a total distance of (50ft. or 120 ft.) \_\_\_\_\_ equivalent feet of vent piping and (50ft. or 120 ft.) \_\_\_\_\_ equivalent feet of intake air piping.

300K - 500K BTU Input:

For Standard Power Venting: Water heater(s) shall be suitable for standard power venting using a (4" or 6") \_\_\_\_\_ diameter PVC pipe for a total distance of (70ft. or 120 ft.) \_\_\_\_\_ equivalent feet of vent piping.

For Power Direct Venting: Water heater(s) shall be suitable for power direct venting using a (4" or 6") \_\_\_\_\_ diameter PVC pipe for a total distance of (70ft. or 120 ft.) \_\_\_\_\_ equivalent feet of vent piping and (70ft. or 120 ft.) \_\_\_\_\_ equivalent feet of intake air piping.

Operation of the water heater(s) in a closed system where thermal expansion has not been compensated for (with a properly sized thermal expansion tank) will void the warranty.

Water heater should incorporate the iCOMM™ system for remote monitoring, leak detection and fault alert.

For Technical Information and Automated Fax Service, call 800-527-1953. A. O. Smith Corporation reserves the right to make product changes or improvements without prior notice.



# Commercial Gas Water Heaters

For Technical Information and Automated Fax Service, call 800-527-1953. A. O. Smith Corporation reserves the right to make product changes or improvements without prior notice.