



Product information presented here reflects conditions at time of publication. Consult factory regarding discrepancies or inconsistencies.

MAIL TO: P.O. BOX 16347 • Louisville, KY 40256-0347
SHIP TO: 3649 Cane Run Road • Louisville, KY 40211-1961
(502) 778-2731 • 1 (800) 928-PUMP • FAX (502) 774-3624

visit our web site:
<http://www.zoeller.com>

REPLACEMENT PARTS LIST FOR MODELS:

H295 AUTOMATIC 208V/1PH
I295 NONAUTOMATIC 208V/1PH
J295 NONAUTOMATIC 208V/3PH
F295 NONAUTOMATIC 230V/3PH
G295 NONAUTOMATIC 460V/3PH
BA295 NONAUTOMATIC 575V/3PH

Consult factory for all others models

TO ORDER REPLACEMENT PARTS PLEASE FURNISH THE FOLLOWING INFORMATION:

- Model Number.
- Part Number of Pump.
(If manufactured prior to June 1988, give 2 letter date code following Model Number).
- Part Number and Description of part.

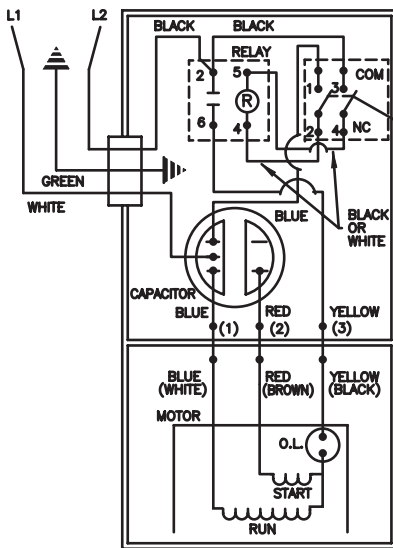

004622

WIRING DIAGRAM FOR MODELS
"H295-A", "H295-B" and "H295-C"
5/86 (RS) to Current

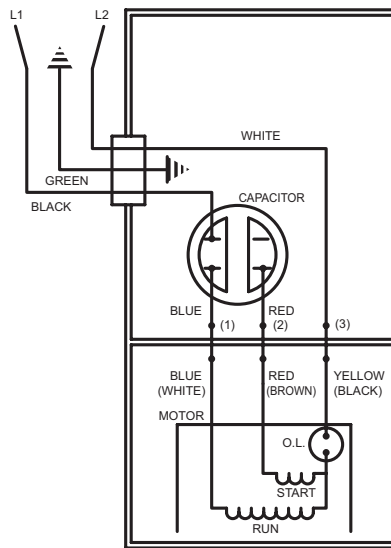

002397

WIRING DIAGRAM FOR MODELS
"I295-A", "I295-B" and "I295-C"
5/86 (RS) to Current

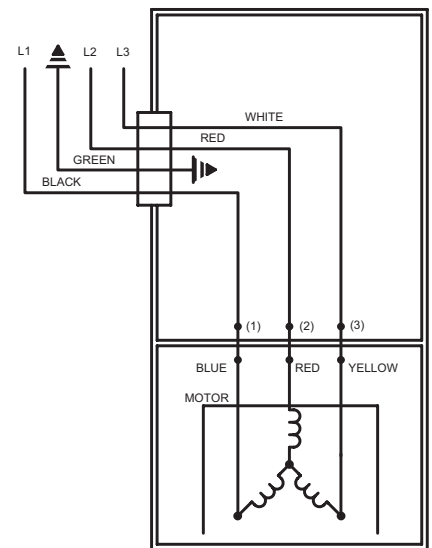

006848

WIRING DIAGRAM FOR MODELS
"J295", "F295", "G295" and "BA295"
All Revisions 1/86 thru Current

REPLACEMENT PARTS LIST FOR MODEL "H295".

See page 4 for illustration.

REF. NO.	DESCRIPTION	QTY	NOTES	MODELS:		
				H295-A	H295-B	H295-C
				5/86 RS thru 8/86 US	9/86 VS thru 4/03	5/03 thru Current
1	Case Sw & Cord 230V/1Ph/14ga	1	3,4	005125	014332	014157
2	• Guard	1		001023	001023	001023
3	Case-Mach "189/295"	1	3,4	004633	004633	014154
4	• Arm & Seal Asm "160/180/290"	1	4	004745	004745	004745
5	• Gasket,Case/Cover	1		001011	001011	001011
6	Switch Asm "160/180/290"	1	4	004744	004744	004744
7	• Wire Pkg(5)Wires 1.5/2 HP	1		004751	004751	004751
8	Relay 230V G1 (&G5)	1	2	297005	217093	217093
9	Capacitor & clamp Asm	1		006135	006135	006135
10	Float,Plastic	1		094039	094039	094039
11	Guide Asm,Fit Rod	1		001072	001072	001072
12	Rod Asm,Fit	1		001043	001043	001043
13	Housing,Mtr-&Str230/1P/1.5-2HP	1	1	005204	005204	005204
14	• Bearing, Upper	1		001012	001012	001012
15	• Handle	1		217069	217069	217069
16	Cord Term&Seal 20/230V/20a/A	1	3	005126	014331	014170
17	Clamp,#6 Auto-SS	1	3	NA	NA	013764
18	• Seal,Cord-Asm&Str Rlf T&B 14ga	1	3	004375	004375	015634
19	• Plug,Test-White	2		034090	034090	034090
20	• Seal,Thru Wall Term	3		003402	003402	003402
21	Rotor & Brg Asm 230/1P/1.5-2HP	1		005205	005205	005205
22	• Bearing,Radial	1		001013	001013	001013
23	• Seal,Mtr Hsg	1		001014	001014	001014
24	• Oil,Dielectric-(38 Oz Can)	1		003168	003168	003168
25	Adapter-Mach	1		001003	001003	001003
26	• Seal,Shaft	1		002430	002430	002430
27	Flange Pkg 2"Npt	1		217024	217024	217024
	Flange Pkg 3"Npt	1		317024	317024	317024
28	Impeller Br "295"	1		004173	004173	004173
29	Housing,Pump-Mach	1		001005	001005	001005
30	• Screw,#10-24 X.375 RHM-SI SS	2		001883	001883	001883
31	• Screw,#6-32x.25RHM SI Tc Stlgr	4		001877	001877	001877
32	• Screw,.25-20 X .75 HHm-SS	4		001916	001916	001916
33	• Screw,#6-32x.438Rhsstp"1"Stlzi	2		004644	004644	004644
34	• Screw,.5-13 X 2 HH Cap-SS	2		001909	001909	001909
35	• Washer,SS-1.25"Odx.562"ldx.078	2		002115	002115	002115
36	• Screw,.313-18 X 1"HH Cap-SS	4		002608	002608	002608
37	• Screw,.25-20x1" HHm-SS	4		007790	007790	007790
▣	Rebuild Kit "189/295"	1		016103	016103	016103

- Items included in Rebuild Kit.
- ▣ Not Shown in Illustration.

NOTES FOR MODEL H295:

- 1) Mtr. Hsg., Brg., Stator & Term. (Item 13) is preassembled at the factory and must be replaced as a unit. Stator is permanently attached to the Motor Housing. Plug (Item 19), Seal, Thru Wall Term. (Item 20) and Bearing - Upper (Item 14) are replaceable.
- 2) Relay "W1" and "W2" Series is not in pump but is in the high level control. See FM0456 "W1" Parts List or FM0457 "W2" Parts List for relay part number.
- 3) If an "X" follows Model No., or Date Mfg. on brass ID tag, consult factory for ordering of this part.
- 4) When ordering these parts, customer must identify if switch is a General Electric switch.
- 5) See FM0160 Parts Price Sheet for listing of parts prices.
- 6) "NA" indicates, not applicable.

REPLACEMENT PARTS LIST FOR MODEL "I295".

See page 4 for illustration.

REF. NO.	DESCRIPTION	QTY	NOTES	MODELS:		
				I295-A	I295-B	I295-C
1	• Handle	1		5/86 RS thru 8/86 US	9/86 VS thru 4/03	5/03 thru Current
2	Cover & Cord 230V/1P "189/295"	1	2	005129	014160	014160
3	Cover-Mach 14ga Cd	1	2	004372	004372	014150
4	• Gasket,Case/Cover	1		001011	001011	001011
5	• Wire Pkg(5)Wires 1.5/2 HP	1		004751	004751	004751
6	Capacitor & Clamp Asm	1		006135	006135	006135
7	Housing,Mtr-&Str230/1P/1.5-2HP	1	1	005204	005204	005204
8	Bearing,Sleeve	1		001012	001012	001012
9	Cord Term&Seal 20'/230V/20a/Na	1	2	005200	009685	014171
10	Clamp,#6 Auto-SS	1	2	NA	NA	013764
11	• Seal,Cord-Asm&Str Rif T&B 14ga	1	2	004375	004375	015634
12	• Plug,Test-White	2		034090	034090	034090
13	• Seal,Thru Wall Term	3		003402	003402	003402
14	Rotor & Brg Asm 230/1P/1.5-2HP	1		005205	005205	005205
15	• Bearing,Radial	1		001013	001013	001013
16	• Seal,Mtr Hsg	1		001014	001014	001014
17	• Oil,Dielectric-(38 Oz Can)	1		003168	003168	003168
18	Adapter-Mach	1		001003	001003	001003
19	• Seal,Shaft	1		002430	002430	002430
20	Flange Pkg 2"Npt	1		217024	217024	217024
	Flange Pkg 3"Npt	1		317024	317024	317024
21	Impeller Br "295"	1		004173	004173	004173
22	Housing,Pump-Mach	1		001005	001005	001005
23	• Screw,#6-32x.25RHM SI Tc Stlgr	3		001877	001877	001877
24	• Screw,#10-24 X.375 RHM-SI SS	1		001883	001883	001883
25	• Screw,.25-20 X .75 HHm-SS	4		001916	001916	001916
26	• Screw,.5-13 X 2 HH Cap-SS	2		001909	001909	001909
27	• Washer,SS-1.25"Odx.562"Idx.078	2		002115	002115	002115
28	• Screw,.313-18x1" HH Cap-SS	4		002608	002608	002608
29	• Screw,.25-20x1" HHm-SS	4		007790	007790	007790
▣	Rebuild Kit "189/295"	1		014193	014193	014193

• Items included in Rebuild Kit.

▣ Not Shown in Illustration.

NOTES FOR MODEL I295:

- 1) Mtr. Hsg., Brg., Stator & Term. (Item 7) is preassembled at the factory and must be replaced as a unit. Stator is permanently attached to the Motor Housing. Plug (Item 12), Seal, Thru Wall Term. (Item 13) and Bearing - Upper (Item 8) are replaceable.
- 2) If an "X" follows Model No., or Date Mfg. on brass ID tag, consult factory for ordering of this part.
- 3) See FM0160 Parts Price Sheet for listing of parts prices.
- 4) "NA" indicates, not applicable.

DATE CODE OF MANUFACTURE FROM 12/70 TO 12/88					
1st LETTER MONTH			2nd LETTER YEAR		
M — JAN.	T — JULY	A — 1971	G — 1977	O — 1983	
N — FEB.	U — AUG.	B — 1972	H — 1978	P — 1984	
O — MARCH	V — SEPT.	C — 1973	I — 1979	R — 1985	
P — APRIL	W — OCT.	D — 1974	J — 1980	S — 1986	
R — MAY	X — NOV.	E — 1975	M — 1981	T — 1987	
S — JUNE	Y — DEC.	F — 1976	N — 1982	U — 1988	

REPLACEMENT PARTS ILLUSTRATION FOR MODELS "H295".

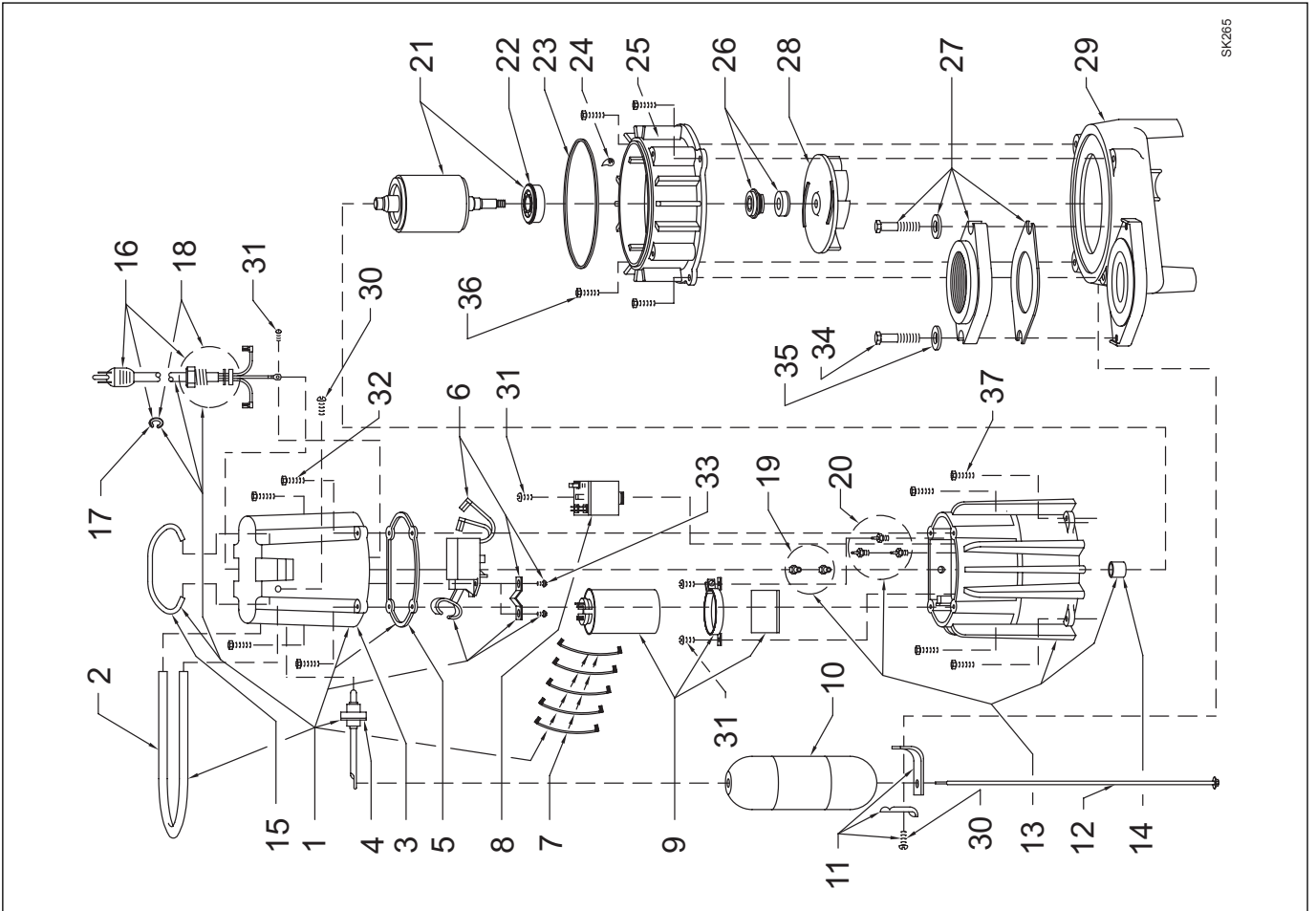

SKK265

REPLACEMENT PARTS ILLUSTRATION FOR MODEL "I295".

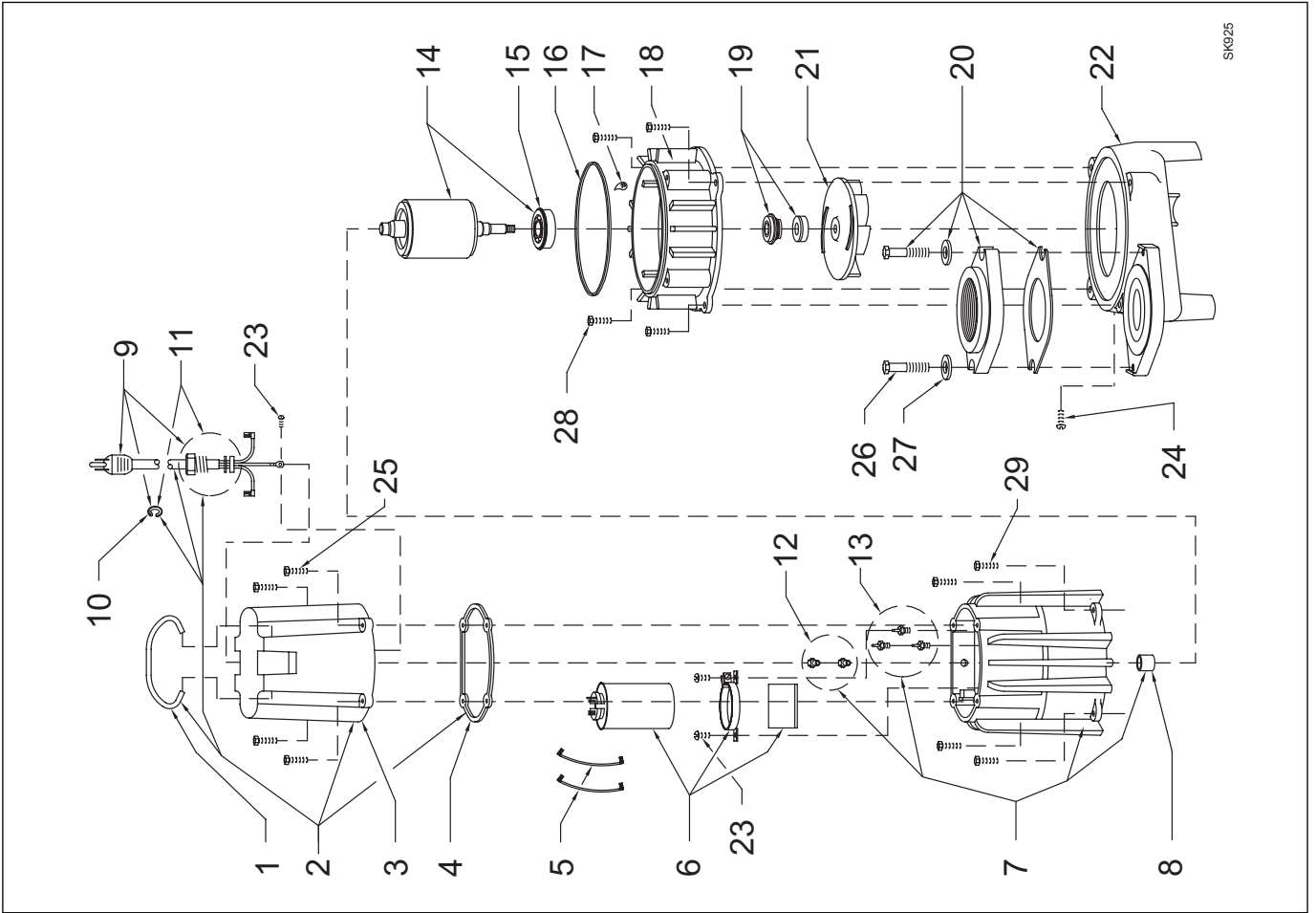

SKK265

REPLACEMENT PARTS LIST FOR MODEL "J295".

See page 8 for illustration.

REF. NO.	DESCRIPTION	QTY	NOTES	MODELS:			
				J295-A	J295-B	J295-C	J295-D
				1/86 MS thru 8/86 US	9/86 VS thru 5/87 RT	6/87 VS thru 4/03	5/03 thru Current
1	• HANDLE	1		217069	217069	217069	217069
2	COVER & CORDAGE 14-4GA 20'	1	2	002963	002963	011641	014161
3	COVER-MACH	1	2	001077	001077	004372	014150
4	• GASKET, CASE/COVER	1		001011	001011	001011	001011
5	HOUSING,MTR-&STR.	1	1	005132	005132	005132	005132
6	BEARING, SLEEVE	1		001012	001012	001012	001012
7	• CLAMP,STRAIN RELIEF-RED	1	2	001770	001770	NA	013764
8	CORDAGE TERM&SEAL 14-4GA 20'	1	2	005131	005131	011640	014177
9	• SEAL, CORD-ASM & STRAIN RELIEF	1	2	011656	011656	004375	015634
10	• PLUG,TEST-WHITE	2		034090	034090	034090	034090
11	• SEAL,THRU WALL TERM	3		003402	003402	003402	003402
12	ROTOR & BEARING	1		005133	005133	005133	005133
13	• BEARING,RADIAL	1		001013	001013	001013	001013
14	• SEAL, MTR HSG.	1		001014	001014	001014	001014
15	• OIL,DIELECTRIC- (38 OZ CAN)	1		003168	003168	003168	003168
16	ADAPTER-MACH	1		001003	001003	001003	001003
17	• SEAL,SHAFT	1		002430	002430	002430	002430
18	IMPELLER	1		005134	005134	005134	005134
19	FLANGE PKG 2"NPT	1		217024	217024	217024	217024
	FLANGE PKG 3"NPT	1		317024	317024	317024	317024
20	HOUSING,PUMP-MACH	1		001005	001005	001005	001005
21	• SCREW,#6-32X.25RHM SI Tc Stlgr	1		001877	001877	001877	001877
22	• SCREW,.25-20X.75 HHM-SS	4		001916	001916	001916	001916
23	• SCREW,.313-18X1"HH CAP-SS	4		002608	002608	002608	002608
24	• SCREW,.5-13X2"HH CAP-SS	2		001909	001909	001909	001909
25	• WASHER,SS-1.25" O.D. X .562 I.D.	2		002115	002115	002115	002115
26	• SCREW,#10-24X.375 RHM-SI SS	1		001883	001883	001883	001883
27	• SCREW,.25-20 X 1" HHM-SS	4		007790	007790	007790	007790
28	NUT,7/16-20 ACORN SS	1		004351	004351	004351	004351
▣	REBUILD KIT -NA 3PH "160/180/290"	1		014193	014193	014193	014193

- Items included in Rebuild Kit.
- ▣ Not Shown in Illustration.

NOTES FOR MODEL J295:

- 1) Mtr. Hsg., Brg., Stator & Term. (Item 5) are preassembled at the factory and must be replaced as a unit. Stator is permanently attached to the Motor Housing. Plug (Item 10), Seal, Thru Wall Term. (Item 11) and Bearing - Upper (Item 6) are replaceable.
- 2) When ordering Mtr. Hsg., Brg., Stator & Term. or Rotor and Bearing, specify either GE or Emerson motor.
- 3) See FM0160 Parts Price Sheet for listing of parts prices.
- 4) "NA" indicates, not applicable.

REPLACEMENT PARTS LIST FOR MODEL "F295".

See page 8 for illustration.

REF. NO.	DESCRIPTION	QTY	NOTES	MODELS:			
				F295-A	F295-B	F295-C	F295-D
				1/86 MS thru 8/86 US	9/86 VS thru 5/87 RT	6/87 VS thru 4/03	5/03 thru Current
1	• HANDLE	1		217069	217069	217069	217069
2	COVER & CORDAGE 14-4GA 20'	1	2	002963	002963	011641	014161
3	COVER-MACH	1	2	001077	001077	004372	014150
4	• GASKET, CASE/COVER	1		001011	001011	001011	001011
5	HOUSING,MTR-&STR.	1	1	005136	005136	005136	005136
6	BEARING, SLEEVE	1		001012	001012	001012	001012
7	• CLAMP,STRAIN RELIEF-RED	1	2	001770	001770	NA	013764
8	CORDAGE TERM&SEAL 14-4GA 20'	1	2	005131	005131	011640	014177
9	• SEAL, CORD-ASM & STRAIN RELIEF	1	2	011656	011656	004375	015634
10	• PLUG,TEST-WHITE	2		034090	034090	034090	034090
11	• SEAL,THRU WALL TERM	3		003402	003402	003402	003402
12	ROTOR & BEARING	1		005133	005133	005133	005133
13	• BEARING,RADIAL	1		001013	001013	001013	001013
14	• SEAL, MTR HSG.	1		001014	001014	001014	001014
15	• OIL,DIELECTRIC- (38 OZ CAN)	1		003168	003168	003168	003168
16	ADAPTER-MACH	1		001003	001003	001003	001003
17	• SEAL,SHAFT	1		002430	002430	002430	002430
18	IMPELLER	1		005134	005134	005134	005134
19	FLANGE PKG 2"NPT	1		217024	217024	217024	217024
	FLANGE PKG 3"NPT	1		317024	317024	317024	317024
20	HOUSING,PUMP-MACH	1		001005	001005	001005	001005
21	• SCREW,#6-32X.25RHM SI Tc Stlgr	1		001877	001877	001877	001877
22	• SCREW,.25-20X.75 HHM-SS	4		001916	001916	001916	001916
23	• SCREW,.313-18X1"HH CAP-SS	4		002608	002608	002608	002608
24	• SCREW,.5-13X2"HH CAP-SS	2		001909	001909	001909	001909
25	• WASHER,SS-1.25" O.D. X .562 I.D.	2		002115	002115	002115	002115
26	• SCREW,#10-24X.375 RHM-SI SS	1		001883	001883	001883	001883
27	• SCREW,.25-20 X 1" HHM-SS	4		007790	007790	007790	007790
28	NUT,7/16-20 ACORN SS	1		004351	004351	004351	004351
▣	REBUILD KIT -NA 3PH *160/180/290*	1		014193	014193	014193	014193

- Items included in Rebuild Kit.
- ▣ Not Shown in Illustration.

NOTES FOR MODEL F295:

- 1) Mtr. Hsg., Brg., Stator & Term. (Item 5) are preassembled at the factory and must be replaced as a unit. Stator is permanently attached to the Motor Housing. Plug (Item 10), Seal, Thru Wall Term. (Item 11) and Bearing - Upper (Item 6) are replaceable.
- 2) When ordering Mtr. Hsg., Brg., Stator & Term. or Rotor and Bearing, specify either GE or Emerson motor.
- 3) See FM0160 Parts Price Sheet for listing of parts prices.
- 4) "NA" indicates, not applicable.

REPLACEMENT PARTS LIST FOR MODELS "G295" and "BA295".

See page 8 for illustration.

REF. NO.	DESCRIPTION	MODELS:		G295-A	G295-B	BA295-A
		QTY	NOTES	1/86 MS thru 8/86 US	9/86 VS thru Current	9/90 thru Current
1	• HANDLE	1		217069	217069	217069
2	COVER & CORDAGE 14-4GA 20'	1	2	002963	002963	002963
3	COVER-MACH	1	2	001077	001077	001077
4	• GASKET, CASE/COVER	1		001011	001011	001011
5	HOUSING,MTR-&STR.	1	1	004578	004578	006288
6	BEARING, SLEEVE	1		001012	001012	001012
7	• CLAMP,STRAIN RELIEF-RED	1	2	001770	001770	001770
8	CORDAGE TERM&SEAL 14-4GA 20'	1	2	005131	005131	005131
9	• SEAL, CORD-ASM & STRAIN RELIEF	1	2	011656	011656	011656
10	• PLUG,TEST-WHITE	2		034090	034090	034090
11	• SEAL,THRU WALL TERM	3		003402	003402	003402
12	ROTOR & BEARING	1		005133	005133	005133
13	• BEARING,RADIAL	1		001013	001013	001013
14	• SEAL, MTR HSG.	1		001014	001014	001014
15	• OIL,DIELECTRIC-(38 OZ CAN)	1		003168	003168	003168
16	ADAPTER-MACH	1		001003	001003	001003
17	• SEAL,SHAFT	1		002430	002430	002430
18	IMPELLER	1		005134	005134	005134
19	FLANGE PKG 2"NPT	1		217024	217024	217024
	FLANGE PKG 3"NPT	1		317024	317024	317024
20	HOUSING,PUMP-MACH	1		001005	001005	001005
21	• SCREW,#6-32X.25RHM SI Tc Stlgr	1		001877	001877	001877
22	• SCREW,.25-20X.75 HHM-SS	4		001916	001916	001916
23	• SCREW,.313-18X1"HH CAP-SS	4		002608	002608	002608
24	• SCREW,.5-13X2"HH CAP-SS	2		001909	001909	001909
25	• WASHER,SS-1.25" O.D. X .562 I.D.	2		002115	002115	002115
26	• SCREW,#10-24X.375 RHM-SI SS	1		001883	001883	001883
27	• SCREW,.25-20 X 1" HHM-SS	4		007790	007790	007790
28	NUT,7/16-20 ACORN SS	1		004351	004351	004351
▣	REBUILD KIT -NA 3PH "160/180/290"	1		014193	014193	014193

- Items included in Rebuild Kit.
- ▣ Not Shown in Illustration.

NOTES FOR MODEL G295 and BA295:

- 1) Mtr. Hsg., Brg., Stator & Term. (Item 5) are preassembled at the factory and must be replaced as a unit. Stator is permanently attached to the Motor Housing. Plug (Item 10), Seal, Thru Wall Term. (Item 11) and Bearing - Upper (Item 6) are replaceable.
- 2) When ordering Mtr. Hsg., Brg., Stator & Term. or Rotor and Bearing, specify either GE or Emerson motor.
- 3) See FM0160 Parts Price Sheet for listing of parts prices.
- 4) "NA" indicates, not applicable.

REPLACEMENT PARTS ILLUSTRATION FOR MODELS "J295", "F295", "G295" and "BA295".

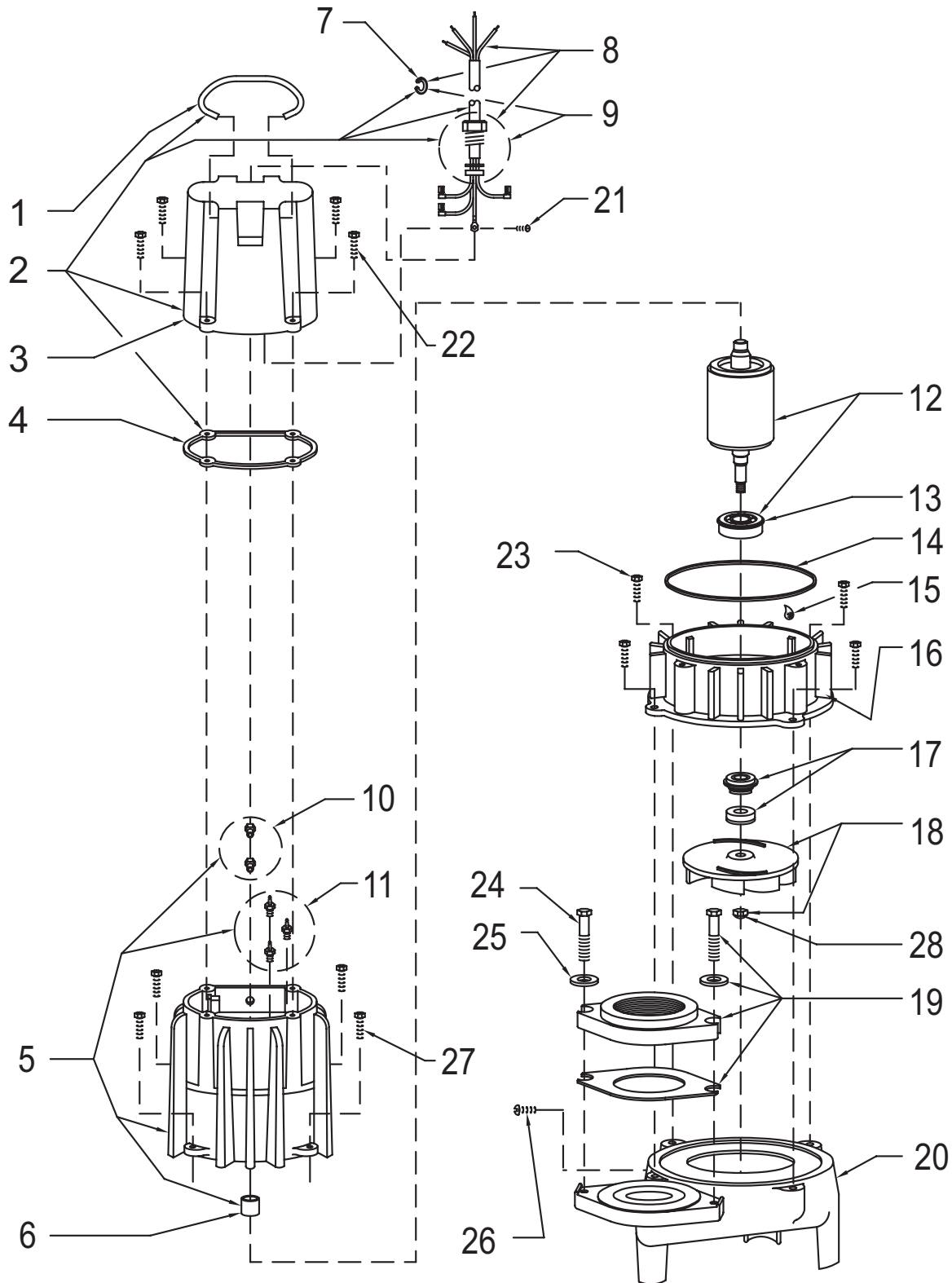

SK1285



<http://www.zoeller.com>

ZOELLER
PUMP CO.

MAIL TO: P.O. BOX 16347
Louisville, KY 40256-0347
SHIP TO: 3649 Cane Run Road
Louisville, KY 40211-1961
(502) 778-2731 • 1 (800) 928-PUMP
FAX (502) 774-3624

Manufacturers of..

"QUALITY PUMPS SINCE 1939"