

Replacement parts — EG/PEG

Table 13 EG/PEG replacement parts

Item	Description	Boiler Models	Part Number
A	Left hand end section with heater opening (Pattern No. 1814)	—	311-800-014
	Left end section without heater opening (Pattern No. 1813)	—	311-800-007
B	Right hand end section without heater opening (Pattern No. 18118)	—	311-800-029
C	Intermediate section (Pattern No. 1815)	—	311-800-010
D	Draft hood	EG-30	450-021-255
		EG-35	450-021-256
		EG-40	450-021-257
		EG-45	450-021-258
		EG-50	450-021-259
		EG-55	450-021-260
		EG-65	450-021-261
		EG-75	450-021-262
E	Collector hood	EG-30, 35	450-014-733
		EG-40, 45	450-014-734
		EG-50, 55	450-014-735
		EG-65	450-014-736
		EG-75	450-014-737
F	Burner, steel tube, regular stainless	—	512-200-000
F₁	Burner, steel tube, with pilot bracket “PI” system (ALL) “SPN” system (EG-75) “SPL” system (ALL)	—	512-200-001
	Burner, steel tube, with slot and pilot bracket “SPN” system (EG-30 & -65 Only)	—	512-200-002
G	Manifold	EG-30	591-125-533
		EG-35	591-125-538
		EG-40	591-125-534
		EG-45	591-125-539
		EG-50	591-125-535
		EG-55	591-125-540
		EG-65	591-125-541
		EG-75	591-125-542
	Main burner orifice, natural gas, 2.45mm (note 1) (not shown)	—	560-528-987
	Main burner orifice, propane gas, 1.55mm (note 1) (not shown)	—	560-528-988
	Section assembly, complete without heater opening (not shown)	EG-30, 35	321-811-095
	Section assembly, complete with heater opening (not shown)	EG-35	321-811-100
	Section assembly, complete with heater opening (not shown)	EG-40, 45	321-811-110
	Section assembly, complete without heater opening (not shown)	EG-40, 45	321-811-115
	Section assembly, complete with heater opening (not shown)	EG-50, 55	321-811-120
	Section assembly, complete without heater opening (not shown)	EG-50, 55	321-811-125
	Section assembly, complete with heater opening (not shown)	EG-65	321-811-130
	Section assembly, complete without heater opening (not shown)	EG-65	321-811-135
	Section assembly, complete with heater opening (not shown)	EG-75	321-811-140
	Section assembly, complete without heater opening (not shown)	EG-75	321-811-145
	Retort cement (1 quart) (not shown)	—	591-602-913
	Flue brush (not shown)	—	591-706-214

Item	Description	Boiler Models	Part Number
H	Front base panel	EG-30, 35	451-800-000
		EG-40, 45	450-800-001
		EG-50, 55	451-800-002
		EG-65	451-800-003
		EG-75	451-800-004
H₁	Base insulation kit (includes front and rear base panel insulation, water glass, and boiler cement)	—	510-811-660
H₂	Base front access panel with flame rollout switch bracket	EG-30, 35	451-800-040
		EG-40, 45	451-800-041
		EG-50	451-800-039
		EG-55	451-800-042
		EG-65	451-800-043
		EG-75	451-800-044
H₃	Back burner support	EG-30	451-800-085
		EG-35	451-800-086
		EG-40	451-800-087
		EG-45	451-800-088
		EG-50	451-800-089
		EG-55	451-800-090
		EG-65	451-800-092
		EG-75	451-800-094
		I	Back base panel
EG-40, 45	451-800-011		
EG-50, 55	451-800-012		
EG-65	451-800-013		
EG-75	451-800-014		
I₂	Base back channel	EG-30, 35	451-800-020
		EG-40, 45	451-800-021
		EG-50, 55	451-800-022
		EG-65	451-800-023
		EG-75	451-800-024
J	Base side rail (2 required)	—	451-800-070
K	Spill switch	—	510-300-013
L	Cover plate for heater opening (rectangular)	—	389-900-103
L₂	Gasket for cover plate (rectangular)	—	590-317-579
L₃	Cover plate for heater opening (round)	—	389-900-101
L₄	Gasket for cover plate (round)	—	590-317-495
	Section replacement kit (includes 3” and 6” elastomer seal, 4 ft. cope seal; order 1 per joint between sections) (not shown)	—	381-800-667
	3” diameter bottom elastomer seal (1 per joint) (not shown)	—	592-800-010
	6” diameter top elastomer seal (1 per joint) (not shown)	—	592-800-007
	Sealer for sections (cope seal – 4 ft. per joint) (not shown)	—	591-641-865
	½” Tie rod without nut (2 per boiler) (not shown)	EG-30, 35	560-234-470
	½” Tie rod without nut (2 per boiler) (not shown)	EG-40, 45	560-234-475
	½” Tie rod without nut (2 per boiler) (not shown)	EG-50, 55	560-234-480
	½” Tie rod without nut (2 per boiler) (not shown)	EG-65	560-234-485
	½” Tie rod without nut (2 per boiler) (not shown)	EG-75	560-234-490
	½” Nut (2 per tie rod) (not shown)	—	561-928-221
	½” Lock washer (1 per tie rod) (not shown)	—	562-248-668
Note 1: Order sufficient quantities to replace all orifices within a base.			

Replacement parts — EG/PEG *(continued)*

WARNING The boiler contains ceramic fiber and fiberglass materials. Use care when handling these materials per instructions on page 25 of this manual. Failure to comply could result in severe personal injury.

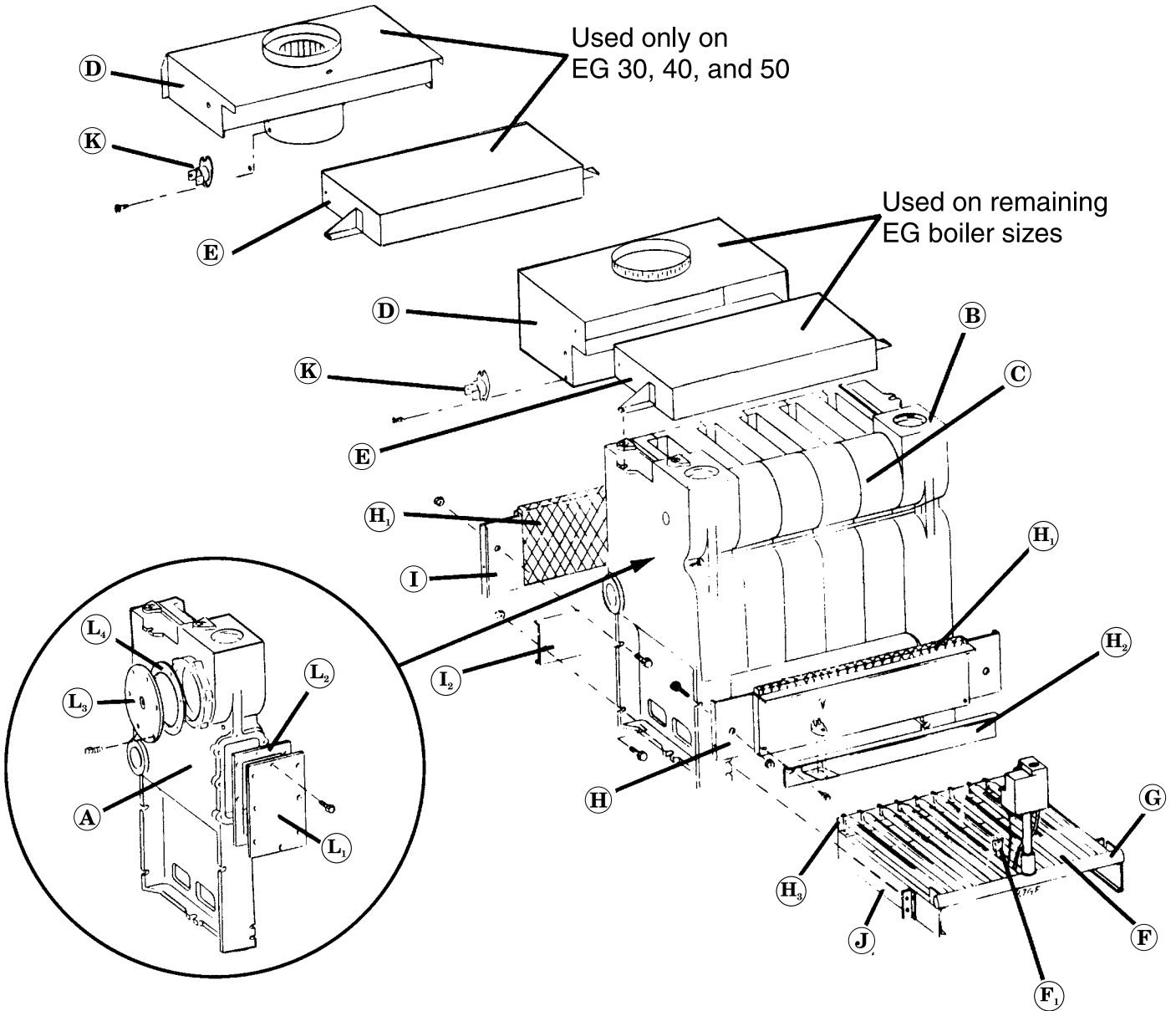

NOTE 1: Order sufficient quantities to replace all orifices within a base

Replacement parts — EGH

Table 14 EGH replacement parts

Item	Description	Boiler Models	Part Number
A	Left hand end section with heater opening (Pattern No. 1814)	—	311-800-014
	Left hand end section without heater opening (Pattern No. 1813)	—	311-800-007
B	Right hand end section with heater opening (Pattern No. 1819)	—	311-800-022
	Right hand end section without heater opening with control tappings (Pattern No. 18118)	—	311-800-032
C	Intermediate section (Pattern No. 1815)	—	311-800-010
	Intermediate section with tie rod lugs (Pattern No. 1817)	—	311-800-026
C ₁	3" Diameter bottom elastomer seal (1 per joint)	—	592-800-010
	6" Diameter top elastomer seal (1 per joint)	—	592-800-007
D	Draft hood	EGH-85	450-206-240
		EGH-95	450-206-241
		EGH-105	450-206-242
		EGH-115	450-206-243
		EGH-125	450-206-244
E	Collector hood	EGH-85	450-014-750
		EGH-95	450-014-751
		EGH-105	450-014-752
		EGH-115	450-014-753
		EGH-125	450-014-754
F	Burner, stainless tube, regular	—	512-200-000
F ₁	Burner, stainless tube, with pilot bracket	—	512-200-001
G	Manifold	EGH-85	591-125-543
		EGH-95	591-125-544
		EGH-105	591-125-545
		EGH-115	591-125-546
		EGH-125	591-125-547
	Main burner orifice, natural gas, 2.45mm (note 1)	—	560-528-987
	Main burner orifice, propane gas, 1.55mm (note 1)	—	560-528-988
H	Front base panel (in base panel carton)	—	—
H ₁	Front base insulation (in base panel carton)	—	—
H ₂	Base front access panel (in base panel carton)	—	—
H, H ₁ , H ₂ , I, I ₁ & I ₂	Base panel carton	EGH-85	381-700-240
		EGH-95	381-700-245
		EGH-105	381-700-250
		EGH-115	381-700-255
		EGH-125	381-700-260
I	Back base panel (in base panel carton)	—	—
I ₁	Back base insulation (in base panel carton)	—	—
I ₂	Back base channel (in base panel carton)	—	—
J	Side rail for burner panel with bracket for burner pan	—	451-800-070

Item	Description	Boiler Models	Part Number
J ₁	Back burner support	EGH-85	451-800-095
		EGH-95	451-800-096
		EGH-105	451-800-097
		EGH-115	451-800-098
		EGH-125	451-800-099
L ₁	Cover plate for heater opening (rectangular)	—	389-900-103
L ₂	Gasket for cover plate (rectangular)	—	590-317-579
L ₃	Cover plate for heater opening (round)	—	389-900-101
L ₄	Gasket for cover plate (round)	—	590-317-495
	Section assembly, complete with heater opening (not shown)	EGH-85	321-711-100
	Section assembly, complete without heater opening (not shown)	EGH-85	321-711-105
	Section assembly, complete with heater opening (not shown)	EGH-95	321-711-110
	Section assembly, complete without heater opening (not shown)	EGH-95	321-711-115
	Section assembly, complete with heater opening (not shown)	EGH-105	321-711-120
	Section assembly, complete without heater opening (not shown)	EGH-105	321-711-125
	Section assembly, complete with heater opening (not shown)	EGH-115	321-711-130
	Section assembly, complete without heater opening (not shown)	EGH-115	321-711-135
	Section assembly, complete with heater opening (not shown)	EGH-125	321-711-140
	Section assembly, complete without heater opening (not shown)	EGH-125	321-711-145
	Section replacement kit (includes 3" and 6" elastomer seal, 4 ft. cope seal; order 1 per joint between sections) (not shown)	—	381-800-667
	Burner shields (rollout)	EGH-85	451-800-120
		EGH-95	451-800-121
		EGH-105	451-800-122
EGH-115		451-800-123	
EGH-125		451-800-124	
	Sealer for sections (cope seal – 4 ft. per joint)	—	591-641-865
	½" x 7" Tie rod w/o nut (2 per boiler) (not shown)	—	560-234-465
	½" x 17" Tie rod w/o nut (not shown) (4 – EGH-85) (2 – EGH-95)	—	560-234-472
	½" x 21¼" Tie rod w/o nut (not shown) (2 – EGH-95) (2 – EGH-115) (4 – EGH-125)	—	560-234-477
	½" x 25¼" Tie rod w/o nut (not shown) (2 – EGH-115) (4 – EGH-125)	—	560-234-482
	½" Nut (2 per tie rod)	—	561-928-221
	½" Lock washer (1 per tie rod)	—	562-248-668
	Retort cement (1 quart)	—	591-602-913
	Flue brush (not shown)	—	591-706-214

Note 1: Order sufficient quantities to replace all orifices within a base.

Replacement parts — EGH *(continued)*

WARNING The boiler contains ceramic fiber and fiberglass materials. Use care when handling these materials per instructions on page 25 of this manual. Failure to comply could result in severe personal injury.

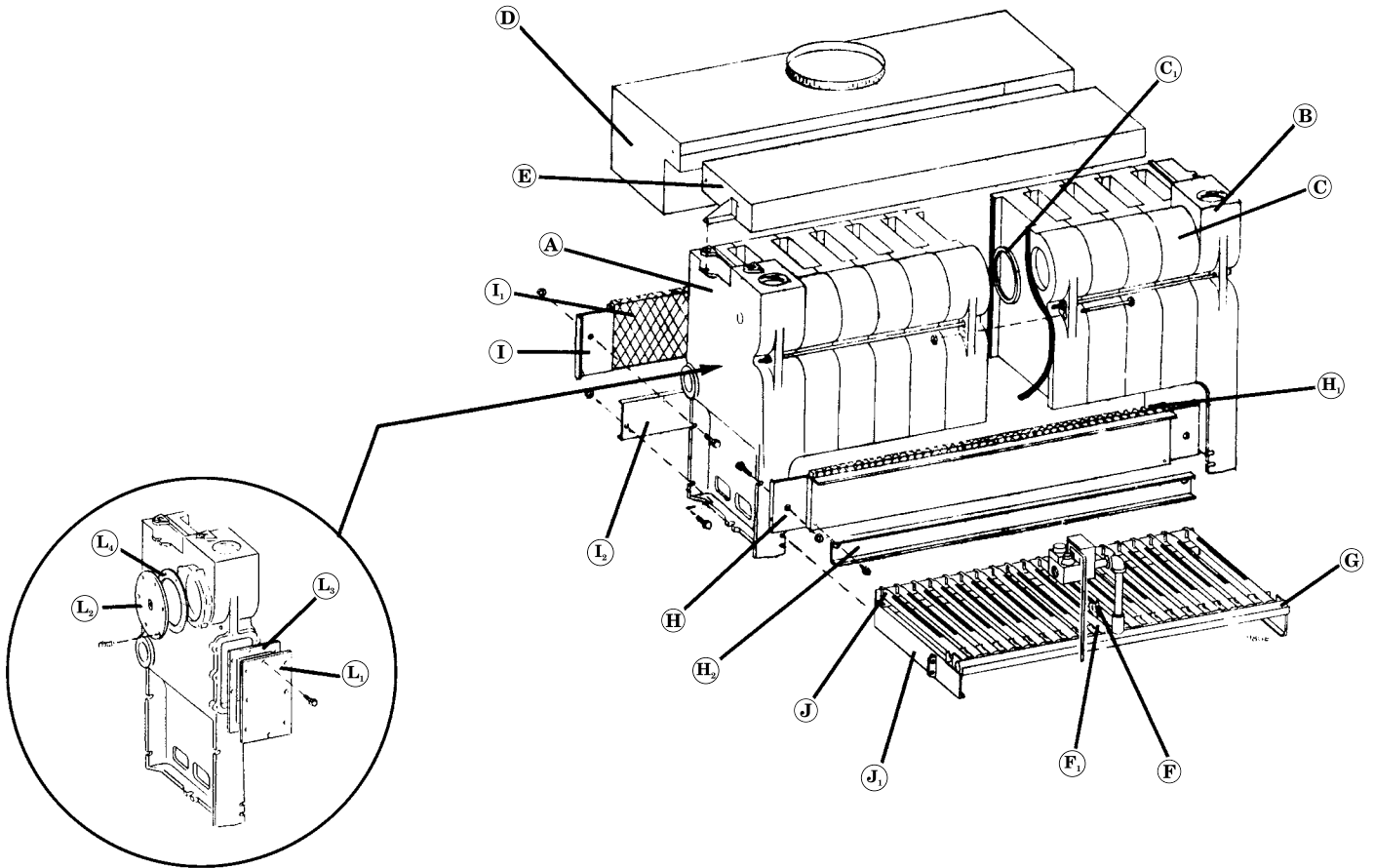

Dimensional data

Table 15 Dimensional data

Boiler number	Supply EG/EGH	Return EG/EGH	Dimensions (See note 3 for PEG-30 to PEG-55 crate dimensions)						Gas connection "F" (note 1)	Draft hood outlet size	Approx. ship. wt. (lbs.)
			W	A	B	B1	V (note 2)	T			
EG & PEG-30 & -35	1 - 3"	1 - 2 1/2"	17"	5"	11 3/4"	6 3/4"	6"	Water boiler tankless coil removal clearance: E-624: 14" E-626: 18" E-632: 22"	1/2"	5"	430
EG & PEG-40 & -45	1 - 3"	1 - 2 1/2"	21 1/4"	6"	11 3/4"	6 3/4"	6 1/2"		1/2"	6"	505
EG & PEG-50 & -55	1 - 3"	1 - 2 1/2"	25 1/2"	7"	11 3/4"	6 3/4"	9"		1/2"	7"	585
EG & PEG-65	1 - 3"	1 - 2 1/2"	29 3/4"	8"	11 3/4"	6 3/4"	9 1/2"		3/4"	8"	660
EG-75	1 - 3"	1 - 2 1/2"	34"	8"	15 3/4"	8 3/4"	—		3/4"	8"	735
EGH-85	2 - 3"	2 - 2 1/2"	38 1/4"	9"	15 3/4"	8 3/4"	—		3/4"	9"	825
EGH-95	2 - 3"	2 - 2 1/2"	42 1/2"	10"	15 3/4"	8 3/4"	—		3/4"	10"	915
EGH-105	2 - 3"	2 - 2 1/2"	46 3/4"	10"	15 3/4"	8 3/4"	—		1"	10"	1005
EGH-115	2 - 3"	2 - 2 1/2"	51"	12"	15 3/4"	8 3/4"	—		1"	12"	1095
EGH-125	2 - 3"	2 - 2 1/2"	55 1/4"	12"	15 3/4"	8 3/4"	—		1"	12"	1185

Notes:
 1. Sizes shown are gas connection sizes, natural or propane gas. Gas piping from meter to boiler to be sized according to local utility requirements. Gas line can enter through either the right or left end of the boiler.
 2. Damper dimension for EG-30 through EG-65 ONLY. For EG-75 and all EGH the damper is additional equipment.
 3. PEG crates are 32" wide by 39" high. Crate lengths are: 32" for PEG-30, -35, -40; 37" for PEG -45, -50, -and -55; 39" for PEG-65.

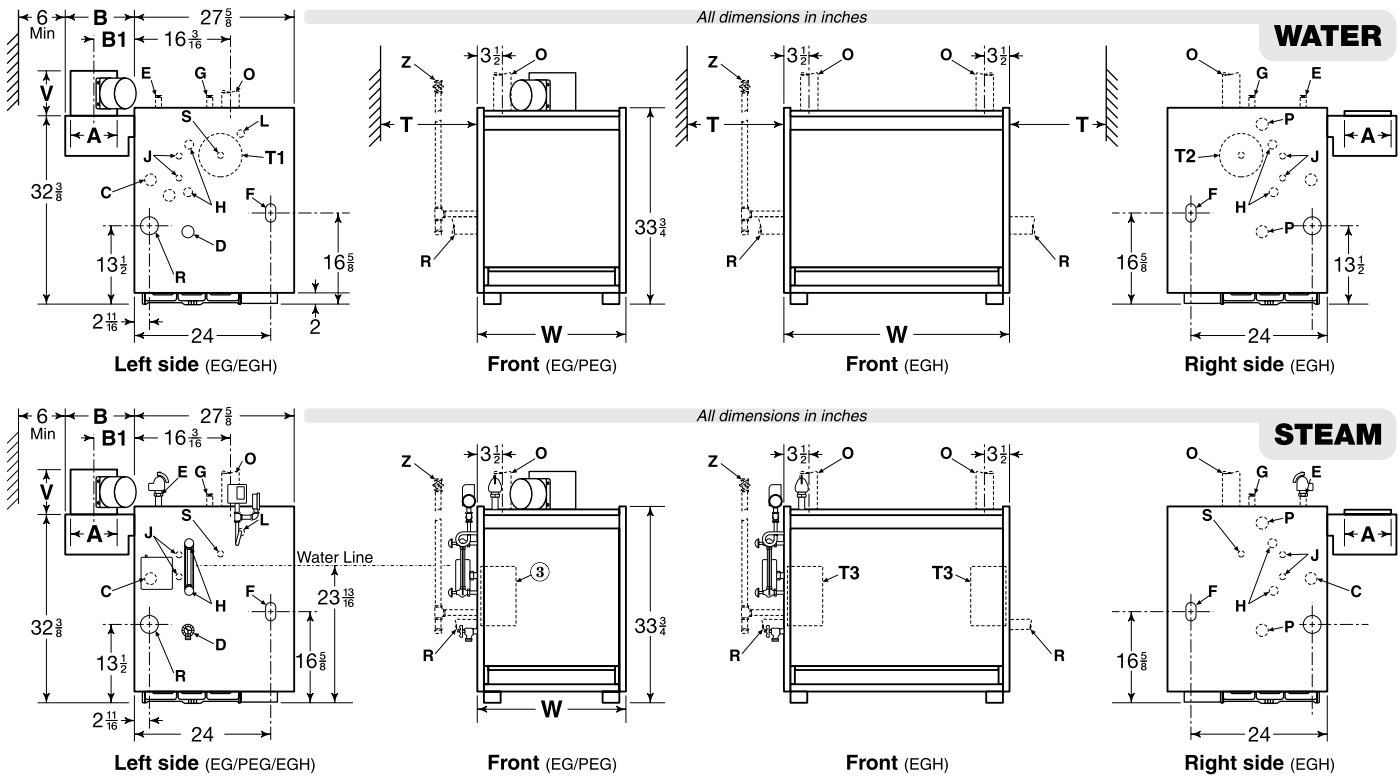

Tapping	Size	Steam Boilers	Water Boilers	Tapping	Size	Steam Boilers	Water Boilers
C	3/4"	Probe type low water cut-off	Probe type BWCO (when used)	P (EGH Only)	1"	Float type BWCO, pressure limit control and pressure gauge; or BWCO and feeder combination; or BWCO and pump control	Float type BWCO; or BWCO and feeder combination; or BWCO and pump control
D	3/4"	Drain	Drain	S	1 1/2"	Skim tapping	Limit control
E	3/4"	Safety valve	Safety relief valve		3/4"	— (note 1)	Limit control
G	3/4"	Plugged	Piping to compression tank or auto air vent	T1	—	—	Optional tankless heater for water boilers
H	1/2"	Gauge glass and/or optional BWCO	Combination pressure temperature gauge	T2	—	—	Optional tankless heater for EGH water boilers only
J	3/8"	Tri cock tapings	Plugged	T3	—	Optional steam boiler tankless heater	—
L	1/2"	Syphon, pressure gauge, high limit (Probe type BWCO)	Combination pressure temperature gauge	Z	—	Manual shut-off gas valve (supplied by installer)	—
Notes	1. Available on special request only when tankless heater is specified. 2. Limit control and supply piping must be on the same end of the EGH boiler			Notes	3. When a tankless water heater coil is installed, use the tapping in the heater for an additional operating		

Ratings



DOE

Table 16 Capacities

Boiler model number	0–2,000 feet altitude		2,000–4,500 feet altitude (Canada)		Net I=B=R ratings			Chimney size	Boiler water content (gallons)	
	Input (Btuh)	DOE Heating Capacity (Output) (Btuh)	Input (Btuh)	Output (Btuh)	Sq. Ft. Steam	Steam Btuh	Water Btuh		Water	Steam (to waterline)
(Notes 1 & 2)		(Note 3)	(Note 4)		(Note 5)					
*EG-30-	75,000	62,000	67,500	56,000	196	47,000	55,000	5" I.D. x 20'	12.3	8.4
*EG-35-	100,000	83,000	90,000	75,000	258	62,000	73,000	5" I.D. x 20'	12.3	8.4
*EG-40-	125,000	104,000	112,500	93,000	325	78,000	91,000	6" I.D. x 20'	14.8	9.8
*EG-45-	150,000	125,000	135,000	112,000	392	94,000	110,000	6" I.D. x 20'	14.8	9.8
*EG-50-	175,000	145,000	157,500	131,000	454	109,000	128,000	7" I.D. x 20'	17.3	11.2
*EG-55-	200,000	167,000	180,000	150,000	521	125,000	146,000	7" I.D. x 20'	17.3	11.2
*EG-65-	250,000	209,000	225,000	188,000	654	157,000	183,000	8" I.D. x 20'	19.8	12.6
EG-75-	300,000	240,000	270,000	216,000	750	180,000	209,000	8" I.D. x 20'	22.3	14.0
EGH-85-	349,900	280,000	315,000	252,000	875	210,000	243,000	9" I.D. x 20'	24.8	15.4
EGH-95-	400,000	320,000	360,000	288,000	1,000	240,000	278,000	10" I.D. x 20'	27.3	16.8
EGH-105-	450,000	360,000	--	--	1,125	270,000	313,000	10" I.D. x 20'	29.8	18.2
EGH-115-	500,000	400,000	--	--	1,250	300,000	348,000	12" I.D. x 20'	32.3	19.6
EGH-125-	550,000	440,000	--	--	1,375	330,000	383,000	12" I.D. x 20'	34.8	21.0

Notes (Table 16)

- * Add prefix “P” for package boiler completely assembled and wired with jacket and controls (PEG-30-S through PEG-65-S only).
- 1. **EG-30 thru 75:** Add suffix “SPD” or “SP” for standing pilot; add “PID” or “PI” for electronic ignition (30-65 — damper required in U.S.; optional in Canada); add “N” for natural; add “L” for propane; add “W” for water; add “S” for steam; add “T” for tankless heater; add “P” for provisional tankless heater.
EGH-85 & 95: Add suffix “SP” for standing pilot; add “PI” for electronic ignition (damper available on PI only); add “N” for natural; add “L” for propane; add “W” for water; add “S” for steam; add “T” for tankless heater (tankless available on EGH-85 thru 125 PI Water and Steam; EGH-85 and 95 SP Steam only); add “P” for provisional tankless heater.
EGH-105 thru 125: Add suffix “PI” for electronic ignition (damper available on PI only); add “W” for water; add “S” for steam; add “T” for tankless heater.
- 2. EGH water boilers tested for 50 P.S.I working pressure.
- 3. Based on standard test procedures prescribed by the United States Department of Energy.
EG-75 thru EGH-125: CSA Gross output.
- 4. EGH-105 thru 125 may be installed at altitudes of 2,000-4,500 feet subject to acceptance by Provincial Inspections Authority based on field tests of individual installations.
- 5. Net I=B=R ratings are based on net installed radiation of sufficient quantity for the requirements of the building and nothing need be added for normal piping and pick-up. Water ratings are based on a piping and pick-up allowance of 1.15; steam ratings on an allowance of 1.333. An additional allowance should be made for unusual piping and pick-up loads. Consult local Weil-McLain representative.

Table 17 DOE seasonal efficiencies

Boiler model number	DOE seasonal efficiency (AFUE)					
	Water			Steam		
	SPDN	SPDL	PIDN	SPDN	SPDL	PIDN
EG-30 PEG-30	82.2	84.2	84.3	81.0	82.9	83.0
EG-35 PEG-35	82.0	83.7	83.6	81.3	82.5	82.9
EG-40 PEG-40	82.5	84.3	84.0	81.5	83.2	82.9
EG-45 PEG-45	82.4	84.0	83.5	81.6	83.0	82.9
EG-50 PEG-55	82.9	84.4	83.8	81.9	83.7	82.8
EG-55 PEG-55	82.5	84.2	83.8	81.9	83.5	82.8
EG-65 PEG-65	82.6	84.0	84.0	82.0	82.8	83.0

Standard and optional equipment

Standard equipment

- Factory-Assembled Section Block
- Insulated Extended Jacket
- Draft Hood
- Aluminized Steel Burners
- Non-Linting Pilot Burner
- Heater Cover Plates (for boilers with tankless heater openings)
- Control Wire
- Electrical Junction Box

EG/PEG boilers add:

- Combination Gas Valve for 24 volt
- Thermocouple (high efficiency models)
- Rollout Thermal Fuse Element
- Spill Switch
- Highest Efficiency Models, PID Intermittent Electronic Ignition System and Automatic Vent Damper
- High Efficiency Models, SPD Constant Burning, Thermally Supervised Pilot System and Automatic Vent Damper

For EG water boilers

- Built-In Air Eliminator
- 30 P.S.I. Relief Valve
- Combination Pressure Temperature Gauge
- High-Limit Control
- 40 VA Transformer with Receptacle for Circulator Relay
- Circulator Relay

For EG/PEG steam boilers

- Relief Valve
- Steam Pressure Gauge
- High-Limit Pressure Control
- Syphon
- Gauge Cocks
- Gauge Glass
- Low-Water Cutoff
- 40 VA Transformer

EG additional equipment

- Tankless Water Heater (EG-35 – 65 PI and SP; EG-75 PI only)
With tankless heater: Combination High Limit, Low Limit, Circulator Control, and Relay with 40 VA Transformer
- Tankless Steam Heater (EG-35 – 75)
With Tankless Heater: Operating Control and Tankless Heater 35-S-29 for All Units

EGH boilers add:

- Combination Gas Control Valve (includes main gas valve with redundant seat, PI and PI with damper models; main gas valve with single seat, 24V models; pressure regulator, gas cock, pilot filter, pilot adjustment)
- Highest Efficiency Models, PI Intermittent Electronic Ignition System
- High Efficiency Models, SP Constant Burning, Thermally Supervised Pilot System, Thermocouple
- 100% Shutoff
- 40 VA Transformer with Receptacle for Circulator Relay

For EGH water boilers

- Built-in Air Eliminator
- 30 P.S.I. Relief Valve
- Combination Pressure-Temperature Gauge
- High-Limit Control for PI and PI with Damper Models
- Dual-Limit Control for Standard Efficiency Models
- Circulator Relay

For EGH steam boilers

- Relief Valve
- Steam Pressure Gauge
- High-Limit Pressure Control (two limit controls on EGH-85 and 95 SP)
- Syphon
- Gauge Cocks
- Gauge Glass
- Low-Water Cutoff – Probe Type

EGH additional equipment

- Tankless Heaters – PI Water or Steam, SP Steam only
- With Tankless Heater(s):
 - Operating Control
 - Automatic Vent Damper



Weil-McLain
500 Blaine Street
Michigan City, IN 46360-2388
<http://www.weil-mclain.com>