

LINO EAF-200

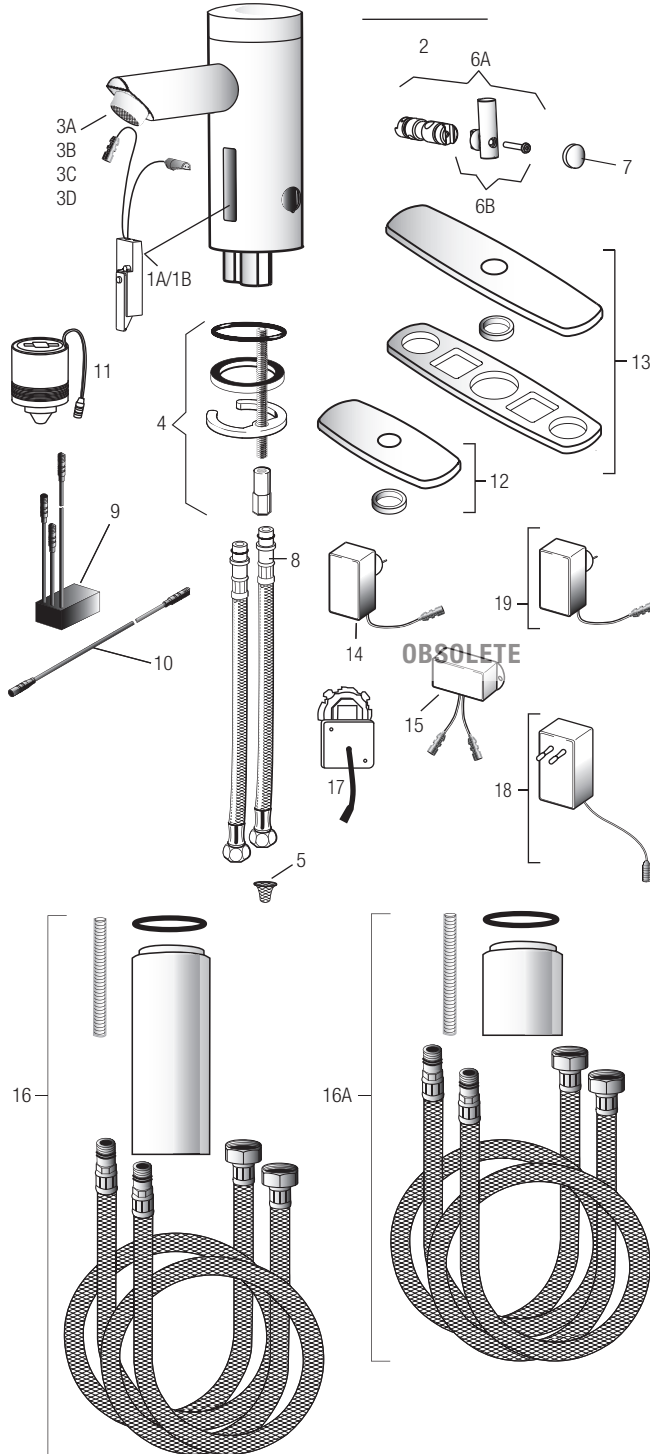

EAF-200 Series Faucet date code 1101 and newer. Product revised to make spray head vandal resistant without need for special spray. EAF-15 only works on product date code 1052 and older.



PARTS LIST—EAF-200 FAUCETS

Item No.	Code No.	Part No.	Description
1A.	0335016	EAF-18-A	Faucet Sensor Assembly with i.q.-cliq
1B.	0335017	EAF-19-A	Faucet Sensor Assembly without i.q.-cliq
2.	0335027	EAF-27	Cap
3A.	0335012	EAF-15	0.5 gpm (1.9 Lpm) VR Aerator Spray Head – Pre-03/2011
3B.	0335008	EAF-10	2.2 gpm (8.3 Lpm) Aerator Spray Head
3C.	0335011	EAF-13	2.2 gpm (8.3 Lpm) Laminar Flow Spray Head
3D.	0335029	EAF-51	0.35 gpm (1.3 Lpm) Multi-Laminar Spray Head
4.	0335000	EAF-1	Faucet Mounting Kit
5.	0335007	EAF-9	Strainer (Filter)
6A.	0335019	EAF-1004	Mixer Handle Assembly and Cartridge
6B.	3335020	EAF-1005	Handle Repair Kit
7.	3335022	EAF-1007	Handle Cap
8.	3335023	EAF-1008	13" (330 mm) Flexible Supply Hose
9.	0335044	EAF-44	Power Splitter [†]
10.	0335024	EAF-24-A	11-13/16" (300 mm) Ext. Cable (Model EAF-200)
	0335025	EAF-25-A	47-1/4" (1200 mm) Ext. Cable (Model EAF-200)
	0335015	EAF-17-A	126" (3200 mm) Ext. Cable (Model EAF-200)
11.	0335001	EAF-2	Solenoid
12.	3365468	ETF-312-A	Trim Plate for 4" Centerset Sink
13.	3365024	ETF-510-A	Trim Plate for 8" Centerset Sink
14.	0335009	EAF-11	(Model EAF-200) 90-264 VAC/6.75 VDC Plug-In Adapter (US)
15.	0335028	EAF-28	Capacitor Box (Model EAF-200) – OBSELETE
16.	3335035	EAF-35-A	Faucet Extension Kit
16A.	3335046	EAF-40-A	2-1/4" Faucet Extension Kit. Raises faucet such that outlet height complies with California Office of Statewide Health Planning and Development
17.	0335037	EAF-37	6 VDC Box Mount Voltage Adapter
18.	0335038	EAF-38	90-264 VAC/6.75 VDC Plug-In Adapter (EURO)
19.	0335039	EAF-39	90-264 VAC/6.75 VDC Plug-In Adapter (UK)

[†]EAF-44 replaces the separate EAF-23-A Splitter Cable and EAF-28 Capacitor, which is sold separately.

i.q.-cliq SETTINGS

Function	Press Button	LED Signal
Continuous Run – 2 minute default setting (adjustable from 1 – 20 minutes)	1 time for 2 seconds	5 short flashes
reset:	1 time or will reset automatically after 2 minutes	
Temporary Off	2 times (double click) by periodic flashing	5 short flashes followed
reset:	1 time or will reset automatically after 2 minutes	
Auto Set Range Adjustment	2 times (double click) and then 1 time for 5 seconds	5 short flashes followed by 4 short flashes

Electrical Connection for up to Six (6) Faucets Using One (1) Adapter

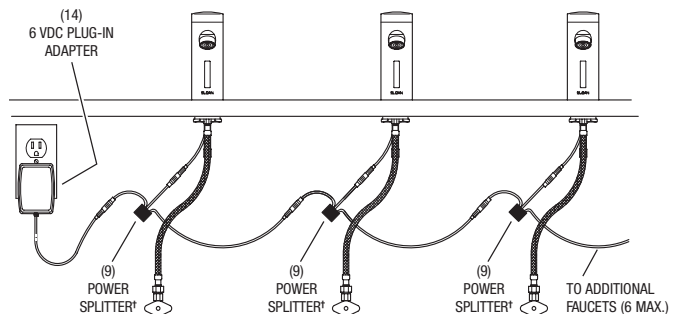

Faucets and Soap Dispensers

LINO EAF-200

TROUBLESHOOTING GUIDE

1. Faucet DOES NOT function.

- A. "Permanent Off" activated. Press button on faucet throat one time.

2. Faucet delivers water in an uncontrolled manner.

- A. Faucet is not working properly. Contact Sloan Technical Support.

3. Faucet DOES NOT deliver any water when Sensor is activated.

INDICATOR: Solenoid valve produces an audible "CLICK."

- A. Water supply stop(s) closed. Open water supply stop(s).
 B. Water supply stop strainer(s) clogged. Remove, clean, and reinstall water supply stop strainer(s). Replace strainer(s) if required.

INDICATOR: Solenoid valve DOES NOT produce an audible "CLICK."

- A. Power failure (EAF-200 Models). Check power supply.

4. Faucet delivers only a slow flow or dribble when sensor is activated.

- A. Water supply stop(s) are partially closed. Completely open water supply stop(s).
 B. Water supply stop strainer(s) clogged. Remove, clean, and reinstall water supply stop strainer(s). Replace strainer(s) if required.
 C. Aerator is clogged. Remove, clean, and reinstall Aerator. Replace Aerator if required.
 D. Faucet is not working properly. Contact Sloan Technical Support.

5. Faucet DOES NOT stop delivering water or continues to drip after user is no longer detected.

- A. Faucet is not working properly. Contact Sloan Technical Support.

6. The water temperature is too hot or too cold on a faucet connected to hot and cold supply lines.

- A. Supply Stops are not adjusted properly. Adjust Supply Stops.
 B. For models with integral mixing valve – Mixing valve is set improperly for the water temperature desired. Rotate mixing valve handle clockwise to decrease water temperature or counterclockwise to increase water temperature.

OPERATION

As the user's hands enter the beam's effective range, the beam is reflected back into the sensor receiver and activates the solenoid valve allowing water to flow from the faucet. Water will flow until the hands are removed or until the faucet reaches its automatic time out limit setting.

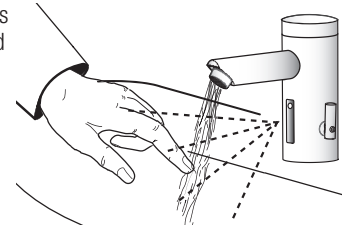

CARE AND CLEANING INSTRUCTIONS

DO NOT USE abrasive or chemical cleaners including chlorine bleach) to clean faucet that may dull the luster and attack the chrome or special decorative finishes. Use **ONLY** mild soap and water, then wipe dry with clean cloth or towel.

While cleaning the bathroom tile, protect the faucet from any splattering of cleaner. Acids and cleaning fluids will discolor or remove chrome plating.

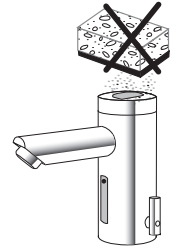

When assistance is required, please contact Sloan Technical Support at: 1-888-SLOAN-14 (1-888-756-2614).