

Optima® ETF-600/ETF-610



ETF-610



ETF-600

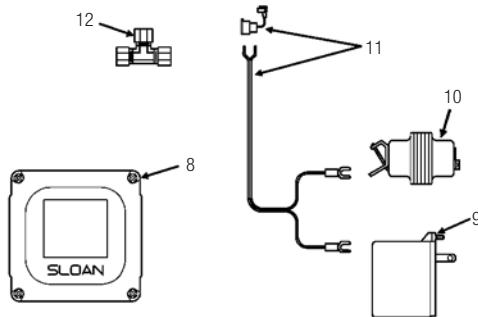
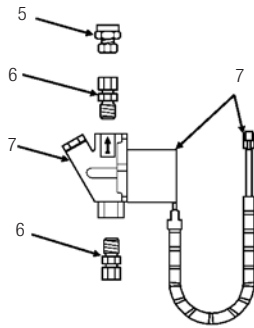
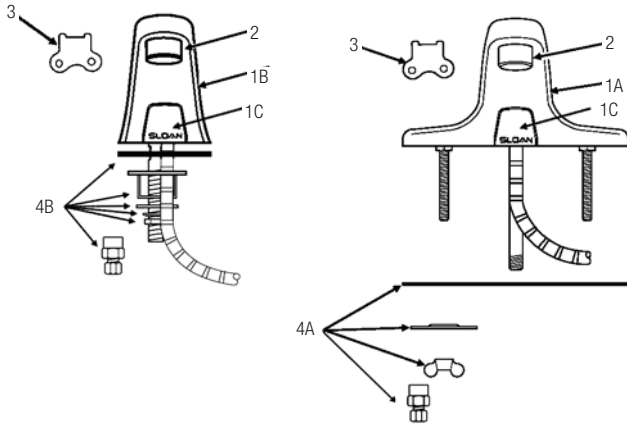

PARTS LIST—ETF-600 AND ETF-610 FAUCETS

Item No.	Code No.	Part No.	Description
1A.	0365086	ETF-543-A	Faucet and Sensor Assembly (ETF-600)
1B.	0365117	ETF-570-A	Pedestal Faucet and Sensor Assembly (ETF-610)
1C.	0365070	ETF-542-A	Sensor Module Only (for ETF-600 and ETF-610 faucets) includes 18" (153 mm) armored Cable, Shroud, and Housing for Sensor Window
2.	3365092	ETF-1023-A	0.5 gpm (1.9 Lpm) Spray Head with Key (male thread)
	3365093	ETF-1024-A	2.2 gpm (8.3 Lpm) Aerator Spray Head with Key (male thread)
	3365162	ETF-1029-A	2.2 gpm (8.3 Lpm) Laminar Flow Spray Head with Key (male thread)
	3365756	ETF-1039-A	0.35 gpm (1.3 Lpm) Multi-Lam Spray Head VR
3.	0305927	ETF-435	Replacement Key Only
4A.	3365088	ETF-546-A	Faucet Mounting Kit for ETF-600 includes Base Gasket, two (2) Slotted Mounting Washers, two (2) Wing Nuts, and Compression Fitting Connector
4B.	0315085	EBF-123-A	Faucet Mounting Kit for ETF-610 includes Spacer, Base Gasket, 1/4" NPSM Hex Nut, Washer, 9/16" Lock Washer and Compression Fitting Connector
5.	0365058	ETF-547	1/8" NPT Pipe to 3/8" Tube Compression Fitting Connector (female)
6.	3365676	ETF-437-A	Single Solenoid Supply Kit includes, two (2) Compression Fittings, Compression Nut, and Ferrule
7.	0305849	ETF-370-A	24 VAC Solenoid Valve Assembly includes 18" (457 mm) armored Cable and two (2) Terminal Housings
—	3305577	ETF-1009-A	Solenoid Valve Repair Kit includes Replacement Filter, Guide, Armature Spring, Diaphragm and Washer
8.	3365000	ETF-450-A	Control Module Assembly includes splashproof Junction Box and Junction Box Mounting Kit
9.	0365534	ETF-233	120V/35VA Plug-In Transformer
10.	0345370	EL-248-40	24V/40VA Box Mount Transformer
11.	0365001	ETF-458-A	Input Power Cable (Transformer to Control Module) includes Strain Relief and two (2) Terminal Crimp Connectors
12.	3365461	ETF-617-A	Bak-Chek® "T" Assembly

See page 157 for faucet cable extension cords.

— = Not shown in illustration

Optima® ETF-600/ETF-610**TROUBLESHOOTING GUIDE****1. No water is delivered when faucet is activated.****INDICATOR: If no LED lights illuminate:**

- A. No electricity is being supplied to faucet.
Ensure that the main power is turned "ON". Check all transformer, sensor, solenoid and cable connections. Make sure that transformer is supplying 24 VAC (Volts AC). If no voltage is detected, replace transformer.
- B. There is an electrical system malfunction.
Reset electrical system. Unplug Sensor connection. Disconnect power to circuit for ten (10) seconds. Reconnect.

INDICATOR: If the GREEN LED illuminates when power is reconnected:

- C. There is a short in the Sensor.
Replace sensor. Refer to individual faucet parts diagram for appropriate sensor assembly. Note: GREEN LED may illuminate immediately after sensor disconnection.
- D. There is a short in the solenoid or solenoid cable.
Replace ETF-370-A solenoid.

INDICATOR: If the GREEN LED does NOT illuminate when power is reconnected:

- E. There is an electrical system malfunction.
Reset electrical system. Unplug sensor connection. Disconnect power to circuit for ten (10) seconds. Reconnect.
- F. The control module circuit is not working properly.
Replace ETF-450-A control module.

INDICATOR: If GREEN LED illuminates AND changes to RED when hands are in the sensor's detection zone AND the RED solenoid LED illuminates:

- G. Water supply stop(s) may be partially closed.
Open stop(s) if closed.
- H. Debris is clogging solenoid filter.
Shut off water supply. Remove, clean and reinstall solenoid filter.

INDICATOR: If GREEN LED illuminates AND changes to RED when hands are placed in the sensor's detection zone AND the RED solenoid LED flickers with a vibrating/clicking noise heard inside the module: Note: Applies only to REVISION 2 MODULES.

- I. There is a direct short in the solenoid or solenoid cable.
Replace with ETF-370-A solenoid.

INDICATOR: If GREEN/RED LED illuminates AND changes to RED when hands are NOT located in the sensor's detection zone BUT the RED solenoid LED (in upper left corner of circuit) does NOT illuminate:

- J. Sensor range is set too long and is detecting the sink.
Reduce sensor detection range.
- K. Sensor is not working properly.
Replace sensor. Refer to individual faucet parts diagram for appropriate sensor assembly.

INDICATOR: If GREEN LED illuminates BUT does NOT change to red when hands are placed in the sensor's detection zone:

- L. Sensor range is set too short.
Increase sensor detection range.
- M. Sensor is not working properly.
Replace sensor. Refer to individual faucet parts diagram for appropriate sensor assembly.

2. Sensing range is too short.

- A. Extended range sensitivity is required.
Dip switch number 4 should be in the "DOWN" (Extended range sensitivity) position. Increase range by adjusting range potentiometer clockwise (yellow phillips screw in blue base).
- B. Faucet has surgical bend gooseneck spout.
For long range use (recommended for surgical bend gooseneck spout faucet models), remove range jumper from upper right hand corner of circuit board. Adjust range potentiometer. Note: Applies only to REVISION 2 MODULES.

3. Faucet activates by itself (false triggers).

- A. Sensor range is set too long.
Decrease range by adjusting range potentiometer counterclockwise. If necessary, flip dip switch number 4 into the "UP" (reduced range sensitivity) position. Check surroundings for factors that contribute to sensor range detection problems (bright lights, highly reflective surfaces, sunlight, etc.).

4. Faucet delivers very low flow or just a dribble.

- A. Water supply stop(s) may be partially closed.
Open stop(s).
- B. Debris is clogging solenoid filter.
Shut off water. Remove, clean, and reinstall solenoid filter.
- C. Solenoid is worn or not working properly.
Rebuild with ETF-1009-A solenoid repair kit or replace ETF-370-A solenoid.
- D. Debris is clogging faucet aerator or spray head.
Shut off water. Use key if required to remove. Then clean and reinstall aerator or spray head.

5. Faucet does not stop delivering water or continues to drip after user is no longer detected (even after power to the module has been disconnected).

- A. Solenoid valve is installed backward.
Disconnect solenoid. Reconnect solenoid with water flow towards the faucet (see arrow on solenoid).
- B. Debris is clogging solenoid.
Remove and clean solenoid operator. If necessary, rebuild with ETF-1009-A repair kit.
- C. Seat in solenoid valve body is damaged or pitted.
Replace with ETF-370-A solenoid.

When assistance is required, please contact Sloan Technical Support at: 1-888-SLOAN-14 (1-888-756-2614).