

4

3

2

1

BILL OF MATERIAL (CURRENT LEVEL)

ITEM	PT/ASSY	DESCRIPTION	TYPE	QTY.
1	8-072	ESCUTCHEON ASM	ASSEMBLY	1
2	8-074	WALL LAV SPOUT ASM	ASSEMBLY	1
3	3-426	FLOW CONTROL HANDLE	ASSEMBLY	2

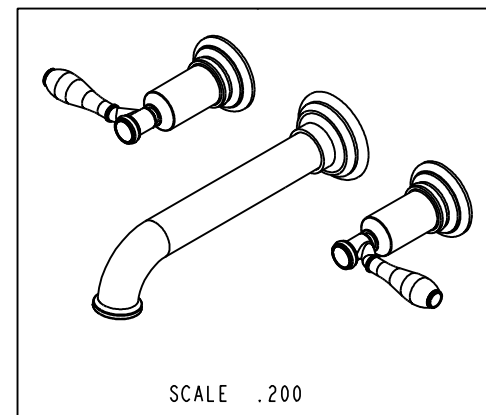
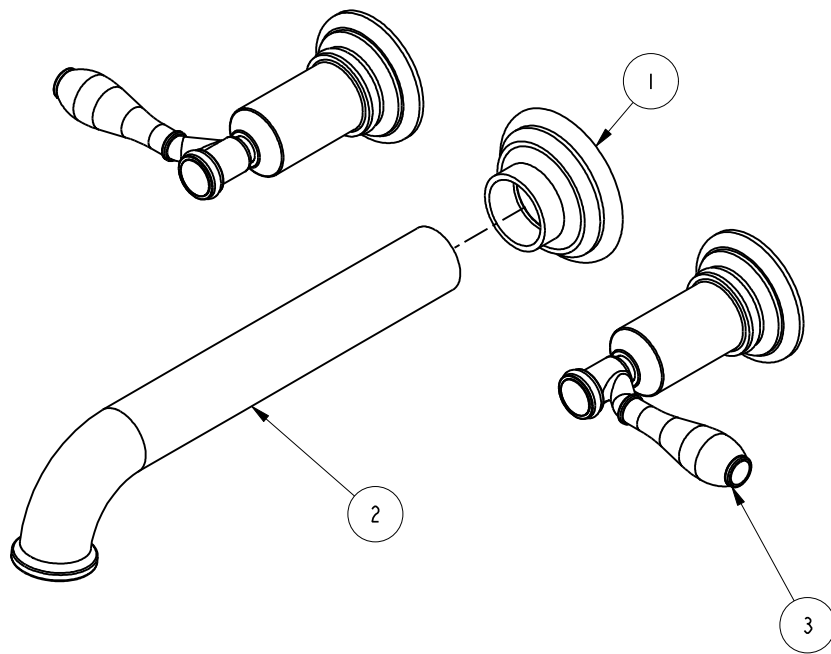

COPYRIGHT 2005 BRASSTECH, INC. THESE DRAWINGS AND THE DESIGNS DEPICTED HEREIN ARE THE PROPRIETARY PROPERTY OF BRASSTECH. ANY USE OR REPRODUCTION IS SUBJECT TO THE EXPRESS APPROVAL OF BRASSTECH. UNAUTHORIZED USE IS STRICTLY PROHIBITED. ALL RIGHTS RESERVED.

BRASSTECH
 INCORPORATED
 2001 E. CARNEGIE AVE.
 SANTA ANA, CA 92705
 (949) 417-5207

W/M LAVATORY FAUCET

ASSY. NO. 3-2551		-	-	-
SCALE .350	REF. -	SHEET 1 OF 4	REV	REV DESC
			EN-1735	06/10/11
				DATE

4

3

2

1

4 3 2 1

↓

SPECIFICATION DWG

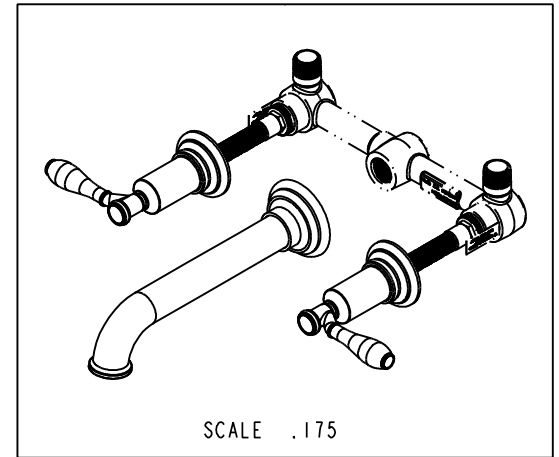
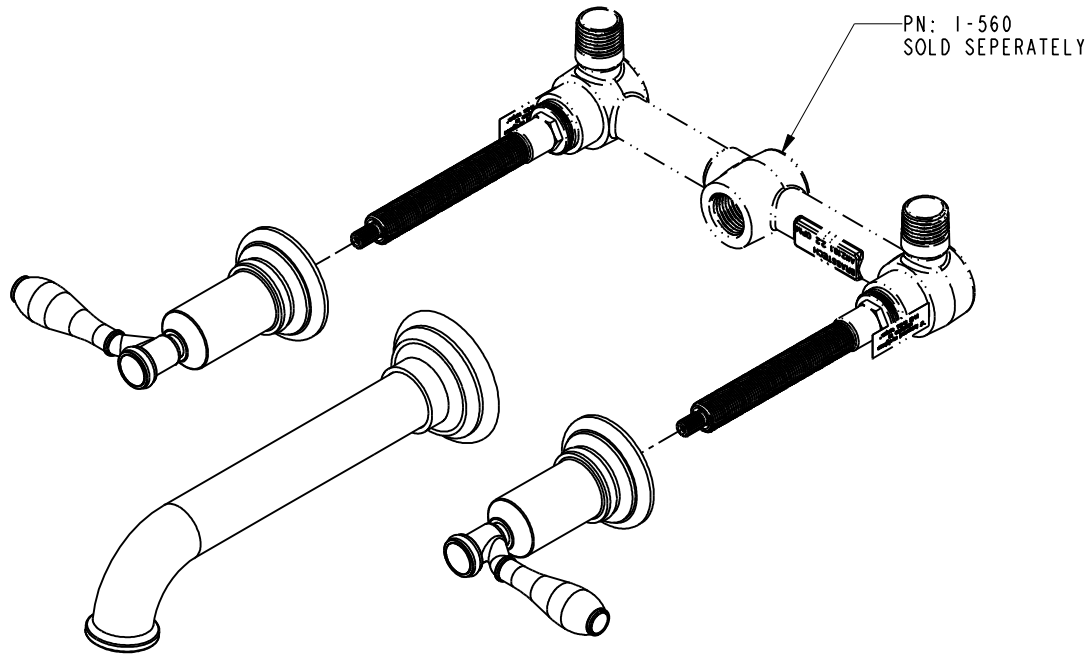

DIMENSIONS ARE IN INCHES AND AN APPROXIMATION OF A TYPICAL INSTALLATION

COPYRIGHT 2005 BRASSTECH, INC. THESE DRAWINGS AND THE DESIGNS DEPICTED HEREIN ARE THE PROPRIETARY PROPERTY OF BRASSTECH. ANY USE OR REPRODUCTION IS SUBJECT TO THE EXPRESS APPROVAL OF BRASSTECH. UNAUTHORIZED USE IS STRICTLY PROHIBITED. ALL RIGHTS RESERVED.

BRASSTECH		2001 E. CARNEGIE AVE.	
INCORPORATED		SANTA ANA, CA 92705	
		(949) 417-5207	
DWG NO.	3-2551	REF.	REV -
SCALE .300	REF. -	SHEET 2 OF 4	

D

C

B

A

D

C

B

A

SPECIFICATION DWG

NOTES:

- 1 CUT STEM TO DIMENSION SHOWN.
- 2 CUT ALL-THREAD 5/8" SHORTER THAN STEM.
- 3. VALVE, PN: 1-560, SOLD SEPERATELY.

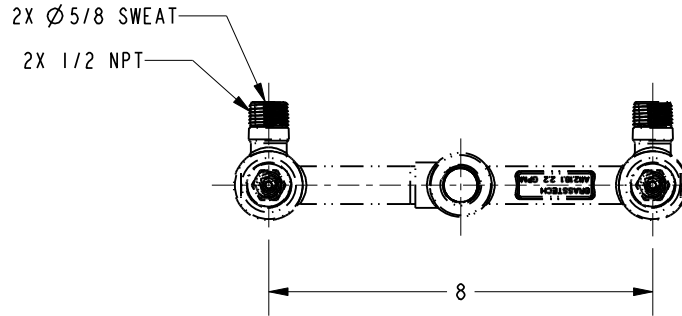
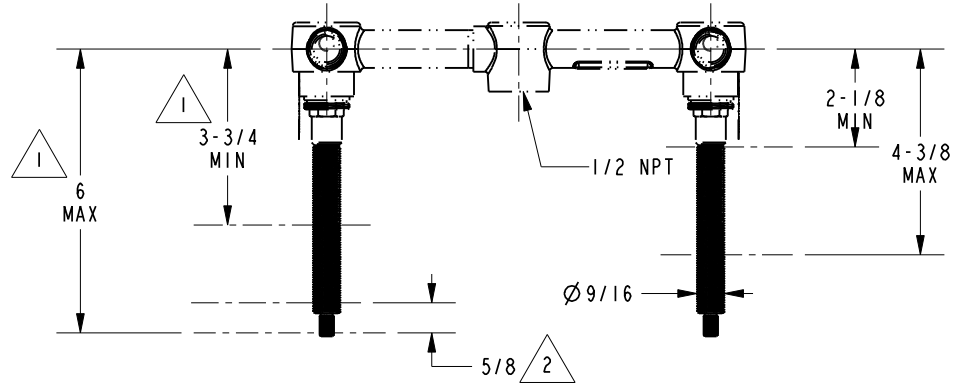
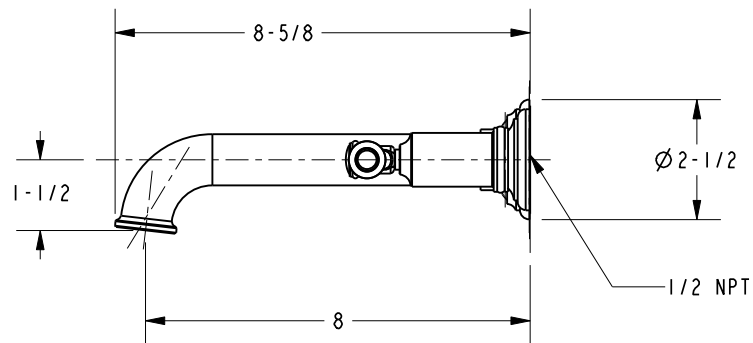
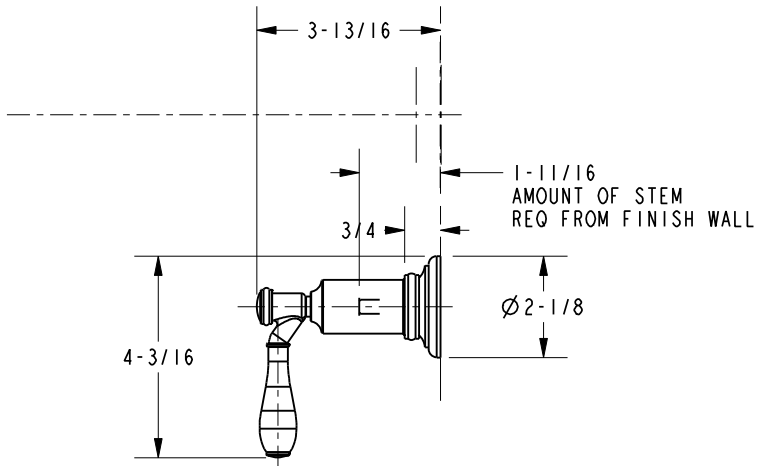

DIMENSIONS ARE IN INCHES AND AN APPROXIMATION OF A TYPICAL INSTALLATION

COPYRIGHT 2005 BRASSTECH, INC. THESE DRAWINGS AND THE DESIGNS DEPICTED HEREIN ARE THE PROPRIETARY PROPERTY OF BRASSTECH. ANY USE OR REPRODUCTION IS SUBJECT TO THE EXPRESS APPROVAL OF BRASSTECH. UNAUTHORIZED USE IS STRICTLY PROHIBITED. ALL RIGHTS RESERVED.

BRASSTECH		2001 E. CARNEGIE AVE. SANTA ANA, CA 92705 (949) 417-5207	
DWG NO.	3-2551	REV	-
SCALE	.250	REF.	-
		SHEET	3 OF 4