

BILL OF MATERIAL (CURRENT LEVEL)				
ITEM	PT/ASSY	DESCRIPTION	TYPE	QTY.
1	3-360	WIDE SPREAD SPOUT ONLY	ASSEMBLY	1
2	10048	ESCUTCHEON W/S VALVE	PART	2
3	10289	POP-UP KNOB	PART	1
4	10288	3/16" POP UP ROD	PART	1
5	10523	HEX ESCUTCHEON BONNET	PART	2
6	2-114	THIN BLADE X - HANDLE HOT	ASSEMBLY	1
7	2-115	THIN BLADE X - HANDLE COLD	ASSEMBLY	1
8	325	POP UP ASSEMBLY	ASSEMBLY	1
9	1-525	W/S VALVE INSTALLATION	ASSEMBLY	1
10	98037	STICKER LABEL A112.18.1	PART	1

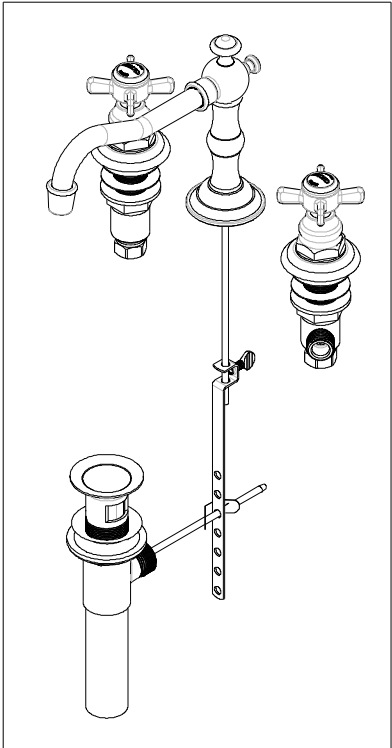

COPYRIGHT 2005 BRASSTECH, INC. THESE DRAWINGS AND THE DESIGNS DEPICTED HEREIN ARE THE PROPRIETARY PROPERTY OF BRASSTECH. ANY USE OR REPRODUCTION IS SUBJECT TO THE EXPRESS APPROVAL OF BRASSTECH. UNAUTHORIZED USE IS STRICTLY PROHIBITED. ALL RIGHTS RESERVED.

**BRASSTECH**  
INCORPORATED  
2001 E. CARNEGIE AVE.  
SANTA ANA, CA 92705  
(949) 417-5207

WIDE SPREAD WITH BLADE X - HDL

ASSY. NO. 1000

SCALE 0.250

REF. -

SHEET 1 OF 2

B	EN-1616	09/13/10
A	EO-1051	07/28/08
-	RELEASED	PRE '95
REV	REV DESC	DATE