



Franklin Electric

# WJC/JPC Convertible Jet Pump OWNER'S MANUAL

## SAFETY WARNINGS



**BEFORE OPERATING OR INSTALLING THIS PUMP, READ THIS MANUAL AND FOLLOW ALL SAFETY RULES AND OPERATING INSTRUCTIONS.**

### SAFETY:

READ THIS MANUAL BEFORE INSTALLING OR OPERATING THE PUMP.

### CAUTION:

Review instructions before operating.

### WARNING - ELECTRICAL PRECAUTIONS:

All wiring, electrical connections, and system grounding must comply with the National Electrical Code (NEC) and with any local codes and ordinances. Employ a licensed electrician.

### FOR DUAL-VOLTAGE MOTORS:

Voltage change instructions are located on motor label or on wiring access cover.

### WARNING - RISK OF ELECTRICAL SHOCK:

- Have an electrician provide electrical power to motor.
- A ground fault interrupter (GFI) protected circuit is recommended for use with any electrical device operating near water.
- For recommended cable size see Table 2 Maximum Wire Length.
- Motor must be grounded and terminal cover in place to reduce electrical shock hazard.
- Keep motor operating area as dry as possible.
- Always disconnect power before servicing.
- Not investigated for use in swimming pool area.

## APPLICATION

The convertible jet pump is ideal for the supply of fresh water to rural homes, farms and cabins that have suction lifts down to 90 ft. This pump may be installed as a shallow well unit with the injector mounted to the casing. For a deep well unit, the injector is mounted in the well and either combination of venturi or nozzle may be used. For vertical lifts of 25 ft. (7.5m) or less\*, install as a shallow well unit (Fig. 1a) and for vertical lifts beyond 25 ft. (7.5m), install as a medium depth deep well or as a deep well unit (Fig. 1b). In offset installations, friction losses in the suction pipe must be taken into consideration (refer to Table 3, Friction Loss Chart). This pump is not tested for use in swimming pool areas.

\*Less at high altitudes.

## INSTALLATION

a) **Pump Location:** The pump should be installed in a clean, dry and ventilated location which provides adequate room for servicing and protection from freezing temperatures. It should be bolted to a good foundation, preferably concrete and provided with adequate drainage. Locating the pump as close as possible to the water source reduces the friction in the suction pipe and will give maximum capacities.

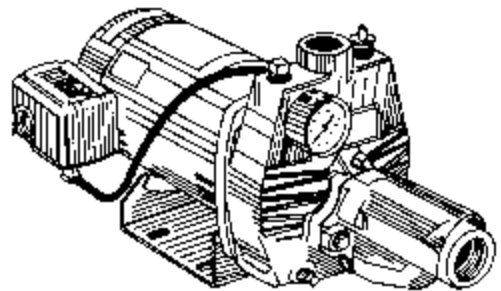

- b) **Suction & Pressure Pipe:** It is recommended that only new clean 1-1/4" pipe or hose be used. If the pump is installed any appreciable distance away from the source of water, the suction pipe should be increased to 1-1/2". Horizontal lengths of pipe must gradually slope upwards from the source of water to the pump to avoid air pockets in the line. Thread compound should be used on all pipe joints and connections should be thoroughly tightened. A foot valve must be installed and its operation should be checked since a leak will prevent proper operation of the system. Make sure the foot valve is located so that it will be submerged at all times. If the well cannot supply as much water as the pump can draw, install a tailpipe up to 30 ft long between the injector and the foot valve. As the well draws down under heavy demand, the pump's capacity will be reduced, and the level will not go below the foot valve, which would cause the pump to lose its prime. If a sandpoint or driven well is used, install a check valve next to the pump suction instead of the foot valve (Fig. 4b). All installations must have a foot valve or a check valve in the suction pipe.
- c) **Pump to Tank Fittings:** The discharge pipe from the pump to the tank should be as short and direct as possible and should be the same size as that of the pump discharge tapping. A check valve should never be installed between the pump and the tank.
- d) **Service Line:** The service line should be connected as shown in Fig. 4a, b, c or d. The size of the service line required is governed entirely by the amount of water needed and the length of the pipe. The pipe selected should be large enough so that the friction loss (determined from Table 3, Friction Loss Chart) will never exceed 20 ft. (6m) head.

Adhere to the guidelines of national, state and local plumbing codes when installing this product. Check with the appropriate agencies or water system professional for additional information.

### WARNING - ELECTRICAL PRECAUTIONS

All wiring, electrical connections, and system grounding must comply with the National Electrical Code (NEC) and with any local codes and ordinances. Employ a licensed electrician.

### WARNING - RISK OF ELECTRICAL SHOCK

e) **Wiring:** An electrician should be employed to do the wiring and connect the electrical service to the pump. The pressure switch is wired to the motor at the factory and the voltage, for which the motor is wired, is indicated by a sticker on the back of the motor. Make sure the motor is wired for the same voltage as the power supply. Refer to the motor nameplate or inside terminal cover for voltage changing instructions. The power lines should be connected to the pressure switch terminals marked "line" (see Fig. 2). It is recommended that a separate circuit be led from the distribution panel to the pump unit. A ground fault interrupter (GFI) protected circuit should be used for all electrical devices

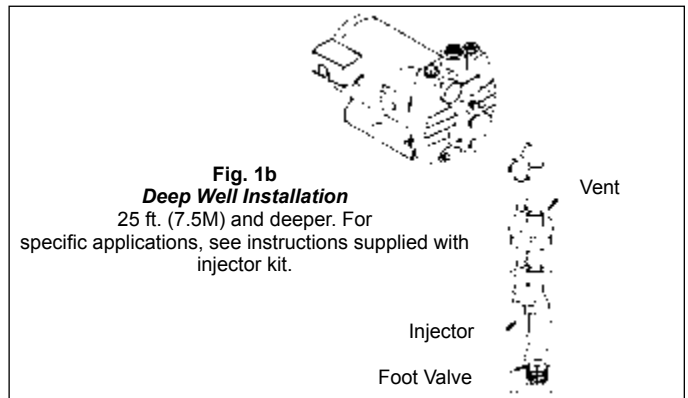
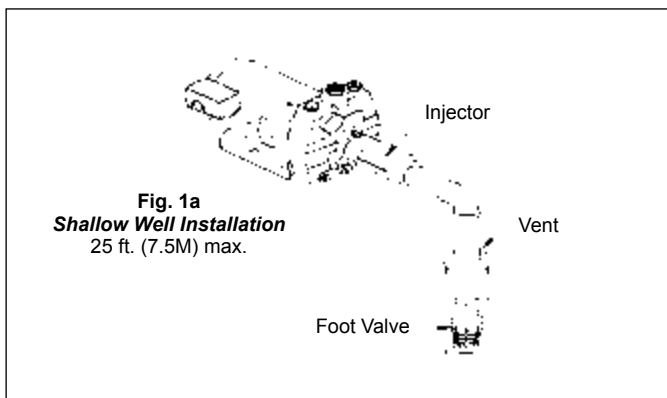

**TABLE 1 - PERFORMANCE**

HP	INJECTOR	DEPTH (IN FEET)													MINIMUM PSI	INJECTOR SETTINGS
		5	10	15	20	25	20	30	40	50	60	70	80	90		
		CAPACITY (IN GALLONS PER MINUTE @ 30 PSI DISCHARGE)														
SINGLE PIPE SHALLOW WELL INSTALLATION						DOUBLE PIPE DEEP WELL INSTALLATION										
1/2	SW	10.9	9.5	7.9	6.5	4.7	--	--	--	--	--	--	--	--	n/a	Mounted on pump
	DW (M)	--	--	--	--	--	11.3	9.4	7.6	--	--	--	--	--	25	45 feet
	DW	--	--	--	--	--	9.2	8.1	6.8	5.8	5.0	4.3	3.4	2.6	25	95 feet
3/4	SW	17.7	15.1	12.4	9.7	7.4	--	--	--	--	--	--	--	--	n/a	Mounted on pump
	DW (M)	--	--	--	--	--	14.7	12.3	9.7	--	--	--	--	--	25	45 feet
	DW	--	--	--	--	--	9.8	8.9	7.1	6.1	5.3	4.4	3.5	2.9	25	95 feet
1	SW	19.9	16.8	14.1	11.8	8.8	--	--	--	--	--	--	--	--	n/a	Mounted on pump
	DW (M)	--	--	--	--	--	16.2	13.5	11.0	--	--	--	--	--	25	45 feet
	DW	--	--	--	--	--	10.5	9.3	8.0	7.2	6.2	5.3	4.5	3.4	25	95 feet

SW - Shallow well      DW (M) - Deep well (medium)      DW - Deep well

operating near water. Install a proper fused disconnect switch in the line and make certain the wiring is adequately sized and well insulated. Undersized wire between the motor and the power source will adversely limit the starting and load carrying abilities of the motor. Minimum wire sizes for motor branch circuits are recommended (see Table 2). For added safety, the pump and motor should be grounded to the well casing if metal or the ground in the distribution panel.

- f) **Pressure Gauge:** If a pressure gauge is supplied with the pump or if you wish to install a pressure gauge, it should be installed into the 1/4" NPT hole on the front of the casing directly beside the discharge opening.
- g) **Air Volume Control:** If a non-diaphragm tank is used in the pressure system, an air volume control must be used to maintain an air cushion in the pressure tank. If not, air in the tank will gradually be absorbed by water, causing the tank to water log, and the pump to short cycle. This greatly shortens the life of the motor. An air volume control will provide the right air/water ratio and prevent water logging. Refer to pressure tank owner's manual for instructions.
- h) **Pressure Relief Valve:** A high pressure safety relief valve is recommended to be installed at some point in the water system. Ensure its location is near the discharge of the pump, in an area with adequate drainage. Be sure to direct the valve so that any water flow could not spray towards any electrical devices.

**OPERATION**

**⚠ WARNING: DO NOT RUN THE PUMP BEFORE PRIMING IT, SINCE THE SEAL AND IMPELLER COULD BE PERMANENTLY DAMAGED.**

**PRIMING:**

**Note:** You will need enough water to fill the suction line(s) and casing. Priming time depends on distance from water source to pump (5-15 minutes).

**Using an inline check valve:**

1. Open discharge valve on service line and nearby tap to monitor water flow.
2. Fully open control valve (counter-clockwise rotation).
3. Pour clean water through priming plug opening at top of casing until water starts flowing out.
4. Install enclosed priming plug, hand tighten.
5. Start pump. If a tap is visible, you may see a short discharge of water which will last 5-10 seconds.
6. Run the pump for two minutes and then shut it off. Remove priming plug.

7. You have completed the first priming cycle, consisting of steps 3 to 6. This process will have to be repeated from 2 to 6 times, depending on the length of your suction line (approximately one priming cycle for every 5 ft of suction line). You will know when to stop because the pump will begin to pump water continuously.
8. Once the pump begins pumping water continuously, firmly tighten the priming plug with a wrench.
9. Adjust the control valve (clockwise), so that the flow and pressure are stable. (see double pipe installation instructions)
10. If the pump does not draw water within 8 tries, shut it off and check for suction leaks.

**Using a foot valve:**

**SINGLE PIPE INSTALLATION**

11. Fill suction pipe with water prior to connecting piping to pump. You will need approximately 1 liter of water for every 3 ft. of suction line.  
**Note:** If you are unable to fill the suction line, please use the directions above for an inline check valve.
12. Follow steps 1 to 5 above. If within two minutes water is not being pumped continuously, stop the pump. Remove priming plug. Repeat steps 3 to 5 above. If this does not work, stop the pump and check the suction line for leaks.
13. Once the pump begins pumping water continuously, firmly tighten the priming plug with a wrench.

**DOUBLE PIPE INSTALLATION**

(Deep Well Application): Priming and setting the discharge control valve.

Follow the single pipe installation procedures. Close the control valve (clockwise rotation). If the pump is properly primed, pressure will build up immediately. Open the control valve slowly (approx. 1 to 2-1/2 turns) until the pump delivers maximum capacity as observed from an open tap nearest the pump. Observing the pressure gauge while the pump is pumping continue to adjust the control valve so that the pressure gauge reads approx. 25 PSI and flow and pressure is stable.

**DRAINING:**

Should the unit be subject to freezing, it will be necessary to drain the pump and tank. To do this, shut off the power to the pump at the main electrical panel. Open a tap in the water system to release the pressure. Remove the drain and priming plugs from the pump

**TABLE 2 – MAXIMUM WIRE LENGTH (FT.)**

HP	MOTOR Volts	WIRE GAUGE (AWG)				
		0-25 ft.	50 ft.	100 ft.	150 ft.	200 ft.
1/2	115	14	14	12	10	8
	230	14	14	14	14	14
3/4	115	14	14	10	8	8
	230	14	14	14	14	12
1	115	14	12	10	8	6
	230	14	14	14	14	12

Based on an approximate 3% voltage drop.

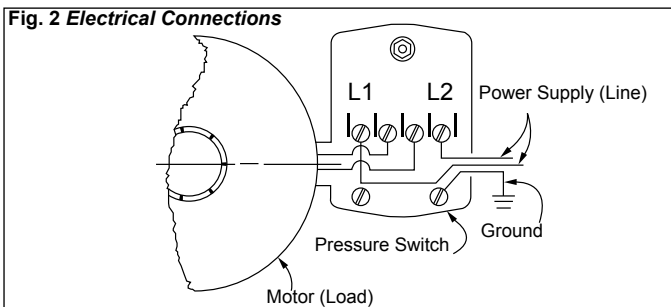

**MAINTENANCE**

**⚠ WARNING - RISK OF ELECTRICAL SHOCK**

Before servicing motor-operated equipment, shut off the power at the main electrical panel and disconnect the power supply from motor and accessories. Use safe working practices during servicing of equipment.

- a) Lubrication: The pump requires none. Refer to motor manufacturer's instructions.
- b) Replacing Mechanical Seal: (See Fig. 3)  
Only duly qualified persons should perform maintenance on electrical and/or mechanical devices.

**Disassembly:**

- 1) Shut off the power to the pump at the main service panel.
- 2) Open a tap in the water system to release the pressure.
- 3) Remove the drain (12) and prime plugs to allow the pump to drain.
- 4) Disconnect the tube leading to the pressure switch.
- 5) Remove the 4 bolts (1) and remove casing (2).
- 6) Pry the diffuser (4) out of the casing using two slotted screwdrivers for leverage.
- 7) Remove cap (5) and insert a screwdriver to prevent the shaft from turning while unscrewing the impeller (6) (GE motors). For A.O. Smith motors, remove rear cover and hold the shaft using a flat wrench inserted from the side, through the opening in the end of the housing. If the impeller cannot be turned by hand, insert a flat object into the impeller vane.
- 8) Slip the rotating seal (7) off the shaft and remove the seal plate (8).
- 9) Remove the ceramic seal seat (9) from the seal plate.

**Reassembly:**

- 1) Clean all the parts thoroughly before assembling.
- 2) Lightly lubricate (soapy water) the rubber cap on the ceramic seal (9) and push it into the seal plate using thumbs only. Make sure the smooth surface of the ceramic seat faces outwards.  
**Note:** If the pump will remain out of service for longer than one week, the seal components must be installed dry (no lubrication).
- 3) Put the seal plate back on the motor.
- 4) Lubricate the rotating seal (7) (soapy water) and slip it onto the shaft with the 'carbon' ring towards the ceramic seat.
- 5) Replace the impeller (6) and the diffuser (4).
- 6) Replace the casing (2) making sure the gasket is not damaged and is in place.
- 7) Reconnect the tubes to the casing and to the pressure switch.
- 8) Reconnect the power.
- 9) Prime pump, start, check for leaks.

**TROUBLESHOOTING**

- a) Motor will not start:
  - 1) No power to pressure switch due to blown fuses, open switches or loose connections.

- 2) Pump pressure switch not closed.
- b) Pump fails to deliver water:
  - 1) Pump not completely primed.
  - 2) Suction lift is too great.
  - 3) Foot valve is not submerged, buried in mud or plugged.
  - 4) Restrictor valve is fully closed.
- c) Pump loses prime:
  - 1) Air leaks in suction line.
  - 2) Well draws down too far and requires a tailpipe.
  - 3) Faulty foot valve.
- d) Pump delivers water but not at rated capacity:
  - 1) Leaks in suction or discharge line.
  - 2) Foot valve, suction line, impeller or nozzle are partially plugged.
  - 3) Suction lift is greater than recommended.
  - 4) Improper setting of control valve on deep well units.
  - 5) Improper impeller rotation or low speed.
  - 6) Motor is wired for improper voltage.
  - 7) Low line voltage at motor.
- e) Pump starts and stops too often:
  - 1) Air leak in tank above the water level.
  - 2) Incorrect setting on pressure switch.
  - 3) Tank is water logged or incorrectly charged.
  - 4) Foot valve leaks or is stuck open.

**TABLE 3 – FRICTION LOSS CHART FOR PLASTIC PIPE:**

For galvanized pipe, double the figures.

Loss of head in ft, due to friction per 100 ft of pipe

Nominal Pipe Size U.S. GPM	3/4"	1"	1 1/4"	1 1/2"	2"
4	3.74	1.15	0.30	0.14	–
5	5.66	1.75	0.46	0.22	–
6	7.95	2.45	0.65	0.31	–
7	10.60	3.25	0.86	0.41	–
8	13.50	4.16	1.10	0.52	–
9	16.80	5.17	1.35	0.65	–
10	20.40	6.31	1.67	0.79	0.23
11	24.40	7.58	1.98	0.95	0.27
12	28.60	8.85	2.33	1.10	0.32
14	38.00	11.80	3.10	1.46	0.43
16	48.60	15.10	3.96	1.87	0.55
18	60.50	18.70	4.93	2.33	0.69
20	73.50	22.80	6.00	2.83	0.84

Loss of head in meters, due to friction per 100m of pipe

Nominal Pipe Size l/min.	20mm	25mm	32mm	40mm	50mm
15	3.70	1.15	0.30	0.13	–
20	5.33	1.64	0.43	0.19	–
25	7.14	2.18	0.56	0.27	–
30	13.50	4.13	1.08	0.49	–
35	16.30	5.00	1.31	0.61	–
40	23.50	7.30	1.90	0.88	0.25
45	28.30	8.74	2.31	1.07	0.29
50	34.20	10.60	2.79	1.32	0.38
55	40.70	12.60	3.32	1.56	0.46
60	48.10	14.90	3.92	1.85	0.54
65	55.70	17.30	4.54	2.15	0.63
70	63.80	19.70	5.20	2.46	0.73
75	72.20	22.40	5.89	2.78	0.83

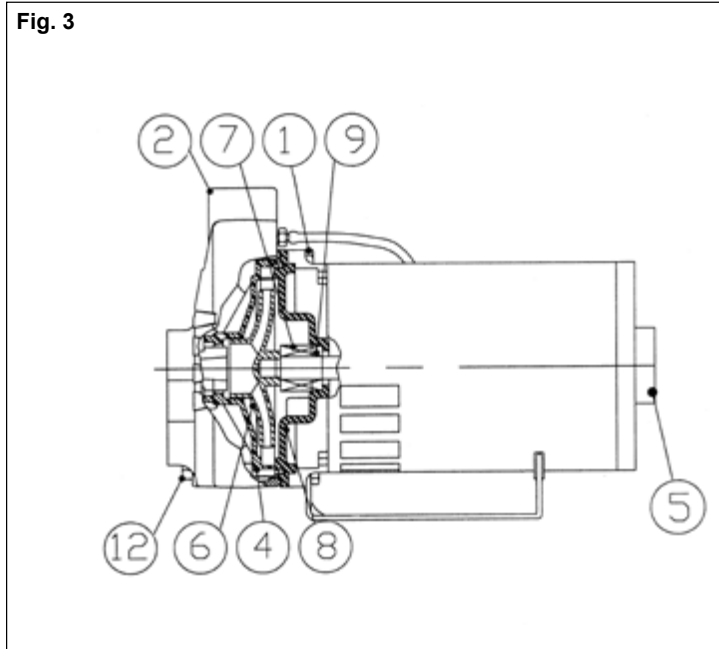

TYPICAL INSTALLATIONS

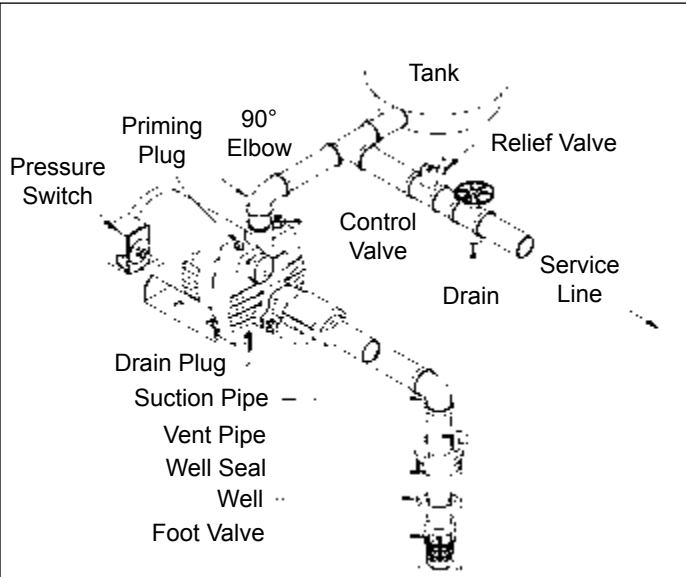

Fig. 4a SHALLOW WELL (WITH FOOT VALVE)

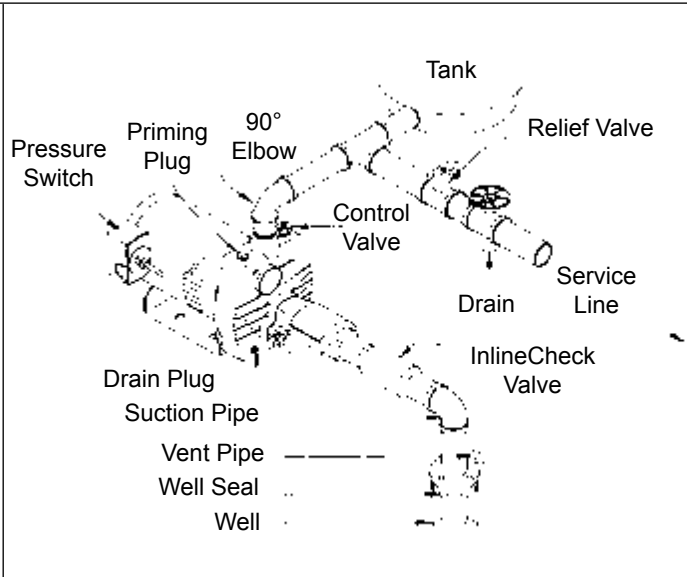

Fig. 4b SHALLOW WELL (WITH INLINE CHECK VALVE)

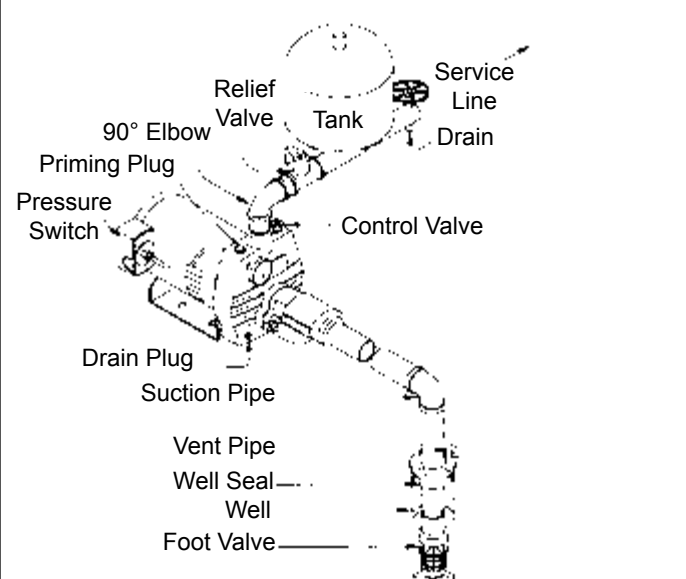

Fig. 4c SHALLOW WELL - INLINE TANK (WITH FOOT VALVE)

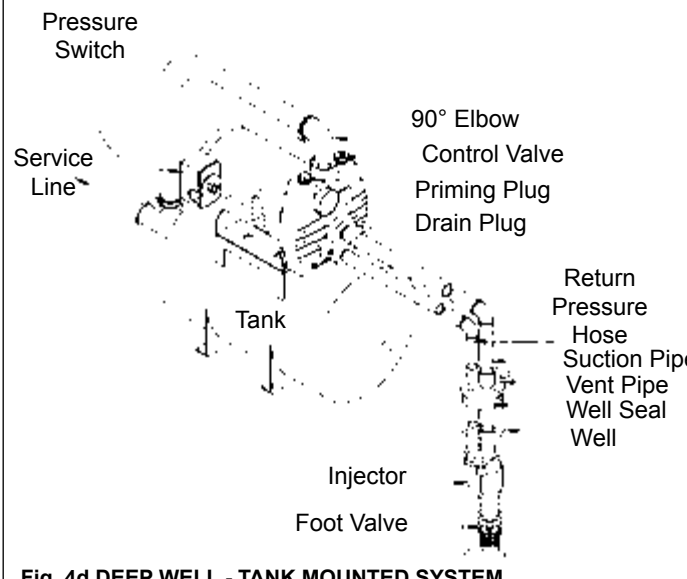
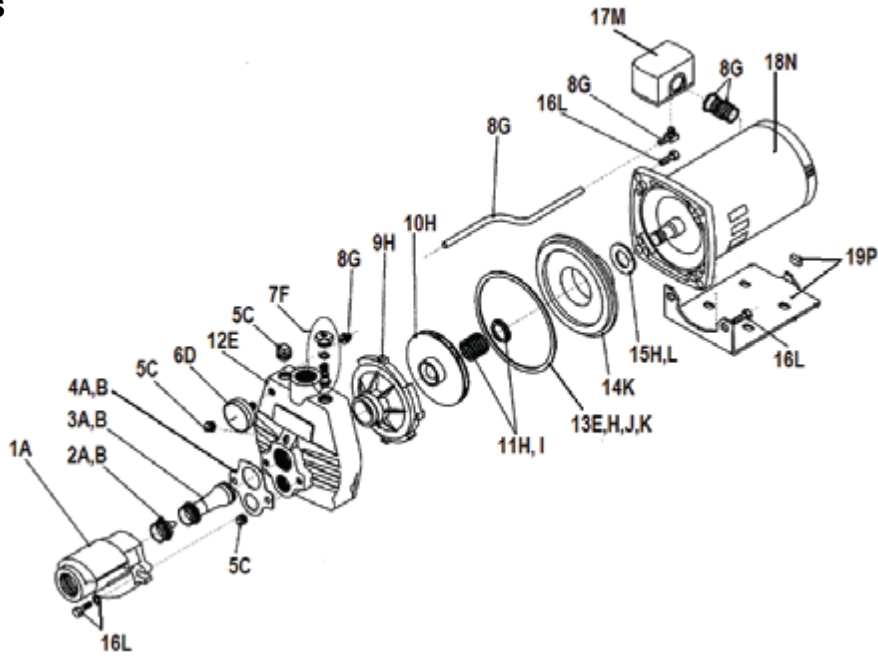

Fig. 4d DEEP WELL - TANK MOUNTED SYSTEM (DOUBLE PIPE INSTALLATION WITH FOOT VALVE)

# REPLACEMENT PARTS



Number	Description	Kit Grouping Identifier	Repair Part Order Codes by Model Number		
			1/2 hp	3/4 hp	1 hp
1	Injector body	A	305446946	305446947	
2	Nozzle	B	305446948	305446949	
3	Venturi	A	305446946	305446947	
4	Gasket, injector	B	305446948	305446949	
5	Plugs kit	C	305446953		
6	Pressure Gauge	D	305446935		
7	Valve assembly	F	305446951		
8	Switch attachment set	G	305446936		
9	Diffuser	H	305446941	305446942	
10	Impeller				
11	Mechanical Seal	I	106196221		
12	Casing	E	305446950		
13	Gasket	H	305446941	305446942	
		J	305446945		
		K	305446943		
14	Seal Plate	L	305446941	305446942	
15	Flinger				
16	Fastner Kit*	L	305446952		
17	Pressure Switch	M	305446944		
18	Motor	N	305446955	305446956	305446957
19	Base Assembly	P	305446960		

†Items with like identifiers are sold/packaged together.

\*Fastener kit (16L) is a complete set of the hardware used to assemble the pump. As a convenience, kit A,B,E,H,K contain the fasteners needed for the reassembly of its components.

# LIMITED WARRANTY\*

## **THIS WARRANTY SETS FORTH THE COMPANY'S SOLE OBLIGATION AND PURCHASER'S EXCLUSIVE REMEDY FOR DEFECTIVE PRODUCT.**

Franklin Electric Company, Inc. and its subsidiaries (hereafter "the Company") warrants that the products accompanied by this warranty are free from defects in material or workmanship of the Company.

The Company has the right to inspect any product returned under warranty to confirm that the product contains a defect in material or workmanship. The Company shall have the sole right to choose whether to repair or replace defective equipment, parts, or components.

The buyer should return the product to the place of purchase for warranty consideration. Subject to the terms and conditions listed below, the Company will repair or replace to the buyer any portion of this product which proves defective due to materials or workmanship of the Company.

The Company will consider products for warranty for 12 months from the date of installation or for 24 months from the date of manufacture, whichever occurs first.

The Company shall IN NO EVENT be responsible or liable for the cost of field labor or other charges incurred by any customer in removing and/or affixing any product, part or component thereof.

The Company reserves the right to change or improve its products or any portions thereof without being obligated to provide such change or improvement to previously sold products.

THIS WARRANTY DOES NOT APPLY TO products damaged by acts of God, including lightning, normal wear and tear, normal maintenance services and the parts used in connection with such service, or any other conditions beyond the control of the Company.

THIS WARRANTY WILL IMMEDIATELY VOID if any of the following conditions are found:

1. Product is used for purposes other than those for which it was designed and manufactured;
2. Product was not installed in accordance with applicable codes, ordinances and good trade practices;
3. Product was not installed by a Franklin Certified Contractor; or
4. Product was damaged as a result of negligence, abuse, accident, misapplication, tampering, alteration, improper installation, operation, maintenance or storage, nor to an excess of recommended maximums as set forth in the product instructions.

NEITHER SELLER NOR THE COMPANY SHALL BE LIABLE FOR ANY INJURY, LOSS OR DAMAGE, DIRECT, INCIDENTAL OR CONSEQUENTIAL (INCLUDING, BUT NOT LIMITED TO, INCIDENTAL OR CONSEQUENTIAL DAMAGES FOR LOST PROFITS, LOST SALES, INJURY TO PERSON OR PROPERTY, OR ANY OTHER INCIDENTAL OR CONSEQUENTIAL LOSS), ARISING OUT OF THE USE OR THE INABILITY TO USE THE PRODUCT, AND THE BUYER AGREES THAT NO OTHER REMEDY SHALL BE AVAILABLE TO IT.

THE WARRANTY AND REMEDY DESCRIBED IN THIS LIMITED WARRANTY IS AN EXCLUSIVE WARRANTY AND REMEDY AND IS IN LIEU OF ANY OTHER WARRANTY OR REMEDY, EXPRESS OR IMPLIED, WHICH OTHER WARRANTIES AND REMEDIES ARE HEREBY EXPRESSLY EXCLUDED, INCLUDING BUT NOT LIMITED TO ANY IMPLIED WARRANTY OF MERCHANTABILITY OR FITNESS FOR A PARTICULAR PURPOSE, TO THE EXTENT EITHER APPLIES TO A PRODUCT SHALL BE LIMITED IN DURATION TO THE PERIODS OF THE EXPRESSED WARRANTIES GIVEN ABOVE.

DISCLAIMER: Any oral statements about the product made by the seller, the Company, the representatives or any other parties, do not constitute warranties, shall not be relied upon by the buyer, and are not part of the contract for sale. Seller's and the Company's only obligation, and buyer's only remedy, shall be the replacement and/or repair by the Company of the product as described above. Before using, the user shall determine the suitability of the product for his intended use, and user assumes all risk and liability whatsoever in connection therewith.

Some states and countries do not allow the exclusion or limitations on how long an implied warranty lasts or the exclusion or limitation of incidental or consequential damages, so the above exclusion or limitations may not apply to you. This warranty gives you specific legal rights, and you may also have other rights which vary from state to state and country to country.

\*Contact Franklin Electric Co., Inc. Export Division for International Warranty.



**Franklin Electric**

400 E. Spring St, Bluffton, IN 46714  
Tel: 260-824-2900 Fax: 260-824-2909  
www.franklin-electric.com