

SUBMITTAL SHEET

JOB NAME	ITEM TAG
JOB LOCATION	PART NUMBER
CONTRACTOR	DATE
ENGINEER APPROVAL	DATE

RED TOP ECONOMY GAS BALL VALVE

T-3005

Ideal for all residential and commercial gas installations
 Chrome plated ball and soft seats resist contamination build-up and offer a positive seal in low- or moderate-pressure gas applications
 Quarter-turn, ball-type, forged brass design is more compact and superior to traditional cast bronze or cast iron gas cocks
 The 400 p.s.i. pressure rating permits high-pressure air tests, without the grease-seal blowout common to plug-type gas cocks

Working Pressure, Non Shock (PSI)

Cold working pressure (CWP): 400 PSI
 Saturated steam (WSP): Not Suitable for Steam Service

DIMENSIONS				
Size	A	B	C	D (Dia.)
1/2" FNPTx FNPT	2.17	1.22	1.14	0.39
3/4" FNPT x FNPT	2.44	1.38	1.14	0.59
1" FNPT xFNPT	2.87	1.65	1.57	0.79

MATERIAL SPECIFICATION		
PART	MATERIAL	SPECIFICATION
1 Handle screw	Zinc plated steel	AISI 1010
2 Handle	Coated zinc-aluminum	ASTM B86
3 Stem	Forged brass	ASTM B16 UNS C36000
4 Packing nut	Forged brass	ASTM B16 UNS C36000
5 Stem packing	PTFE	*Dupont Teflon™
6 Identification handle disc	Aluminum	ASTM B209-1100
7 Body	Forged brass	ASTM B124 UNS C37700
8 Seats (2)	PTFE	*Dupont Teflon™
9 Ball	Forged brass	ASTM B16 UNS C36000
10 End adapter	Forged brass	ASTM B124 UNS C37700

*Teflon is a registered trademark of DUPONT



CSA Certified for use with natural, manufactured or mixed liquefied petroleum and LP gas/air mixtures:

ANSI standard Z21.15 for use as a gas appliance connector valve for 1/2-lb. systems

CSA Certified 3-88 for use in 2 or 5 lb. house piping systems

UL listed for the sizes 1/2" and 3/4" within the following categories**:

YRPV.MH15973 Gas Shutoff Valves

MHKZ.MH15973 Manual Valves

VOGU.MH15973 Valves, Trim and Drain

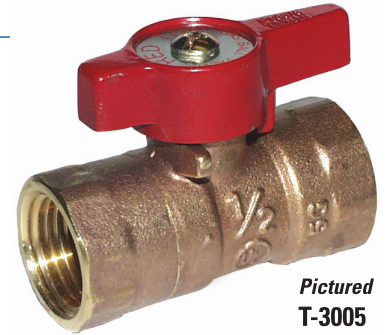

Pictured T-3005

**Reprinted from the Online Certifications Directory with permission from Underwriters Laboratories, Inc. Copyright © 2010 Underwriters Laboratories, Inc. ®

Massachusetts Commonwealth approved

Threaded end connections conform to ANSI / ASME B1.20.1

Manufactured in an ISO 9002 accredited facility

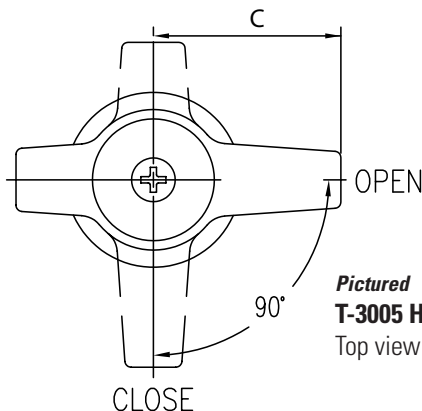

Pictured T-3005 Handle
Top view

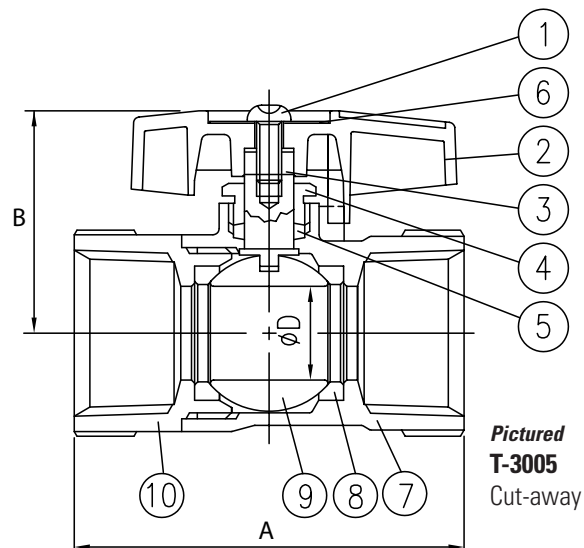

Pictured T-3005
Cut-away



T-3000 Blue Top One-Piece Forged Brass Gas Ball Valve FNPT x Texas Pattern (1/2" x 1/8" & 3/4" x 1/8")



T-3001 Blue Top One-Piece Forged Brass Gas Ball Valve with T-Handle FNPT x FNPT (3/8" - 2")



T-3002 Flat Head One-Piece Forged Brass Gas Valve Flathead FNPT x FNPT (1/2" & 3/4")



T-3100 Blue Top One-Piece Forged Brass Gas Valve with Sidetap For Testing FNPT x FNPT (1/2" - 1")



T-3100 Blue Top One-Piece Forged Brass Gas Valve with Sidetap Flare x Flare (3/8" & 1/2")

T-3005 Red Top™ Economy Gas Ball Valve

- Two-piece designed forged brass gas valve with coated zinc-aluminum cast handle. Manufactured in a ISO certified facility.
- CSA Certified for use with natural, manufactured or mixed liquified petroleum and LP gas/air mixtures:
ANSI standard Z21.15 for use as a gas appliance connector valve for 1/2 lb. systems.
CSA Certified 3-88 for use in 2 or 5 lb. house piping systems.
- UL Listed for the sizes 1/2" and 3/4":
YRPV.MH15973 gas shutoff valves
MHKZ.MH15973 manual valves
VQGU.MH15973 valves, trim and drain
Massachusetts Commonwealth approved
- Threaded end connections conform to ANSI/ASME B1.20.1
- Saturated Steam (WSP): not suitable for steam service.
- Cold working pressure (CWP): 400 PSI



FNPT x FNPT (1/2", 3/4" & 1")