

ELKAY *With FLEXI-GUARD®*

INSTALLATION, CARE & USE MANUAL



Manual de Instalación, Cuidado y Utilización
Manuel d'installation/entretien/utilisation

EZ™ & LZ™ Series Bottle Filling Stations & Coolers

EZ™ & LZ™ Serie Botella Bombas y Enfriadores

EZ™ & LZ™ Stations de Remplissage de Bouteille Série et Refroidisseurs



Pictured is unit only without bottle filler.

Uses HFC-134A refrigerant
 Usa refrigerante HFC-134A
 Utilise du fluide frigorigène HFC-134A

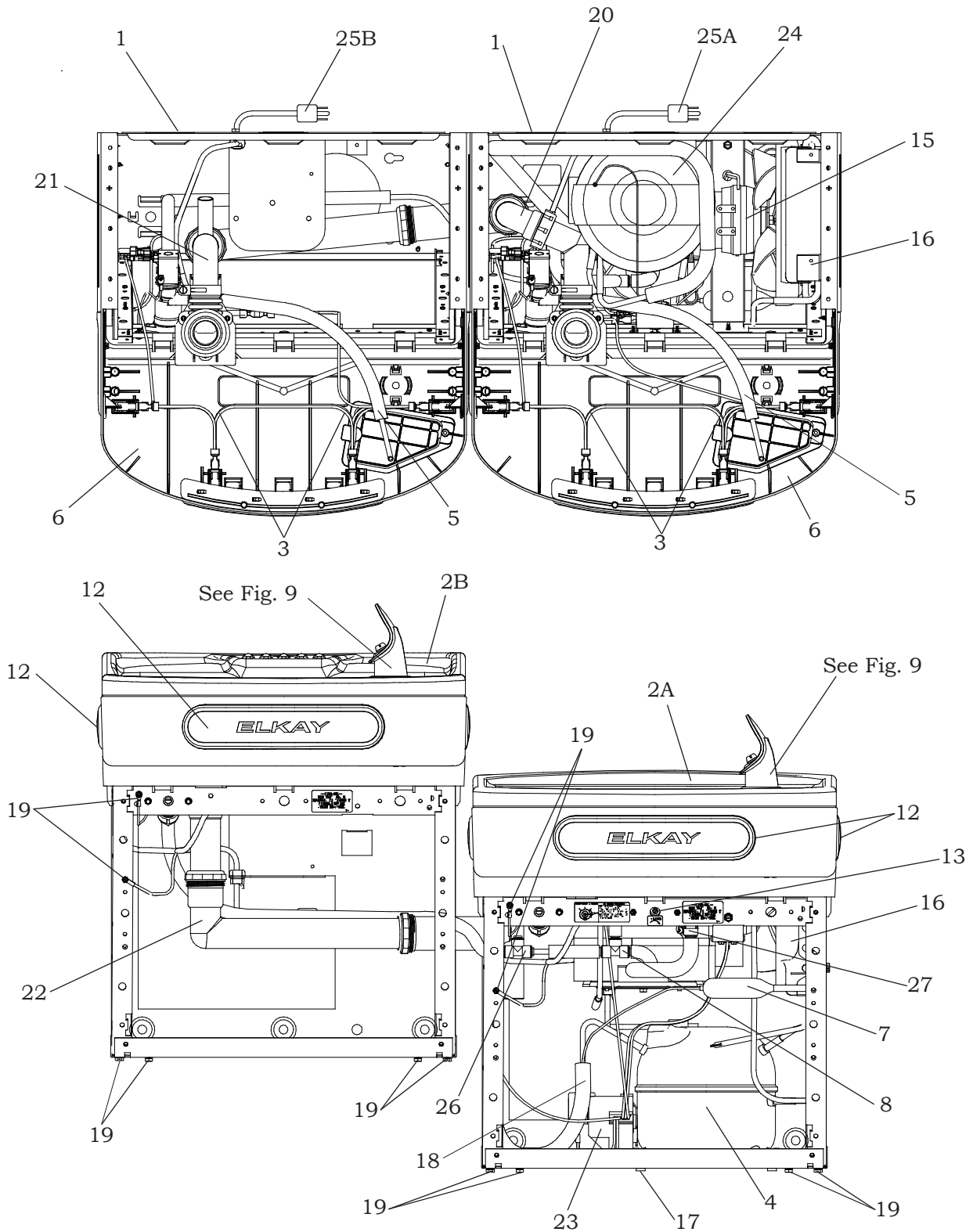

Fig. 1

EZ/LZ TWO LEVEL STANDARD INSTALLATION

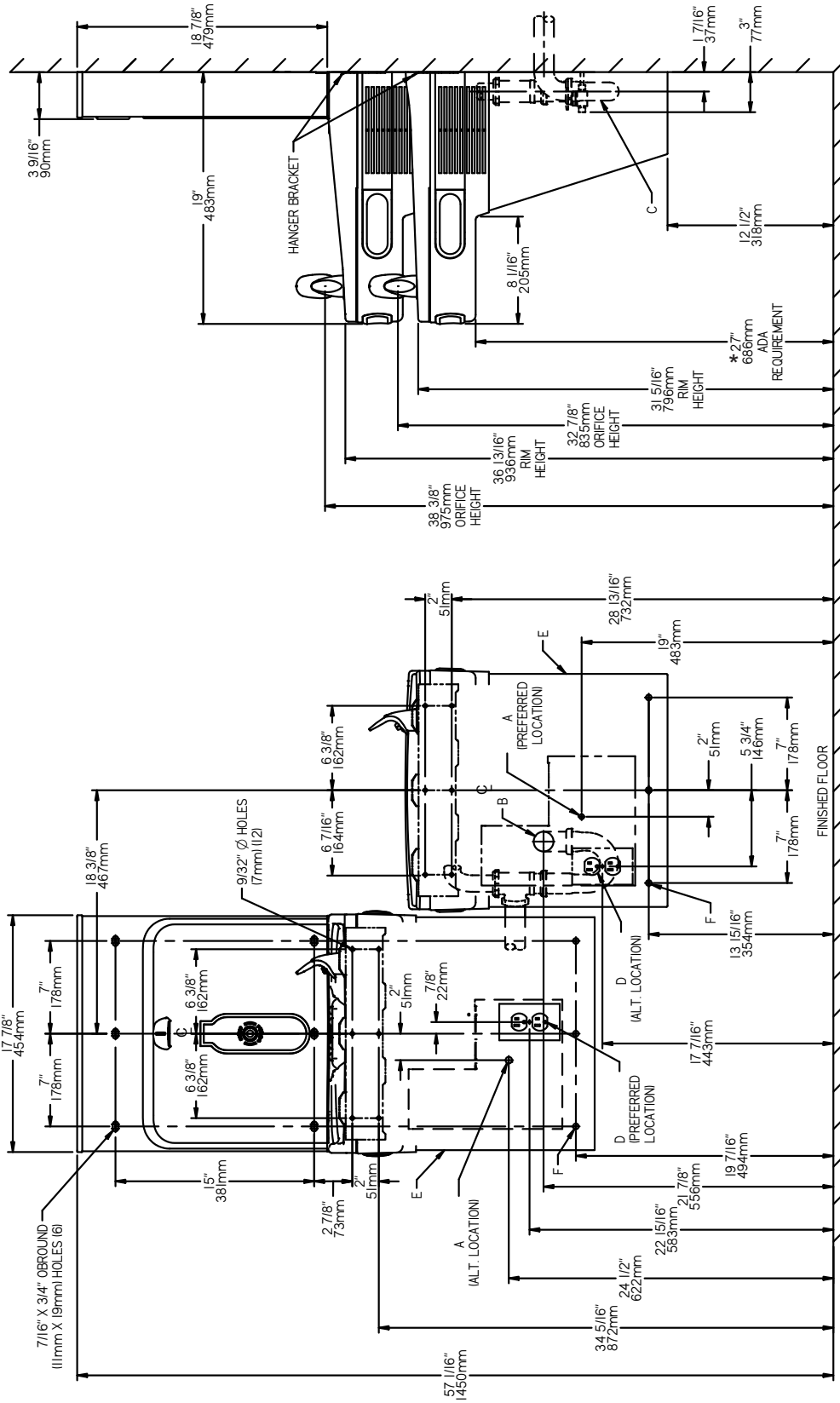

Fig. 2

*ADA REQUIREMENT
*REQUISITO DE A.D.A.
*EXIGENCE ADA

*** REDUCE HEIGHT BY 3 INCHES FOR INSTALLATION OF CHILDRENS ADA COOLER**

LEGEND/LEYENDA/LÉGENDE
A = RECOMMENDED WATER SUPPLY LOCATION 3/8 O.D. UNPLATED COPPER TUBE CONNECT STUB WITH SHUT OFF (BY OTHERS) 3 IN. (76mm) MAXIMUM OUT FROM WALL
 La UBICACION 3/8 O RECOMENDADA de ABASTECIMIENTO DE AGUA. D. El TUBO del COBRE de UNPLATED CONECTA TALONARIO CON APAGO (POR OTROS) 3 en. (76 Mm) el MAXIMO FUERA DE PARED
 L'O.D de 3/8 (EMPLACEMENT DE PROVISION D'EAU RECOMMANDÉ. LE TUBE DE CUIVRE DE UNPLATED CONNECTE STUB AVEC ÉTEINT (PAR LES AUTRES) 3 dans. (76 mm) le MAXIMUM HORS DU MUR
B = RECOMMENDED LOCATION FOR WASTE OUTLET 1-1/2" O.D. DRAIN STUB 2 IN. OUT FROM WALL
 UBICACION RECOMENDADA PARA EL DRENAJE DE SALIDA DE AGUA. DE 1-1/2" DE DIÁMETRO. El TALONARIO 2 FUERA DE PARED
 EMPLACEMENT RECOMMANDÉ POUR LE DRAIN DE D.E. 1-1/2" DE SORTIE D'EAU. STUB 2 HORS DU MUR
C = 1-1/2" TRAP NOT FURNISHED
 PURGADOR DE 1-1/2" NO PROPORCIONADO
 SIPHON 1-1/2" NON FOURNI
D = ELECTRICAL SUPPLY (3) WIRE RECESSED BOX**
 CAJA RECESIVA DE ALAMBRES (3) DE SUMINISTRO ELÉCTRICO
E = INSURE PROPER VENTILATION BY MAINTAINING 6" (152 mm) (MIN.) CLEARANCE FROM CABINET LOUVERS TO WALL.
 ASSEGURE UNA VENTILACION ADECUADA MANTENIENDO UN ESPACIO E 6" (152 mm) (MIN.) DE HOLGURA ENTRE LA REJILLA DE VENTILACION DEL MUEBLE Y LA PARED.
 ASSUREZ-VOUS UNE BONNE VENTILATION EN GARDANT 6" (152 mm) (MIN.) ENTRE LES EVENTS DE L'ENCEINTE ET LE MUR.
F = 7/16 BOLT HOLES FOR FASTENING UNIT TO WALL
 AGUJEROS DE LAS TUBERIAS DE 7/16 PARA SUJETAR LA UNIDAD A LA PARED
 TROUS D'ÉCROUS 7/16 POUR FIXER L'APPAREIL AU MUR
****NEW INSTALLATIONS MUST USE GROUND FAULT CIRCUIT INTERRUPTER (GFCI)**
 **Las nuevas instalaciones deben utilizar el interruptor de circuito de tierra de la avería (GFCI)
 **Les nouvelles installations doivent employer l'interrupteur de circuit moulu de défaut (GFCI)

HANGER BRACKETS & TRAP INSTALLATION

- 1) Remove hanger brackets fastened to back of cooler by removing one (1) screw.
- 2) Mount the hanger brackets as shown in Figure 2 or 3.

NOTE: Hanger Bracket MUST be supported securely. Add fixture support carrier if wall will not provide adequate support. Anchor hanger securely to wall using all six (6) 1/4 in. dia. mounting holes.

IMPORTANT:

5-7/8 in. (150mm) dimension from wall to centerline of trap must be maintained for proper fit.

INSTALLATION OF COOLER

- 3) Hang the cooler on the hanger bracket. Be certain the hanger bracket is engaged properly in the slots on the cooler back as shown in Figure 2 or 3.
- 4) Remove the four (4) screws holding the lower front panel at the bottom of cooler. Remove the front panel by pulling straight down and set aside.
- 5) Connect water inlet line--See Note 4 above.
- 6) Install trap. Remove the slip nut and gasket from the trap and install them on the cooler waste line making sure that the end of the waste line fits into the trap. Assemble the slip nut and gasket to the trap and tighten securely.

IMPORTANT: If it is necessary to cut the drain, loosen the screw at the black rubber boot and remove tube, check for leaks after re-assembly.

- 7) Plug in electrical power. Unit must have electrical power to have water flow.

START UP

Also See General Instructions

- 8) Stream height is factory set at 35 PSI. If supply pressure varies greatly from this, adjust screw located on the left side below push bar ass'y. on crossbar. CW adjustment will raise stream and CCW adjustment will lower stream. For best adjustment, stream should hit basin approximately 6-1/2" (165mm) from bubbler on the downward slope of the basin.
- NOTE:** If continuous flow occurs at the end of the compressor cycle, turn cold control counter-clockwise 1/4 turn.
- 9) Replace the front panel ensuring that the metal wrapper is secured inside of the upper shroud. Replace all four screws previously removed.

CLEANING

Warm, soapy water or mild household cleaning products can be used to clean the exterior panels of the EZ coolers. Extra caution should be used to clean the mirror finished stainless steel panels. They can be easily scratched and should only be cleaned with mild soap and water or Windex glass cleaner and a clean, soft cloth. Use of harsh chemicals or petroleum based or abrasive cleaners **will void the warranty.**

INSTALACIÓN DE LOS SOPORTES FIJADORES Y EL PURGADOR

- 1) Retire el soporte fijador que se encuentra conectado a la parte posterior del enfriador sacando un (1) tornillo.
- 2) Monte el soporte fijador de la manera descrita en Fig. 2 y 3.

NOTA: Es necesario que el soporte fijador sea apoyado seguramente. Agregue un portador al soporte fijador si La pared no aporta soporte adecuado. Amarre el soporte colgante seguramente a la pared. Usando todos los seis (6) agujeros de montaje de ¼ pulg. (63.5 mm) de diám.

IMPORTANTE:

Es necesario mantener una distancia de 5-7/8 pulg. (150mm) de la pared a la línea central del purgador para poder obtener un ajuste correcto.

INSTALACIÓN DEL ENFRIADOR

- 3) Cuelgue el enfriador en el soporte colgante. Asegúrese que el soporte colgante está enganchado adecuadamente en las ranuras en la parte posterior del enfriador según descrito en Figura 2 y 3.
- 4) Retire los cuatro (4) tornillos que sujetan el panel frontal inferior en el pie del enfriador. Retire el panel frontal al jalarlo hacia abajo y póngalo al lado.
- 5) Conecte la tubería de entrada de agua – Consulte la Nota 4 de la Instrucciones Generales.
- 6) Instale el purgador. Retire la tuerca deslizante y el obturador del purgador e instálelos en la tubería de descarga del enfriador, asegurándose de que el extremo de la tubería de descarga encaje en el purgador. Ensamble la tuerca deslizante y el obturador en el purgador y apriete firmemente.

IMPORTANTE: Si llega a ser necesario cortar la tubería de descarga, afloje el tornillo en el fuelle negro de goma y retire la tubería, después del reensamblaje, compruebe que no haya pérdidas.

- 7) Enchufe la alimentación eléctrica.

INICIO

También consulte las Instrucciones Generales

- 8) La altura del chorro viene predefinida de la fábrica en 35 psi. Si la presión de la fuente varía grandemente de esto, ajuste el tornillo situado en el lado izquierdo debajo de la barra del empuje ass'y. en la barra transversal. Un ajuste en el sentido de las manecillas del reloj alzará al chorro y un ajuste en el sentido contrario a las manecillas del reloj bajará el chorro. Para lograr el mejor ajuste, el chorro debe caer al estanque aproximadamente un 6-1/2 pulg. (165 mm) del grifo en la inclinación hacia abajo del estanque.
- NOTA:** Si ocurre un flujo continuo al fin del ciclo del compresor, gire el control del agua fría una cuarta vuelta en el sentido contrario a las manecillas del reloj.
- 9) Reemplace el panel frontal asegurando que la envoltura metálica está bien sujeta adentro de la cubierta superior. Reemplace todos los cuatro tornillos previamente retirados.

LIMPIEZA

Se puede usar agua tibia enjabonada o un producto no abrasivo de limpieza para limpiar los paneles exteriores de los enfriadores EZ. Debe usar mucho cuidado al limpiar los paneles de acero inoxidable de acabado espejo. Es muy fácil rayarlos y únicamente debe limpiarse con jabón no abrasivo y agua o con el limpiador de vidrios Windex y un paño limpio y suave. El uso de productos químicos o limpiadores abrasivos o aquellos basados en petróleo **anulará la garantía.**

INSTALLATION DES SUPPORTS DE SUSPENSION ET DU SIPHON

- 1) Retirez le support de suspension fixé au dos du refroidisseur en retirant une (1) vis.
- 2) Montez le support de suspension comme indiqué dans la figure 2 et 3.

REMARQUE: Le support de suspension doit être accroché sûrement. Renforcez le soutien du mur par l'ajout d'un élément porteur fixe si le mur ne peut pas, à lui tout seul, offrir un soutien suffisant. Fixez le support au mur en utilisant des trous de fixation de 6 pouces ¼ de diamètre.

IMPORTANT:

Une distance de 5 à 7 pouces (150 mm) entre le mur et l'axe du siphon doit être respectée pour assurer une pose correcte.

INSTALLATION DU REFRIGÉRISEUR

- 3) Pendez le refroidisseur au support de suspension. Assurez-vous que le support est correctement inséré dans les emplacements au dos du refroidisseur, comme indiqué dans la figure 2 et 3.
- 4) Retirez les four (4) vis maintenant en place le panneau frontal au bas du refroidisseur. Retirez le capot inférieur en tirant vers le bas et mettez-le de côté.
- 5) Reliez l'alimentation en eau — Référez-vous à la remarque 4 des Instructions Générales.
- 6) Mettez en place le siphon. Retirez l'écrou coulissant et le joint statique du siphon et installez-les sur la conduite résiduaire du refroidisseur en vérifiant bien que l'extrémité de la conduite résiduaire entre dans le siphon. Installez l'écrou coulissant et le joint statique au siphon et serrez fortement.

IMPORTANT: Au cas où il serait nécessaire de couper le drain, désérrez la vis située sur la gaine noire en caoutchouc et retirez le tube, puis vérifiez qu'il n'y a pas de fuites avant de remonter.

- 7) Branchez l'alimentation électrique.

DEMARRAGE

Voir également le chapitre Instructions Générales

- 8) La pression de la vapeur a été réglée en usine à 35 psi. Si la pression d'approvisionnement change considérablement de ceci, ajustez la vis plac du côté gauche au-dessous de la barre de poussée ass'y. sur la barre transversale Le réglage dans le sens des aiguilles d'une montre augmente le jet, et dans le sens inverse le diminue. Pour un meilleur réglage, le jet doit frapper le bassin à une distance d'environ 6 pouces et demi (165 mm) du barboteur sur la pente descendante du bassin.
- REMARQUE:** Si un flot continu se déclenche à la fin du cycle de compression, tournez le Contrôle de refroidissement d'un quart de tour dans le sens inverse des aiguilles d'une montre.
- 9) Remettez le panneau frontal en place en vérifiant que le couvre-joint métallique est bien installé à l'intérieur de l'enveloppe de protection supérieure. Revissez les four vis ôtées précédemment.

ENTRETIEN

Utiliser de l'eau tiède savonneuse ou des produits de nettoyage domestiques doux pour nettoyer les panneaux extérieurs des refroidisseurs EZ. Une prudence supplémentaire est requise lors du nettoyage du miroir ou des panneaux inox. Ces éléments peuvent se rayer facilement et doivent être uniquement nettoyés à l'aide de savon doux et d'eau ou de liquide nettoyant pour vitres Windex et d'un chiffon doux et propre. L'utilisation de produits chimiques corrosifs et de nettoyants abrasifs ou dérivés du pétrole **annulera la garantie constructeur.**

Service Instructions

Lower and Upper Shroud

To access the refrigeration system and plumbing connections, remove four screws from bottom of cooler to remove the lower shroud. To remove the upper shroud for access to the pushbars, regulator, solenoid valve or other components located in the top of the unit, remove lower shroud, disconnect drain, remove four screws from tabs along lower edge of upper shroud, unplug two wires and water tube.

Bubbler

To remove the bubbler, first disconnect the power supply. The underside of the bubbler can be reached through the access panel on the underside of the upper shroud. Remove the access panel by removing the retaining screw. To remove the bubbler, loosen locknut from the underside of the bubbler and remove the tubing from the quick connect fitting per the Operation Of Quick Connect Fittings section in the General Instructions. After servicing, replace the access panel and retaining screw.

Switches Behind the Push Bar

The regulator in an EZ cooler is always held fully open by the use of a single regulator nut (See Fig. 10). Water is not dispensed until the pushbar is depressed to activate a switch which then opens a solenoid valve. When installing the regulator nut, the regulator spring must be depressed while turning the nut.

Single bar units will have the same wiring as side push bar units but will not have the extra leads attached to sidebars.

To remove sidebars, from the inside compress the flared tabs and pull out carefully. To reinstall side pushbars, the front of the pushbar is inserted first. While keeping the switch depressed, snap the rear of the pushbar into position.

Atienda a Instrucciones

Las cubiertas inferiores y superiores

Para obtener acceso al sistema de refrigeración y las conexiones de plomería, retire cuatro tornillos de la parte inferior del enfriador para así poder retirar la cubierta inferior. Para retirar la cubierta superior para obtener acceso a las barras topes de empuje, regulador, la válvula del solenoide u otros componentes ubicados en la parte superior de la unidad, retire la cubierta inferior, desconecte el tubo de desagüe, retire cuatro tornillos de las lengüetas a lo largo del borde inferior de la cubierta superior, desenchufe dos cables y la tubería de agua.

Burbujeador

Para quitar el burbujeador, primero hay que desconectar la alimentación.

Se puede obtener acceso a la parte inferior del burbujeador a través del panel de acceso en la parte inferior de la cubierta superior. Quite el panel de acceso sacando el tornillo de retención. Para retirar el burbujeador, suelte la contratuerca de la parte inferior del burbujeador y saque la tubería del accesorio de conexión rápida según descrito en la sección Funcionamiento de los Accesorios de Conexión Rápida en las Instrucciones Generales. Después de realizar el servicio, reemplace el panel de acceso y el tornillo de retención.

Interruptores detrás de la barra tope de empuje

El enfriador EZ es parecido a un sensor fotoeléctrico en que el regulador siempre está completamente abierto pero no surte el agua hasta que la barra tope se empuje (Figura 10). Se escuchará un sonido de chasquidos al activar el interruptor y la válvula del solenoide. Una sola tuerca del regulador mantiene abierto el regulador en todo momento. Al instalar la tuerca, es necesario presionar el resorte del regulador mientras gira la tuerca.

Unidades con una sola barra tendrán el mismo cableado que las unidades con barras topes laterales pero no tendrán los cables extras conectados a las barras laterales.

Para retirar las barras laterales, desde el interior, hay que contraer las lengüetas acampanadas y retire cuidadosamente. Para reinstalar las barras laterales, se debe introducir la parte frontal de las barras primero. Con el interruptor presionado, encaje con un chasquido la parte posterior de la barra tope en la posición correcta.

Entretenir des Instructions

Enveloppes de Protection Supérieure et Inférieure

Pour accéder au système de réfrigération et aux raccords de plomberie, retirez les six vis situées au bas du refroidisseur pour retirer l'enveloppe inférieure.

Pour retirer l'enveloppe supérieure afin d'avoir accès aux boutons-poussoir, au régulateur, à l'électrovanne ou à tout autre composant situé au sommet de l'unité, retirez l'enveloppe inférieure, déconnectez le drain, retirez les quatre vis des pattes situées le long de l'arête inférieure de l'enveloppe supérieure, et débranchez les deux câbles ainsi que le raccordement en eau.

Barboteur

Pour déposer le barboteur, débranchez d'abord l'alimentation électrique.

Le dessous du barboteur est accessible par le biais du panneau d'accès sur la face inférieure du collecteur d'air. Déposez le panneau d'accès en retirant la vis de retenue. Pour déposer le barboteur, desserrez l'écrou de blocage du dessous du barboteur et retirez la tubulure à partir du raccord rapide conformément à la section Utilisation des raccords rapides dans les instructions générales. Une fois le travail terminé, remplacez le panneau d'accès et la vis de

Interrupteurs derrière le bouton-poussoir

Le refroidisseur EZ a un fonctionnement similaire à celui d'un capteur photo-électrique, dans le sens où le réglage est toujours complètement ouvert mais ne dispense de l'eau que lorsque l'on presse le bouton-poussoir (composant 10). Un cliquetis se produit quand l'interrupteur et l'électrovanne se mettent en marche. Un seul écrou de réglage maintient le réglage en position ouverte en permanence. Lors de l'installation de l'écrou, le ressort de détente doit être en position relâchée pendant le réglage de l'écrou.

Les unités à une barre possèdent le même câblage que les unités à boutons-poussoir latéraux mais ne possèdent pas les connexions supplémentaires attachées aux barres latérales.

Afin de retirer les barres latérales, pressez les pattes évasées de l'intérieur et tirez doucement. Pour réinstaller les barres latérales, la partie avant est d'abord insérée. En gardant l'interrupteur relâché, encastrez l'arrière du bouton-poussoir en position.

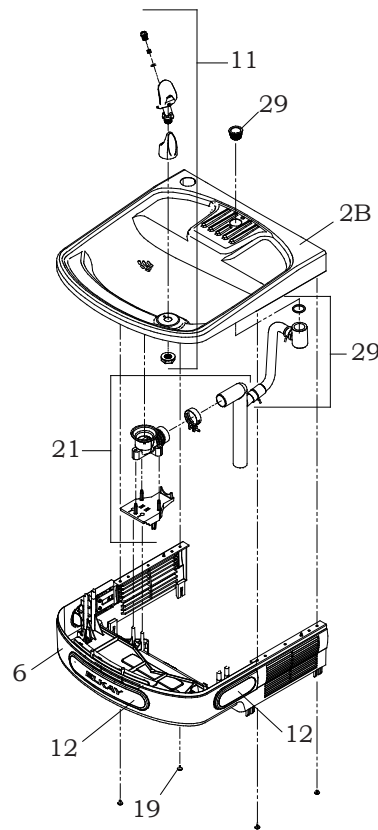

Fig. 3

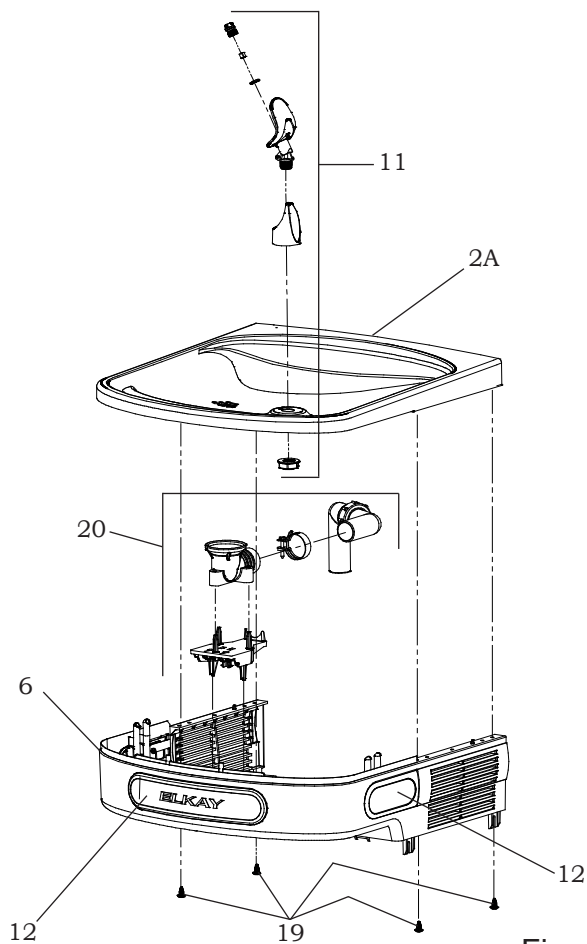

Fig. 4

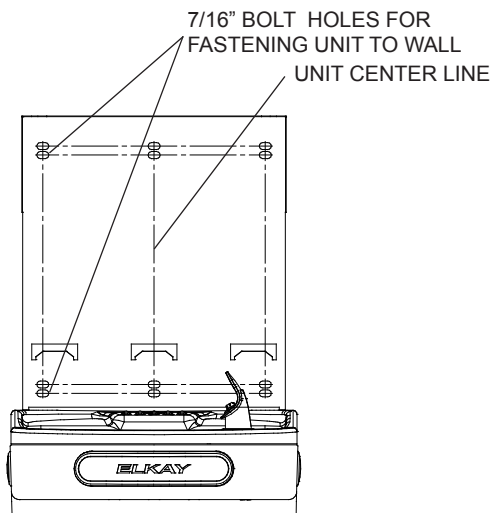

Fig. 5

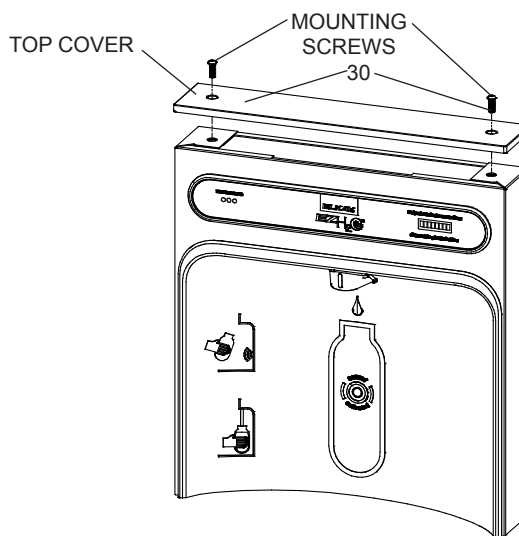

Fig. 6

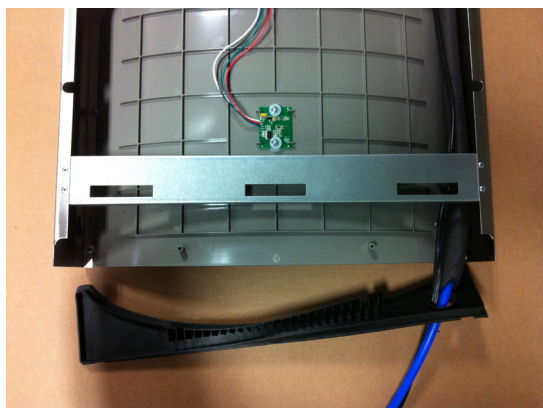

Fig. 7

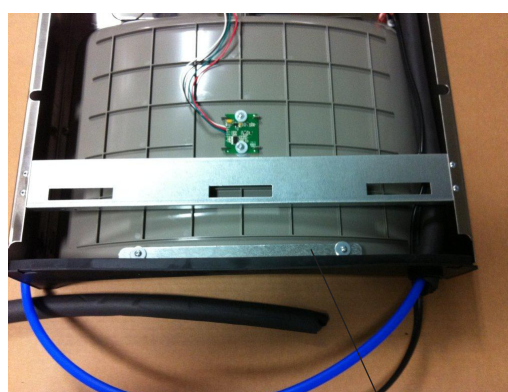

Fig. 8

BRACKET, WASHERS,
& SCREWS

Bottle Filler Installation Instructions

- 1) Remove two (2) mounting screws with 5/32" Allen wrench holding top cover to Bottle Filler (See Fig. 6). Remove top cover. Note do not discard mounting screws, they will be needed to reinstall top cover.
- 2) Remove wall mounting plate from Bottle Filler. Place wall plate against wall on top of basin. Center the wall plate side to side with the basin. Mark the six (6) mounting holes with a pencil (See Fig. 2).
- 3) Remove wall mounting plate from wall. **NOTE:** Mounting plate **MUST** be supported securely. Add fixture support carrier if wall will not provide adequate support.
- 4) Install wall mounting plate to wall using six (6) 7/16" obround mounting holes (mounting bolts not included) (See Fig. 5). Use appropriate fasteners for your wall type.
- 5) Feed power cord & 3/8" water line through hole in tower/basin gasket (See Fig 7).
- 6) Install gasket on bottom of bottle filler tower with gasket support bracket, (2) washers, & (2) screws (See Fig 8).
- 7) Fish the purple wire (single units) or the purple and yellow wires (two-level units) up through basin hole & hole in gasket.
- 8) **For Single Model installations:** Attach the purple wire from cooler to the purple wire on the back of the unit, (Note yellow wire is not used).
- 8a) **For Two-Level model installations:** Attach the purple and yellow wires from coolers to the purple and yellow wires on the back of the unit, purple to purple, yellow to yellow.
- 9) Lay Bottle Filler on water cooler basin and cut insulation from tube even with bottom of gasket, remove this insulation from the 3/8" tube, but do not discard. Fish the power cord and waterline through the hole on top of water cooler. **NOTE:** To prevent scratching the basin place a towel or soft cloth over the entire basin when working above it.
- 10) With the power cord, wire(s), and waterline through hole on top of water cooler place Bottle Filler on the three (3) angled tabs protruding from the wall mounting plate, installed on wall. Make sure round boss in gasket fits in hole of basin. (See Fig. 15).
- 11) Once Bottle Filler is installed on wall plate tabs, water line, wire(s) and power cord are installed properly, push top of Bottle Filler toward wall and line up top cover two (2) holes.
- 12) Reinstall Top Cover on Bottle Filler (See Fig. 6) with two mounting screws from step 1 above. Caution, do not over tighten screws.
- 13) Install remaining tube insulation to the water line from bottle filler, connect Bottle Filler waterline inside of the water cooler by connecting the 3/8" water line to the tee.
- 14) Install filter cartridge, remove filter from carton, remove protective cap, attach filter to filter head by firmly inserting into head and rotating filter clockwise. **NOTE:** If existing plumbing rough in locations (Drain, Water In, and Electric Supply) do not allow the filter to be mounted inside the cooler cabinet the filter can be installed horizontally below the unit. A retrofit kit is available to mount the filter beneath the cooler.
- 15) Turn water supply on and inspect for leaks. Fix all leaks before continuing.
- 16) Once unit has been inspected for leaks and any leaks found corrected, plug Bottle Filler and unit into wall. Be sure to reinstall fuse to the circuit or switch the circuit breaker back to the "ON" position.
- 17) Once power is applied to Bottle Filler, the GREEN LED light should illuminate showing good filter status along with the LCD Bottle Counter.
- 18) Verify proper dispensing by placing cup, hand, or any opaque object in front of sensor area and verify water dispenses. Note: the first initial dispenses might have air in line which may cause a sputter. This will be eliminated once all air is purged from the line.
- 19) Once unit tests out, install Lower Panel back on water cooler(s). Units are now ready for use.

BF11 PROGRAM

SETTING THE CONTROL BOARD

VERIFY CONTROL BOARD SOFTWARE

- 1) To verify the software program of the control board the unit will need to be shut down and restarted. The chiller (if present) does not need to be shut down and restarted.
- 2) The units lower panel must be open to access the power cord and wall outlet.
- 3) Shut down the unit by unplugging the power cord from the wall outlet.
- 4) Restart the unit by plugging the power cord back into the wall outlet.
- 5) Upon start up, the bottle count display will show the software designation of BF11.

ACCESSING THE PROGRAMMING BUTTON

- 1) To access the program button remove the top cover of the bottle-filler. Remove the two (2) screws holding top cover to bottle-filler with a 5/32" allen wrench. Remove top cover. Do not discard mounting screws, they will be needed to reinstall the top cover after programming operations are completed. The programming button is located at the top right side of the unit on the control board.

RESET THE FILTER MONITOR

- 1) Instructions apply to filtered units only.
- 2) Depress the program button for approximately 2 seconds until the display changes then release. The display will change and scroll through two messages:
"RST FLTR" – Reset Filter Monitor
"SETTINGS" – System Settings Sub Menu
If the program button is not pushed again the display will scroll through the two messages above for three cycles and then default back to bottle count and be back in run mode.
- 3) When the display changes to "RST FLTR", depress the button again. The display will change to show "FLTR =". Depress the button again and the display will show "FLTR =0"
- 4) The Green LED should be illuminated indicating that the visual filter monitor has been reset.

SETTING RANGE OF THE IR SENSOR

- 1) Depress the program button for approximately 2 seconds until the display changes then release. The display will change and scroll through two messages:
"RST FLTR" – Reset Filter Status LED
"SETTINGS" – System Settings Sub Menu
If the program button is not pushed again the display will scroll through the two messages above for three cycles and then default back to bottle count and be back in run mode.
- 2) When the display changes to "SETTINGS", depress the button again. The display will change to show
"RNG SET" - Range set for IR sensor.
"UNIT TYP" - Type of unit (REFRIG or NON-RFRG)
"FLT SIZE" - Select filter capacity
"RST BCNT" - Reset bottle count
- 3) When display shows "RNG SET" push program button once the display will show current value (can be 1 – 10) e.g. "RNG = 3".
- 4) Once display shows current value push the program button to scroll through value of 1 – 10. Select the desired range setting.
- 5) Once range is selected allow approximately 4 seconds to pass and then the display will go back to bottle counter and be in run mode.
- 6) Test bottle filler by placing bottle or hand in front of sensor to make sure water is dispensed.

SETTING UNIT TYPE

- 1) Depress the program button for approximately 2 seconds until the display changes then release. The display will change and scroll through two messages:
"RST FLTR" – Reset Filter Status LED
"SETTINGS" – System Settings Sub Menu
If the program button is not pushed again the display will scroll through the two messages above for three cycles and then default back to bottle count and be back in run mode.

Continued from below:

- 2) When the display changes to "SETTINGS", depress the button again. The display will change to show
"RNG SET" - Range set for IR sensor.
"UNIT TYP" - Type of unit (REFRIG or NON-RFRG)
"FLT SIZE" - Select filter capacity
"RST BCNT" - Reset bottle count
- 3) When display shows "UNIT TYPE" push program button once the display will show current value. Can be REFRIG or NON-RFRG
- 4) Push button once to change value. Once value is selected the display will show the new value. (Can be REFRIG or NON-RFRG)
"REFRIG" - stands for refrigerated product. In this setting the flow rate is estimated at 1.0 gallon per minute.
"NON-RFRG" - stands for nonrefrigerated product. In this setting the flow rate is estimated at 1.5 gallons per minute. Both "REFRIG" and "NON-RFRG" simulate 1 bottle equal to 20 oz.
- 5) Allow approximately 4 seconds to pass and the display will return to bottle counter and be in run mode.

RESETTING BOTTLE COUNT

- 1) Depress the program button for approximately 2 seconds until the display changes then release. The display will change and scroll through two messages:
"RST FLTR" – Reset Filter Status LED
"SETTINGS" – System Settings Sub Menu
If the program button is not pushed again the display will scroll through the two messages above for three cycles and then default back to bottle count and be back in run mode.
- 2) When the display changes to "SETTINGS", depress the button again. The display will change to show:
"RNG SET" - Range set for IR sensor.
"UNIT TYP" - Type of unit (REFRIG or NON-RFRG)
"FLT SIZE" - Select filter capacity
"RST BCNT" - Reset bottle count
If the button is not pushed again the display will scroll through the four messages above for three cycles and return to run mode.
- 3) When display shows "RST BCNT" push program button once the display will show current value e.g. "0033183".
- 4) Once display shows current value push the program button once more to reset back to 0. The display will show BTLCT = 0 for approximately 2 seconds and then return to run mode showing 00000000 bottles.
- 5) Testing the bottle counter:
REFRIG units: Place bottle or hand in front of sensor for 9.4 seconds to see bottle counter count 00000001,
(This is based on filling a 20 oz. bottle).
NON-RFRG units: Place bottle or hand in front of sensor for 6.25 seconds to see bottle counter count 00000001,
(This is based on filling a 20 oz bottle).

SETTING FILTER CAPACITY

- 1) Depress the program button for approximately 2 seconds until the display changes then release. The display will change and scroll through two messages:
"RST FLTR" – Reset Filter Status LED
"SETTINGS" – System Settings Sub Menu
If the program button is not pushed again the display will scroll through the two messages above for three cycles and then default back to bottle count and be back in run mode.
- 2) When the display changes to "SETTINGS", depress the button again. The display will change to show:
"RNG SET" - Range set for IR sensor.
"UNIT TYP" - Type of unit (REFRIG or NON-RFRG)
"FLT SIZE" - Select filter capacity
"RST BCNT" - Reset bottle count
If the button is not pushed again the display will scroll through the four messages above for three cycles and return to run mode.
- 3) When display shows "FLT SIZE" push program button once. The display will show current value. Can be 3000GAL or 6000GAL.
- 4) Push program button again to display the desired "FLT SIZE".
- 5) Allow approximately 4 seconds to pass and the display will return to bottle counter and be in run mode.

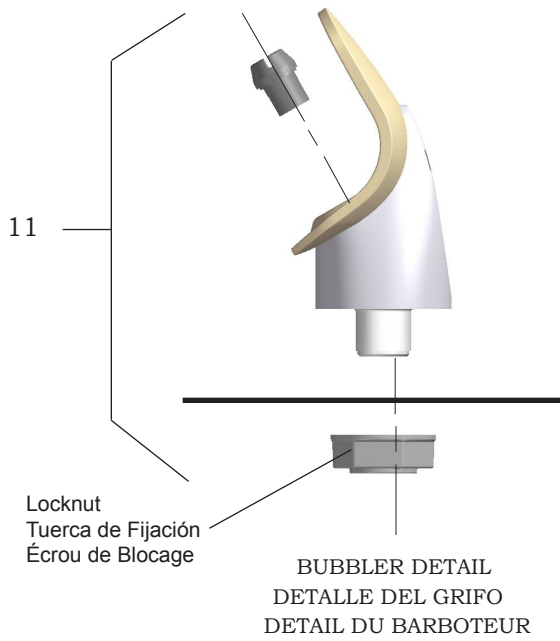

NOTE:

When installing replacement bubbler and pedestal, tighten nut only to hold parts snug in position. Do Not Overtighten.

NOTA:

Al instalar el grifo y pedestal de reemplazo, apriete la tuerca unicamente para mantener las piezas en una posicion ajustada. No debe apretarse demasiado.

REMARQUE:

Lors de L'installation du barboteur de remplacement ou du socle, serez la vis afin de maintenir les elements en place. Ne Pas Serrer Trop Fortement.

Basin
Estanque
Bassin

Fig. 9

Cleaning the strainer

To clean the strainer, unscrew the cap of the solenoid valve. Remove screen and rinse thoroughly with water. Insert screen back into solenoid valve and screw cap on. Make sure the o-ring is placed properly.

Limpieza del filtro

Para limpiar el filtro, desatornille la tapa de la válvula solenoide. Retire la malla y enjuague a fondo con agua. Inserte nuevamente la malla en la válvula solenoide y atornille la tapa. Asegurese de que el retén anular quede colocado correctamente.

Nettoyage du filtre

Pour nettoyer le filtre, dévisser le bouchon du robinet électromagnétique (ou électrorobinet). Retirez l'écran et rincez-le à fond sous l'eau. Remettez l'écran en place dans l'électrorobinet puis revissez le bouchon. Assurez-vous que le joint torique est correctement positionné.

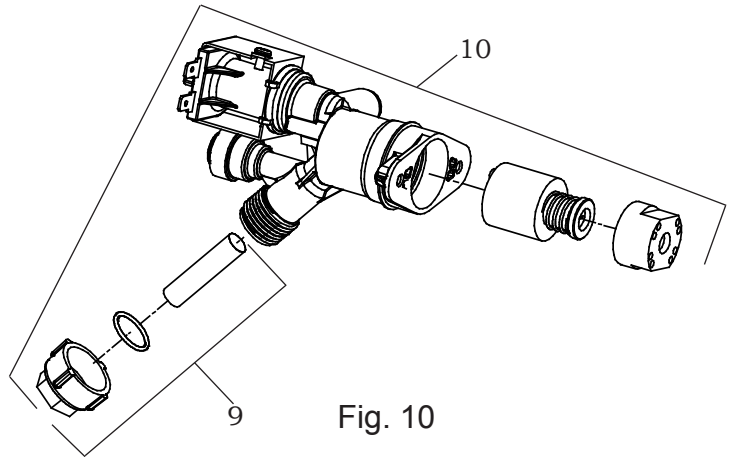

Fig. 10

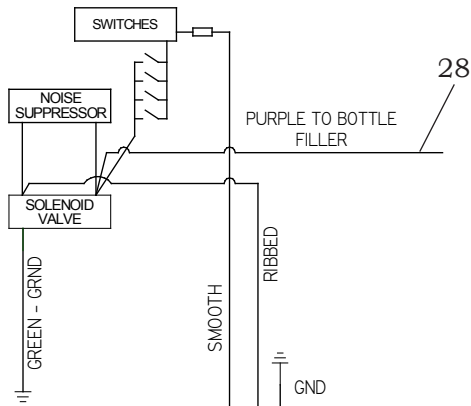

Fig. 11

115V Non-Refrigerated Wiring Diagram
Diagrama de cableado no refrigerados de 115 voltios
schéma de câblage non réfrigéré de 115 volts

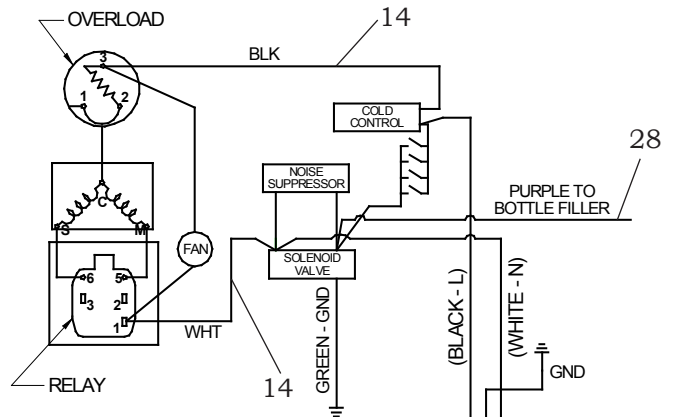
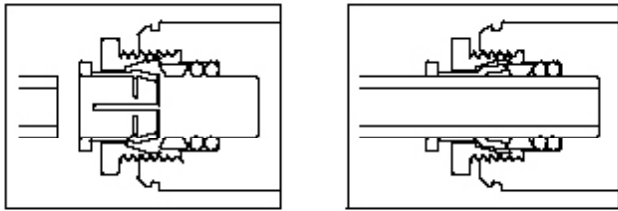

Fig. 12

115V Refrigerated Wiring Diagram
Diagrama de cableado refrigerados de 115 voltios
Schéma frigorifique de 115 volts



Note: Screw the locknut hand tight to seal

Fig. 13

OPERATION OF QUICK CONNECT FITTINGS

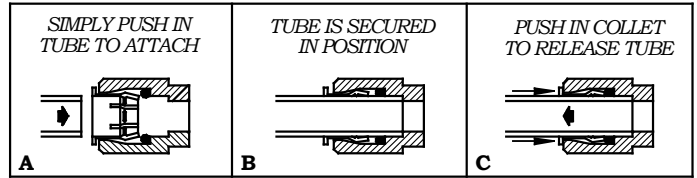

PUSHING TUBE IN BEFORE PULLING IT OUT HELPS TO RELEASE TUBE

Fig. 14

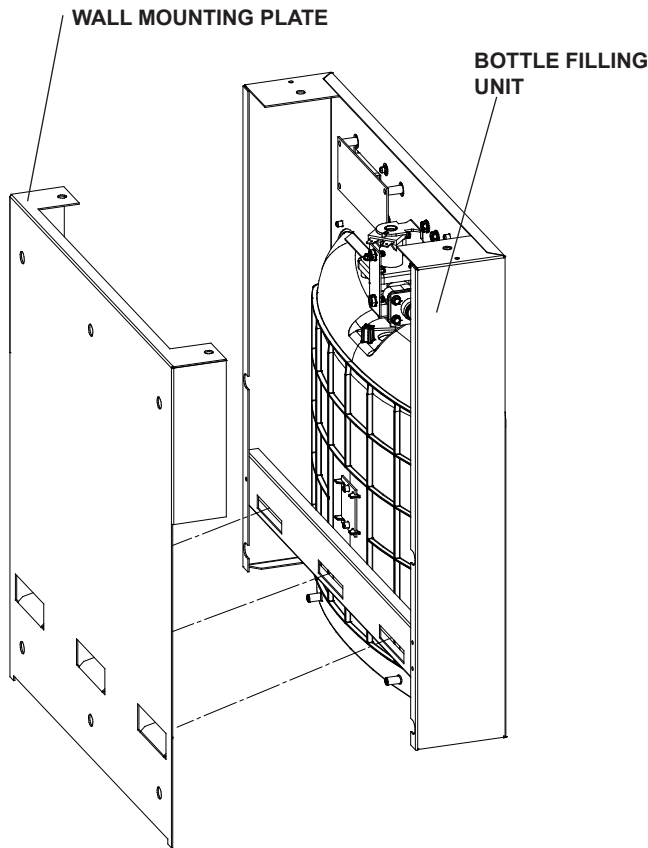

Fig. 15

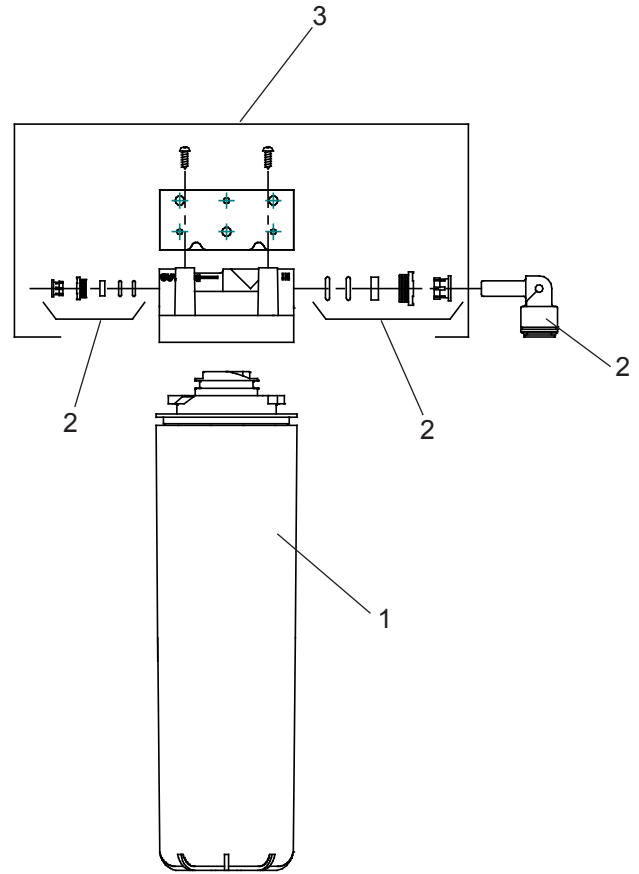

Fig.16

WATERSENTRY® Filter Detail
Detalle WATERSENTRY® Filtro
Description WATERSENTRY® Filtrage

WATERSENTRY® FILTER PARTS LIST (See Fig. 16)			LISTA DE PIEZAS DEL FILTRO (Vea la Fig. 16)	LISTE DES PIÈCES DU FILTRE (Voir Fig. 16)
ITEM NO.	PART NO.	DESCRIPTION	DESCRIPCIÓN	DESCRIPTION
1	51300C	Filter Assy-3000 Gal.	Ensamblado del Filtro-3000 Galón	Ens. filtre-3000 Gallon
2	98926C	Kit-Filter Head Fitting includes John Guest Fitting & 3/8" Elbow Fitting	Montaje Cabeza Kit Filtro-Incluye John Guest Montaje y 3/8" Codo	Raccord Tête de Filtre Kit-Inclut John Guest Montage et 3/8" Raccord en Coude
3	51469C	Assy -Filter & Bracket includes Filtr Head/Mtg Bkt/ John Guest Ftgs/Screws	Conjunto del Filtro y Soporte, Incluye Filtro Soporte/John Guest Guarniciones/ Tornillos de Montaje de Cabeza	Assemblée-Filtre et Support Inclut Filtre/Montage Support/John Guest/ Vis à Tête

Switch Activation

Note: Only side push activation is shown.
Front push works the same.

Detalle de la activación del interruptor

Nota: Lateral presión activación que se muestran. Frontal presión es la similar.

Description de l'activation de l'interrupteur

Remarque: Latéral poussoir activation que des indique. Face poussoir des semblable.

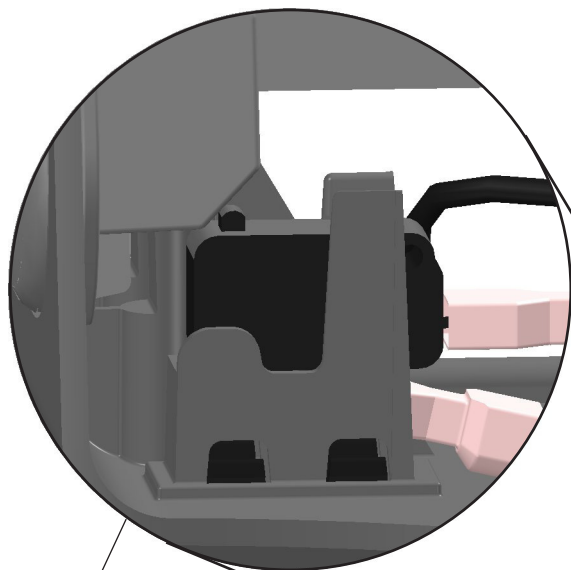

Open Switch Detail
Detalle Interruptor abierto
Description Interrupteur en position Marche



Closed Switch Detail
Detalle Interruptor cerrado
Description Interrupteur en position Arrêt

115V PARTS LIST/ 115V LISTA DE PIEZAS/ 115V LISTE DES PIÈCES				
ITEM NO.	PART NO.	DESCRIPTION	DESCRIPCIÓN	DESCRIPTION
1	28401C	Hanger Bracket	Soporte Colgante	Support de Suspension
2A	55001109	Basin - Stainless Steel	Estanque - Acero Inoxidable	Basin - Inox
2B	0000001337	Basin - Stainless Steel (BF)	Estanque - Acero Inoxidable (BF)	Basin - Inox (BF)
3	36216C	Wiring - Front/Side Push Bar	Barra de Empuje de Cableado-Frontal/Lateral	Barre Anti-Panique Câblage Avant/Côté
*4	0000000768	Compr - Service Pak 115V EM 65 HHC	Compresor Paquete de Servicio 115V EM 65 HHC	Kit d'Entretien du Compresseur 115V EM 65 HHC
5	56092C	Tube - Polyethylene 1/2" O.D. X 5' Lg.	Tubería de Polietileno (Corte a la Longitud)	Tubes - Polyéthylène (Couper à la Longueur)
6	56229C	Assy - Shroud - Upper (Front Side Push)	Cubierta - Superior (Frontal Lateral Presión)	Enveloppe de Protection - Supérieure (Face Latéral)
7	66703C	Drier	Secador	Poussoir) Déshydrateur
8	70682C	Tee - 1/4"	La te 1/4	Tee 1/4
9	98169C	Kit - Replacement Cap/Screen/O-Ring	Kit del Reemplazo Tapa/Malla/Reten Anular	Kit De Rechange De Bouchon/Ecran/Joint Torique
10	98466C	Kit - Solenoid Valve/Regulator Assy	Kit - Montaje del Regulador/Válvula Solenoide	Kit - Solénoïde de la Vanne/Régulateur
11	98501C	Kit - Flexi Stream saver Bubbler/ O-Ring/Nut	Kit - Flexi Stream saver Borboteador/ Oring/Teurca	Kit - Flexi Stream saver Barboteur/Oring/ Noix
12	98734C	Kit - Pushbar (Front/Side) EZS TL	Kit - Manillar (Frontal/Lateral) EZS TL	Kit - Barre de Poussée (Avant/Côté) EZS TL
13	98773C	Kit - Cold Control/Screws	Kit - Control del Enfriamiento/Tornillo	Kit - Contrôle de Refroidissement/Vis
14	98774C	Kit - Internal Wiring/Pwr Cord/Black and White Jumper Wires	Kit - Cableado Interno/Cable/Negro Y Blanco Puente	Kit - Câblage Interne/Câble d'Alimentation/Noir et Fils de Raccordement Blanc
15	98775C	Kit - Fan Motor Assy/Blade/Motor/Shroud/Screws/ Nut	Kit - Ventilador Motor Montaje/Hoja/Motor/ Cubierta/Tornillos/Tuerca	Kit - Ventilateur Moteur Assemblée/Lame/Moteur/ Cache/Vis/Écrou
16	98776C	Kit - Condenser/Drier	Kit - Condensador/Secador	Kit - Condenseur/Séchoir
17	98777C	Kit- Compr Mtg Hdwe/Grommets/ Clips/Studs	Kit - Matériel de Montaje Compresor/Ojal/ Pinza/Taquete	Kit - Montage du Compresseur Matériel/Joint d'étanchéité/Clip/Goujon
18	98778C	Kit - Heats/Drier	Kit - Intercambiador Térmico/Secador	Kit - Echangeur Thermique/Déshydrateur
19	98898C	Kit - Hardware (EZ)	Kit - Juego de Accesorios (EZ)	Kit - De Visserie (EZ)
20	98900C	Kit - Drain Replace EZTL8	Kit - Tubo de Desagüe - EZ8TL	Kit - Tube de Drainage EZ8TL
21	1000001877	Kit - Drain Replace EZTLD	Kit - Tubo de Desagüe - EZDTL	Kit - Tube de Drainage EZDTL
22	45874C	Kit - Wasteline Assy. TL	Kit - Malgaste la Asamblea de la Línea TL	Kit - Gaspiller d'Assemblée de Ligne TL
23	98750C	Kit - Compr Elect Capacitor/Relay/ Overload/Cover	Kit - Condensador del Compresor/Relé/ Sobrecarga/Cubierta	Kit - Condensateur de Compresseur/Relais/Surcharge/ Relais Coiffe
24	0000000745	Kit - Evaporator Assembly	Montaje del Kit-Evaporador	Assemblée de L'évaporateur en Kit
25A	36283C	Power Cord	Cable Eléctrico	Cordon d'alimentation
25B	35980C	Power Cord L/R	Cable Eléctrico L/R	Cordon d'Alimentation L/Réfrigérant
26	0000001144	Tee - 1/4 x 1/4 x 3/8	Tee - 1/4 x 1/4 x 3/8	Tee -1/4 x 1/4 x 3/8
27	1000001602	Kit-75583C Elbow 5/16" - 1/4"	Kit - 75583C Codo 5/16" - 1/4"	Coude Kit - 75583C 5/16" - 1/4"
28	36299C	Jumper Wire (Purple)	Cable - Puente (Púrpura)	Cable - Cavalier (Pourpre)
29	1000001812	Kit - Bottle Filler Drain (EZ)	Kit - de Drenaje de Llenada de la Botella (EZ)	Kit de Remplissage de Bouteille de Vidange
NS	0000000757	Wrapper - EZTL8 With Nmpit (L)	Envoltura - EZTL8 Con Placa (L)	Wrapper - EZTL8 Avec Plaque Signalétique (L)
NS	0000000756	Wrapper - EZTL8 With Nmpit (SS)	Envoltura - EZTL8 Con Placa (SS)	Wrapper - EZTL8 Avec Plaque Signalétique (SS)
NS	0000000761	Wrapper - EZTLD With Nmpit (L)	Envoltura - EZTLD Con Placa (L)	Wrapper - EZTLD Avec Plaque Signalétique (L)
NS	0000000760	Wrapper - EZTLD With Nmpit (SS)	Envoltura - EZTLD Con Placa (SS)	Wrapper - EZTLD Avec Plaque Signalétique (SS)
NS	28020C	Wrapper Filler - RH (L)	Llenado de Contenedor de Mano Derecha (L)	Remplissage de Wrapper de Main Droite (L)
NS	28021C	Wrapper Filler - RH (SS)	Llenado de Contenedor de Mano Derecha (SS)	Remplissage de Wrapper de Main Droite (SS)
NS	28024C	Wrapper Filler - LH (L)	Llenado de Contenedor de Mano Izquierda (L)	Remplissage de Wrapper de Main Gauche (L)
NS	28025C	Wrapper Filler - LH (SS)	Llenado de Contenedor de Mano Izquierda (SS)	Remplissage de Wrapper de Main Gauche (SS)
NS	28415C	Brkt-Trim Strip (L)	Soporte - Trim Tira (L)	Bande de Support-Trim (L)
NS	28414C	Brkt-Trim Strip (SS)	Soporte - Trim Tira (SS)	Bande de Support - Trim (SS)
-	See Filter Table	Water Filter Kit (When Provided)	Kit de Filtro de Agua (Cuando Provisto)	Kit de Filtrage d'Eau (Si Fourni)

*INCLUDES RELAY & OVERLOAD. IF UNDER WARRANTY, REPLACE WITH SAME COMPRESSOR USED IN ORIGINAL ASSEMBLY.
NOTE: All correspondence pertaining to any of the above water coolers or orders for repair parts MUST include Model No. and Serial No. of cooler, name and part number of replacement part.

*INCLUYE RELÉ Y SOBRECARGA. SI ESTÁ BAJO GARANTÍA, REEMPLACE CON EL MISMO COMPRESOR USADO EN EL ENSAMBLADO INICIAL.
NOTA: Toda la correspondencia relacionada con el enfriador de agua anterior o con una orden de reparación piezas DEBERÁ incluir el número de modelo y número de serie del enfriador, el nombre y número de pieza de la pieza de repuesto.

*COMPREND RELAIS ET SURCHARGE. SI SOUS GARANTIE, REMPLACEZ AVEC LE MÊME SURPRESSEUR QUE CELUI UTILISÉ ORIGINALEMENT.
NOTE: Toute correspondance au sujet des refroidisseurs d'eau courante ou toute commande de pièce de rechange DOIT inclure le numéro de modèle et le numéro de série du refroidisseur ainsi que le nom et le numéro de pièce à remplacer.

BOTTLEFILLER REPLACEMENT PART KITS

ITEM NO.	PART NO.	DESCRIPTION	DESCRIPCIÓN	DESCRIPTION
NS	98543C	Kit - Electrical Package	Paquete Kit - Eléctrico	Forfait Kit - Electricqueso
NS	98544C	Kit - IR Sensor	Sensor Kit - IR	Kit - Récepteur IR
NS	98545C	Kit - Solenoid Valve Replacement	Reemplazo de la Válvula de Solenoide Kit	Remplacement de la Valve Solénoïde - Kit
NS	98546C	Kit - Aerator Replacement	Reemplazo Kit - Aireador	Remplacement du Kit - Aérateur
26	98547C	Kit - Top Cover Replacement	Kit - Tapa Cubierta Reemplazo	Remplacement du Kit - Top Coverable
NS	98549C	Kit - Hardware & Waterway Parts	Piezas del Kit - De Hardware y Por Vía Navegable	Pièces Kit - Matériel et Voie Navigable
NS	98551C	Kit - Filter Mounting Cover	Cubierta del Filtro de Kit - De Montaje	Couvercle de Filtre - Kit Montage
NS	98552C	Kit - Retro Filter Mounting	Montaje de Filtro Kit - Retro	Montage de Retro - Kit Filtre
NS	1000001813	Kit - Tower/Basin Gasket	Kit - Torre/Cuenca Junta	Kit - Tour/Collecteur

REPAIR SERVICE INFORMATION TOLL FREE NUMBER 1.800.260.6640
NÚMERO GRATIS DE SERVICIO 1.800.260.6640
INFORMATIONS POUR LE SERVICE PAR NUMERO SANS FRAIS 1.800.260.6640

FOR PARTS, CONTACT YOUR LOCAL DISTRIBUTOR OR CALL 1.800.323.0620
PARA PIEZAS, CONTACTE A SU DISTRIBUIDOR LOCAL O LLAME AL 1.800.323.0620
POUR OBTENIR DES PIÈCES, CONTACTEZ VOTRE DISTRIBUTEUR LOCAL OU COMPOSEZ LE 1.800.323.0620

PRINTED IN U.S.A.
IMPRESO EN LOS E.E.U.U.
IMPRIMÉ AUX É.-U.

ELKAY MANUFACTURING COMPANY • 2222 CAMDEN COURT • OAK BROOK, IL 60523 • 630.574.8484