

# Classic Washfountain

## Parts & Service Guide

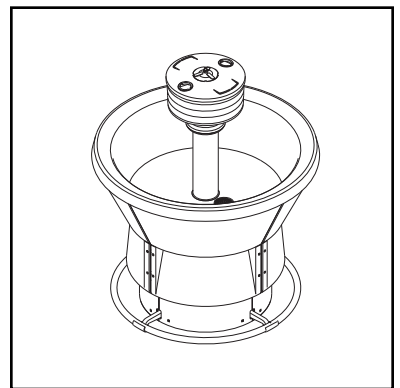

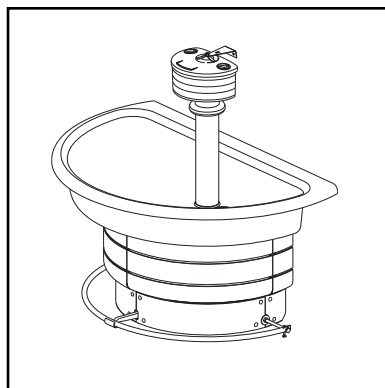
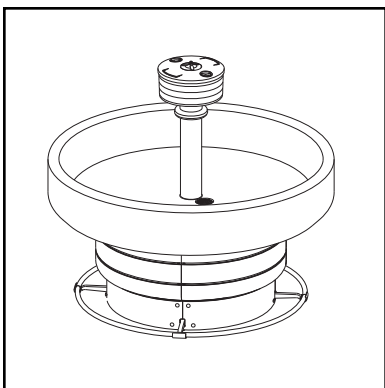
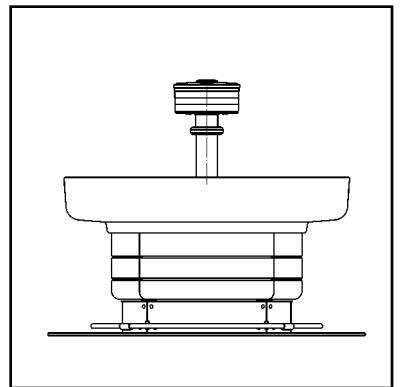
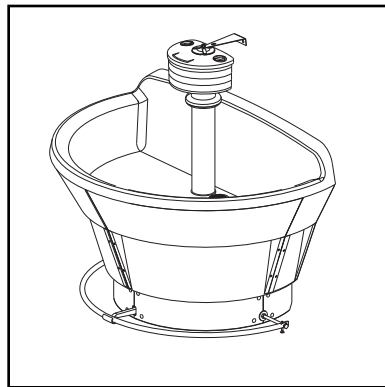
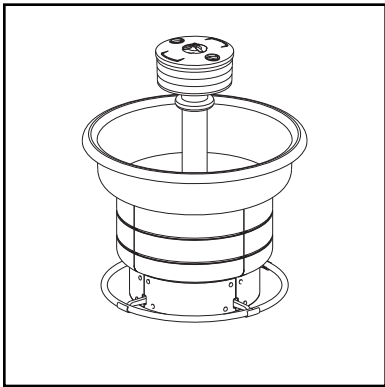

# Table of Contents

	<b>Page #</b>
<b>Washfountain Identification</b>	
Identification Charts and Model Numbers .....	4-5
How to Determine Drain Type .....	6
<b>Classic Washfountains</b>	
Washfountain Fittings — Type A Drain - Foot Control (Semi-Circular shown) .....	7-8
Washfountain Fittings — Type H Drain - Foot Control (Semi-Circular shown) .....	9-10
Washfountain Fittings — Type O Drain - Foot Control (Semi-Circular shown) .....	11-12
Washfountain Fittings — Type B Drain - Foot Control (Semi-Circular shown) .....	13-14
Bowls — Replacement Part Numbers .....	15
Pedestals — Circular Washfountains .....	16
Pedestals — Semi-Circular Washfountains .....	17-18
Pedestals — Corner Washfountains .....	19
Panels — Circular Pedestal Panels for Stainless Steel, Terrazzo, and Terreon® Bowls .....	20
Panels — Semi-Circular Pedestal Panels for Terrazzo and Terreon Bowls .....	21
Panels — Semi-Circular Pedestal Panels for Stainless Steel Bowls .....	22
Panels — Pedestal Panels for Bradstone Bowls .....	23
Panels — Corner Washfountain Stainless Steel Pedestal Panels .....	24
Linkage — Circular Washfountain Foot Control .....	25
Linkage — Semi-Circular Washfountain Foot Control .....	26
Linkage — Corner Washfountain Foot Control .....	27
Paper Towel Dispensers — Circular Washfountains .....	28
Paper Towel Dispensers — Circular Washfountains with Shroud .....	29
Paper Towel Dispensers — Semi-Circular Washfountains .....	30
Paper Towel Dispensers — Semi-Circular Washfountains with Shroud .....	31
Restraining Brackets .....	32
Foot Valve and Linkage (January 2003 to present) .....	33
Foot Valve and Linkage (November 1973 to January 2003) .....	34
Foot Valve Adjustment (November 1973 to January 2003) .....	35
Stop, Strainer, and Check Valve .....	36
Adjusting the Vernatherm™ Mixing Valve (August, 2004 to Present) .....	37-39
Mixing Valve — Vernatherm™ — Thermostatic (Prior to Aug, 2004) .....	40
Mixing Valve — Manual .....	41
Volume Control Valve Repair Parts — S02-0245 .....	42
Sprayheads — Standard w/Neoprene Spray Ring Grommet .....	43
Sprayhead Service Suggestions .....	43
Sprayhead Tubing Connections .....	44
Soap Valve — Liquid — S09-007S .....	45
Soap Valve — Lotion — S09-057S .....	45
Soap Valve — Powdered — S09-010A .....	46
Soap Maintenance Tips .....	47
Table of Contents .....	<i>Continued on Page 3</i>



**Table of Contents ....Continued**

**Electronic Activation**

Infrared Module — AccuZone® Circular & Semi (Terrazzo and Stainless Steel Bowls, Bradstone Bowls Prior to September 2003) .....48

Infrared AccuZone Valve Assembly — Circular & Semi (Terrazzo and Stainless Steel Bowls, Bradstone Bowls Prior to September 2003) .....49

Infrared AccuZone Wiring — Circular & Semi (Terrazzo and Stainless Steel Bowls, Bradstone Bowls Prior to September 2003) .....49

Troubleshooting AccuZone Infrared .....50

Infrared Module — Adaptive — Circular & Semi (Terreon, Bradstone Bowls from September 2003 to Present) .....51

Infrared Adaptive Valve Assembly — Circular (Terreon, Bradstone Bowls from September 2003 to Present) .....52

Infrared Adaptive Valve Assembly — Semi-Circular

Infrared Adaptive Wiring — Circular (Terreon, Bradstone Bowls from September 2003 to Present) .52 (Terreon®, Bradstone Bowls from September 2003 to Present) .....52

Infrared Adaptive Wiring — Semi-Circular (Terreon®, Bradstone Bowls from September 2003 to Present) .....53

Toubleshooting Adaptive Infrared .....54

Touch Time™ Module — Circular & Semi .....55

Touch Time™ Valve Assembly — Circular & Semi .....56

Touch Time™ Wiring — Circular .....57

Touch Time™ Wiring — Semi-Circular .....58

Troubleshooting Touch Time™ .....59

**Elctrical Activation — Common Parts List**

Solenoid Parts Breakdown .....60

Solenoid Parts Breakdown (Prior to March 20, 2002) .....61

Solenoid Troubleshooting .....62

**Mechanical Activation**

Air Valve Module — Circular & Semi .....63

Air Valve Valve Assembly — Circular .....64

Air Valve Valve Assembly — Semi-Circular .....65

Air Valve Tubing Connection .....66

Air Valve, Adjusting the Metering Time .....63

Air Valve Troubleshooting .....67

**Conversion Kits (Non Sectional)**

S50-311 Converts Circular Foot Control to AccuZone Infrared ..... (See Instruction Sheet 215-840)

S50-310 Converts Semi-Circular Foot Control to AccuZone Infrared ... (See Instruction Sheet 215-840)

**Conversion Kits Sectional)**

S50-322 Converts 36" Semi-Circular Foot Control to AccuZone Infrared .... (See Instruction Sheet 215-889)

S50-321 Converts 54" Semi-Circular Foot Control to AccuZone Infrared .... (See Instruction Sheet 215-889)

S50-320 Converts 36" Circular Foot Control to AccuZone Infrared ..... (See Instruction Sheet 215-889)

S50-319 Converts 54" Circular Foot Control to AccuZone Infrared ..... (See Instruction Sheet 215-889)



# Classic Washfountain Products

## Terrazzo

– Infrared, Touch Time, Air Valve or Foot Operated

- 9" deep bowl (cement with limestone chips)
- Available in Granito, White Marmorite, Dusty Rose, and Whisper Gray
- Stainless pedestal panels

### Models Available:

- WF2603 36" semi-circular
- WF2604 54" semi-circular
- WF2605 36" circular
- WF2608 54" circular
- WF2613 54" corner (Not shown)

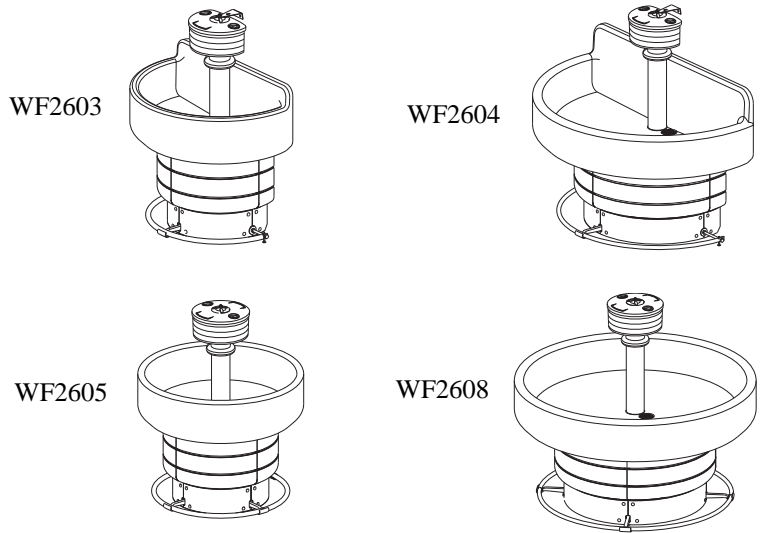

## Stainless Steel

– Infrared, Touch Time, Air Valve or Foot Operated

- 9" deep bowl
- Stainless steel bowl and pedestal panels

### Models Available:

- WF2703 36" semi-circular
- WF2704 54" semi-circular
- WF2705 36" circular
- WF2708 54" circular

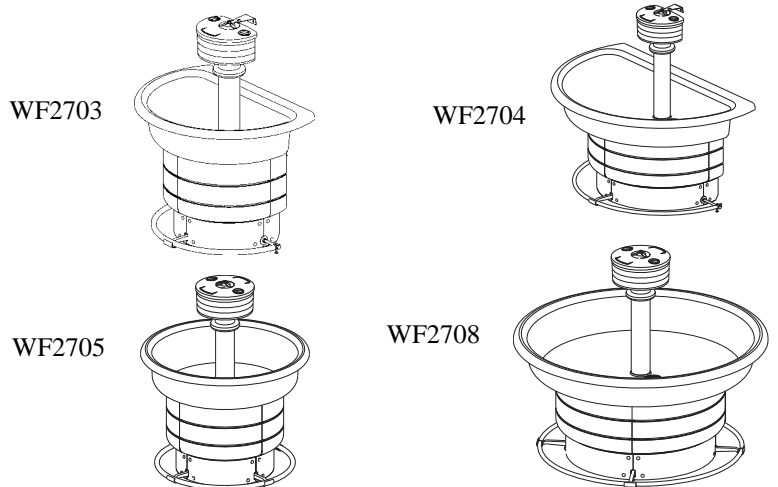

## Bradstone

– Infrared, Touch Time, Air Valve or Foot Operated

- 9" deep bowl (reinforced polyester resin)
- Available in Driftwood Beige and White Marble
- ABS tapered pedestal panels

### Models Available:

- WF2803 36" semi-circular
- WF2804 54" semi-circular
- WF2805 36" circular
- WF2808 54" circular

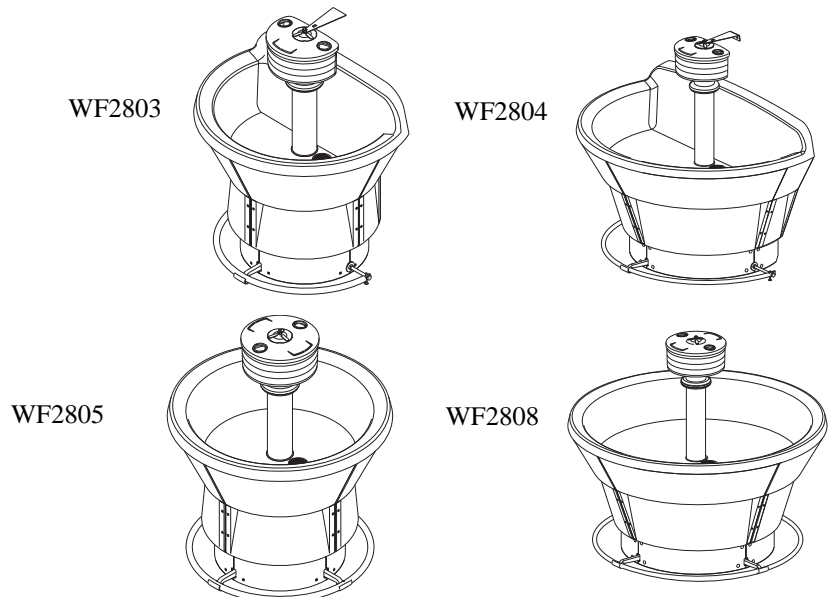



# Terreon® Washfountain Products

## Terreon® Classic

- 9" deep bowl (Solid Surface)
- Shares pedestal and most components with Classic Terrazzo
- Available in soapstone gray and canyon tan colors
- Stainless pedestal panels
- Standard Rim Height 29-1/2"

### Models Available:

- WF2503 36" semi-circular
- WF2504 54" semi-circular
- WF2505 36" circular
- WF2508 54" circular

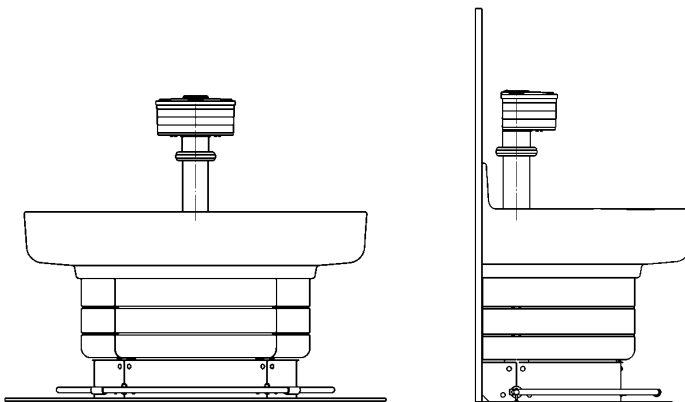

## Extra-Height Terreon® Classic (Parts not shown in this book)

- 9" deep bowl (same as Terreon® Classic), 34" rim height (36" semi-circular model has 35" rim height)
- Shares all components except the bowl with the Terreon® Deep Bowl
- Available in soapstone gray and canyon tan colors
- Gel-coated fiber-glass pedestal

### Models Available:

- WF3203 36" semi-circular
- WF3204 54" semi-circular
- WF3208 54" circular

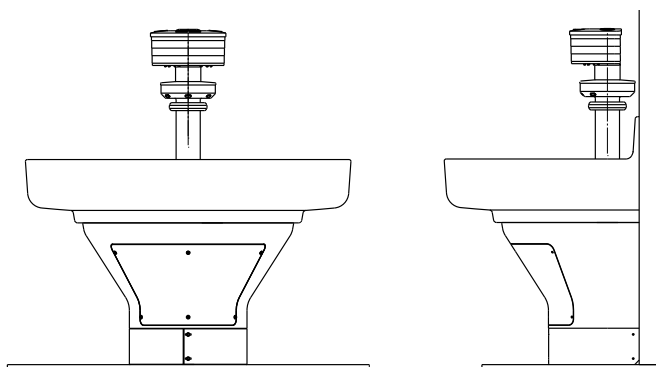

## Terreon® Deep Bowl (Parts not shown in this book)

- ADA compliant models available
- Shares all components except the bowl with the Terreon® Extra Height Classic Series
- Available in all colors except soapstone gray and canyon tan
- Standard Rim Height 34"

### Models Available:

- TDB3103 36" semi-circular
- TDB3104 54" semi-circular
- TDB3108 54" circular

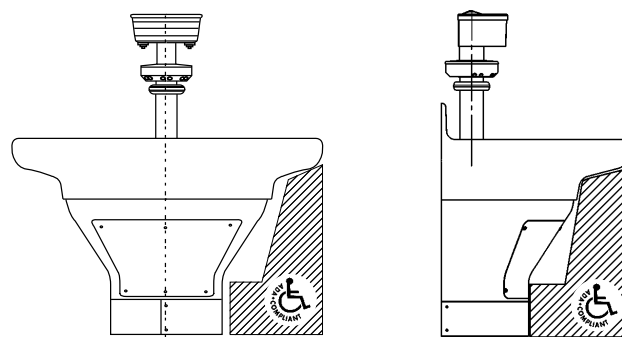

# How to Determine Drain Type

**(Parts may vary depending upon drain type. Identify your drain type before continuing.)**

## Type A

Off-line vent with supplies from below.

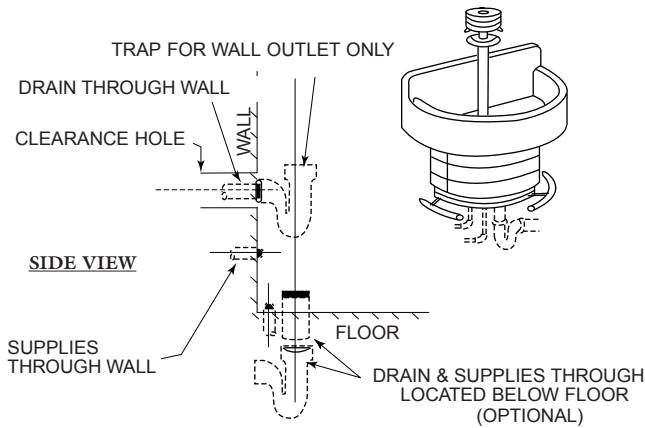

## Type O

Off-line vent with supplies from above.

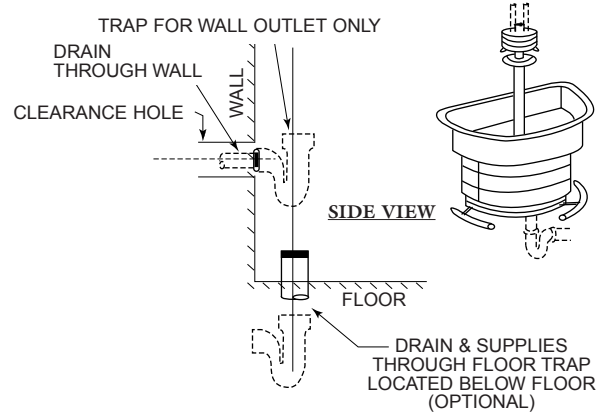

## Type B

Centrally rising vent with supplies from above.

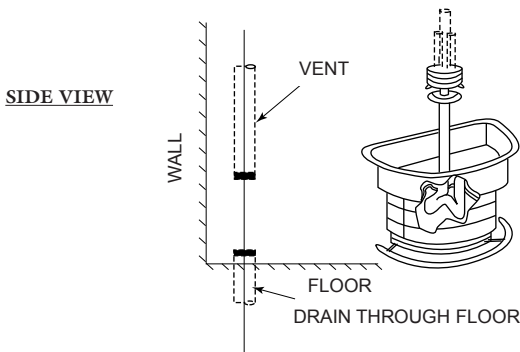

## Type H

Centrally rising vent with supplies from below.

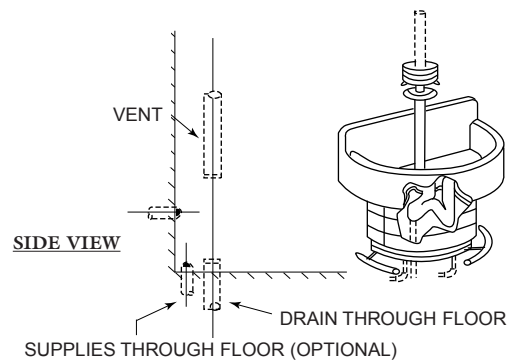



# Washfountain Fittings

## Type A Drain – Foot Control – (Semi-Circular shown)

Complete Soap Assemblies			
Items 2 through 10 comprise a complete soap dispenser assembly. For a complete assembly, order as follows:			
S11-144	Nylon LSD	—	Semi-circular
S11-153	Nylon PSD	—	Semi-circular
S11-180	Metal LSD	—	Semi-circular
S11-189	Metal PSD	—	Semi-circular
S11-126	Nylon LSD	—	Circular
S11-135	Nylon PSD	—	Circular
S11-162	Metal LSD	—	Circular
S11-171	Metal PSD	—	Circular

For washfountains without soap dispensers, delete items 4 through 10.

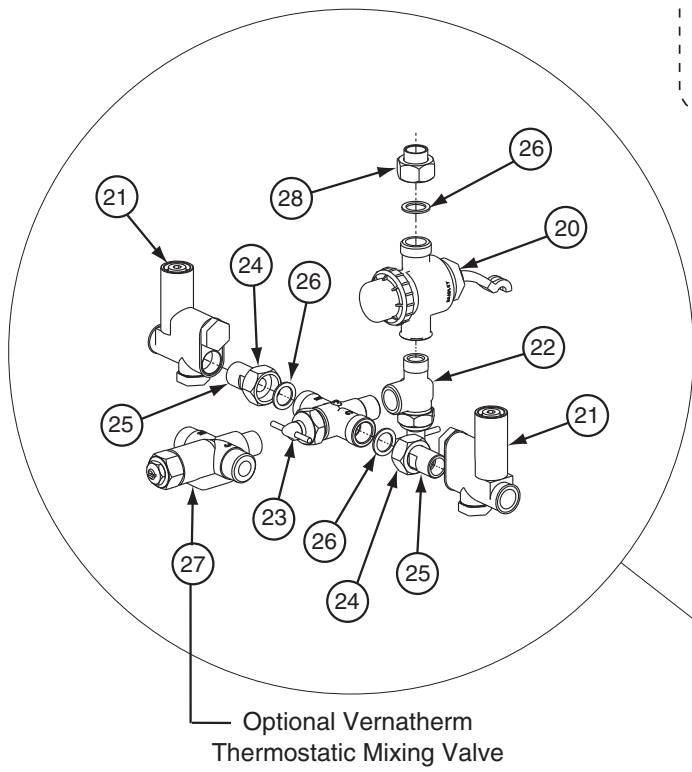
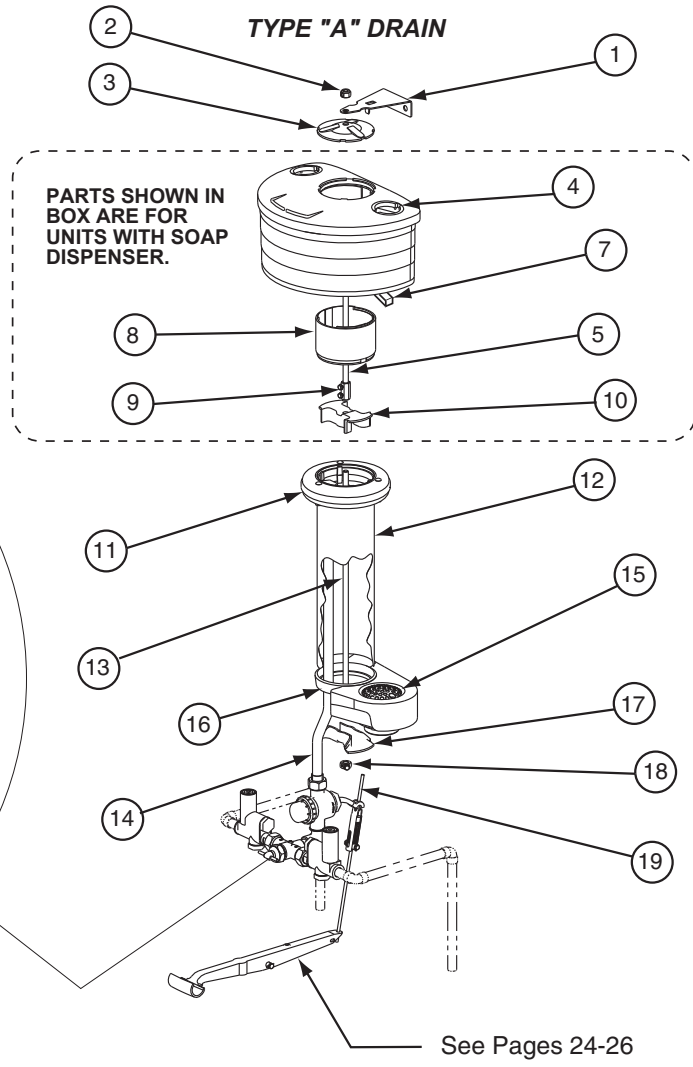

Parts List on next page



## Washfountain Fittings ....Continued

### Type A Drain – Foot Control

### Parts List

See previous page for panel item listing

Item	Part No.	Description	Semi & Corner		Circle	
			54" Qty	36" Qty	54" Qty	36" Qty
1	See Page 32	Restraining Bracket	1	1	—	—
2	S66-002	Locking Cap Nut	1	1	1	1
3	107-099	Dispenser Cover – Type A	1	1	1	1
4	S10-004	Nylon Filler Cap	2	2	2	2
5	176-010	Upper Tie Rod	1	1	1	1
7	S09-010A	Powdered Soap Valve	2	2	4	4
**	S09-007S	Liquid Soap Valve – Brass	2	2	4	4
8	113-155A	Nylon Support Tube Spacer	1	1	1	1
9	S66-001	Locking Coupling Nut	1	1	1	1
10	159-009A	Upper Tie Bar	1	1	1	1
11	S05-054B	Sprayhead, Semi-Circle Units	1	1	—	—
11	S05-054C	Sprayhead, Corner Units	1	—	—	—
11	S05-054	Sprayhead, Circular Units	—	—	1	1
12	S57-005	Sprayhead Support Tube	1	—	1	—
12	S57-006	Sprayhead Support Tube	—	1	—	1
13	176-008A	Lower Tie Rod	1	—	1	—
13	176-008	Lower Tie Rod	—	1	—	1
14	113-125A	Supply Pipe, Terrazzo or Terreon® Bowl	1	—	1	—
14	113-124A	Supply Pipe, Terrazzo or Terreon® Bowl	—	1	—	1
14	113-123A	Supply Pipe, Stainless Steel Bowl	1	—	1	—
14	113-122A	Supply Pipe, Stainless Steel or Bradstone Bowl	—	1	—	1
14	113-245	Supply Pipe, Bradstone Bowl	1	—	1	—
15	173-002	Strainer	1	1	1	1
**	160-044	Strainer Screw	2	2	2	2
**	112-015	Drain Spud, Terrazzo, Terreon® or Bradstone Bowl	1	1	1	1
**	112-016	Drain Spud, Stainless Steel Bowl	1	1	1	1
**	142-068	Washer	1	1	1	1
**	161-021	Drain Spud Lock Nut	1	1	1	1
16	125-008	Support Tube Gasket, Stainless Steel Bowl	1	1	1	1
16	125-011	Support Tube Gasket, All Other Bowls	1	1	1	1
17	159-009	Lower Tie Bar	1	1	1	1
18	S66-003	Locking Hex Nut	1	1	1	1
19	S14-007	Operating Rod Assy., Std. Ht.	1	1	1	1
19	S14-007A	Operating Rod Assy., Juv. Ht.	1	1	1	1
20	S07-066	Foot Valve	1	1	1	1
•21	S60-003	Combination, Stop, Strainer, and Check Valve	2	2	2	2
**	159-019	Operating Cross	—	—	1	1
22	S02-045	Volume Control Valve	1	1	1	1
•23	S01-038	Manual Mixing Valve	1	1	1	1
24	110-005	Tail Piece Nut	3	3	3	3
25	129-007	Tail Piece – Unplated	2	2	2	2
26	124-001AF	Tail Piece Washer – Fiber	3	3	3	3
•27	S01-525	Vernatherm Assy. — Thermostatic Mixing Valve	1	1	1	1
28	129-009	Foot Valve Tail Piece	1	1	1	1

• If any of these valves are desired complete with tail pieces, tail piece nuts and washers, order as follows:  
S60-003S, S01-038S, S01-522S

\*\* Not Illustrated.





# Washfountain Fittings

## Type H Drain – Foot Control – (Semi-Circular shown)

### Complete Soap Assemblies

Items 1 through 8 comprise a complete soap dispenser assembly. For a complete assembly, order as follows:

S11-152	Nylon LSD	—	Semi-circular
S11-161	Nylon PSD	—	Semi-circular
S11-188	Metal LSD	—	Semi-circular
S11-197	Metal PSD	—	Semi-circular
S11-134	Nylon LSD	—	Circular
S11-143	Nylon PSD	—	Circular
S11-170	Metal LSD	—	Circular
S11-179	Metal PSD	—	Circular

For washfountains without soap dispensers, delete items 4 through 8.

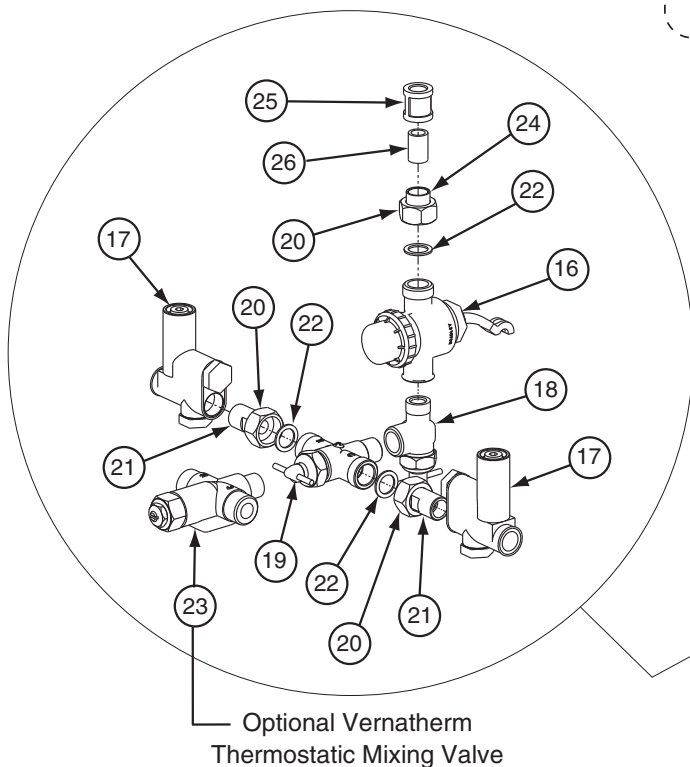
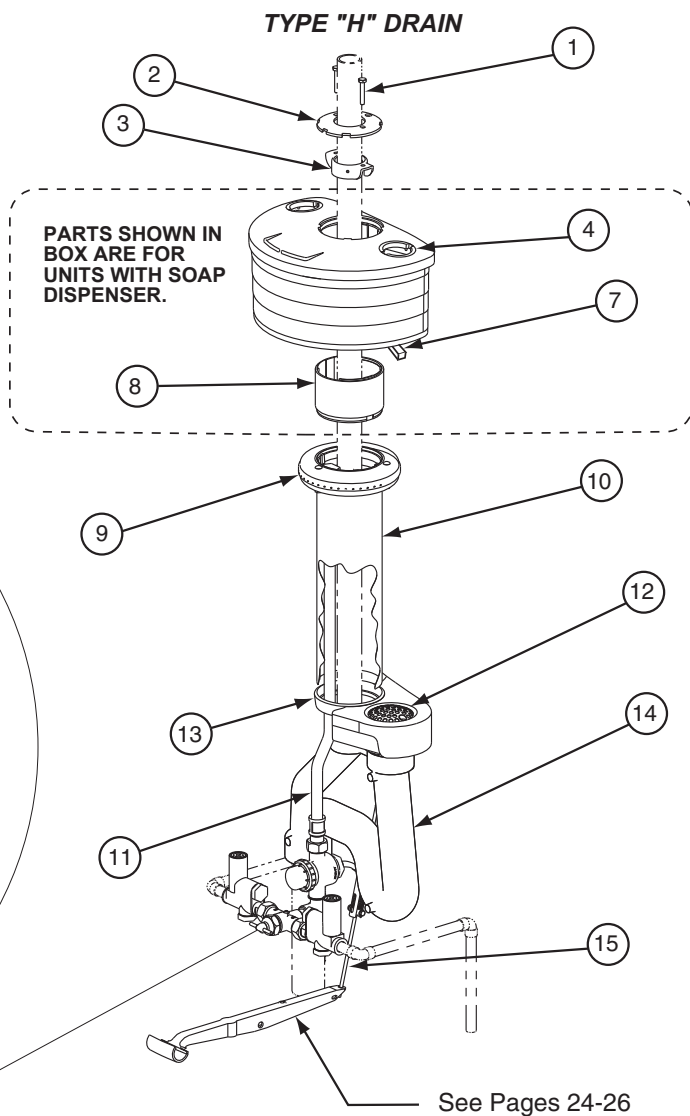

Parts List on next page



## Washfountain Fittings ....Continued

### Type H Drain – Foot Control

#### Parts List

See previous page for panel item listing

Item	Part No.	Description	Semi & Corner		Circle	
			54" Qty	36" Qty	54" Qty	36" Qty
1	160-108	Cap Screw	2	2	2	2
2	107-048	Dispenser Cover – Type H	1	1	1	1
3	159-020	Tie Bar	1	1	1	1
4	S10-004	Nylon Filler Hole Cap	2	2	2	2
7	S09-010A	Powdered Soap Valve	2	2	4	4
**	S09-007S	Liquid Soap Valve – Brass	2	2	4	4
8	113-155A	Nylon Support Tube Spacer	1	1	1	1
9	S05-054B	Sprayhead, Semi-Circle Units	1	1	—	—
9	S05-054C	Sprayhead, Corner Units	1	—	—	—
9	S05-054	Sprayhead, Circular Units	—	—	1	1
10	S57-005	Sprayhead Support Tube	1	—	1	—
10	S57-006	Sprayhead Support Tube	—	1	—	1
11	113-125A	Supply Pipe, Terrazzo or Terreon® Bowl	1	—	1	—
11	113-124A	Supply Pipe, Terrazzo or Terreon® Bowl	—	1	—	1
11	113-123A	Supply Pipe, Stainless Steel Bowl	1	—	1	—
11	113-122A	Supply Pipe, Stainless Steel or Bradstone Bowl	—	1	—	1
11	113-245	Supply Pipe, Bradstone Bowl	1	—	—	—
12	173-002	Strainer	1	1	1	1
**	160-044	Strainer Screw	2	2	2	2
**	112-015	Drain Spud, Terrazzo, Terreon® or Bradstone Bowl	1	1	1	1
**	112-016	Drain Spud, Stainless Steel Bowl	1	1	1	1
**	142-068	Washer	1	1	1	1
**	161-021	Drain Spud Lock Nut	1	1	1	1
13	125-008	Support Tube Gasket, Stainless Steel Bowl	1	1	1	1
13	125-011	Support Tube Gasket, All Other Bowls	1	1	1	1
14	111-024	Vented Trap	1	1	1	1
15	S14-007	Operating Rod Assy., Std. Ht.	1	1	1	1
15	S14-007A	Operating Rod Assy., Juv. Ht.	1	1	1	1
16	S07-066	Foot Valve	1	1	1	1
•17	S60-003	Combination, Stop, Strainer, and Check Valve	2	2	2	2
**	159-019	Operating Cross	—	—	1	1
18	S02-045	Volume Control Valve	1	1	1	1
•19	S01-038	Manual Mixing Valve	1	1	1	1
20	110-005	Tail Piece Nut	3	3	3	3
21	129-007	Tail Piece	2	2	2	2
22	124-001AF	Tail Piece Washer – Fiber	3	3	3	3
•23	S01-525	Vernatherm Assy. — Thermostatic Mixing Valve	1	1	1	1
24	129-009	Foot Valve Tail Piece	1	1	1	1
25	169-174	3/8" Coupling	1	1	1	1
26	113-852	Nipple 2" Long, Std Height	1	1	1	1
26	113-006AL	Close Nipple, Juv Height	1	1	1	1

• If any of these valves are desired complete with tail pieces, tail piece nuts and washers, order as follows:  
S60-003S, S01-038S, S01-522S

\*\* Not Illustrated.



# Washfountain Fittings

## Type O Drain – Foot Control – (Semi-Circular shown)

Complete Soap Assemblies			
Items 2 through 8 comprise a complete soap dispenser assembly. For a complete assembly, order as follows:			
S11-147	Nylon LSD	—	Semi-circular
S11-156	Nylon PSD	—	Semi-circular
S11-183	Metal LSD	—	Semi-circular
S11-192	Metal PSD	—	Semi-circular
S11-129	Nylon LSD	—	Circular
S11-138	Nylon PSD	—	Circular
S11-165	Metal LSD	—	Circular
S11-174	Metal PSD	—	Circular

For washfountains without soap dispensers, delete items 4 through 10.

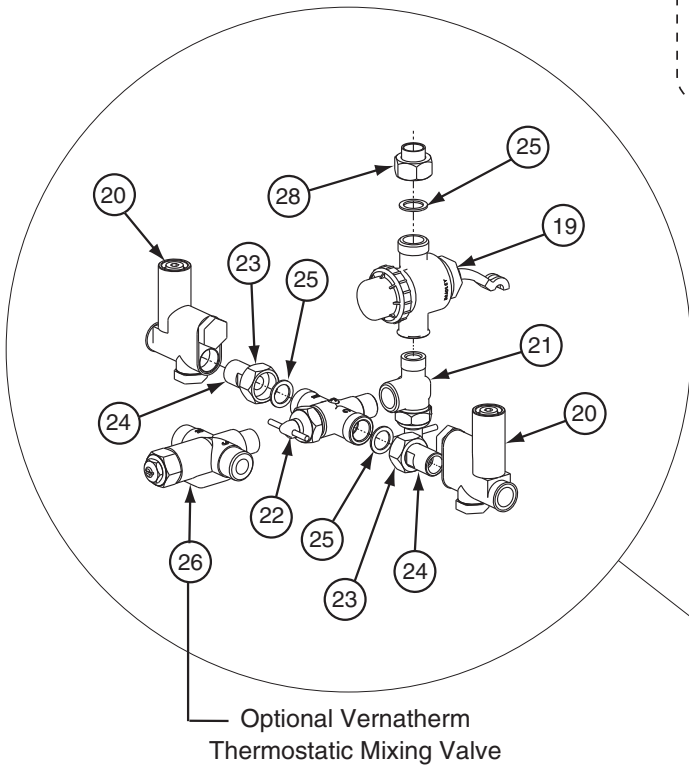
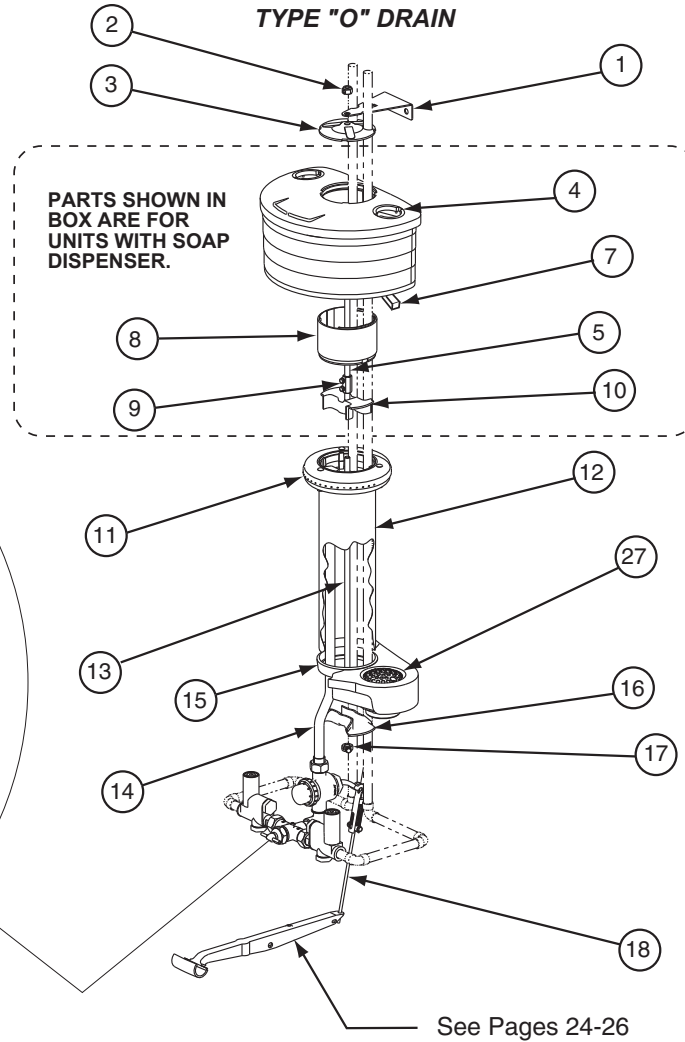

Parts List on next page



## Washfountain Fittings ....Continued

### Type O Drain – Foot Control

#### Parts List

See previous page for panel item listing

Item	Part No.	Description	Semi & Corner		Circle	
			54" Qty	36" Qty	54" Qty	36" Qty
1	See Page 32	Restraining Bracket	1	1	—	—
2	S66-002	Locking Cap Nut	1	1	1	1
3	107-179	Dispenser Cover – Type O	1	1	1	1
4	S10-004	Nylon Filler Cap	2	2	2	2
5	176-010	Upper Tie Rod	1	1	1	1
7	S09-010A	Powdered Soap Valve	2	2	4	4
**	S09-007S	Liquid Soap Valve – Brass	2	2	4	4
8	113-155A	Nylon Support Tube Spacer	1	1	1	1
9	S66-001	Locking Coupling Nut	1	1	1	1
10	159-009A	Upper Tie Bar	1	1	1	1
11	S05-054B	Sprayhead, Semi-Circle Units	1	1	—	—
11	S05-054C	Sprayhead, Corner Units	1	—	—	—
11	S05-054	Sprayhead, Circular Units	—	—	1	1
12	S57-005	Sprayhead Support Tube	1	—	1	—
12	S57-006	Sprayhead Support Tube	—	1	—	1
13	176-008A	Lower Tie Rod	1	—	1	—
13	176-008	Lower Tie Rod	—	1	—	1
14	113-125A	Supply Pipe, Terrazzo or Terreon® Bowl	1	—	1	—
14	113-124A	Supply Pipe, Terrazzo or Terreon® Bowl	—	1	—	1
14	113-123A	Supply Pipe, Stainless Steel Bowl	1	—	1	—
14	113-122A	Supply Pipe, Stainless Steel, Terreon® or Bradstone Bowl	—	1	—	1
14	113-245	Supply Pipe, Bradstone Bowl	1	—	1	—
15	125-008	Support Tube Gasket, Stainless Steel Bowl	1	1	1	1
15	125-011	Support Tube Gasket, All Other Bowls	1	1	1	1
16	159-009	Lower Tie Bar	1	1	1	1
17	S66-003	Locking Hex Nut	1	1	1	1
18	S14-007	Operating Rod Assy., Std. Ht.	1	1	1	1
18	S14-007A	Operating Rod Assy., Juv. Ht.	1	1	1	1
19	S07-066	Foot Valve	1	1	1	1
•20	S60-003	Combination, Stop, Strainer, and Check Valve	2	2	2	2
**	159-019	Operating Cross	—	—	1	1
21	S02-045	Volume Valve	1	1	1	1
•22	S01-038	Manual Mixing Valve	1	1	1	1
23	110-005	Tail Piece Nut	3	3	3	3
24	129-007	Tail Piece	2	2	—	—
25	124-001AF	Tail Piece Washer – Fiber	3	3	3	3
•26	S01-525	Vernatherm Assy. — Thermostatic Mixing Valve	1	1	1	1
27	173-002	Strainer	1	1	1	1
**	160-044	Strainer Screw	2	2	2	2
**	112-015	Drain Spud, Terrazzo, Terreon® or Bradstone Bowl	1	1	1	1
**	112-016	Drain Spud, Stainless Steel Bowl	1	1	1	1
**	142-068	Washer	1	1	1	1
**	161-021	Drain Spud Lock Nut	1	1	1	1
28	129-009	Foot Valve Tail Piece	1	1	1	1

• If any of these valves are desired complete with tail pieces, tail piece nuts and washers, order as follows:  
S60-003S, S01-038S, S01-522S

\*\* Not Illustrated.



# Washfountain Fittings

## Type B Vent – Foot Control – (Semi-Circular shown)

Complete Soap Assemblies			
Items 1 through 8 comprise a complete soap dispenser assembly. For a complete assembly, order as follows:			
S11-150	Nylon LSD	—	Semi-circular
S11-159	Nylon PSD	—	Semi-circular
S11-186	Metal LSD	—	Semi-circular
S11-195	Metal PSD	—	Semi-circular
S11-132	Nylon LSD	—	Circular
S11-141	Nylon PSD	—	Circular
S11-168	Metal LSD	—	Circular
S11-177	Metal PSD	—	Circular

For washfountains without soap dispensers, delete items 4 through 8.

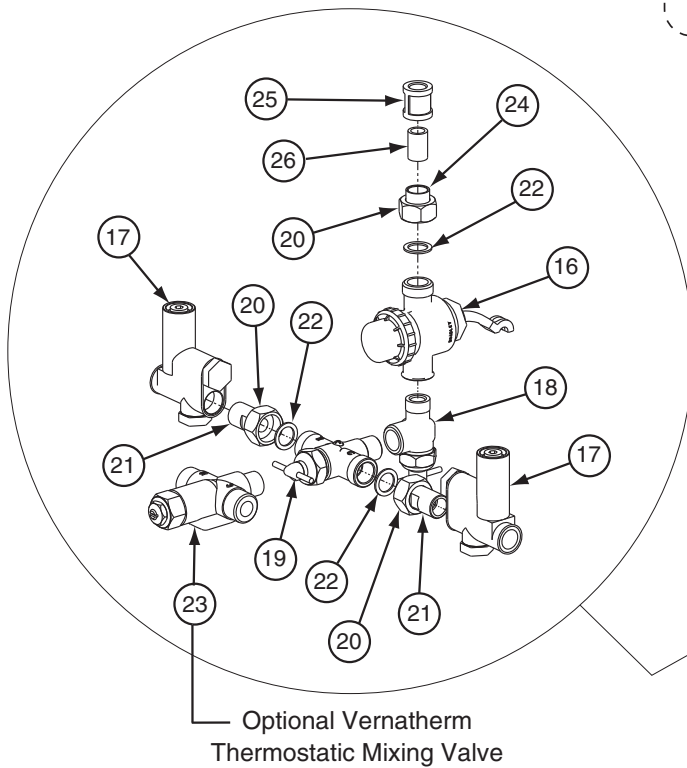
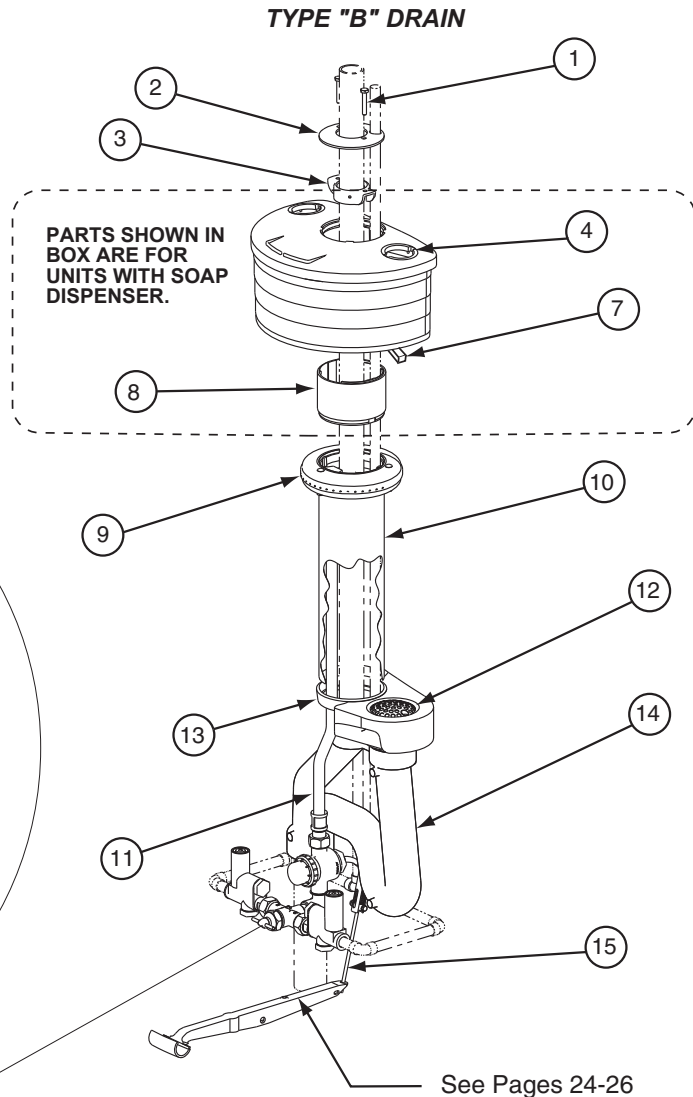

Parts List on next page



## Washfountain Fittings ....Continued

### Type B Drain – Foot Control

#### Parts List

See previous page for panel item listing

Item	Part No.	Description	Semi & Corner		Circle	
			54" Qty	36" Qty	54" Qty	36" Qty
1	160-108	Cap Screw	2	2	2	2
2	107-185	Dispenser Cover – Type B	1	1	1	1
3	159-020	Tie Bar	1	1	1	1
4	S10-004	Nylon Filler Hole Cap	2	2	2	2
7	S09-010A	Powdered Soap Valve	2	2	4	4
**	S09-007S	Liquid Soap Valve – Brass	2	2	4	4
8	113-155A	Nylon Support Tube Spacer	1	1	1	1
9	S05-054B	Sprayhead, Semi-Circle Units	1	1	—	—
9	S05-054C	Sprayhead, Corner Units	1	1	—	—
9	S05-054	Sprayhead, Circular Units	—	—	1	1
10	S57-005	Sprayhead Support Tube	1	—	1	—
10	S57-006	Sprayhead Support Tube	—	1	—	1
11	113-125A	Supply Pipe, Terrazzo or Terreon® Bowl	1	—	1	—
11	113-124A	Supply Pipe, Terrazzo or Terreon® Bowl	—	1	—	1
11	113-123A	Supply Pipe, Stainless Steel Bowl	1	—	1	—
11	113-122A	Supply Pipe, Stainless Steel, Terreon® or Bradstone Bowl	—	1	—	1
11	113-245	Supply Pipe, Bradstone Bowl	1	—	1	—
12	173-002	Strainer	1	1	1	1
**	160-044	Strainer Screw	2	2	2	2
**	112-015	Drain Spud, Terrazzo, Terreon® or Bradstone Bowl	1	1	1	1
**	112-016	Drain Spud, Stainless Steel Bowl	1	1	1	1
**	142-068	Washer	1	1	1	1
**	161-021	Drain Spud Lock Nut	1	1	1	1
13	125-008	Support Tube Gasket, Stainless Steel Bowl	1	1	1	1
13	125-011	Support Tube Gasket, All Other Bowls	1	1	1	1
14	111-024	Vented Trap	1	1	1	1
15	S14-007	Operating Rod Assy., Std. Ht.	1	1	1	1
15	S14-007A	Operating Rod Assy., Juv. Ht.	1	1	1	1
16	S07-066	Foot Valve	1	1	1	1
•17	S60-003	Combination, Stop, Strainer, Check Valve	2	2	2	2
**	159-019	Operating Cross	—	—	1	1
18	S02-045	Volume Control Valve	1	1	1	1
•19	S01-038	Manual Mixing Valve	1	1	1	1
20	110-005	Tail Piece Nut	3	3	3	3
21	129-007	Tail Piece Unplated	2	2	2	2
22	124-001AF	Tail Piece Washer – Fiber	3	3	3	3
•23	S01-525	Vernatherm Assy. — Thermostatic Mixing Valve	1	1	1	1
24	129-009	Foot Valve Tail Piece	1	1	1	1
25	169-174	3/8" Coupling	1	1	1	1
26	113-852	Nipple 2" Long, Std Height	1	1	1	1
26	113-006AL	Close Nipple, Juv Height	1	1	1	1

• If any of these valves are desired complete with tail pieces, tail piece nuts and washers, order as follows:  
S60-003S, S01-038S, S01-522S

\*\* Not Illustrated.



## Bowls — Replacement Part Numbers

### Terreon® Replacement Bowls

Part No.	Configuration	Color
S45-1952AA	54" Semi-Circular Bowl	Soapstone Gray
S45-1952AB	54" Semi-Circular Bowl	Canyon Tan
S45-1977AA	36" Semi-Circular Bowl	Soapstone Gray
S45-1977AB	36" Semi-Circular Bowl	Canyon Tan
S45-1962AA	54" Circular Bowl	Soapstone Gray
S45-1962AB	54" Circular Bowl	Canyon Tan
S45-1965AA	36" Circular Bowl	Soapstone Gray
S45-1965AB	36" Circular Bowl	Canyon Tan

### Attaching Brackets For Terreon Bowls

Part No.	Configuration	Color
*S45-1932	Semi-Circular	
*S45-1933	Circular	

\* These brackets are required when replacing terrazzo Bowls with Terreon® (no other bowls are directly interchangeable).

### Terrazzo Replacement Bowls

Part No.	Configuration	Color
S16-070	54" Semi-Circular Bowl	Granito
S16-071	54" Semi-Circular Bowl	White Marmorite
S16-074	36" Semi-Circular Bowl	Granito
S16-075	36" Semi-Circular Bowl	White Marmorite
S16-066	54" Circular Bowl	Granito
S16-067	54" Circular Bowl	White Marmorite
S16-072	36" Circular Bowl	Granito
S16-073	36" Circular Bowl	White Marmorite
*S16-013	54" Corner Bowl	Granito
*S16-013D	54" Corner Bowl	White Marmorite

\* Foot rails are included with corner bowls.

### Stainless Steel Replacement Bowls

Part No.	Configuration	Color
S18-634	54" Semi-Circular Bowl	N/A
S18-636	36" Semi-Circular Bowl	N/A
S18-633	54" Circular Bowl	N/A
S18-635	36" Circular Bowl	N/A

### Bradstone Replacement Bowls

Part No.	Configuration	Color
S38-067	54" Semi-Circular Bowl	Sandbox
S38-068	54" Semi-Circular Bowl	Carbon
S38-071	36" Semi-Circular Bowl	Sandbox
S38-072	36" Semi-Circular Bowl	Carbon
S38-065	54" Circular Bowl	Sandbox
S38-066	54" Circular Bowl	Carbon
S38-069	36" Circular Bowl	Sandbox
S38-070	36" Circular Bowl	Carbon



## Pedestals — Circular Washfountains

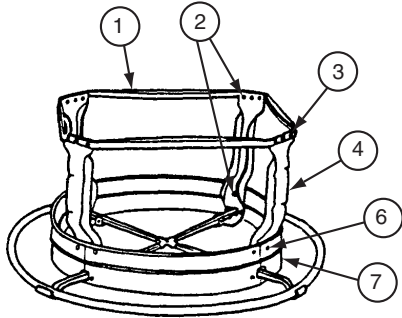

FOR STANDARD PANELS  
Fits Terrazzo and Stainless Steel bowls

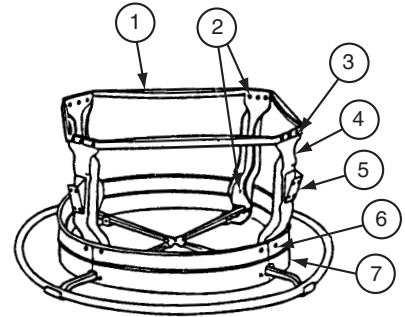
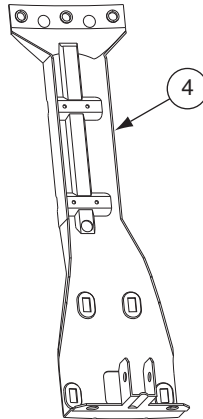

FOR TAPERED PANELS  
Fits Bradstone bowls only

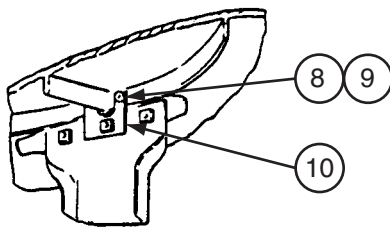

FOR BRADSTONE BOWL ONLY

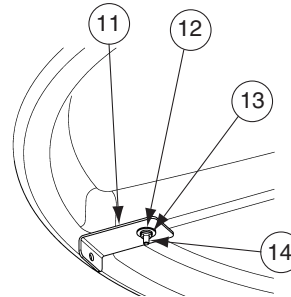

FOR TERREON BOWL ONLY

**NOTE:** Foot control linkage shown in illustrations is not part of pedestal. See specific parts sheet for identification.

## Parts List

Item	Part No.	Description	54"	36"
			Qty	
1	194-005	Frame Member	4	—
1	194-006	Frame Member	—	4
2	161-040	Nut	28	28
3	160-104	Stove Bolt	12	12
4	193-002	Leg, Standard Height	4	4
4	193-002B	Leg, Juvenile Height	4	4
5	140-291	Panel Bracket, Bradstone Bowl only	4	—
*	160-320	Panel Screw	28	16
*	142-002CA	Taper Panel Screw Washer, Bradstone only	16	16
6	160-060A	Carriage Bolt, Plated	16	16
7	185-015A	Scuff Base	4	—
7	185-016A	Scuff Base	—	4
8	160-069	Screw, Bradstone Bowl only	8	8
9	161-047	Nut, Bradstone Bowl only	8	8
10	140-141	Bracket, Bradstone Bowl only	4	4
11	140-747	Bracket — Terreon Bowl only	4	4
12	142-002BJ	Washer, Round — Terreon Bowl only	8	8
13	142-002X	Washer, Split — Terreon Bowl only	4	4
14	161-076	Nut — Terreon Bowl only	4	4

\* Not Illustrated.





## Pedestals — Semi-Circular Washfountains

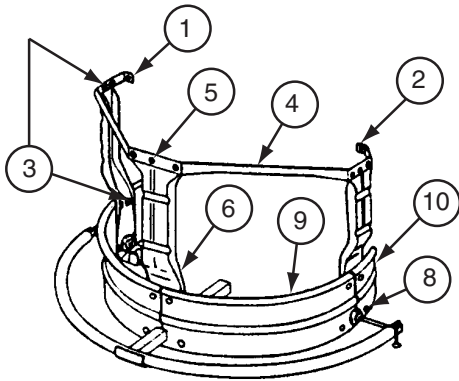

FOR STANDARD PANELS  
Fits Terrazzo and Stainless Steel bowls

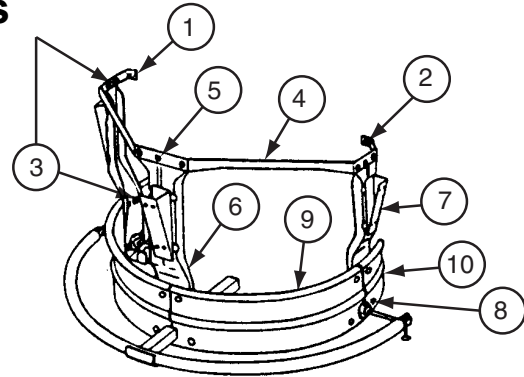
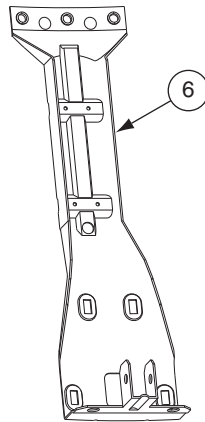

FOR TAPERED PANELS  
Fits Bradstone bowls only

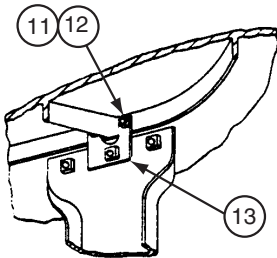

FOR BRADSTONE BOWL ONLY

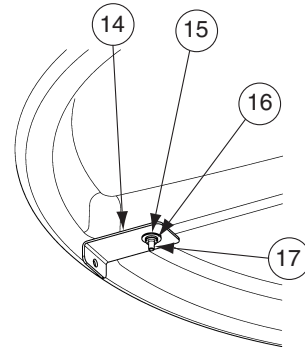

FOR TERREON BOWL ONLY

**NOTE:** Foot control linkage shown in illustrations is not part of pedestal. See specific parts sheet for identification.

### Parts List

Item	Part No.	Description	54"	36"
			Qty	
1	140-040LH	Wall Bracket, Terrazzo & Terreon® Bowl	1	—
2	140-040RH	Wall Bracket, Terrazzo & Terreon® Bowl	1	—
1	140-041LH	Wall Bracket, Terrazzo & Terreon® Bowl	—	1
2	140-041RH	Wall Bracket, Terrazzo & Terreon® Bowl	—	1
1	140-188LH	Wall Bracket, Stainless Steel & Bradstone Bowl	1	—
2	140-188RH	Wall Bracket, Stainless Steel & Bradstone Bowl	1	—
1	140-189LH	Wall Bracket, Stainless Steel & Bradstone Bowl	—	1
2	140-189RH	Wall Bracket, Stainless Steel & Bradstone Bowl	—	1
3	161-040	Nut For Frame Member, Scuff Base	21	21
4	194-005	Frame Member	2	—
4	194-006	Frame Member	—	2

\* Not Illustrated.

*Table continued on next page*



**Pedestals — Semi-Circular Washfountains...Continued**

**Parts List...Continued**

Item	Part No.	Description	54"	36"
			Qty	
5	160-104	Stove Bolt For Frame Member	9	9
6	193-002	Leg, Standard Height	3	3
*	193-002B	Leg, Juvenile Height	3	3
7	140-291	Panel Bracket, Bradstone only	3	—
8	160-060A	Carriage Bolt, Stainless Steel Scuff Base	12	12
9	185-015A	Scuff Base (All)	2	—
9	185-016A	Scuff Base (All)	—	2
10	S45-217A	Scuff Base Ends, Bradstone & Stainless Steel Bowl (Set R & L)	1	—
10	S45-227A	Scuff Base Ends, Bradstone & Stainless Steel Bowl (Set R & L)	—	1
10	S45-214A	Scuff Base Ends, Terrazzo & Terreon, Bowl (Set R & L)	1	—
10	S45-224A	Scuff Base Ends, Terrazzo & Terreon, Bowl (Set R & L)	—	1
11	160-069	Screw, Bradstone only	6	6
12	161-047	Nut, Bradstone Bowl only	6	6
13	140-141	Bracket Bradstone Bowl only	3	3
*	160-320	Panel Screw	21	12
*	142-002CA	Taper Panel Screw Washer, Bradstone only	12	12
14	140-747	Bracket — Terreon Bowl only	3	3
15	142-002BJ	Washer, Round — Terreon Bowl only	6	6
16	142-002X	Washer, Split — Terreon Bowl only	3	3
17	161-076	Nut — Terreon Bowl only	3	3

\* Not Illustrated.



# Pedestals — Corner Washfountains

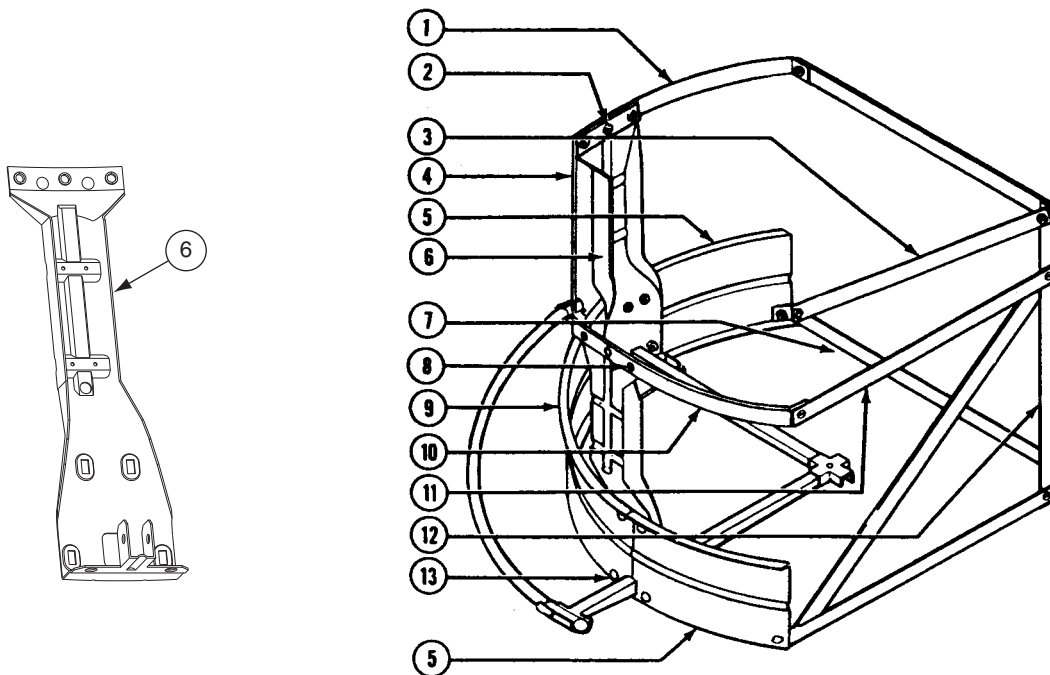

NOTE: Foot control linkage shown in illustrations is not part of pedestal. See specific parts sheet for identification.

## Parts List

Item	Part No.	Description	54"
			Qty
1	140-146LH	Wall Bracket	1
2	161-040	Nut	24
3	194-043	Diagonal Support, Standard Height	2
3	194-043A	Diagonal Support, Juvenile Height	2
4	194-005	Frame Member	1
5	S45-234A	Scuff Base Ends, (Set R & L)	1
6	193-002	Leg, Standard Height	2
6	193-002B	Leg, Juvenile Height	2
7	194-041	Lower Support	2
8	160-104	Stove Bolt	14
9	185-015A	Scuff Base	1
10	140-146RH	Wall Bracket	1
11	194-042	Upper Support	2
12	193-006	Corner Leg, Standard Height	1
12	193-006A	Corner Leg, Juvenile Height	1
13	160-060A	Carriage Bolt, Stainless Steel, Scuff base	10
*	160-320	Panel Screw	8

\* Not Illustrated.



# Panels — Circular Pedestal Panels for Stainless Steel, Terrazzo, and Terreon® Bowls

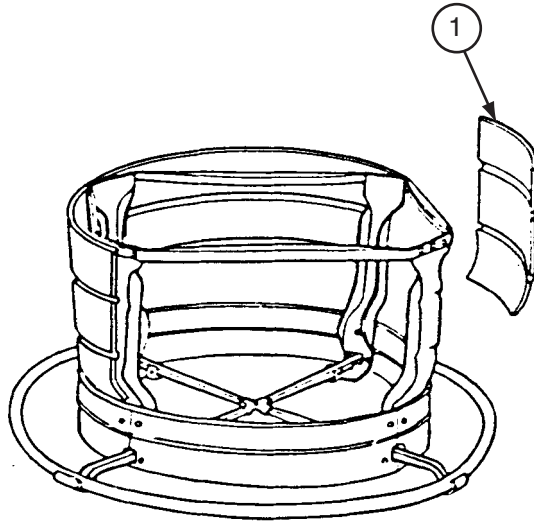

See Page 15 for panel screws.

## Parts List

Item	Part No.	Description	54"	36"
			Qty	
1	186-006A	Stainless Steel Center Panel	—	4
1	186-018A	Stainless Steel Juvenile Height Center Panel	—	4
1	186-005A	Stainless Steel Center Panel	4	—
1	186-016A	Stainless Steel Juvenile Height Center Panel	4	—



## Panels — Semi-Circular Pedestal Panels for Terrazzo and Terreon® Bowls

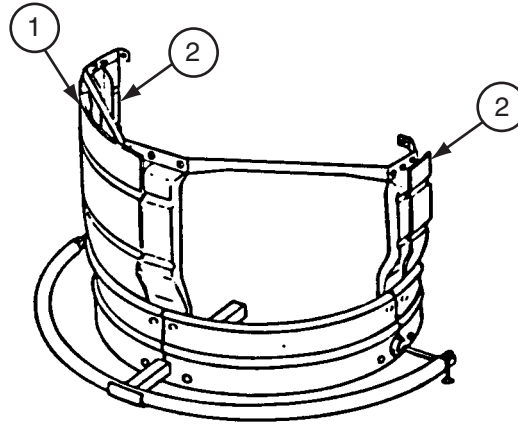

See Pages 17-18 for panel screws.

### Parts List

Item	Part No.	Description	54"	36"
			Qty	
1	186-006A	Stainless Steel Center Panel	—	2
2	S45-225A	Stainless Steel Rear Panels (Set R & L)	—	1
2	186-018A	Stainless Steel Juvenile Height Center Panel	—	2
2	S45-226A	Stainless Steel Juvenile Height Rear Panels (Set R & L)	—	1
1	186-005A	Stainless Steel Center Panel	2	—
2	S45-215A	Stainless Steel Rear Panels (Set R & L)	1	—
1	186-016A	Stainless Steel Juvenile Height Center Panel	2	—
2	S45-216A	Stainless Steel Juvenile Height Rear Panels (Set R & L)	1	—



# Panels — Semi-Circular Pedestal Panels for Stainless Steel Bowls

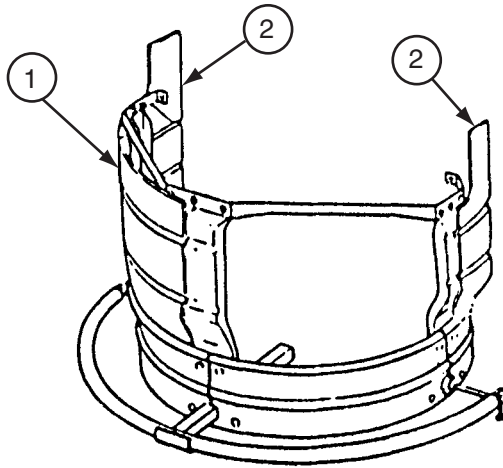

See Pages 17-18 for panel screws.

## Parts List

Item	Part No.	Description	54"	36"
			Qty	
1	186-006A	Stainless Steel Center Panel	—	2
2	S45-228A	Stainless Steel Rear Panels (Set R & L)	—	1
1	186-018A	Stainless Steel Juvenile Height Center Panel	—	2
2	S45-229A	Stainless Steel Juvenile Height Rear Panels (Set R & L)	—	1
1	186-005A	Stainless Steel Center Panel	2	—
2	S45-218A	Stainless Steel Rear Panels (Set R & L)	1	—
1	186-016A	Stainless Steel Juvenile Height Center Panel	2	—
2	S45-219A	Stainless Steel Juvenile Height Rear Panels (Set R & L)	1	—



## Panels — Pedestal Panels for Bradstone Bowls

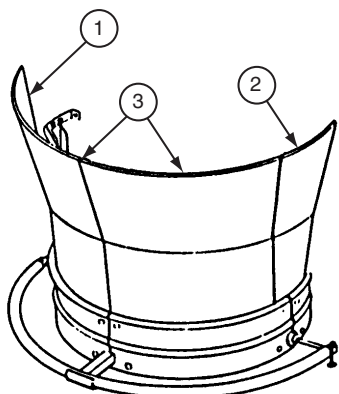

**Semi-Circular**

See Pages 17-18 for panel screws and washers.

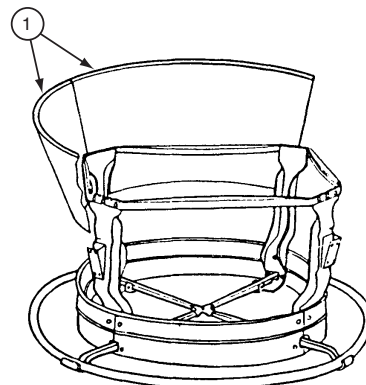

**Circular**

See Page 16 for panel screws and washers.

### Semi-Circular Parts List

Item	Part No.	Description	54"	36"
			Qty	
1	186-879	Left Rear Panel – Almond	—	1
1	186-879B	Left Rear Panel – Gray	—	1
2	186-880	Right Rear Panel – Almond	—	1
2	186-880B	Right Rear Panel – Gray	—	1
3	186-182A	Center Panel – Almond	—	2
3	186-182B	Center Panel – Gray	—	2
1	186-877	Left Rear Panel – Almond	1	—
1	186-877B	Left Rear Panel – Gray	1	—
2	186-878	Right Rear Panel – Almond	1	—
2	186-878B	Right Rear Panel – Gray	1	—
3	186-157A	Center Panel – Almond	2	—
3	186-157B	Center Panel – Gray	2	—

### Circular Parts List

Item	Part No.	Description	54"	36"
			Qty	
1	186-182A	Center Panel – Almond	—	4
1	186-182B	Center Panel – Gray	—	4
1	186-157A	Center Panel – Almond	4	—
1	186-157B	Center Panel – Gray	4	—



### Panels — Corner Washfountain Stainless Steel Pedestal Panels

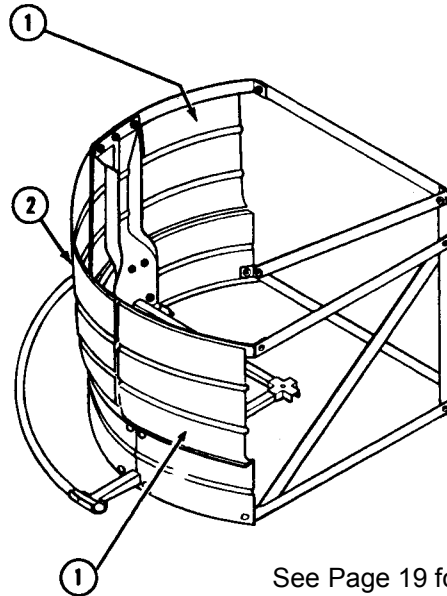

See Page 19 for panel screws.

### Parts List

Item	Part No.	Description	54"
			Qty
1	S45-235A	Stainless Steel Rear Panels (Set R & L)	1
2	186-005A	Stainless Steel Center Panel	1
1	S45-236A	Stainless Steel Juvenile Height Rear Panels (Set R & L)	1
2	186-016A	Stainless Steel Juvenile Height Center Panel	1





# Linkage — Circular Washfountain Foot Control

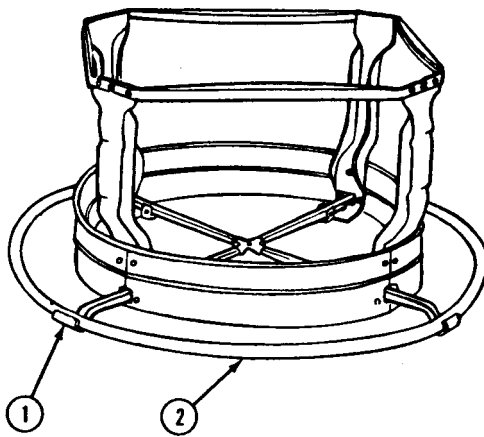

Note: \* Pedestal Leg shown on Pedestal drawings.

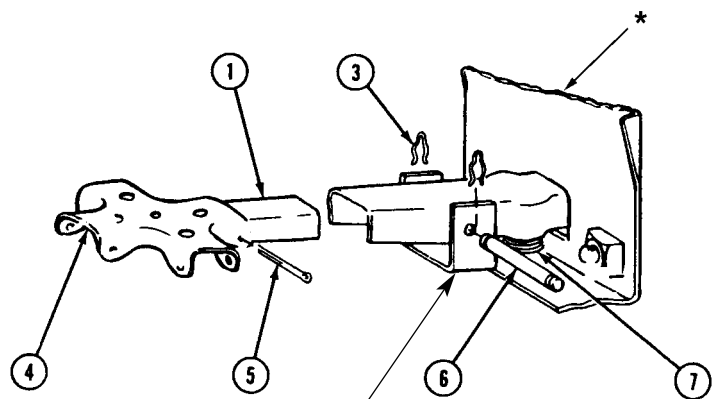

Note: U-bracket is part of pedestal leg.

## Parts List

Item	Part No.	Description	54"	36"
			Qty	
1	143-025	Foot Lever	4	—
1	143-027	Foot Lever	—	4
2	S25-016	Foot Rail Assembly	1	—
2	S25-015	Foot Rail Assembly	—	1
3	166-004	Spring Clip Fastener	8	8
4	159-019	Operating Cross	1	1
5	166-003	Cotter Pin	4	4
6	152-026	Pivot Pin	4	4
7	135-001W	Foot Lever Spring	4	4

NOTE: Items 3 through 7 are available in a Prep ack. Order Part number S45-003.



# Linkage — Semi-Circular Washfountain Foot Control

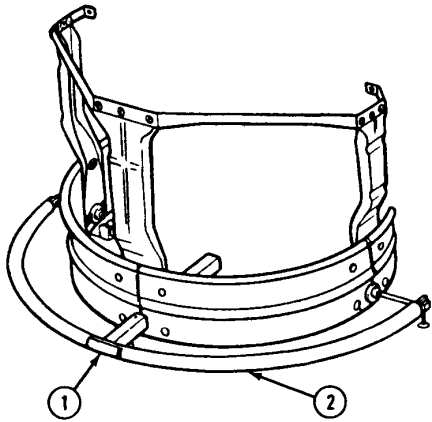

Note: \* Pedestal Leg shown on Pedestal drawings.

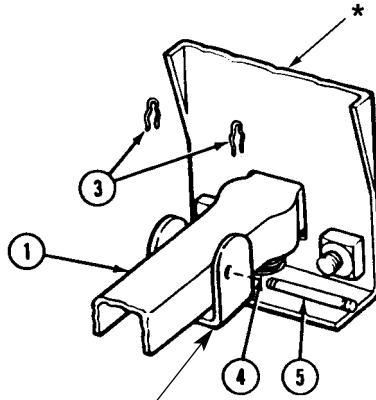

Note: U-bracket is part of pedestal leg.

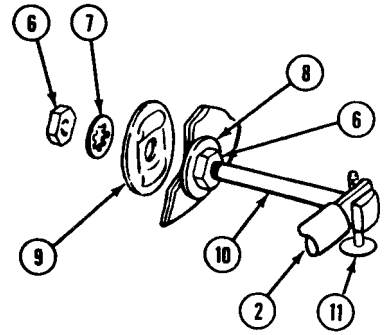

## Parts List

Item	Part No.	Description	54"	36"
			Qty	
1	143-025	Foot Lever	1	—
1	143-027	Foot Lever	—	1
2	S25-018	Foot Rail Assembly	1	—
2	S25-017	Foot Rail Assembly	—	1
3	166-004	Spring Clip Fastener	2	2
4	135-001W	Foot Lever Spring	1	1
5	152-026	Pivot Pin	1	1
6	161-007	Jam Nut	4	4
7	142-002BC	Shakeproof Washer	2	2
8	142-002AM	Flat Washer	2	2
9	142-020	Ribbed Washer	2	2
10	160-065	Pivot Bolt	2	—
10	160-043	Pivot Bolt	—	2
11	160-082	Elevator Bolt	2	2

NOTE: Items 3 through 11 are available in a Prepack. Order as follows:  
Part number S45-004 36" Washfountain  
Part number S45-004A 54" Washfountain



## Linkage — Corner Washfountain Foot Control

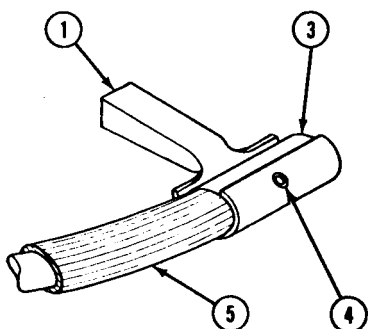

Note: \* Pedestal Leg shown on Pedestal drawings.

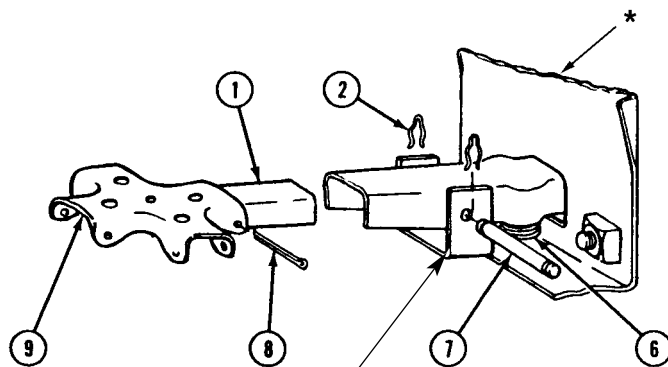

Note: U-bracket is part of pedestal leg.

### Parts List

Item	Part No.	Description	54"
			Qty
1	143-042	Foot Lever	2
2	166-004	Spring Clip Fastener	4
3	182-044	Spacer	2
4	152-036	Spring Pin	2
5	S25-021	Foot Rail Assembly	1
6	135-001W	Foot Lever Spring	2
7	152-026	Pivot Pin	2
8	166-003	Cotter Pin	2
9	159-019	Operating Cross	1



# Paper Towel Dispensers

## Circular Washfountains

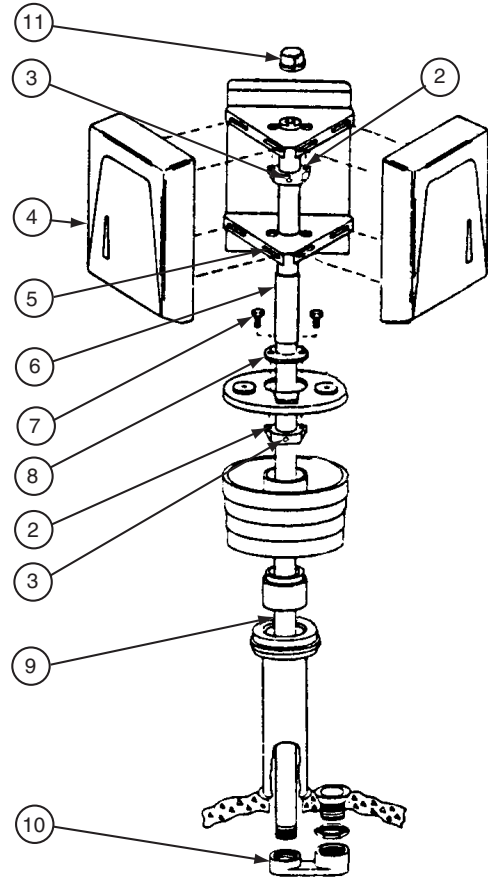

### Parts List

Item	Part No.	Description	54"	36"
			Qty	
❶ 2	159-020	Tie Bar	2	2
❶ 3	160-208	Tie Bar Screw, #10-24 x 3/8" Hex Head (Totals for 2 Tie Bars)	6	6
4	S78-001	Towel Dispenser, C-fold or multi-fold	3	3
*	S78-002	Towel Dispenser, Single fold	3	3
5	S70-123	Towel Dispenser Mounting Bracket	2	2
6	113-170	Shroud Tube (Washfountains w/Soap Dispenser)	1	1
*	113-168	Shroud Tube (Washfountains Less Soap Dispenser)	1	1
❶ 7	160-111	Cap Screw for Tie Bar, 1/4-20 x 1/2" Hex Head	4	4
8	107-048	Cover - Type "H" Drain or Type "A" w/ Towel Dispensers	1	1
8	107-185	Cover - Type "B" Drain or Type "O" w/ Towel Dispensers	1	1
9	—	Vent Pipe or Support Pipe (Not furnished by Bradley Corporation)	1	1
10	S70-082	Tie Pipe Bracket (Furnished only for washfountains without centrally rising vents)	1	1
❶ 11	169-986A	Pipe Cap (For washfountains without centrally rising vents)	1	1

❶ Prepack S45-205

\* Not Illustrated.



# Paper Towel Dispensers

## Circular Washfountains with Shroud

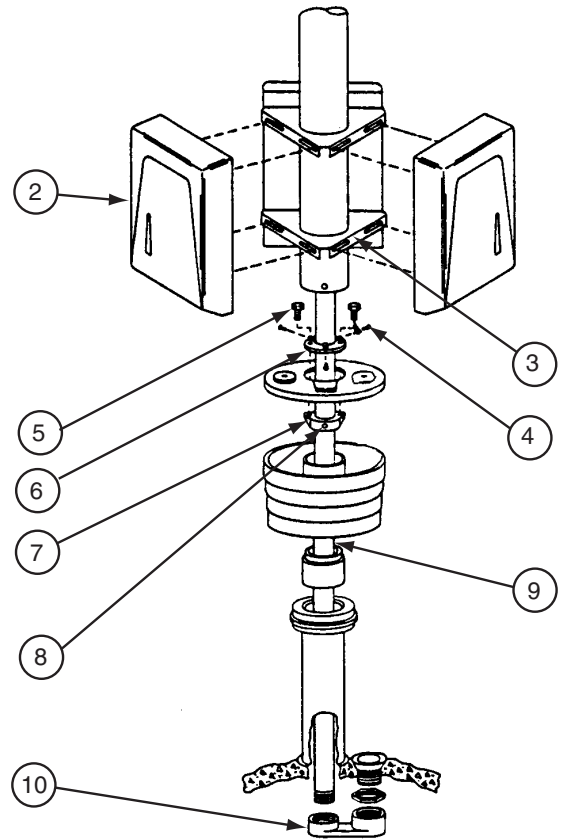

### Parts List

Item	Part No.	Description	54"	36"
			Qty	
2	S78-001	Towel Dispenser, C-fold or multi-fold	3	3
*	S78-002	Towel Dispenser, Single fold	3	3
3	S70-095	Towel Dispenser Mounting Bracket	2	2
*	160-169	Screw to Mount Brackets, 1/4-20 x 13/32" Round Head	6	6
4	160-138	Screw to attach shroud to cover, #10-24 x 1/2" Button Head	3	3
5	160-111	Cap Screw for Tie Bar, 1/4-20 x 1/2" Hex Head	2	2
6	S04-029	Cover for Soap Dispensers or Sprayhead, All Supply Types	1	1
7	159-020	Tie Bar	—	1
8	160-208	Tie Bar Screw, #10-24 x 3/8" Hex Head	3	3
9	—	Vent Pipe or Support Pipe (Not Furnished by Bradley Corporation)	1	1
10	S70-082	Tie Pipe Bracket Assembly (Furnished only for washfountains without centrally rising vents)	1	1

\* Not Illustrated.



## Paper Towel Dispensers Semi-circular Washfountains

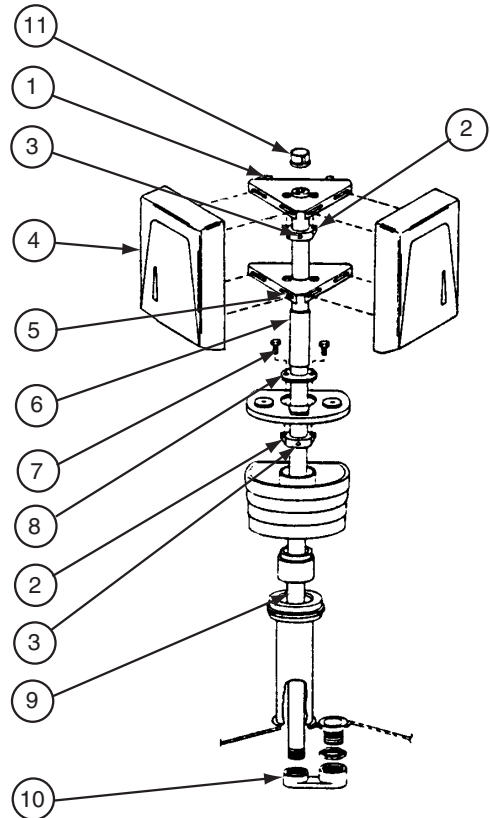

### Parts List

Item	Part No.	Description	54"	36"
			Qty	
1	140-212	Restraining Bracket, Terrazzo or Terreon® Bowl	—	2
1	140-212A	Restraining Bracket, Terrazzo or Terreon® Bowl	2	—
1	140-212B	Restraining Bracket, Stainless Steel or Bradstone Bowl	—	2
1	140-212C	Restraining Bracket, Stainless Steel or Bradstone Bowl	2	—
❶ 2	159-020	Tie Bar	2	2
❶ 3	160-208	Tie Bar Screw, #10-24 x 3/8" Hex Head (Totals for 2 Tie Bars)	6	6
4	S78-001	Towel Dispenser, C-fold or multi-fold	2	2
*	S78-002	Towel Dispenser, Single fold	2	2
5	S70-123	Towel Dispenser Mounting Bracket	2	2
6	113-170	Shroud Tube (Washfountains w/Soap Dispenser)	1	1
*	113-168	Shroud Tube (Washfountains Less Soap Dispenser)	1	1
❶ 7	160-111	Cap Screw for Tie Bar, 1/4-20 x 1/2" Hex Head	4	4
8	107-048	Cover - Type "H" Drain or Type "A" w/ Towel Dispensers	1	1
8	107-185	Cover - Type "B" Drain or Type "O" w/ Towel Dispensers	1	1
9	—	Vent Pipe or Support Pipe (Not furnished by Bradley Corporation)	1	1
10	S70-082	Tie Pipe Bracket (Furnished only for washfountains without centrally rising vents)	1	1
❶ 11	169-986A	Pipe Cap (For washfountains without centrally rising vents)	1	1

❶ Prepack S45-205

\* Not Illustrated.



# Paper Towel Dispensers

## Semi-circular Washfountains with Shroud

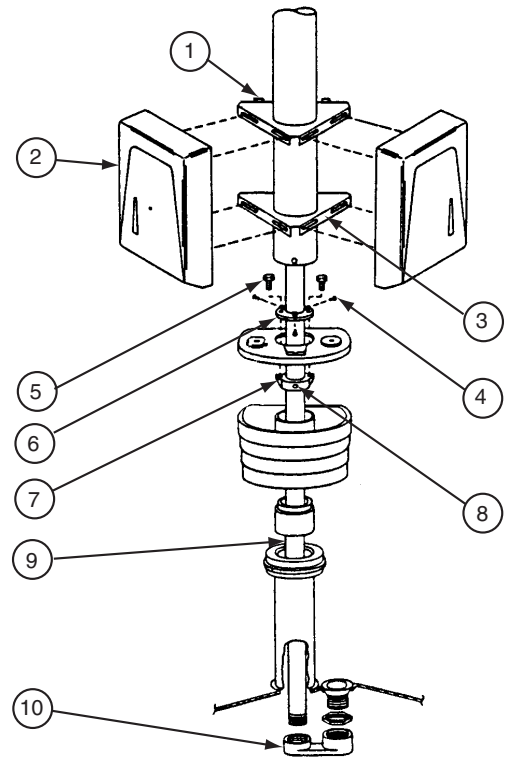

### Parts List

Item	Part No.	Description	54"	36"
			Qty	
1	140-212	Restraining Bracket, Terrazzo or Terreon® Bowl	—	2
1	140-212A	Restraining Bracket, Terrazzo or Terreon® Bowl	2	—
1	140-212B	Restraining Bracket, Stainless Steel or Bradstone Bowl	—	2
1	140-212C	Restraining Bracket, Stainless Steel or Bradstone Bowl	2	—
2	S78-001	Towel Dispenser, C-fold or multi-fold	3	3
*	S78-002	Towel Dispenser, Single fold	3	3
3	S70-095	Towel Dispenser Mounting Bracket	2	2
*	160-169	Screw to Mount Brackets, 1/4-20 x 13/32" Round Head	6	6
4	160-138	Screw to attach shroud to cover, #10-24 x 1/2" Button Head	3	3
❶ 5	160-111	Cap Screw for Tie Bar, 1/4-20 x 1/2" Hex Head	2	2
6	S04-029	Cover for Soap Dispensers or Sprayhead, All Supply Types	1	1
❶ 7	159-020	Tie Bar	1	1
❶ 8	160-208	Tie Bar Screw, #10-24 x 3/8" Hex Head	3	3
9	—	Vent Pipe or Support Pipe (Not Furnished by Bradley Corporation)	1	1
10	S70-082	Tie Pipe Bracket Assembly (Furnished Only for Washfountains Without Centrally Rising Vents)	1	1

❶ Prepack S45-205

\* Not Illustrated.



# Restraining Brackets

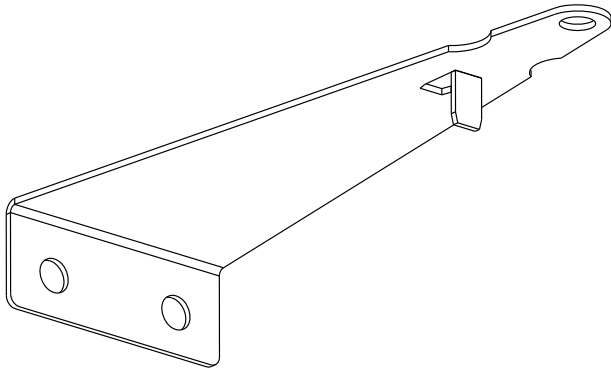

Semi-Circle

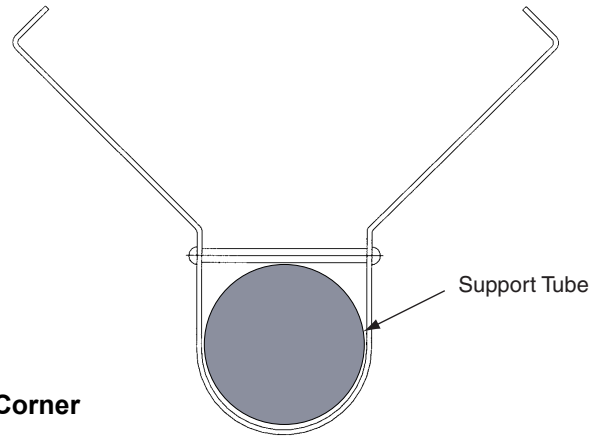

Corner

## Parts List

Part No.	Description	Qty
140-124	54" Bradstone and Stainless	1
140-126	54" Terrazzo and Terreon	1
140-196	36" Bradstone and Stainless	1
140-128	36" Terrazzo and Terreon	1
S70-061E	54" Terrazzo Corner	1

**NOTE:** B or H Drains do not require restraining bracket since 1-1/2" vent pipe provides additional support.





## Foot Valve (Jan. 2003 to present)

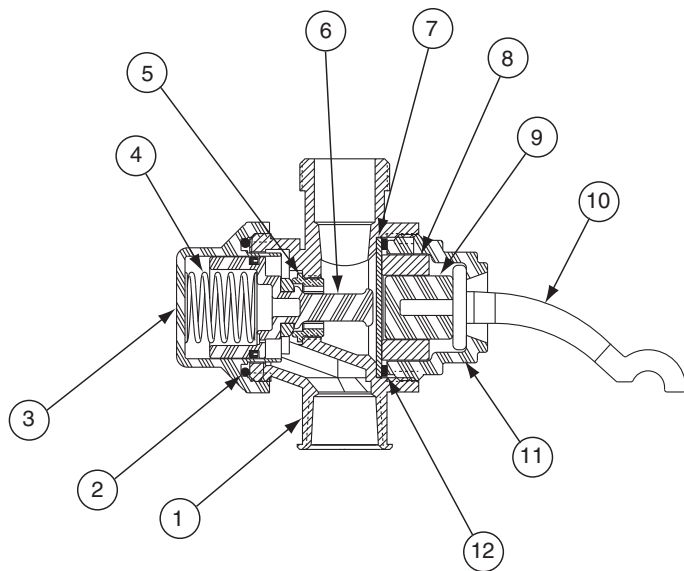

### Parts List S07-066 Foot Valve

Item	Part No.	Qty	Description
1	118-302	1	Foot Valve Body
2	125-154	1	O-Ring
3	118-300	1	Foot Valve Cover (blue)
4	135-088	1	Spring
5	117-016	1	Valve Seat
6	S64-093	1	Plunger Assembly
7	125-001Y	1	Diaphragm
8	179-002	1	Plunger Guide
9	119-024	1	Plunger
10	143-026	1	Operating Lever
11	110-101	1	Bottom Nut
12	124-001V	1	Washer - Black Phenolic

**NOTE:** This valve can be identified by the color of Item 3.

### Parts List S65-230 Foot Valve Repair Kit

Item	Part No.	Qty	Description
1	118-300	1	Foot Valve Cover
2	135-088	1	Spring
3	125-154	1	O-Ring
4	S64-093	1	Plunger Assembly
5	117-016	1	Valve Seat
6	125-001Y	1	Diaphragm
7	124-001V	1	Washer - Black Phenolic
8	130-033	1	Key-Valve Seat
9	S45-125	1	Lubricant (not shown)

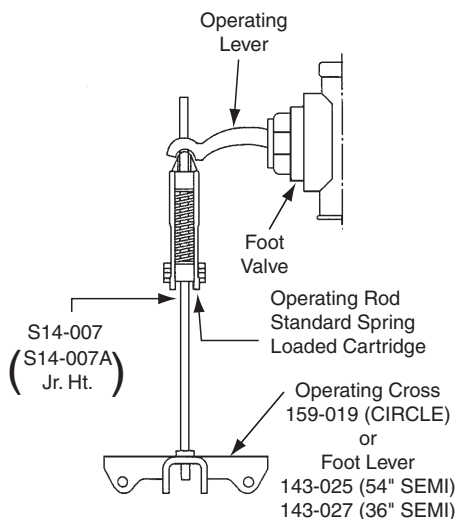
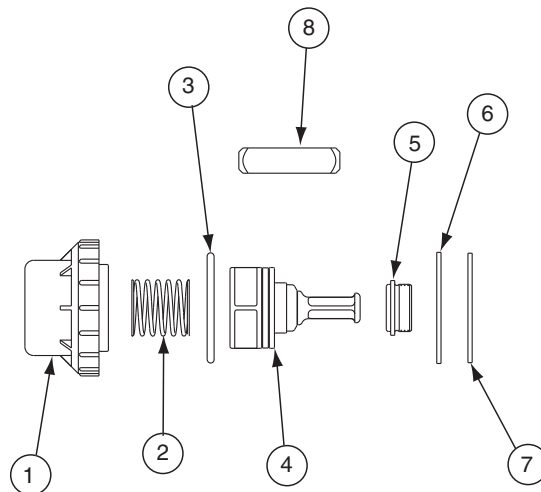

## Foot Valve Linkage

For normal operation using the standard operating rod assembly, the spring loaded cartridge should be adjusted so there is no play in the operating lever. Care must be taken to insure that a snug fit is achieved without engaging the operating lever, or water will leak from the sprayhead.



### Foot Valve (Nov. 1973 to Jan. 2003)

#### Parts List S07-015 Foot Valve

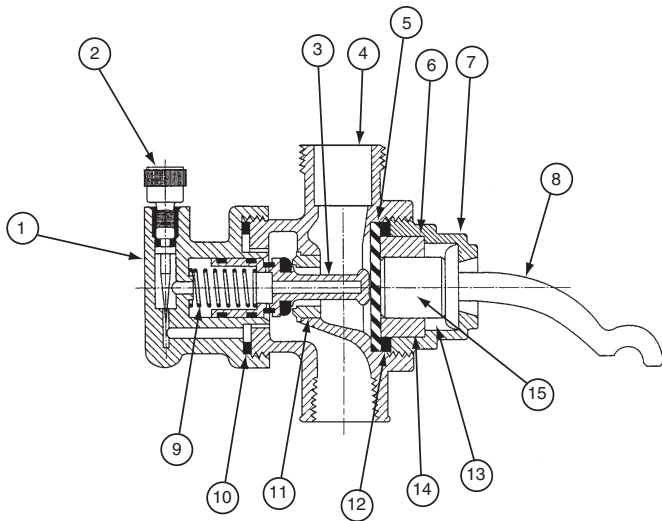

Item	Part No.	Qty	Description
1	110-095	1	Body-Needle Valve
2	S21-027	1	Needle Assembly
3	S64-006	1	Valve Plunger Assembly
*4	118-021	1	Valve Body (No longer available)
5	125-001Y	1	Diaphragm
6	179-002	1	Plunger Guide
7	110-101	1	Bottom Nut
8	143-026	1	Operating Lever
9	135-001P	1	Spring
10	125-001BW	1	Gasket
11	117-016	1	Renewable Valve Seat
12	124-001V	1	Washer Black Phenolic
13	119-024	1	Operating Plunger
14	179-002	1	Plunger Guide
15	119-024	1	Plunger

\* Valve body no longer available, replace with S07-066 (Complete Valve)

#### Parts List S65-001A Foot Valve Repair Kit

Item	Part No.	Qty	Description
1	S21-027	1	Needle Assembly
2	125-001BW	1	Gasket
3	S64-006	1	Valve Plunger Assembly
4	117-016	1	Valve Seat
5	125-001Y	1	Diaphragm
6	124-001V	1	Fiber Washer
7	110-095	1	Body-Needle Valve
8	135-001P	1	Spring
9	130-033	1	Key-Valve Seat

Repairs All Foot Valves Furnished Since April 1943 to Jan. 2003.

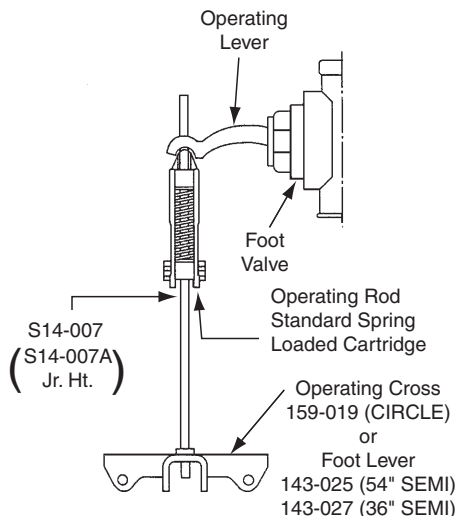
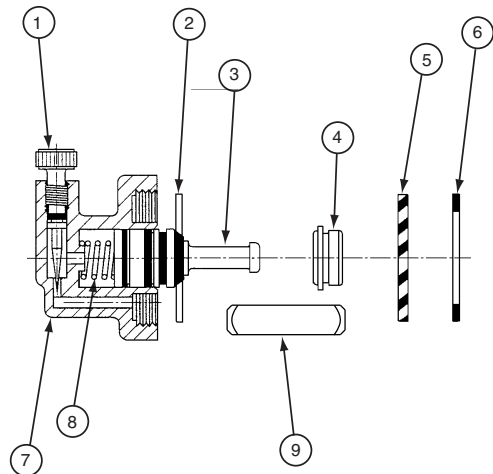

### Foot Valve Linkage

For normal operation using the standard operating rod assembly, the spring loaded cartridge should be adjusted so there is no play in the operating lever. Care must be taken to insure that a snug fit is achieved without engaging the operating lever, or water will leak from the sprayhead.



# Foot Valve Adjustment Instructions (November 1973 to Jan. 2003) (Valves made from Jan. 2003 to present require no adjustments)

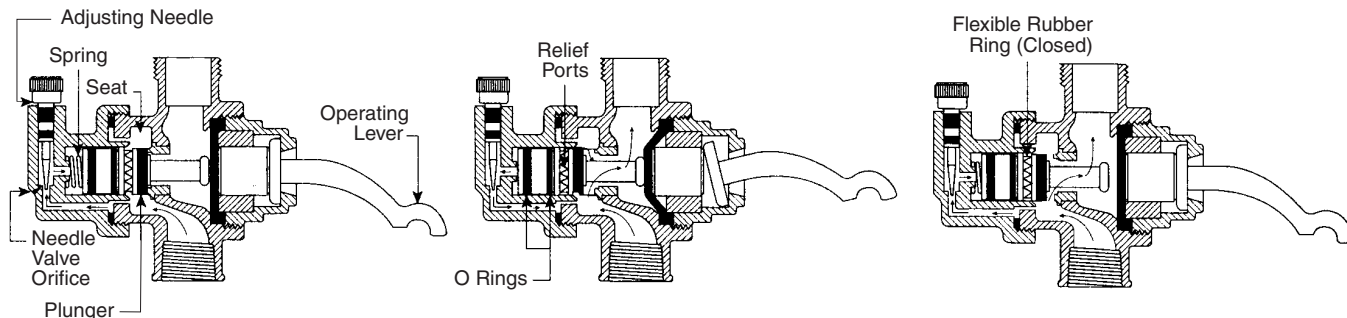

**I. CLOSED POSITION:  
PLUNGER SEATED.  
NO WATER FLOW.**

(Needle Valve is used to prevent water hammer)

**II. OPENING POSITION:**

- a) Valve actuated - plunger pushed off seat — water flows through seat to sprayhead.
- b) As opening cycle starts and water within the hollow plunger assembly is pushed out through restricted needle valve orifice, pressure is relieved through ports covered with flexible rubber ring, allowing valve to open easily. Rubber ring acts as check valve, preventing back flow through parts which would defeat slow closing feature of the valve.

**III. CLOSING POSITION:**

As operating lever is released, plunger moves back towards seat, pushed by the spring, but retarded by flow of water to sprayhead and vacuum created by displacement of water behind plunger. Bypass water moving through needle valve orifice fills vacuum and helps to return plunger to seat. Speed of closure controlled by volume of water allowed through needle valve.

The adjusting needle controls the closing, or shut off speed of valve. Turning the adjusting needle clockwise retards closing. This adjustment corrects water hammer problems. Turning the adjusting needle counterclockwise speeds closing. Any needle valve adjustments should be slight, not more than 1/4 turn at a time until the desired rate of shut off is achieved.



## Stop, Strainer and Check Valve

- S60-003 — Brass Valve Only
- S60-003A — Plated Valve Only
- S60-003S — Brass Valve with Tailpieces, Nuts and Washers
- S60-003AS — Plated Valve with Tailpieces, Nuts and Washers

Above include S21-014 Celcon plastic stop assembly.

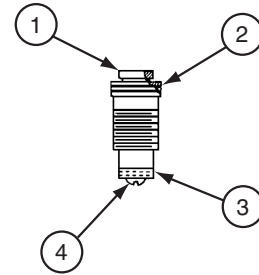

**Parts List** Stop Assembly S21-014  
Standard Celcon Core

Item	Part No.	Qty	Description
1	119-057	1	Valve Core
*2	125-001AW	1	"O" Ring
*3	125-001L	1	Bibb Washer
4	160-164	1	Screw

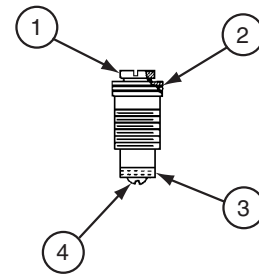

**Parts List** Stop Assembly S21-026  
Optional Brass Core

Item	Part No.	Qty	Description
1	119-038	1	Valve Core
*2	125-001AW	1	"O" Ring
*3	125-001L	1	Bibb Washer
4	160-146	1	Screw

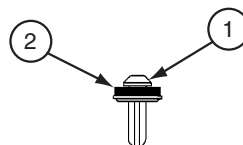

**Parts List** Check Assembly S21-015\*

Item	Part No.	Qty	Description
1	119-091	1	Plunger
2	125-001BB	1	Washer

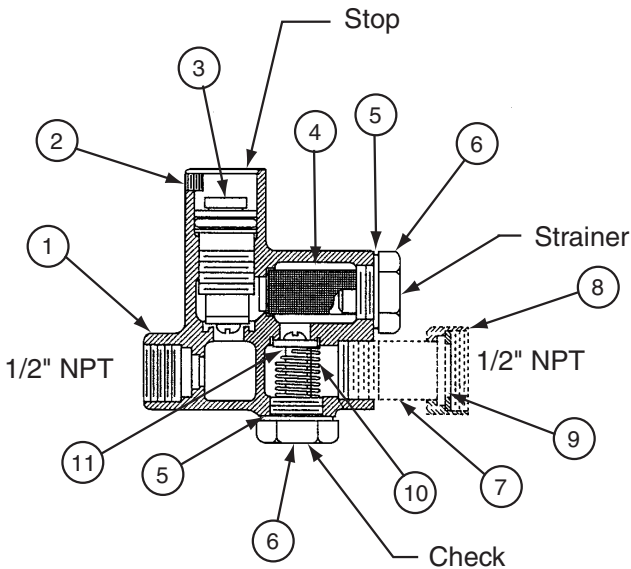

**Parts List** S60-003 Stop, Strainer and Check Valve

Item	Part No.	Qty	Description
1	118-039	1	Valve Body - Brass
1	118-039A	1	Valve Body - Plated
2	160-131	1	Set Screw
3	S21-014	1	Stop Assembly - Celcon
3	S21-026	1	Stop Assembly - Brass
*4	156-006	1	Strainer
*5	124-001BV	2	Fiber Washer
*6	153-068	2	Plug - Brass
7	129-007	1	Tail Piece - Brass
7	129-007A	1	Tail Piece - Plated
8	110-005	1	Tail Piece Nut - Brass
8	110-005A	1	Tail Piece Nut - Plated
*9	124-001AF	1	Tail Piece Washer
*10	135-001AB	1	Spring
*11	S21-015	1	Check Assembly

\* S45-050 Repair Kit Includes these parts



## Adjusting the Vernatherm Thermostatic Mixing Valve (August, 2004 to Present)



**NOTE:** This valve is **NOT** factory preset. Upon installation, the temperature of this valve must be checked and adjusted to ensure delivery of a safe water temperature. **Water in excess of 110°F (43°C) may cause scalding.**

1. Check the temperature when approximately 1.0 GPM water flow is reached and adjust if necessary (the range of the valve is 95°F–115°F (35°C–43°C). To adjust the temperature, follow the procedure below:
  - Loosen temperature locking nut with wrench.
  - Using a blade screwdriver, turn the adjustment stem **counterclockwise** to **increase** the temperature or **clockwise** to **decrease** the temperature.
  - Once desired temperature has been reached, tighten lock nut to prevent change in temperature.
2. Shut the hot water inlet off by closing the hot water stop-strainer-check valve. While the hot water supply is turned off, check to make sure the cold water flow is reduced. If the cold water is reduced properly, reopen the hot water supply.
3. Shut the cold water inlet off by closing the cold water stop-strainer-check valve. While the cold water supply is off, check to make sure that the hot water flow has shut down.

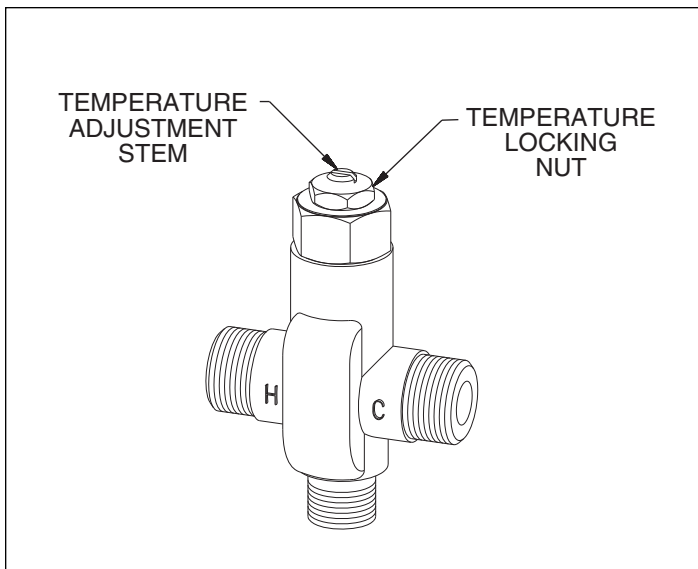



## Thermostatic Mixing Valve Maintenance and Troubleshooting (August, 2004 to Present)

*NOTE: Before attempting to troubleshoot the valve or disassemble the components, check for the following conditions:*

- *If stop/check valves are used, make sure that they are fully open*
- *Make sure that the hot and cold inlet pipes are connected properly, and that there are no cross-connections or leaking stop/check valves*
- *check the hot water heater output to make sure that it is at least 20° F above the set temperature.*

*Be sure to close the appropriate shut-off valves prior to disassembly of the valve and reopen the valves after inspection and repair is complete.*

### **Problem: Limited water flow**

*Cause: Dirt and debris have built up in the valve.*

Solution: Check the valve's piston for free and smooth movement, follow the procedures outlined below:

1. Remove the valve's cap and thermostat (see Figure on next page).
2. Push down on the piston with your finger (the piston should move freely). If the movement is not as it should be, the piston needs to be cleaned. Follow the method outlined below for cleaning the piston and valve body:
  - Remove the thermostat.
  - Lift the piston out with a needle-nose pliers and remove the spring.
  - Any cleaner suitable for brass and stainless steel may be used (if cleaning with suitable cleaner is not sufficient to remove debris, a 400-grit sandpaper may be used to polish and hone the piston and valve body).
  - Snap spring into piston (will detent) and reassemble into the valve body.
  - Retest the piston.
3. If, after a thorough cleaning, the piston does not move freely, the piston must be replaced. Contact your Bradley representative and ask for Repair Kit (part number S65-259).

### **Problem: External leaks in the system**

*Cause: O-rings have been damaged.*

Solution: Replace O-rings where necessary. For replacement of the O-rings, contact your Bradley representative and ask for Repair Kit (part number S65-259).

### **Problem: Improper water temperature or temperature fluctuation**

*Cause: Thermostat is slowly failing or not working at all.*

Solution: "Check the thermostat for proper operation".

1. At room temperature (80° F or less) remove cap and thermostat.
2. Place thermostat into container with 115° F water. The pushrod should pop out of the thermostat approximately 1/10".
3. If thermostat pushrod does not pop out, the thermostat must be replaced. Contact your Bradley representative and ask for Repair Kit (part number S65-259).

*Cause: Valve temperature is not properly set.*

Solution: "Adjust the temperature" per steps on previous page.



## Vernatherm Thermostatic Mixing Valve (S01-525) Parts List — Repair Kit S65-259 (August, 2004 to Present)

### Parts List S65-259 Valve Repair Kit

Item	Part No.	Qty	Description
5	S39-413	1	Thermostat
7	125-001BX	1	O-Ring
8	125-157	1	O-Ring

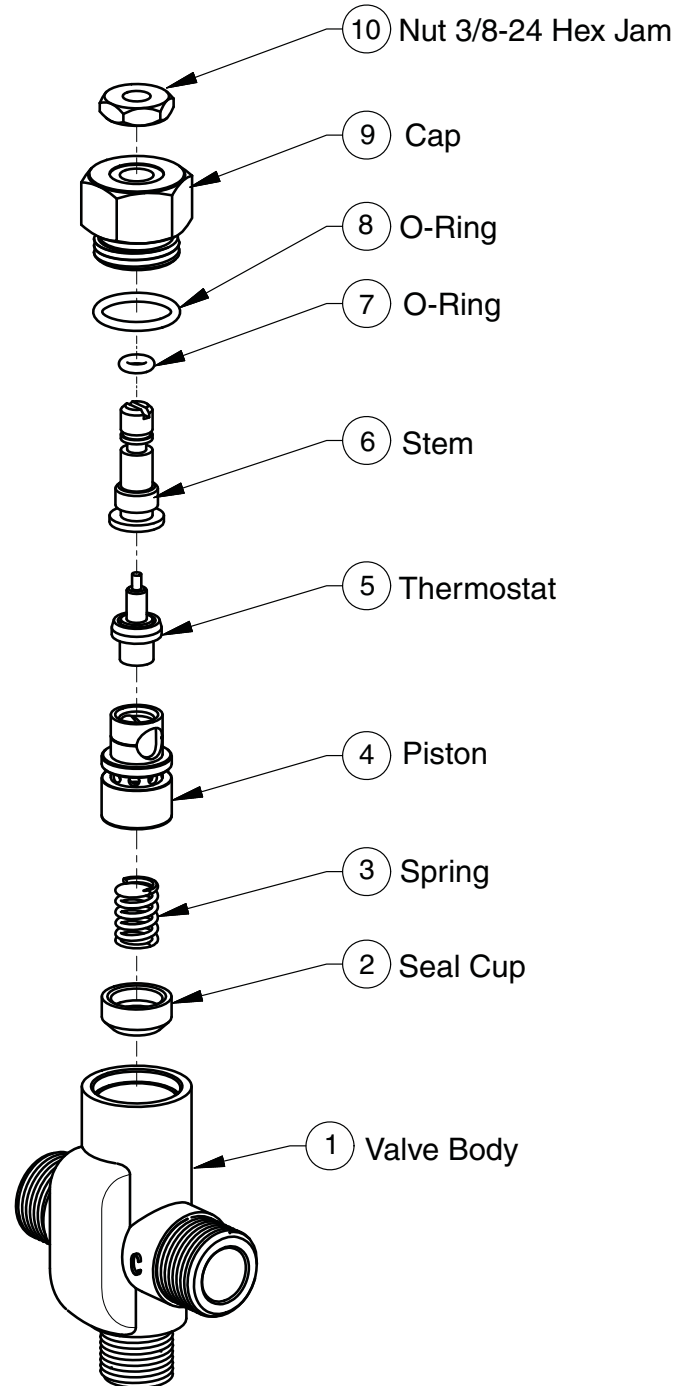



# Mixing Valve — Vernatherm™ — Thermostatic (Prior to Aug, 2004)

\*Repair kit S45-049 is pre-packaged and includes O-Ring, Flip Ring, Power Element and Spring.

## Maintenance Instructions

1. Disassemble the Vernatherm™ Valve as shown, being careful not to damage the power element. Replace the element, if necessary.
2. If necessary, remove the old flip ring and replace with a new ring.

*NOTE: An old or worn flip ring may cause temperature fluctuation and/or water chatter.*

3. Reassemble the power element and valve body. Apply grease to the main valve slide and gently ease into position, rotating so that grease is applied to the flip ring. Do not force the slide as this may push the flip ring from its position. To test, rotate the slide; a slight drag should be felt when correctly installed.
4. Reassemble the valve.

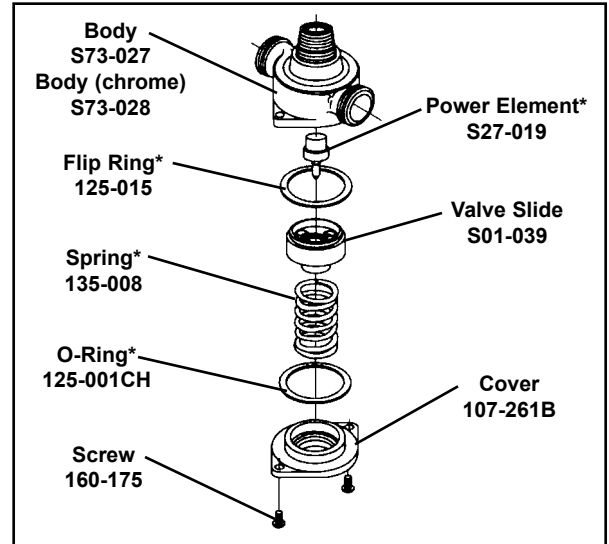

## Service Suggestions

When servicing the Vernatherm™ valve, make sure it is installed in the correct position. The most common error that occurs is when the valve is installed in the reversed position, that is, the hot line is connected to the cold line and the cold is connected to the hot.

*NOTE: A red ring is painted on the hot side of the valve.*

The table below lists conditions that occur when the valve is installed correctly, and when it is in the reversed position.

IF			THEN
Valve Position is	Hot Supply	Cold Supply	Valve Delivers
Correct	Hot	Cold	Mixed 107°
Correct	Hot	No Water	Valve shuts off or drips
Correct	No Water	Cold	Valve shuts off or drips
Correct	Hot	Hot	Hot
Correct	Cold	Cold	Cold
Reversed	Hot	Cold	Cold/below 107° Hot/above 107°
Reversed	Hot	No Water	Hot
Reversed	No Water	Cold	Cold
Reversed	Hot	Hot	Hot
Reversed	Cold	Cold	Cold





## Mixing Valve — Manual — S01-038

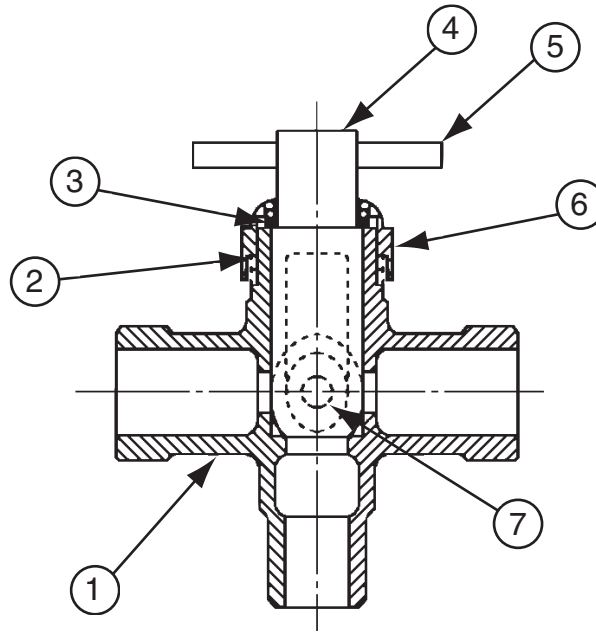

1/2 — 14 NPT male

### Manual Mixing Valve Parts List

Item	Part No.	Description	Valve Assembly S01-038	Valve Assembly S01-038S	Valve Assembly S01-038A	Valve Assembly S01-038AS	Repair Kit S45-197
			Qty				
1	118-034	Mixing Valve Body - Brass	1	1	—	—	—
1	118-034A	Mixing Valve Body - Chrome	—	—	1	1	—
2	124-001BD	Fiber Washer	1	1	1	1	1
3	125-001BC	O-Ring	1	1	1	1	1
4	119-059	Mixing Valve Core	1	1	1	1	1
5	152-038	Roll Pin	1	1	1	1	1
6	121-016	Bonnet - Brass	1	1	—	—	1
6	121-016A	Bonnet - Chrome	—	—	1	1	—
7	160-197	Screw - Brass	1	1	—	—	—
7	160-189	Screw - Stainless Steel	—	—	1	1	—
*	129-007	Tailpiece - Brass	—	2	—	—	—
*	110-005	Tailpiece Nut - Brass	—	2	—	—	—
*	129-007A	Tailpiece - Chrome	—	—	—	2	—
*	110-005A	Tailpiece Nut - Chrome	—	—	—	2	—
*	124-001AF	Tailpiece Washer	—	2	—	2	2

\* Parts not shown



### Volume Control Valve Repair Parts — S02-045

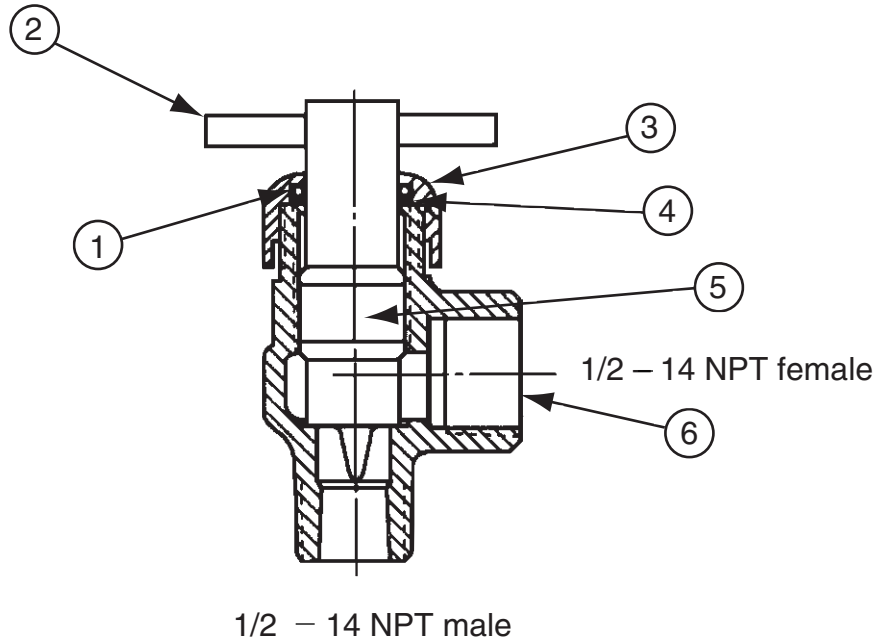

### Volume Control Valve Parts List

Item	Part No.	Description	Brass Valve S02-045	Chrome Valve S02-045A	Repair Kit S45-198
			Qty		
1	125-001BC	O-Ring	1	1	1
2	152-038	Roll Pin	1	1	1
3	121-016	Bonnet	1	—	1
3	121-016A	Bonnet	—	1	—
4	124-001BD	Fiber Washer	1	1	1
5	119-060	Valve Core	1	1	1
6	118-033	Valve Body	1	—	—
6	118-033B	Valve Body	—	1	—



## Sprayheads — Standard w/Neoprene Spray Ring Grommet

**NOTE:** Repair kit does not include sprayhead grommet. Order as a separate item.

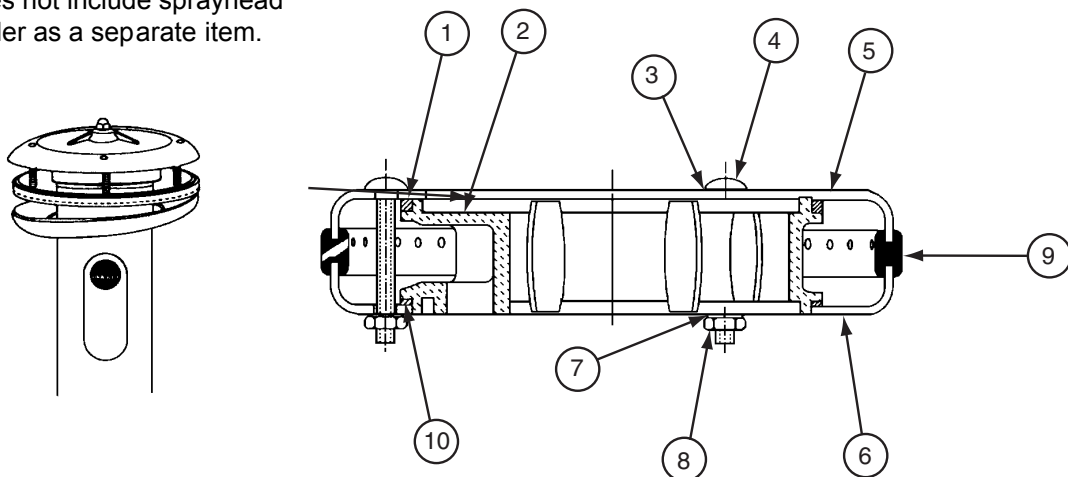

### Parts List

Item	Part No.	Description	Sprayhead Assembly	Repair Kit S45-051
			Qty	
1	125-001DE	Neoprene Washer-Top	1	1
2	139-031	Sprayhead Manifold	1	—
3	124-001AL	Washer	3	4
4	160-211	Carriage Bolt	3	4
5	115-061	Sprayhead Top	1	—
6	116-008	Sprayhead Bottom	1	—
7	124-001AT	Washer	3	4
8	161-025	Nut	3	4
9	124-020C	Sprayhead Grommet - Circle	1	—
9	124-020D	Sprayhead Grommet - Semi-circle	1	—
9	124-020E	Sprayhead Grommet - Corner	1	—
10	125-001DF	Neoprene Washer-Bottom	1	1

### Sprayhead Service Suggestions

**Problem: Water splashes over the rim of the bowl.**

*Cause:* Foreign matter has reduced the size of the sprayhead slots, causing greater pressure at the open slots.

**Solution:** Clean the sprayhead:

1. Disassemble the sprayhead and dislodge any dirt, lime build-up and foreign debris with a wire brush.
2. Sprayheads with rubber grommet spray rings may be cleaned by rubbing a coin over the grommet.
3. Throttle down the volume control (water spray should strike the bowl without splashing outside of the bowl).

**Problem: Water flow diminishes from the sprayhead.**

*Cause:* Strainer portion of the stop-strainer-check valve is plugged.

**Solution:** Remove and clean the strainer screen from the stop-strainer-check valve.

*NOTE:* The sprayhead shown above includes a perforated neoprene spray ring grommet that is self-cleaning. The water pressure flexes the spray holes which slows accumulation of foreign matter and tends to “break loose” any such deposits that may have accumulated.



## Sprayhead Tubing Connections

*NOTE: Flush supply lines before making connections.*

Follow the procedures below and refer to Figures below when installing tubing to ensure that you achieve a leakproof seal.

- Using a sharp razor, cut tubing squarely and remove any burrs. **DO NOT** pinch or crush end of tubing.
- Loosen nut on fitting. Moisten end of tube and push into fitting until it is firmly seated. Tighten nut to secure tube to fitting (make sure nut is securely tightened).
- If connector leaks, reseal tubing according to above procedure. If leaking persists, replace male connector, or call your Bradley representative for assistance.

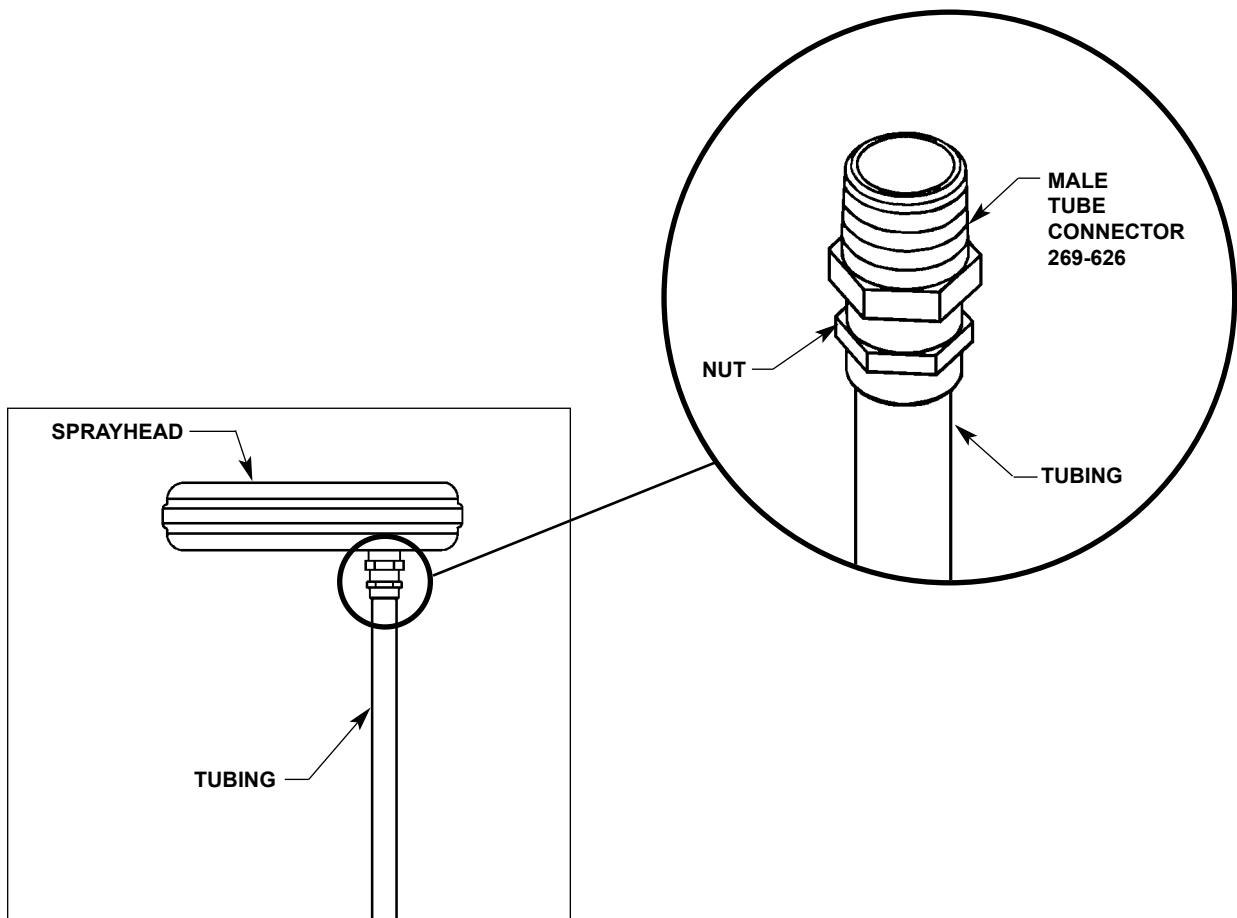



## Soap Valve — Liquid — S09-007S

### Parts List

Item	Part No.	Description	Attaching Parts S09-007S	
			Qty	
1	118-025	Valve Body	1	
2	110-007	Packing Nut	1	
3	135-001L	Spring	1	
4	125-001BU	Washer	1	
5	119-028	Plunger	1	
*	161-014	Nut	1	
*	124-001D	Washer	2	
*	142-002AH	Washer - Stainless Steel	1	

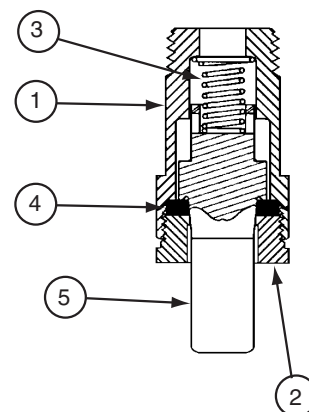

\* Not Illustrated

This valve delivers a measured amount of soap with each upward stroke. The soap dispenser has been standard on washfountains since 1983 and is not well-suited for very thick lotion soaps.

*NOTE: Lotion soap will clog liquid soap valves. Use only lotion soap valves with lotion soap.*

## Soap Valve — Lotion — S09-057S

### Parts List

Item	Part No.	Description	Valve Assembly S09-057	Attaching Parts S09-057S
			Qty	
1	124-001D	Washer	—	1
2	110-057	Nut	—	1
3	125-001AN	Stopper	—	1
4	159-114	Reinforcing Plate	—	1
5	124-001AT	Washer	—	1
6	160-176	Screw	—	1
7	S09-040	Valve	1	1
8	S53-045	Adaptor	1	1

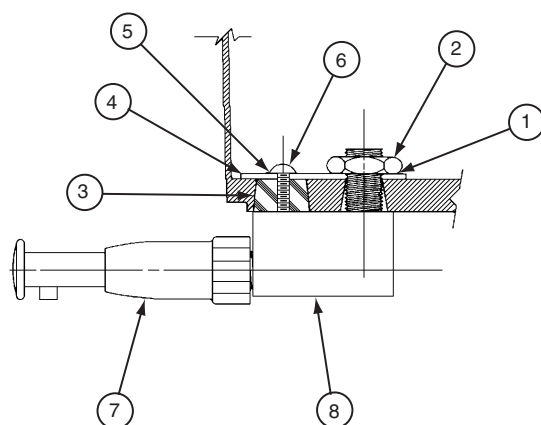



## Soap Valve — Powdered — S09-010A

### Parts List

Item	Part No.	Qty	Description
1	160-069	1	Screw, 1/4-20 RD
2	142-002X	1	Washer, 1/4 Split-Lock
3	S62-002	1	Agitator / Slide Assy.
4	192-004	1	Lever - Powdered Soap

*NOTE: Reducer plugs are available for use with fine granulated soap to reduce the flow.*

*NOTE: Valves can be changed from powdered to liquid by plugging the innermost, or “bearing” hole with rubber plug, part number 125-001AK. To change from liquid to powdered, the plug must be removed. If none is present, it will be necessary to drill out the bearing hole with a 1/2" or 5/8" drill. The plastic container configuration forms a natural template for locating the bearing hole.*

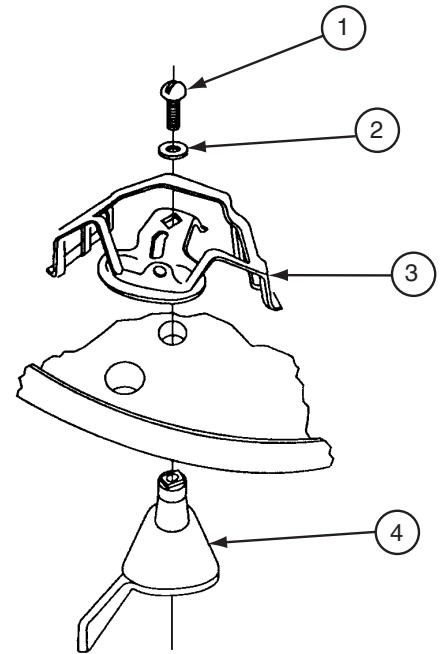



## Soap Maintenance Tips

### SOAP RECOMMENDATIONS

Quality soap dispensers require good quality soap and periodic maintenance to properly operate. Bradley soap dispensers will provide dependable, consistent operation over the long term when soap with reasonable viscosity and pH levels are used and when a minimal amount of periodic maintenance is performed on the valves.

Soap thickness is determined by a measurement called viscosity. Soap viscosity should be between 100 cps (centerpoise) and 2500 cps for all Bradley soap dispensers. Thinner soaps are perceived by the users as being "watered down" so users tend to take more than they need, resulting in waste. Thick soaps flow slower and inhibit the "flushing" action of the valves, which allows the soap to congeal in the valve and cause clogs.

The pH (acid) level of the soap should be in the range of 6.5 to 8.5. More acidic soaps (pH levels lower than 6.5) will corrode metal parts (even stainless steel!!) and degrade rubber and plastic components. They will also cause skin irritation. Most inexpensive soaps (typically the pink lotion type) fall into this acidic category and will eventually cause valve failure and metal corrosion. Base soaps (pH levels higher than 8.5) will cause swelling or degradation of rubber and plastic parts and skin irritation.

Generally, any quality soap meeting the viscosity and pH guidelines above will work well with Bradley soap dispensers. PCMX or Isopropanol based antibacterial soaps (within viscosity and pH limits) will also work with Bradley dispensers. Soaps satisfying these basic guidelines will provide consistent flow and reduce clogs.

Most soap dispenser problems are caused by soap that is too thick or corrosive, or by a lack of maintenance. Many soaps come in concentrate form which must be diluted with water. Often, the soap is improperly diluted or used straight out of the bottle, which causes clogging and valve failure. If proper soap is being used, valves that have never been cleaned are usually the source of dispensing problems. Bradley has entered into an agreement with Champion Brand Products to provide additional customer service for purchasers of our dispensers regarding soap issues. They are very helpful and can get to the bottom of almost any soap dispenser related problem. They also sell an excellent "Bradley approved" soap. Please see **Soap Instruction Sheet 215-1286** for details about soap valve cleaning or how to contact Champion. With proper maintenance and soap, Bradley dispensers will provide long term, trouble free operation.

### SOAP DISPENSER MAINTENANCE INSTRUCTIONS

Bradley soap dispensers will provide dependable, consistent operation over the long term when the proper soap is used and when a minimal amount of periodic maintenance is performed on the valves. Valves must be maintained (cleaned) to function properly.

To ensure proper operation of your soap dispenser, follow these instructions:

- Once per month, unscrew valve from reservoir and soak it for 30 minutes in hot water.
- Push valve at least 20 times while it is soaking.
- Flush soap reservoir with hot water while valve is soaking.

In cases of extreme clogging, the valve should be disassembled and the parts should be soaked in hot water or cleaning solution to restore proper functioning. Soap dispensers that will not be used for extended periods of time (schools during summer break, etc.) should be drained, cleaned and left empty until put back into service. Soap left on the outside of dispensers can cause discoloration and corrosion of the reservoir (even on stainless steel units). All soap should be wiped or scrubbed off daily, then the outside of the dispenser should be rinsed with clear water and dried with a soft cloth.



# Infrared Module — AccuZone® (Terrazzo and Stainless Steel Bowls; Bradstone Bowls Prior to September 2003)

## S83-043 Infrared Module — Circular

Item	Part No.	Description	Qty
1	S51-003	Shell Assembly	1
2	S83-041	PC Mounting Board	1
3	160-197	Screw 10-32 x 3/8" Lg.	12
4	247-001	Insulator	3
5	142-002AV	Washer	12
6	140-718	Sensor Bracket	6
7	S83-039	IR Sensor Classic WFT	6
8	269-832	IR Curved Lens	6
9	S04-112	Module Cover Assy.	1
*	124-067	Cover Gasket	1

**NOTE:** Item 4 - 247-001 Insulators go between circuit board and metal mounting tabs.

\* Not shown on diagram

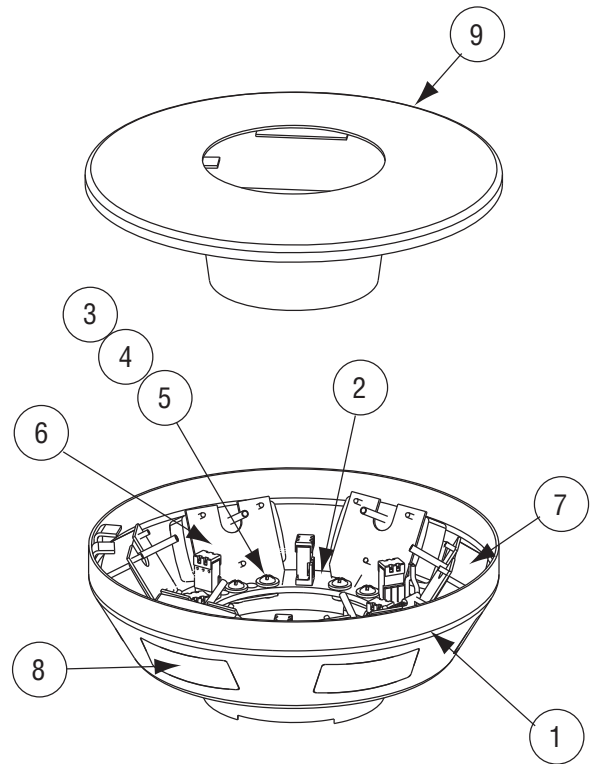

## S83-040 Infrared Module — Semi-Circular

Item	Part No.	Description	Qty
1	S51-002	Shell Assembly	1
2	S83-038	PC Mounting Board	1
3	160-197	Screw 10-32 x 3/8" Lg.	8
4	247-001	Insulator	3
5	142-002AV	Washer	8
6	140-718	Sensor Bracket	3
7	S83-039	IR Sensor Classic WFT	3
8	269-832	IR Curved Lens	3
9	S04-112	Cover Assembly	1
*	124-067	Cover Gasket	1

**NOTE:** Item 4 - 247-001 Insulators go between circuit board and metal mounting tabs.

\* Not shown on diagram

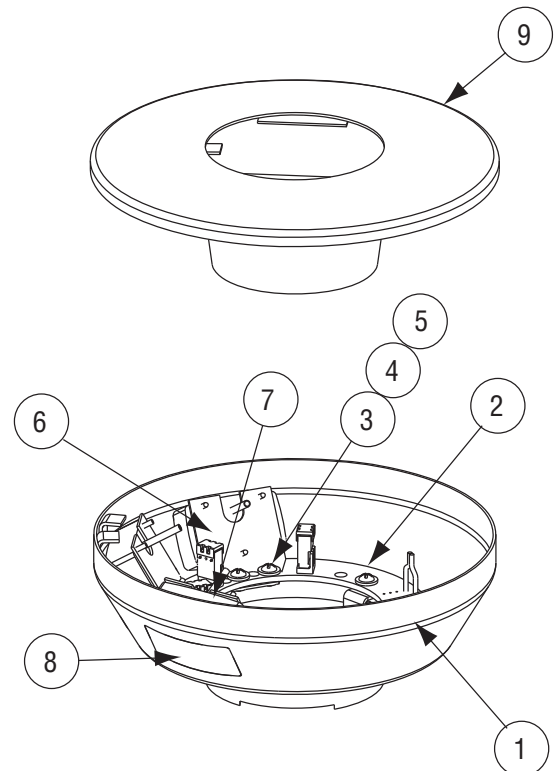





# Infrared AccuZone Valve Assembly — Circular & Semi (Terrazzo and Stainless Steel Bowls; Bradstone Bowls Prior to September 2003)

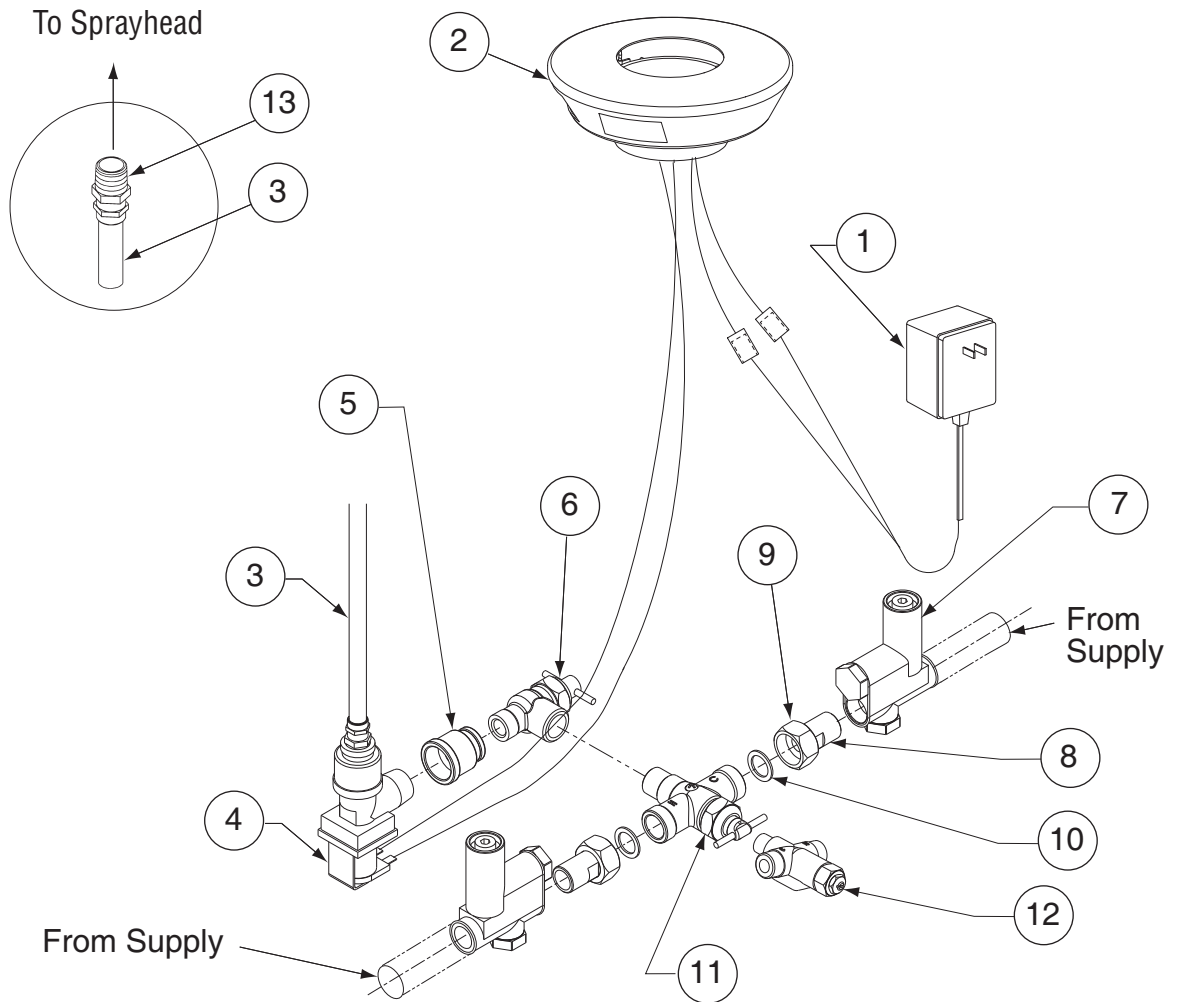

## Parts List

Item	Part No.	Description	Qty
1	S83-134	24 VAC Transformer (with Female Connectors)	1
2	S83-043	Infrared Module — Circular (See previous Page)	1
2	S83-040	Infrared Module — Semi-circular (See previous page)	1
3	R68-600012	1/2" Tubing to Sprayhead	1
4	S08-055	Solenoid Assy.	2
5	269-851	Reducer	1
6	S02-045	Volume Control Valve	1
7	S60-003	Stop-Strainer-Check Valve	2
8	129-007	Tailpiece	2
9	110-005	Tailpiece Nut	2
10	124-001AF	Tailpiece Washer	2
11	S01-038	Manual Mixing Valve	1
12	S01-525	TMA (Optional)	1
13	269-626	3/8" NPT x 1/2" Tube Conector	1

## Troubleshooting AccuZone Infrared

1. **Check the lens** — (windows) of the sensor(s) to make sure they are not pushed in, covered with debris or scratched. Scratches can distort the view of the sensor. Clean if dirty or replace if damaged. If lens needs to be replaced use Lord acrylic adhesive 406/19 or an epoxy glue to glue the lens in place and seal from outside moisture. Clean off excess glue and allow to dry.
2. **Verify there is power** — to the transformer and verify there are 24 volts coming from the transformer.
3. **Unplug the transformer** — harness from the module harness, disconnect module harness from the solenoid valve. **Plug the transformer directly to the solenoid valve.** If there is 24 volts, and the solenoid is working properly, water will turn on and run continuously. If the water does not turn on and you know there are 24 volts coming from the transformer, the solenoid will have to be replaced.
4. **If the water does not turn off or dribbles** — after disconnecting the power, there is debris at the diaphragm of the solenoid valve. Take apart the solenoid valve to check for debris which may be keeping the valve open. Unscrew the 3 or 4 screws that hold the solenoid to the lower valve body. (*The S27-250 solenoid valve does have a screen in the inlet end. Check and make sure that screen is clean.*) Clean the diaphragm and make sure the small hole in the diaphragm is not plugged. This small hole is very hard to see. Hold it up to the light to find the hole. It is located about half way between the OD and the ID. Soak the diaphragm in vinegar for 15 to 20 minutes and rinse well with water to remove mineral deposits. Reassemble valve and test again with power from the transformer.
5. **If the solenoid is working,** — take the cover off the module and check to make sure all leads are connected properly and all sensors are plugged onto the circuit board.

6. **Make sure the output and input wires** — from the circuit board are not loose or broken off.

7. **Check the MOV (metal oxide Varistor)** — on the circuit board for discoloration. This varistor can be burned out from power surges and lightning strikes. The discoloration will be evident if the varistor is burned out. If the varistor is burned out, the circuit board will have to be replaced. **Note: Do not use the part number printed on the circuit board, that is a bare board.**

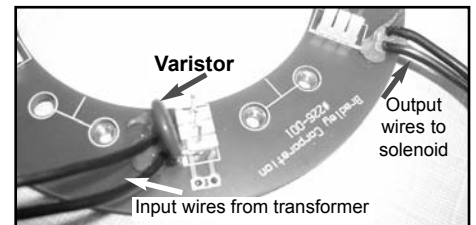

8. **Unplug all sensors** — from the circuit board (remembering where the wires go). Plug in one sensor at a time. If sensor works properly, continue on to the next sensor. Test all sensors individually. If some sensors work and some do not, plug the sensors not working into the location where the sensors do work. This will confirm that the sensor is dead or there is a problem in the circuit board. It is possible that an on site electrical surge or a lightning strike could burn out a sensor, all sensors or an individual circuit on the circuit board. If you find any in this condition, add a good surge protection device to the circuit to avoid future problems. **Note: Make sure your sensor has the foam strip properly applied to the center of the sensor.**

9. **If an individual station is not working,** — loosen the screws on the sensor bracket and reposition to make sure the sensor is properly positioned in front of the lens (window). The sensor should not be seeing any edges of the module opening.

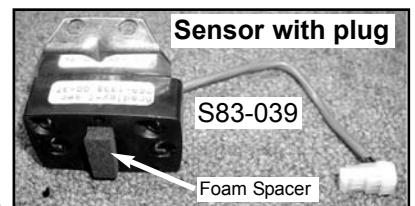

Sensor assembly includes the disconnect terminal and foam spacer on face of sensor. The bracket is not included as shown.

10. **Replace sensors as necessary.** — Order assembly # S83-039.

11. **If a new installation,** — and the above checks do not resolve the problem, check the wiring of the sensor plugs.

If you need further assistance, please call your local Bradley Representative. Please call us at 1-800-Bradley if you need the name and telephone number of your local Bradley Representative.



# Infrared Module — Adaptive Circular & Semi (Terreon® Bowls; Bradstone Bowls from September 2003 to Present)

## Parts List — Infrared Circular Module S50-344

Item	Part No.	Description	Qty
1	219-035A	Circular Shell	1
2	269-1351	Sensor Window	6
3	P10-569	Velcro Strip	6
4	269-1878	Adaptive Sensor	6
5	269-1219	Clip	12
6	S04-112	Module Cover	1
*15	S53-261	Wire, Red, 4", Female Leads	4
**16	S53-271	Wire, Black, 4", Female Leads	5
*17	S53-261A	Wire, Red, 48", Female Leads	2
*18	S53-272	Wire, Black, 48"	1
**19	269-599	Cable Tie	6
**	124-067	Cover Gasket	1

\* Illustrated on next page.

\*\* Not shown.

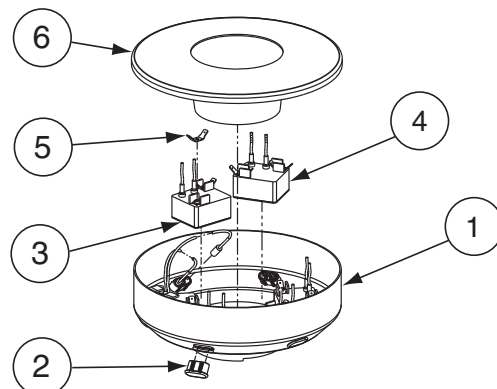

Sensor Eyes (part of sensor - Item 4) to be inserted in window adjacent to sensor.

Windows (Item 2) snap fit into module shell (Item 1). Put a small amount of RTV sealant between window lip and module shell to seal out contaminants.

## Parts List — Infrared Semi-Circular Module S50-367

Item	Part No.	Description	Qty
1	219-033A	Circular Shell	1
2	269-1351	Sensor Window	3
3	P10-569	Velcro Strip	3
4	269-1878	Adaptive Sensor	3
5	269-1219	Clip	6
6	S04-112	Module Cover	1
**15	S53-261	Wire, Red, 4", Female Leads	2
**16	S53-271	Wire, Black, 4", Female Leads	2
*17	S53-261A	Wire, Red, 48", Female Leads	1
*18	S53-272	Wire, Black, 48"	1
**19	269-599	Cable Tie	3
**	124-067	Cover Gasket	1

\* Illustrated two pages after this one.

\*\* Not shown.

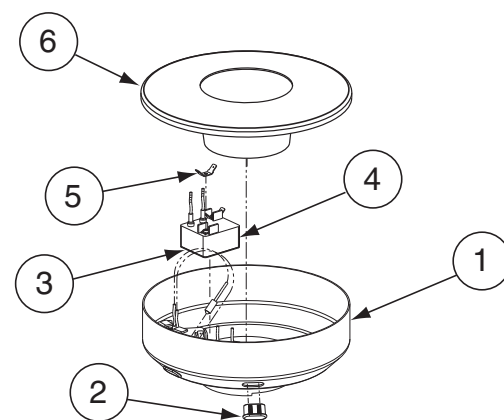

Sensor Eyes (part of sensor - Item 4) to be inserted in window adjacent to sensor.

Windows (Item 2) snap fit into module shell (Item 1). Put a small amount of RTV sealant between window lip and module shell to seal out contaminants.



# Infrared Adaptive Valve Assembly — Circular (Terreon Bowls; Bradstone Bowls from September 2003 to Present)

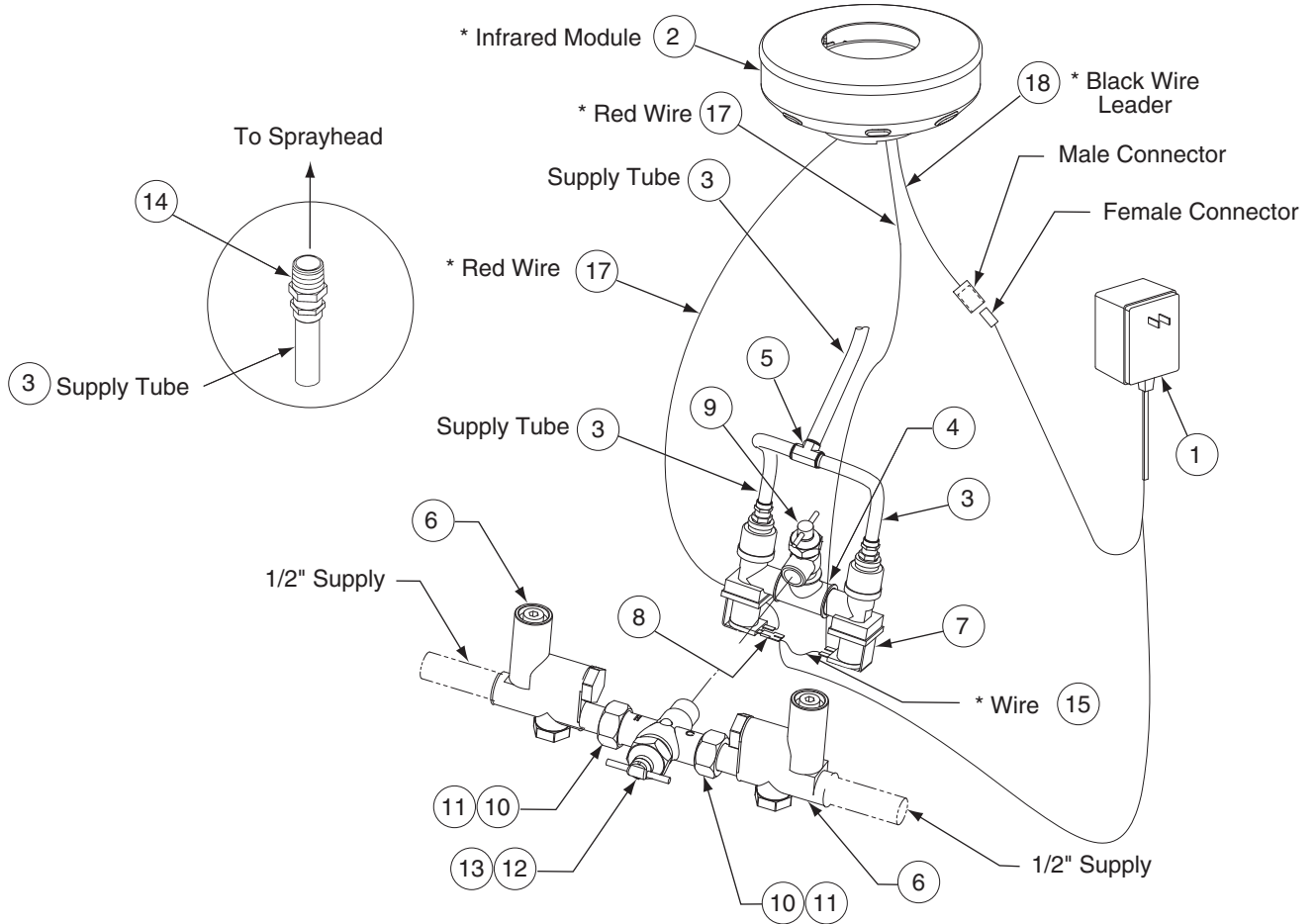

## Parts List

Item	Part No.	Description	Qty
1	S83-134	24 VAC Transformer	1
*2	S50-344	Infrared Module	1
3	R68-600012	1/2" Tubing to Sprayhead	1
4	269-1222	Tee	1
5	269-764	Tee Union	1
6	S60-003	Check Valve	2
7	S08-055	Solenoid Assy.	2
8	269-620	Adapter	1
9	S02-045	Volume Control Valve	1
10	110-005	Tailpiece Nut	2
11	124-001AF	Tailpiece Washer	2
12	S01-038	Manual Mixing Valve	1
13	S01-525	TMA (Optional) - Manual Mixing Valve Shown	1
14	269-626	3/8" NPT x 1/2" Tube Conector	1

\* Parts list on previous page.





## Troubleshooting Adaptive Infrared

There is a LED diagnostic light built into the small black box housing the circuitry for the sensor. Below is a list of what the signals from the LED mean. Use this list to troubleshoot the sensor.

1. LED not illuminated — no power is getting to the sensor. Check for power at the 110 VAC wall outlet and from the wires from the 24 VAC transformer. If there is 110 VAC power at the wall outlet, but no power from the transformer, touching the leads from the transformer while plugged in or a power surge may have burned out the transformer. Add surge protection at the outlet if a power surge is suspected and replace the transformer. If 24 VAC power is being supplied from the transformer, check for loose wires and proper connections (refer electrical wiring diagrams on previous two pages).
2. Fast Blink — Sensor is detecting something in its view and water should be on (power is being sent to the solenoid). If the sensor is blinking fast, the water is turning on and there is nothing in the detection area, disconnect the power for at least 30 seconds. This will allow the sensor to lose its memory and be reset. Reconnect the power and wait 2 full minutes to allow the sensor to relearn the environment before attempting to activate. The sensor may take up to 8 minutes to readjust if it activated during those 2 minutes. If the condition persists, make sure the LED's at the ends of the sensor cables are pushed all the way in to the backs of the lenses. If the sensor is blinking fast and the water is not turning on, go through the troubleshooting guide for the solenoid.
3. Slow Blink — Sensor is detecting something in its view and the water is off (power is not being sent to the solenoid). The sensor has detected a stationary object in its view for more than 30 seconds and shut off power to the solenoid valve. Remove the object, if it is still in the bowl, and repeat the part of Step 2 for resetting the sensor.
4. Blinking SOS (3 short, 3 long, 3 short) — The sensor has detected an overload condition and shut down to protect its circuits. Check connections against the wiring diagram. This condition usually means the solenoid valve is not properly wired. After correcting any wiring error, it will be necessary to restart the sensor by repeating the part of Step 2 for resetting the sensor.

If you need further assistance, please call your local Bradley Representative. Please call us at 1-800-Bradley if you need the name and telephone number of your local Bradley Representative.



## Touch Time™ Module — Circular & Semi

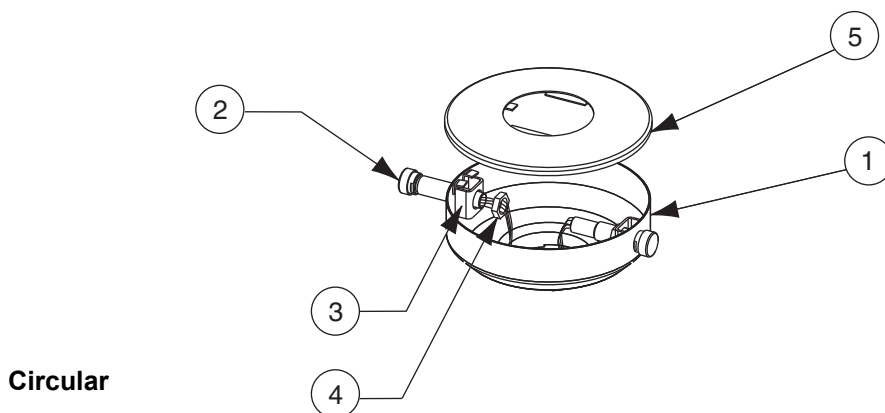

### Parts List — Touch Time Circular Module S83-179

Item	Part No.	Description	Qty
1	219-031A	Circular Shell	1
2	S83-139B	Touch Time Switch	2
3	140-802	Touch Time Bracket	2
4	110-115	1/2" - 14 NPSM Nut, Brass	2
5	S04-113	Module Cover Assembly	1
**	124-067	Cover Gasket	1

\*\* Not shown.

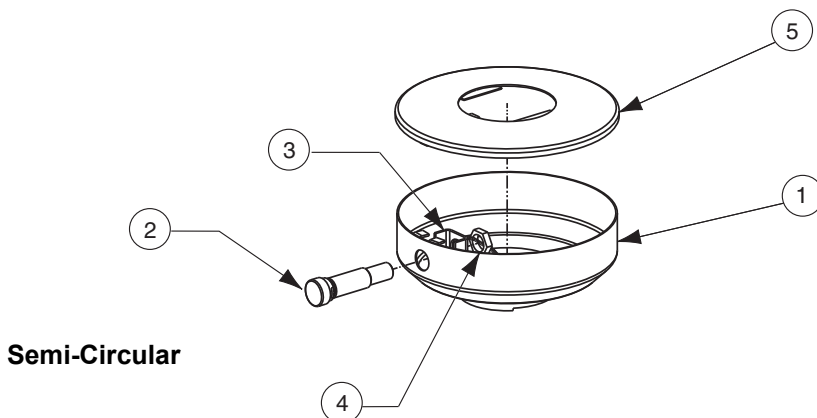

### Parts List — Touch Time Semi-Circular Module S83-180

Item	Part No.	Description	Qty
1	219-032A	Circular Shell	1
2	S83-139B	Touch Time Switch	1
3	140-802	Touch Time Bracket	1
4	110-115	1/2" - 14 NPSM Nut, Brass	1
5	S04-113	Module Cover Assembly	1
**	124-067	Cover Gasket	1

\*\* Not shown.



# Touch Time™ Valve Assembly — Circular & Semi

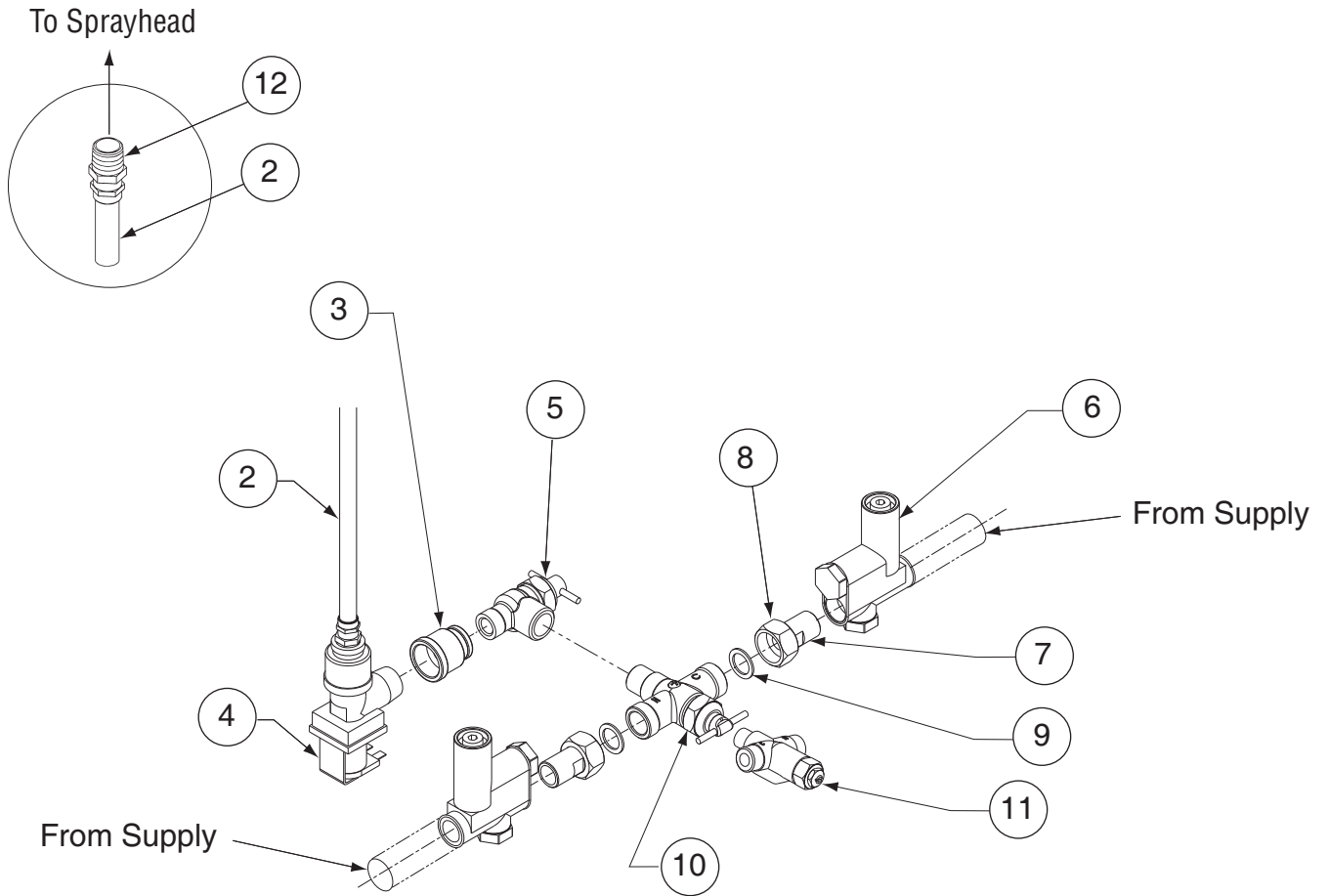

## Parts List

Item	Part No.	Description	Qty
*1	S83-134	24 VAC Transformer	1
2	R68-600012	1/2" Tubing to Sprayhead	1
3	269-851	Reducing Coupling, 1/2 NPT x 3/8 NPT	1
4	S08-055	Solenoid Assy.	2
5	S02-045	Volume Control Valve	1
6	S60-003	Check Valve	2
7	129-007	Tailpiece	2
8	110-005	Tailpiece Nut	2
9	124-001AF	Tailpiece Washer	2
10	S01-038	Manual Mixing Valve	1
11	S01-525	TMA (Optional)	1
12	269-626	3/8" NPT x 1/2" Tube Connector	1
*13	269-1364	Terminal Block	1
**	S83-142	Power Cord Assembly	1

\* Illustrated on next two pages.

\*\* Not Illustrated.





# Touch Time™ Wiring — Circular

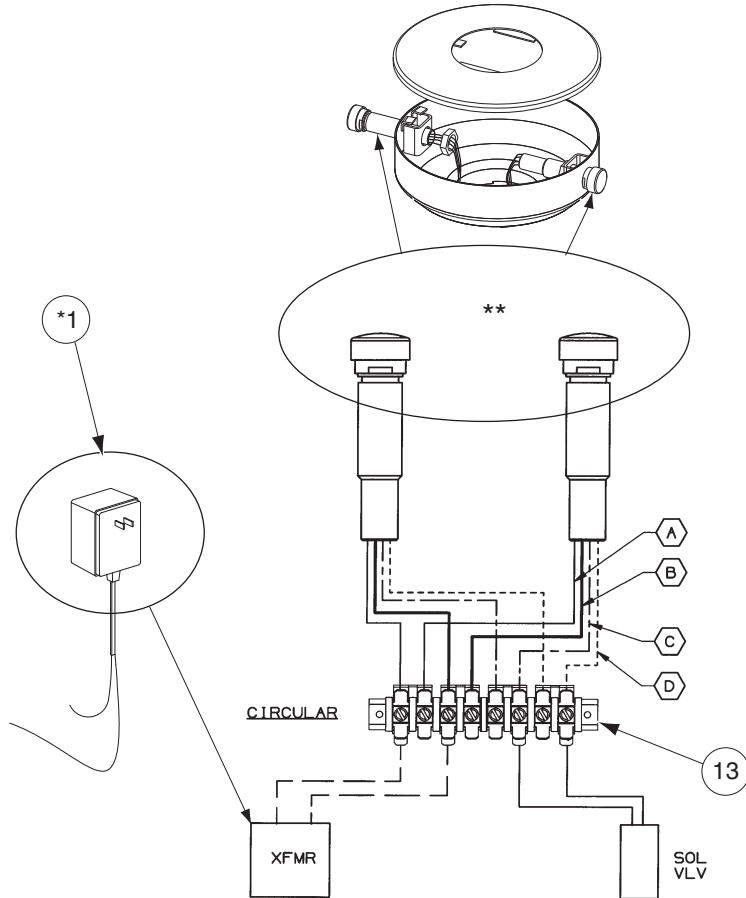

**\*\* Circular TT  
Module Assembly**

**WIRE SCHEDULE**

<b>A</b>	BLACK	——	(XFMR)
<b>B</b>	BROWN	——	(XFMR)
<b>C</b>	GREEN	- - - -	(SOL. VALVE)
<b>D</b>	GRAY	- - - - -	(SOL. VALVE)

- \* Parts list on previous page.
- \*\* Parts list — See two pages before this one.



# Touch Time™ Wiring — Semi-Circular

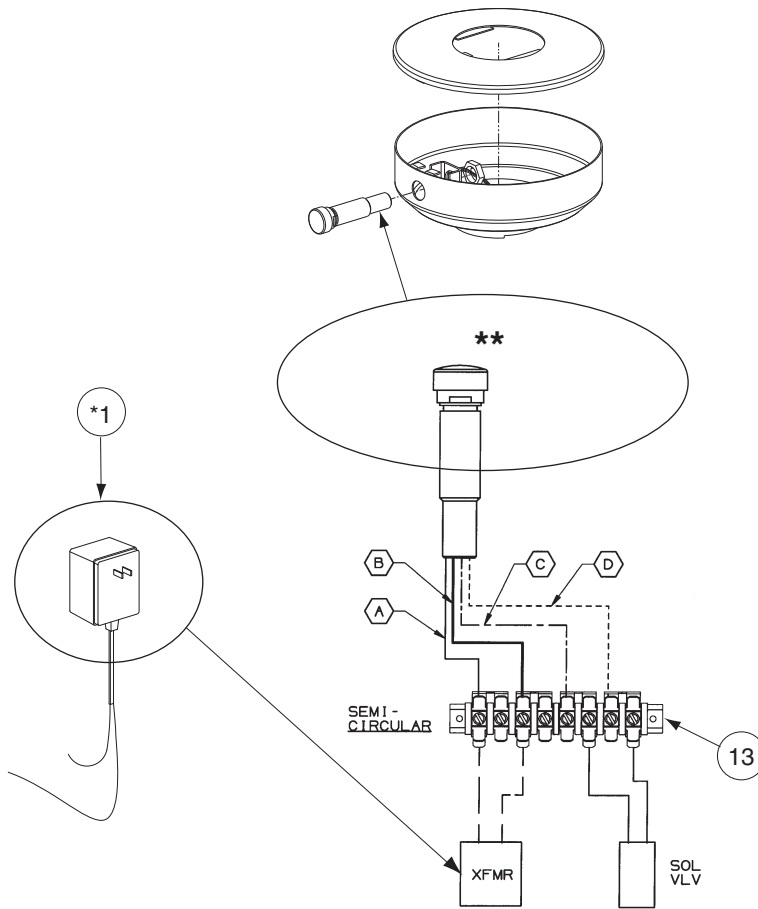

**\*\* Semi-Circular TT Module Assembly**

WIRE SCHEDULE

<b>A</b>	BLACK	——	(XFMR)
<b>B</b>	BROWN	——	(XFMR)
<b>C</b>	GREEN	- - - -	(SOL. VALVE)
<b>D</b>	GRAY	- - - -	(SOL. VALVE)

- \* Parts list — See two pages before this one.
- \*\* Parts list — See three pages before this one.



## Touch Time Troubleshooting



**IMPORTANT:** Make sure there is electrical power going to the transformer and there are 24 volt s coming from the transformer.



**CAUTION:** Be sure to turn off electrical and water supplies as instructed during troubleshooting.

### If the Touch Time™ push button unit does not function properly

1. Make sure the water supply and the 24 VAC power are both turned on.

If the water supply and the electrical power are both turned on but the push button is still not functioning, check the wiring following the steps outlined in procedure #2 below.

2. Check the wiring following the procedure outlined below:
  - a. Turn the electrical power off.
  - b. Check the wiring for loose connections or corrosion and correct if necessary .
  - c. Turn the electrical power back on and retest the push button.

If, after checking the wiring, the push button is still not functioning properly , test the transformer following the steps outlined in procedure #3.

3. Test the transformer with a volt meter following the procedure outlined below:
  - a. Turn the water supply off (the electrical power should remain on).
  - b. Set the volt meter scale to be able to read "24 V AC".
  - c. Connect the volt meter leads from the transformer as shown in the diagram.
  - d. The voltage reading should indicate 24 VAC  $\pm$  10%.

If you are unable to obtain a proper voltage reading, the transformer is not working properly and needs to be replaced. Contact your Bradley representative to order a replacement transformer.

If the transformer is working properly, turn the water supply back on and test the solenoid following the steps outlined in procedure #4.

4. Test the solenoid valve following the procedure outlined below:
  - a. Disconnect the Green/Gray wires from the solenoid.
  - b. Disconnect the brown transformer leads from the terminal block.
  - c. Connect the brown transformer leads directly to the solenoid. The solenoid coil should activate and you should hear a single click and a humming noise.
  - d. If the solenoid still does not function, turn off the electrical power. Then remove the four screws that secure the clamping plate to the valve body . Be careful not to lose the armature or spring
  - e. Remove the diaphragm and clean it gently but thoroughly . Hold the diaphragm up to a light and find the small hole which is located about halfway between the inner diameter and the outer diameter . Make sure the hole in the diaphragm is not plugged.
  - f. Reassemble the valve in reverse order and test again with power from the transformer .

If the solenoid coil does not activate, the solenoid valve is not working properly and needs to be replaced. Contact your Bradley representative to order a replacement solenoid valve assembly .

If, after checking the transformer, the solenoid valve and the wiring, you are unable to activate the spray-head by pressing the Touch Time push button, the Touch Time switch assembly is not working properly and needs to be replaced. Contact your Bradley representative to order a replacement switch assembly.



### Common Parts — S27-250 Solenoid

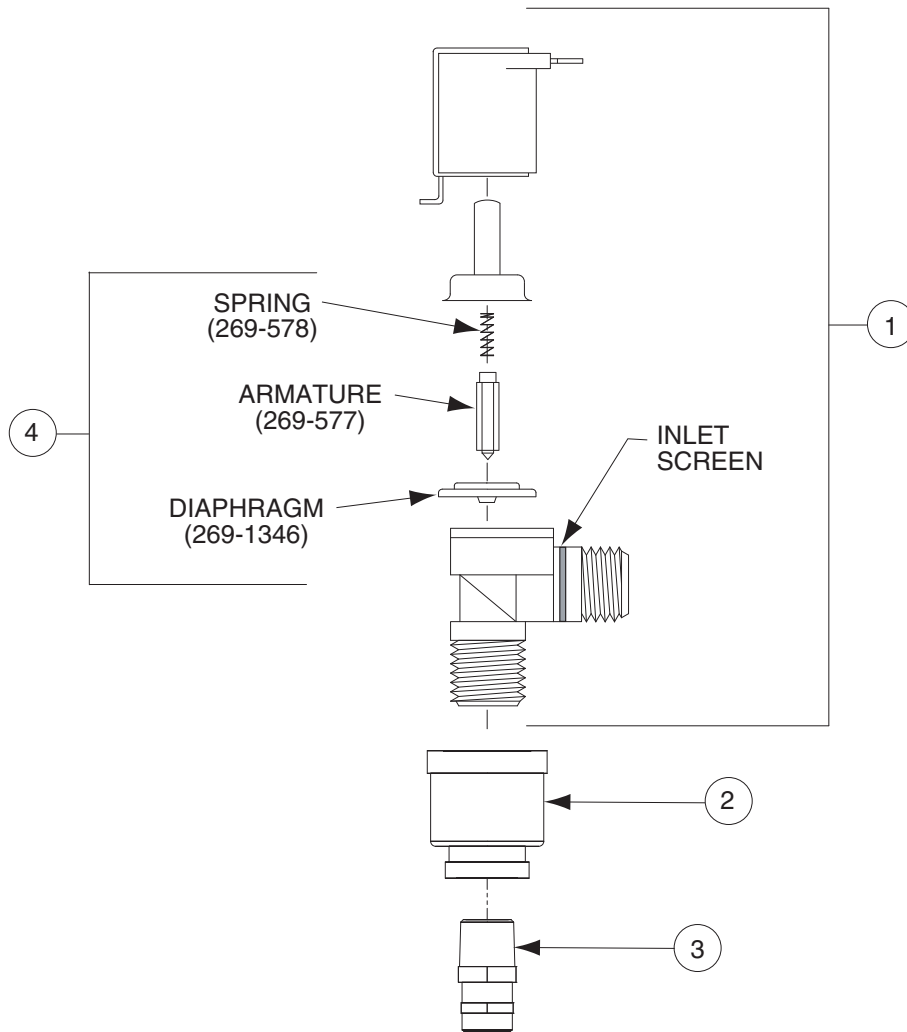

### S08-055 Solenoid Valve Assembly

Item	Part No.	Description	Qty
1	S27-250	Solenoid Valve	1
2	269-1246	3/4x 3/8 Reducing Coupling	1
3	269-626	Male Connector	1
4	S65-155	Solenoid Repair Kit	1



**Common Parts — Solenoid (Prior to March 2002; Semi-Circular Only)**

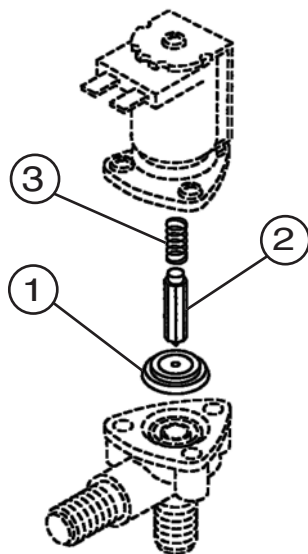

**269-719 Eaton Solenoid Valve Assembly**

Item	Part No.	Description	Repair Kit S65-113
			Qty
1	269-983	Diaphragm	1
2	269-577	Armature	1
3	269-578	Spring	1



## Solenoid Valve Troubleshooting



**IMPORTANT:** Make sure there is electrical power going to the transformer and there are 24 volts coming from the transformer.



**CAUTION:** Turn off electrical and water supplies to unit before troubleshooting.

**Problem:** Sprayhead drips or fails to shut off.

**Cause:** There is debris trapped between the diaphragm and the valve seat or a clogged inlet screen. Refer to solenoid parts breakdown two pages previous to this one.

**Solution:** Remove debris between diaphragm and the valve seat. Clean the inlet screen.

1. Remove the four screws that secure the clamping plate to the valve body. Be careful not to lose the armature or spring.
2. Remove the diaphragm and clean it gently but thoroughly. Hold the diaphragm up to a light and find the small hole which is located about halfway between the inner diameter and the outer diameter. Make sure the hole in the diaphragm is not plugged.
3. Reassemble the valve in reverse order and test with power from the transformer.

**Problem:** Sprayhead fails to turn on.

**Cause:** A failed coil for the valve or improper wiring connection.

**Solution:** Test the valves and check the wiring connections.

1. Disconnect the wires from the IR module to the transformer and solenoid (refer to wiring diagrams for connections).
2. Connect the wire from the transformer to the solenoid valve. Both transformer wires should now be connected to the solenoid valve which should turn on immediately and run continuously.
  - If the solenoid valve does not turn on and you have made sure that there is 24-volt power coming from the transformer, you know that the solenoid has failed and will need to be replaced.
3. After replacing the solenoid valve (if necessary), reconnect the wire from the transformer to the IR module. Test the solenoid valve again.
  - If the solenoid valve does not turn on, check the wiring for proper connections. If it still fails to turn on, the problem may be in the sensor. Refer to the instructions on *Troubleshooting Adaptive Infrared* and follow the sensor troubleshooting procedure outlined there.



## Air Valve Module — Circular & Semi

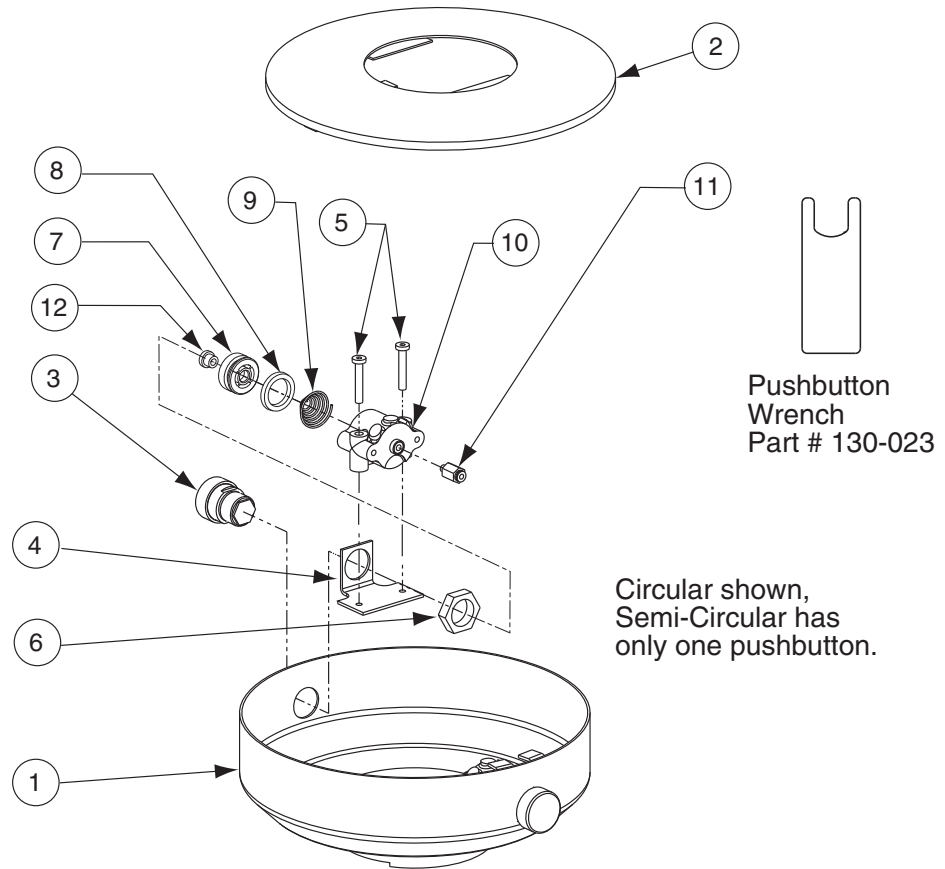

### S65-132 Air Valve Module — Circular S65-134 Air Valve Module — Semi-Circular

Item	Part No.	Description	Circular	Semi-Circular
			Qty	
1	219-017	Shell Assembly, (2 holes)	1	—
1	219-018	Shell Assembly, (1 hole)	—	1
2	S04-113	Module Cover Assembly	1	1
3	S08-324	Pushbutton Assembly	2	1
4	140-743	Actuator Bracket	2	1
5	160-165	Screw	4	2
6	110-115	Nut	2	1
*7	119-227A	Piston	2	1
*8	125-099	U-Cup	2	1
*9	135-065	Spring	2	1
*10	118-279	Actuator Body	2	1
*11	169-890	Straight Tube Connector	2	1
*12	198-010	Duckbill Check	2	1
13	269-1186	Adjustable "L" Fitting	2	1

\* Items 7-12 are available as an actuator assembly, order part number S65-168.



### Air Valve Assembly — Circular

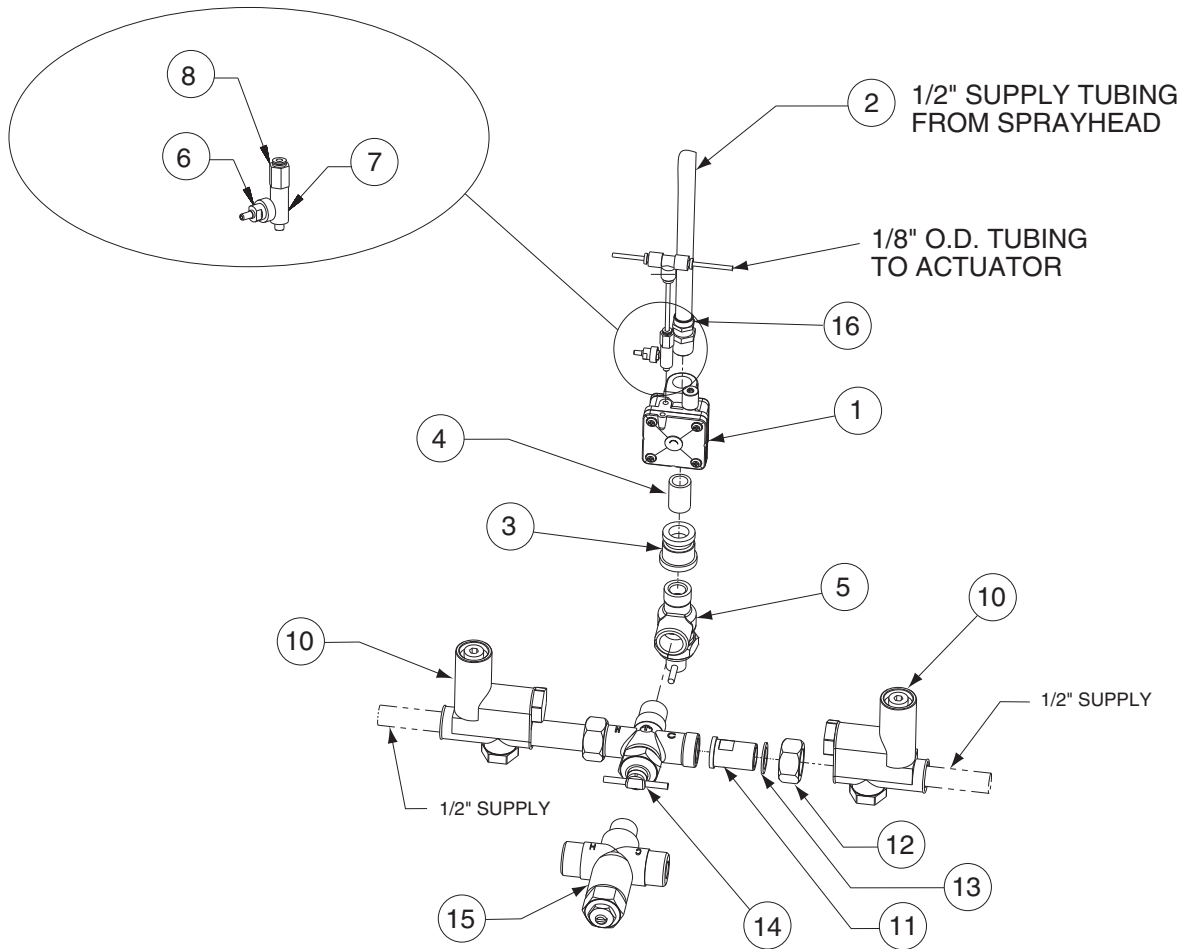

### Parts List

Item	Part No.	Description	Qty
1	S07-044	Air Valve	1
2	R68-600012	1/2" Tubing to Sprayhead	1
3	169-059	Reducer	1
4	113-006AL	3/8" Nipple	1
5	S02-045	Volume Control Valve	1
6	269-1140	Check Valve	1
7	198-008	Adapter	1
8	169-890	1/8" Tube Connector	1
9	S53-046	1/8" O.D. Tee	1
10	S60-003	Stop-Strainer-Check Valve	2
11	129-007	Tailpiece	2
12	110-005	Tailpiece Nut	2
13	124-001AF	Tailpiece Washer	2
14	S01-038	Manual Mixing Valve	1
15	S01-525	TMA (Optional)	1
16	269-626	3/8" NPT x 1/2" Tube Connector	1





# Air Valve Assembly — Semi-Circular

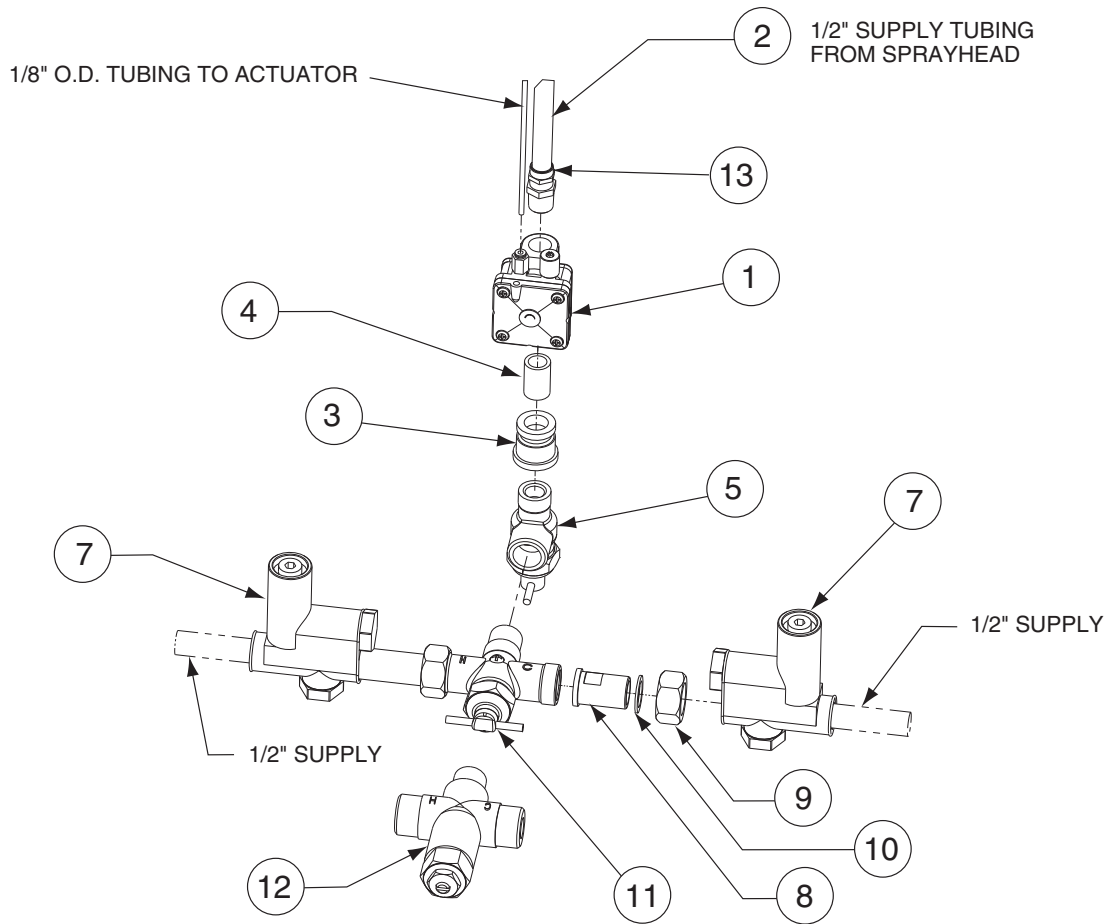

## Parts List

Item	Part No.	Description	Qty
1	S07-044	Air Valve	1
2	R68-600012	1/2" Tubing to Sprayhead	1
3	169-059	Reducer	1
4	113-006AL	3/8" Nipple	1
5	S02-045	Volume Control Valve	1
6	169-890	1/8" Tube Connector	1
7	S60-003	Stop-Strainer-Check Valve	2
8	129-007	Tailpiece	2
9	110-005	Tailpiece Nut	2
10	124-001AF	Tailpiece Washer	2
11	S01-038	Manual Mixing Valve	1
12	S01-525	TMA (Optional)	1
13	269-626	3/8" NPT x 1/2" Tube Connector	1

## Air Valve Tubing Connection

*If the air valve is leaking.*

1. Depress the release button per the Figure below.
2. Remove and trim the tubing for a fresh surface.
3. Reinsert the tubing until it seats on the tube stop.

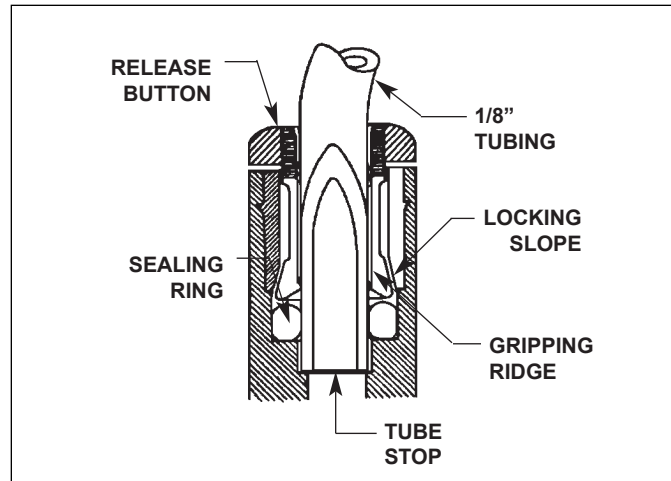

## Adjusting the Air Valve Metering Time

*Note: The air valve timer is located next to the tube connector on the air valve body. The timer is capped with a filter to prevent dirt build-up on the timer. The air valve timing can be adjusted from 5-45 seconds. Refer to Figure below when adjusting the air valve.*

1. Remove the filter cap. Use a screwdriver to tighten or loosen the timer. Turning the timer clockwise increases the time, turning the timer counterclockwise decreases the time.
2. Continue to adjust the timer until it is set at the desired length.
3. Replace the filter cap.

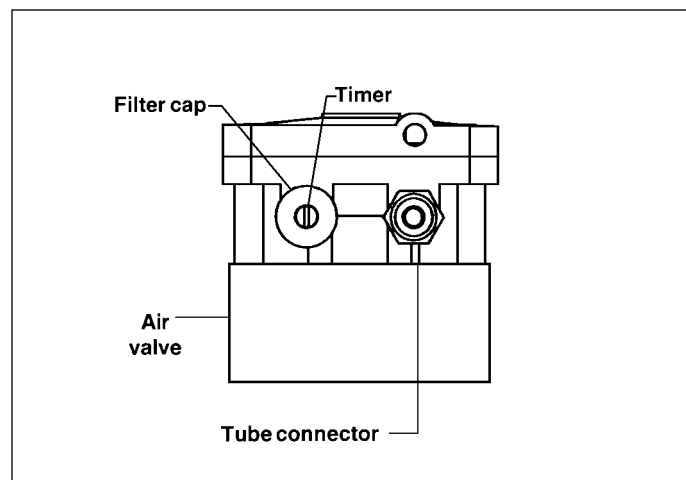



## Air Valve Troubleshooting

### **Problem: Valve will not shut off.**

*Cause: Timing mechanism is clogged.*

Solution: Clean and inspect timing mechanism:

1. If compressed air is available, blow water and debris from perforated metal sleeve of timing mechanism.
2. Turn adjusting screw in all the way but do not force screw.
3. Turn adjusting screw out to desired cycle time.

### **Problem: Valve will not turn on.**

*Cause: Water is not being supplied to unit.*

Solution: Open all stops on mixing valve.

### **Problem: Timing can not be adjusted for more than 5 seconds.**

*Cause: There is an air leak*

Solution: Check the valve assembly:

1. Check all tubing and fittings for proper assembly.
2. Tighten all screws which hold valve together.

### **Problem: Push button does not work properly.**

*Cause: Air volume may not be sufficient to operate valve.*

Solution: Check for leaks and lubricate U-cup:

1. Check all fittings for air leaks.
2. Disassemble pushbutton and lubricate U-cup seal.

### **Problem: Water is dripping from the aerator.**

*Cause: Debris has accumulated on valve seat or orifices.*

Solution: Clean and inspect valve seat.

1. Remove screws and disassemble metering valve.
2. Clean valve seat and inspect for deep gouges or scratches. Replace if necessary.
3. Remove all debris that may be clogging center hole of plastic diaphragm assembly.
4. Remove any debris clogging off-center hole in rubber diaphragm.