



**COMMERCIAL REPLACEMENT PARTS LIST**  
**Commercial Gas**  
**Electronic Ignition Models**



Includes Hydrojet<sup>®</sup>  
Total Performance System

***Effective: December, 2011***  
***ECO 7615***

**NOTE: BOTH MODEL AND SERIAL  
NUMBERS ARE REQUIRED FOR  
ORDERING REPLACEMENT PARTS**

Dimensions and specifications  
subject to change without notice.

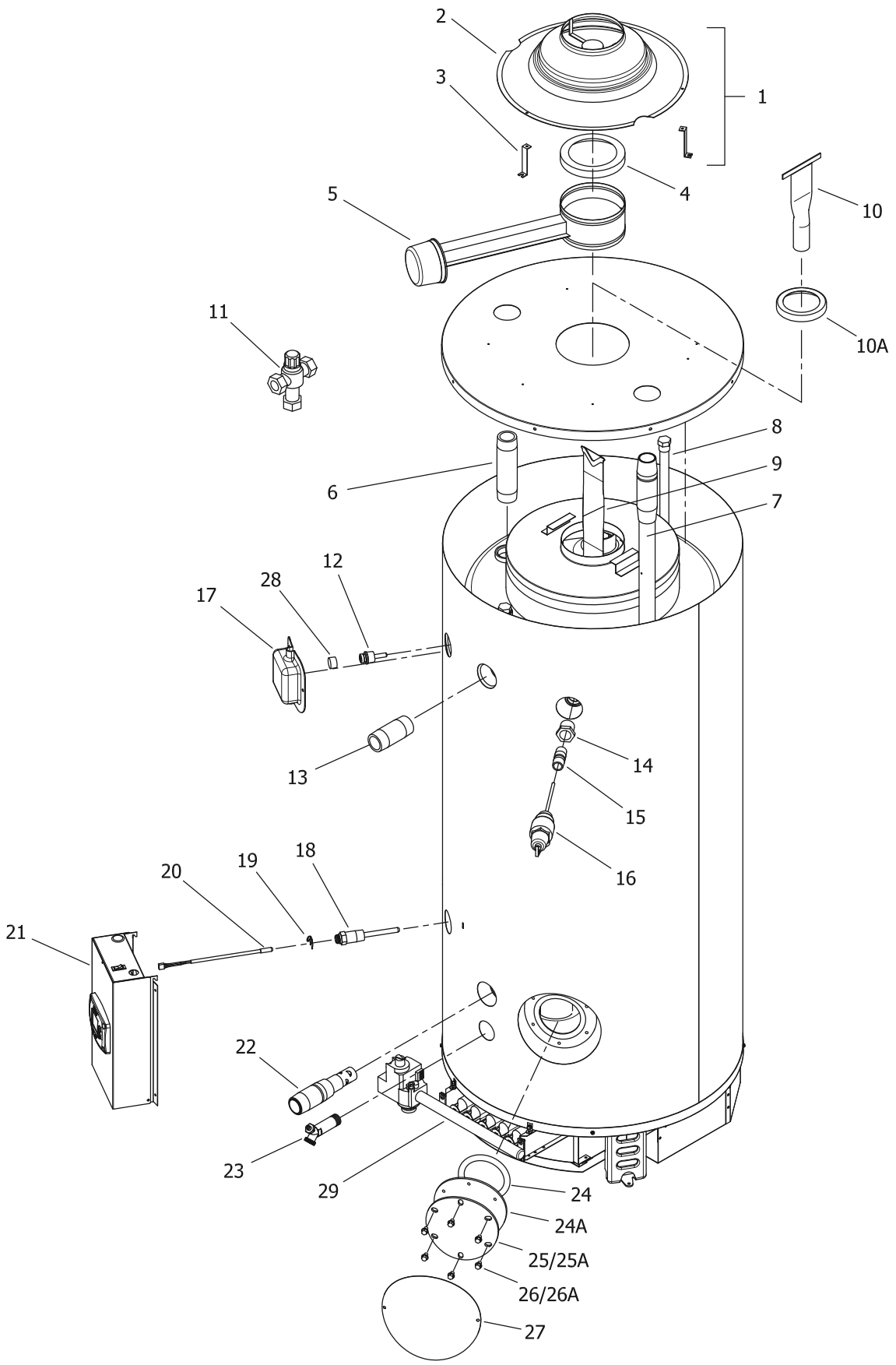

Item	Description	Model	Model	Model	Model	Model
		D38T155(E)*(N,X)	D65T370(E)*(N,X)(A)	D65T399(E)*(N)(A)	D75T125(E)*(N,X)	D75T160(E)*(N,X)
1	Draft Diverter Complete with Leg Kit	265-46541-00	265-46546-00	265-46546-00	265-46542-00	265-46543-00
2	Draft Diverter Only	243-81733-00-01	243-81992-00-01	243-81992-00-01	243-82000-01-01	243-81998-00-01
3	Draft Diverter Leg Kit Only	243-43690-02	243-43691-04	243-43691-04	243-43689-02	243-43690-06
4	Flue Damper Reducer	---	---	---	239-81980-00	239-81980-00
5	Flue Damper Complete	265-42973-00	265-42974-00	265-42974-00	265-43112-00	265-43112-00
6	Hot Water Outlet Nipple (Top)	---	---	---	229-40913-01	229-40913-01
7	Cold Water Inlet Diptube (Top)	---	---	---	229-46709-01	229-46709-01
8	Plug Type Anode Rod (Magnesium)	224-47782-09 (Qty. 3)	224-47782-11 (Qty. 3)	224-47782-11 (Qty. 3)	224-47782-06 (Qty. 2)	224-47782-06 (Qty. 2)
9	Plug Type Anode Rod (Aluminum)	224-47783-02 (Qty. 3)	224-47783-07 (Qty. 3)	224-47783-07 (Qty. 3)	224-47783-06 (Qty. 2)	224-38508-06 (Qty. 2)
10	Flue Baffle	243-81683-00 (Qty. 11)	243-39327-00 (Qty. 16)	243-82076-00 (Qty. 16)	---	---
11	Flue Core	---	---	---	239-81476-00 (Qty. 2)	---
12	Flue Reducer	---	---	---	243-36920-00	243-36920-00
13	ASSE Approved Mixing Valve (Optional)	239-43740-02	239-43740-02	239-43740-02	239-43740-02	239-43740-02
14	Upper Thermostat Sensor	---	239-82033-00	239-82033-00	---	---
15	Hot Water Outlet Nipple (Side)	229-40913-02	229-40913-02	229-40913-02	229-40913-02	229-40913-02
16	1" NPT to 3/4" NPT Reducer Bushing	239-02052-00	---	---	---	---
17	3/4" NPT Nipple	229-32762-04	---	---	229-32762-04	229-32762-04
18	1" NPT Nipple	---	229-32762-19	229-32762-19	---	---
19	T&P Valve	230-30246-00	230-33630-04	230-33630-04	230-30246-00	230-30246-00
20	Utility Cover	---	239-80281-03	239-80281-03	239-80281-03	239-80281-03
21	Lower Thermostat Well	233-46558-02	233-46558-02	233-46558-02	233-46558-02	233-46558-02
22	Clip for Lower Thermostat	233-45242-00	233-45242-00	233-45242-00	233-45242-00	233-45242-00
23	Lower Thermostat Sensor	239-46553-01	239-46553-02	239-46553-02	239-46553-02	239-46553-02
24	Control Box Assembly	243-46614-01	243-46560-01	243-46560-01	243-46614-02	243-46614-02
25	Cold Water Inlet Diptube (Side)	229-44731-00	229-44731-00	229-44731-00	229-44731-00	229-44731-00
26	Brass Drain Valve	265-42351-04	265-42351-04	265-42351-04	265-42351-04	265-42351-04
27	Cleanout O-Ring Gasket	205-18427-00	205-18427-00	205-18427-00	205-18427-00	205-18427-00
28	Cleanout Gasket (ASME)	---	205-32942-00	205-32942-00	---	---
29	Cleanout Cover	205-18428-00	205-18428-00	205-18428-00	205-18428-00	205-18428-00
30	Cleanout Cover (ASME)	---	205-32941-00	205-32941-00	---	---
31	Cleanout Cover Screw	239-82166-00 (Qty. 6)	239-82166-00 (Qty. 6)	239-82166-00 (Qty. 6)	239-82166-00 (Qty. 6)	239-82166-00 (Qty. 6)
32	Cleanout Cover Screw (ASME)	---	239-32970-00 (Qty. 6)	239-32970-00 (Qty. 6)	---	---
33	Cleanout Access Cover	243-20299-00	243-20299-00	243-20299-00	243-20299-00	243-20299-00
34	Pipe plug (3/4 NPT)	---	---	---	---	---

\* Applies to all warranties  
 \*\* Ordering a complete burner rack may increase delivery time. Please order the specific component required for the quickest delivery.  
 \*\*\* No LP version model available.  
 \*\*\*\* No Low Nox versions available over 400K btuh.

▲ Applies when "E" is present in model number (Example: D38T155E3N).  
 1 For serial numbers PRIOR to GB13067706.  
 2 For serial numbers AFTER and including GB13067706.  
 3 For serial numbers PRIOR to HA14465923.  
 4 For serial numbers including and AFTER HA14465923



Item	Description	Model	Model	Model	Model	Model	Model
		D38T155(E)*(N,X)	D65T370(E)*(N,X)(A)	D65T399(E)*N(A)	D75T125(E)*(N,X)	D75T160(E)*(N,X)	
29	Burner Rack Complete (Natural Gas) **	243-39205-18	243-39322-01	243-39322-03	243-39334-01	243-39205-03	
	Burner Rack Complete (Nat. Gas)(Lo NOX) **▲	243-42563-05	243-42558-01	243-42558-02	243-42559-01	243-42563-01	
	Burner Rack Complete (LP Gas) **	243-39205-04	243-39322-02	***	243-39334-02	243-39205-04	
30	Burner Rack Only	239-81969-01	239-81969-03	239-81969-03	243-82107-00	233-81969-01	
31	Gas Valve (Natural Gas)	222-80830-02	222-81608-03	222-81608-03	222-80830-02	222-80830-02	
	Gas Valve (LP Gas)	222-80831-02	222-80831-02	***	222-80831-02	222-80831-02	
32	Burner Tube (Standard)	228-39177-00 (Qty. 5)	228-39177-00 (Qty. 9)	228-39177-00 (Qty. 9)	228-39177-00 (Qty. 3)	228-39177-00 (Qty. 5)	
	Burner Tube (Lo-NOX) ▲	228-42490-00 (Qty. 5)	228-42490-00 (Qty. 9)	228-42490-00 (Qty. 9)	228-42490-00 (Qty. 3)	228-42490-00 (Qty. 5)	
	Burner Tube (Stainless Steel)	228-81964-00 (Qty. 5)	228-81964-00 (Qty. 9)	228-81964-00 (Qty. 9)	228-81964-00 (Qty. 3)	228-81964-00 (Qty. 5)	
33	Burner Manifold (Nat.gas)	233-39170-00	---	---	233-39174-00	233-39170-00	
	Burner Manifold (LP gas)	233-39170-00	---	---	233-39174-00	233-39170-00	
33A	Burner Manifold (Nat.gas)	---	---	---	---	---	
	Burner Manifold (LP gas)	---	---	---	---	---	
33B	Burner Manifold (LP gas)	---	233-39173-00	---	---	---	
	Burner Manifold (Nat.gas)	---	233-39171-00	233-39171-00	---	---	
34	Main Burner Orifice (Natural Gas) (0ft to 2000ft)	234-06016-73 (Qty. 5)	234-06016-33 (Qty. 9)	234-06016-32 (Qty. 9)	234-06016-33 (Qty. 3)	234-06016-39 (Qty. 5)	
	High Altitude (Natural Gas) (2001ft to 5000ft)	234-06016-42 (Qty. 5)	234-06016-36 (Qty. 9)	234-06016-35 (Qty. 9)	234-06016-36 (Qty. 3)	234-06016-42 (Qty. 5)	
	High Altitude (Natural Gas) (5001ft to 8000ft)	234-06016-43 (Qty. 5)	234-06016-38 (Qty. 9)	234-06016-37 (Qty. 9)	234-06016-38 (Qty. 3)	234-06016-43 (Qty. 5)	
	High Altitude (Natural Gas) (8001ft & above)	234-06016-44 (Qty. 5)	234-06016-39 (Qty. 9)	234-06016-38 (Qty. 9)	234-06016-39 (Qty. 3)	234-06016-44 (Qty. 5)	
	Main Burner Orifice (LP Gas) (0ft to 2000ft)	234-06016-52 (Qty. 5)	234-06016-49 (Qty. 9)	***	234-06016-48 (Qty. 3)	234-06016-52 (Qty. 5)	
	High Altitude (LP Gas) (2001ft to 5000ft)	234-06016-116 (Qty. 5)	234-06016-50 (Qty. 9)	***	234-06016-50 (Qty. 3)	234-06016-116 (Qty. 5)	
	High Altitude (LP Gas) (5001ft to 8000ft)	234-06016-53 (Qty. 5)	234-06016-51 (Qty. 9)	***	234-06016-51 (Qty. 3)	234-06016-53 (Qty. 5)	
	High Altitude (LP Gas) (8001ft & above)	234-06016-53 (Qty. 5)	234-06016-51 (Qty. 9)	***	234-06016-51 (Qty. 3)	234-06016-53 (Qty. 5)	
35	Pilot Shield	239-41333-00	239-41333-00	239-41333-00	239-41333-00	239-41333-00	
36	Pilot Assembly (Natural Gas)	239-41323-01	239-41323-01	239-41323-01	239-41323-01	239-41323-01	
	Pilot Assembly (LP Gas)	233-41323-02	233-41323-02	233-41323-02	233-41323-02	233-41323-02	
37	Pilot Orifice (Natural Gas)	233-41606-01	233-41606-01	233-41606-01	233-41606-01	233-41606-01	
	Pilot Orifice (LP Gas)	233-41606-02	233-41606-02	233-41606-02	233-41606-02	233-41606-02	
38	Aluminum Pilot Tube	233-80361-01	233-80361-01	233-80361-01	233-80361-01	233-80361-01	
39	Burner Support	239-45180-00	239-39259-00	239-39259-00	239-45180-00	239-45180-00	
40	Draft Panel	239-39419-00	239-39421-00	239-39421-00	239-39419-00	239-39419-00	
41	Pilot Mounting Screw	239-11706-00 (Qty. 2)	239-11706-00 (Qty. 2)	239-11706-00 (Qty. 2)	239-11706-00 (Qty. 2)	239-11706-00 (Qty. 2)	
42	Street Elbow 1" NPT (Nat.)	---	239-19636-00	***	---	---	
43	Pipe Nipple 1" NPT (Nat.)	---	239-81595-00	***	---	---	
44	Elbow 1" NPT (Nat.)	---	239-19637-00	***	---	---	
45	Gas Support Bracket (Nat.)	---	239-81816-01	239-81816-01	---	---	
	Gas Support Bracket (LP)	---	239-81816-02	***	---	---	
46	Ground Wire	239-38951-52	239-38951-52	239-38951-52	239-38951-52	239-38951-52	
-	LP to Natural Gas Conversion Kit	265-46033-01	265-46034-01	***	265-46033-02	265-46033-03	

\* Applies to all warranties  
 \*\* Ordering a complete burner rack may increase delivery time. Please order the specific component required for the quickest delivery.  
 \*\*\* No LP version model available.  
 \*\*\*\* No Low Nox versions available over 400K btuh.

▲ Applies when "E" is present in model number (Example: D38T155E3N).

1 For serial numbers PRIOR to GB13067706.  
 2 For serial numbers AFTER and including GB13067706.  
 3 For serial numbers PRIOR to HA14465923.  
 4 For serial numbers including and AFTER HA14465923

21

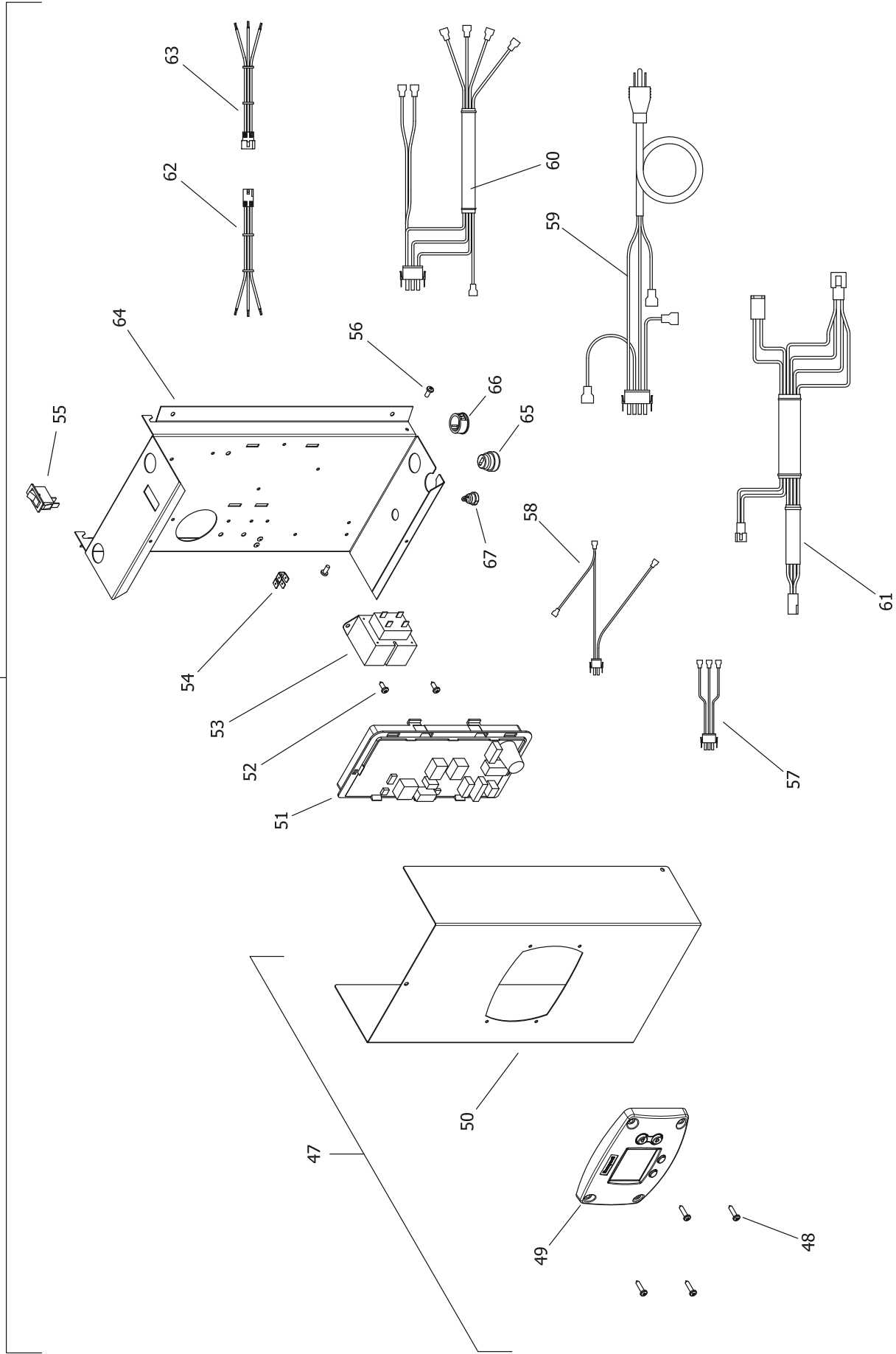

Item	Description	Model D38T155(E)*(N,X)	Model D65T370(E)*(N,X)(A)	Model D65T399(E)*(N)(A)	Model D75T125(E)*(N,X)	Model D75T160(E)*(N,X)
21	Control Box Assembly (Dual Sensor)	---	243-46560-01	243-46560-01	---	---
	Control Box Assembly (Single Sensor)	243-46614-01	---	---	243-46614-02	243-46614-02
47	Control Box Cover Assembly	243-46615-01	243-46615-01	243-46615-01	243-46615-01	243-46615-01
48	Screw #8-18 X 3/4 Pan Head CR	239-43863-00	239-43863-00	239-43863-00	239-43863-00	239-43863-00
49	Honeywell Temperature Control Display	233-46557-00	233-46557-00	233-46557-00	233-46557-00	233-46557-00
50	Control Box Cover	239-46509-00	239-46509-00	239-46509-00	239-46509-00	239-46509-00
51	Integrated Control Board (Dual Sensor)	---	233-46616-00	233-46616-00	---	---
	Integrated Control Board (Single Sensor)	233-47260-00	---	---	233-47260-00	233-47260-00
52	Screw #8-18 X 1/2 Pan Head CR	239-43736-00	239-43736-00	239-43736-00	239-43736-00	239-43736-00
53	Transformer 110V	233-44072-01	233-44072-01	233-44072-01	233-44072-01	233-44072-01
54	Ground Lug 1/4 x .032	239-80112-00	239-80112-00	239-80112-00	239-80112-00	239-80112-00
55	Power On/Off Switch	239-41566-00	239-41566-00	239-41566-00	239-41566-00	239-41566-00
56	Screw 8/32 X 1/4 Pan Head CR w/adh.	239-46522-00	239-46522-00	239-46522-00	239-46522-00	239-46522-00
57	Primary Transformer Wiring Harness	239-46531-00	239-46531-00	239-46531-00	239-46531-00	239-46531-00
58	Secondary Transformer Wiring Harness	239-46530-00	239-46530-00	239-46530-00	239-46530-00	239-46530-00
59	Power Cord Wiring Harness	239-46533-00	239-46533-00	239-46533-00	239-46533-00	239-46533-00
60	Gas Valve Control Wiring Harness	239-46529-01	239-46529-01	239-46529-01	239-46529-01	239-46529-01
61	Damper Wiring Harness (Dual Sensor)	---	239-46526-04	239-46526-04	---	---
	Damper Wiring Harness (Single Sensor)	239-46527-01	---	---	239-46527-03	239-46527-03
62	Display Control Wiring Harness	239-46944-00	239-46944-00	239-46944-00	239-46944-00	239-46944-00
63	Display Cover Wiring Harness	239-46617-00	239-46617-00	239-46617-00	239-46617-00	239-46617-00
64	Control Box Panel	239-46508-00	239-46508-00	239-46508-00	239-46508-00	239-46508-00
65	Strain Relief Bushing 7/8"	239-80372-00	239-80372-00	239-80372-00	239-80372-00	239-80372-00
66	Snap-in Bushing 7/8"	239-80406-00	239-80406-00	239-80406-00	239-80406-00	239-80406-00
67	Strain Relief Bushing 1/2"	239-44575-00	239-44575-00	239-44575-00	239-44575-00	239-44575-00

\* Applies to all warranties

\*\* Ordering a complete burner rack may increase delivery time. Please order the specific component required for the quickest delivery.

\*\*\* No LP version model available.

\*\*\*\* No Low Nox versions available over 400K btuh.

▲ Applies when "E" is present in model number (Example: D38T155E3N).

- 1 For serial numbers PRIOR to GB13067706.
- 2 For serial numbers AFTER and including GB13067706.
- 3 For serial numbers PRIOR to HA14465923.
- 4 For serial numbers including and AFTER HA14465923

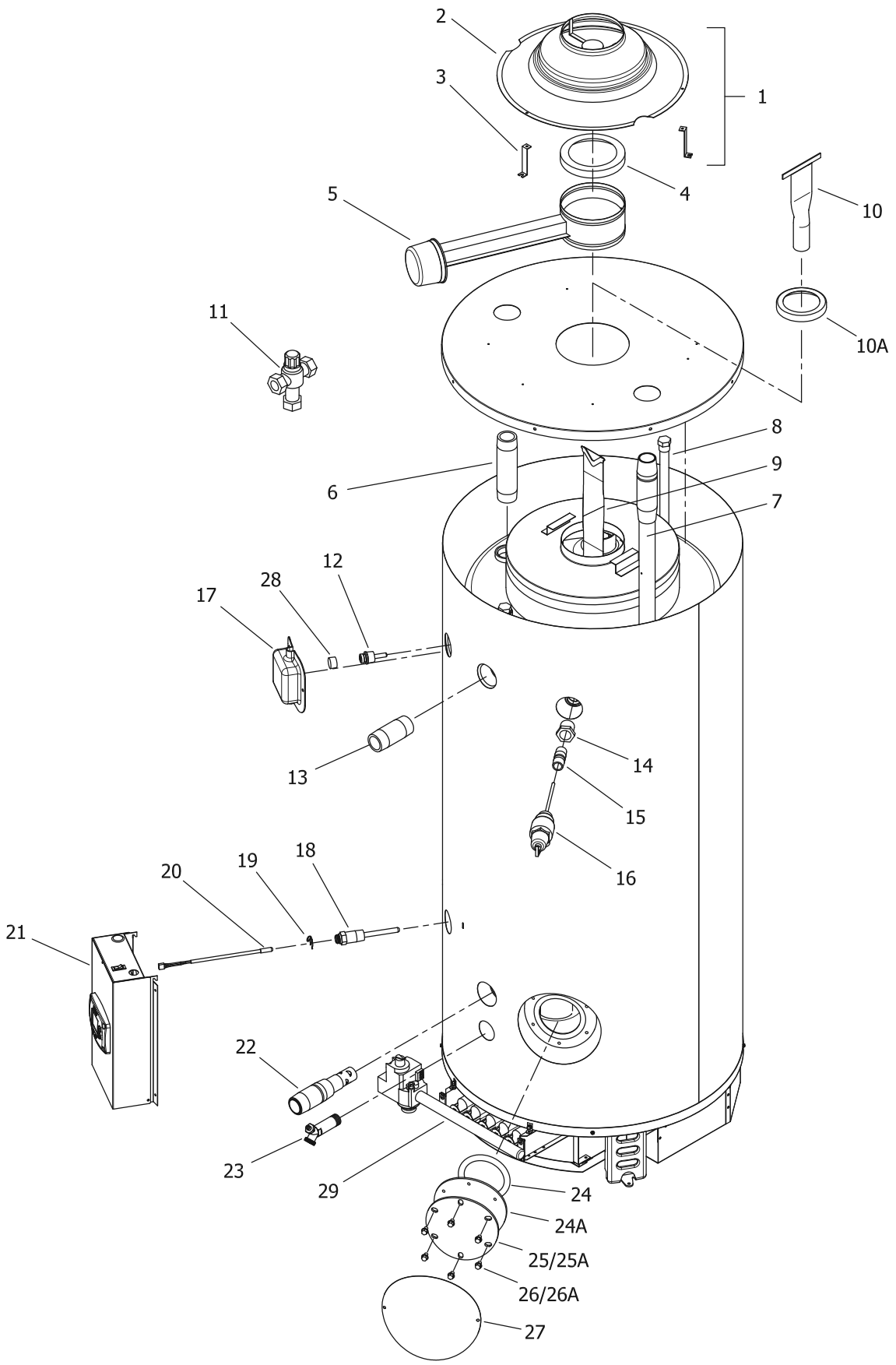



Item	Description	Model D75T300*(N,X)(A)	Model D80L399(E)*(N,X)(A)	Model D80L450*(N,X)(A)	Model D80L505*(N,X)(A)	Model D80T180(E)*(N,X)
1	Draft Diverter Complete with Leg Kit	265-46545-00	265-46551-00	265-46552-00	265-46552-00	265-46544-00
2	Draft Diverter Only	243-81502-00-01	243-81779-00-01	243-81739-00-01	243-81739-00-01	243-81986-00-01
3	Draft Diverter Leg Kit Only	243-43690-04	243-43690-07	243-43690-05	243-43690-05	243-43690-02
4	Flue Damper Reducer	---	239-81812-00	---	---	---
5	Flue Damper Complete	265-42974-00	265-43114-00	265-42975-00	265-42975-00	265-42973-00
6	Hot Water Outlet Nipple (Top)	---	---	---	---	229-40913-01
7	Cold Water Inlet Diptube (Top)	---	---	---	---	229-46709-03
8	Plug Type Anode Rod (Magnesium)	224-47782-06 (Qty. 3)	224-47782-10 (Qty. 4)	224-47782-10 (Qty. 4)	224-47782-10 (Qty. 4)	224-47782-11 (Qty. 2)
9	Plug Type Anode Rod (Aluminum)	224-38508-06 (Qty. 3)	224-47783-05 (Qty. 4)	224-47783-05 (Qty. 4)	224-47783-05 (Qty. 4)	224-47783-07 (Qty. 2)
10	Flue Baffle	243-82076-00 (Qty. 11)	243-81747-00 (Qty. 20)	243-81730-00 (Qty. 20)	243-81747-00 (Qty. 20)	243-81563-00 (Qty. 8)
11	Flue Reducer	---	---	---	---	---
12	ASSE Approved Mixing Valve (Optional)	239-43740-02	239-43740-02	239-43740-02	239-43740-02	239-43740-02
13	Upper Thermostat Sensor	239-82033-00	239-82033-00	239-82033-00	239-82033-00	239-82033-00
14	Hot Water Outlet Nipple (Side)	229-40913-02	229-40913-02	229-40913-02	229-40913-02	229-40913-02
15	1" NPT to 3/4" NPT Reducer Bushing	---	---	---	---	239-02052-00
16	3/4" NPT Nipple	229-32762-19	239-80982-00	239-80982-00	239-80982-00	229-32762-04
17	T&P Valve	230-33630-04	230-33630-04	230-33630-04	230-33630-04	230-30246-00
18	Utility Cover	239-80281-03	239-80281-03	239-80281-03	239-80281-03	239-80281-03
19	Lower Thermostat Well	233-46558-02	233-46558-01	233-46558-01	233-46558-01	233-46558-02
20	Clip for Lower Thermostat	233-45242-00	233-45242-00	233-45242-00	233-45242-00	233-45242-00
21	Lower Thermostat Sensor	239-46553-02	239-46553-01	239-46553-01	239-46553-01	239-46553-01
22	Control Box Assembly	243-46560-01	243-46560-01	243-46560-01	243-46560-01	243-46560-03
23	Cold Water Inlet Diptube (Side)	229-44731-00	229-44731-00	229-44731-00	229-44731-00	229-44731-00
24	Brass Drain Valve	265-42351-04	265-42351-04	265-42351-04	265-42351-04	265-42351-04
25	Cleanout O-Ring Gasket	205-18427-00	205-18427-00	205-18427-00	205-18427-00	205-18427-00
26	Cleanout Gasket (ASME)	205-32942-00	205-32942-00	205-32942-00	205-32942-00	---
27	Cleanout Cover	205-18428-00	205-18428-00	205-18428-00	205-18428-00	205-18428-00
28	Cleanout Cover (ASME)	205-32941-00	205-32941-00	205-32941-00	205-32941-00	---
29	Cleanout Cover Screw	239-82166-00 (Qty. 6)	239-82166-00 (Qty. 6)	239-82166-00 (Qty. 6)	239-82166-00 (Qty. 6)	239-82166-00 (Qty. 6)
30	Cleanout Cover Screw (ASME)	239-32970-00 (Qty. 6)	239-32970-00 (Qty. 6)	239-32970-00 (Qty. 6)	239-32970-00 (Qty. 6)	---
31	Cleanout Access Cover	243-20299-00	243-20299-00	243-20299-00	243-20299-00	243-20299-00
32	Pipe plug (3/4 NPT)	---	---	---	---	---

\* Applies to all warranties  
 \*\* Ordering a complete burner rack may increase delivery time. Please order the specific component required for the quickest delivery.  
 \*\*\* No LP version model available.  
 \*\*\*\* No Low Nox versions available over 400K btuh.

▲ Applies when "E" is present in model number (Example: D38T155E3N).  
 1 For serial numbers PRIOR to GB13067706.  
 2 For serial numbers AFTER and including GB13067706.  
 3 For serial numbers PRIOR to HA14465923.  
 4 For serial numbers including and AFTER HA14465923



Item	Description	Model	Model	Model	Model	Model	Model
		D75T300*(N,X)(A)	D80L399(E)*(N,X)(A)	D80L450*(N,X)(A)	D80L505*(N,X)(A)	D80T180(E)*(N,X)	
29	Burner Rack Complete (Natural Gas) **	243-39343-01	243-81788-01	243-81788-03	243-81788-05	243-39205-07	
	Burner Rack Complete (Nat. Gas)(Lo NOx) **▲	243-42560-01	243-42562-01	*****	*****	243-42563-03	
	Burner Rack Complete (LP Gas) **	243-39343-02	243-81788-02	243-81788-04	243-81788-06	243-39205-08	
30	Burner Rack Only	239-81969-02	239-81969-03	239-81969-03	239-81969-03	233-81969-01	
31	Gas Valve (Natural Gas)	222-80830-02	222-81608-03	222-81608-03	222-81608-03	222-80830-02	
	Gas Valve (LP Gas)	222-80831-02	222-80831-02	222-80831-02	222-80831-02	222-80831-02	
32	Burner Tube (Standard)	228-39177-00 (Qty. 7)	228-39177-00 (Qty. 9)	228-39177-00 (Qty. 9)	228-39177-00 (Qty. 9)	228-39177-00 (Qty. 5)	
	Burner Tube (Lo-NOx) ▲	228-42490-00 (Qty. 7)	228-42490-00 (Qty. 9)	*****	228-42490-00 (Qty. 9)	228-42490-00 (Qty. 5)	
	Burner Tube (Stainless Steel)	228-81964-00 (Qty. 7)	228-81964-00 (Qty. 9)	228-81964-00 (Qty. 9)	228-81964-00 (Qty. 9)	228-81964-00 (Qty. 5)	
33	Burner Manifold (Nat.gas)	---	---	---	---	233-39170-00	
	Burner Manifold (LP gas)	233-39172-00	---	---	---	233-39170-00	
33A	Burner Manifold (Nat.gas)	233-39172-00	233-39173-00	233-39173-00	233-39173-00	---	
	Burner Manifold (LP gas)	---	233-39171-00	233-39171-00	233-39171-00	---	
33B	Burner Manifold (Nat.gas)	---	233-39171-00	233-39171-00	233-39171-00	---	
34	Main Burner Orifice (Natural Gas) (0ft to 2000ft)	234-06016-32 (Qty. 7)	234-06016-32 (Qty. 9)	234-06016-18 (Qty. 9)	234-06016-30 (Qty. 9)	234-06016-37 (Qty. 5)	
	High Altitude (Natural Gas) (2001ft to 5000ft)	234-06016-36 (Qty. 7)	234-06016-35 (Qty. 9)	234-06016-32 (Qty. 9)	234-06016-18 (Qty. 9)	234-06016-39 (Qty. 5)	
	High Altitude (Natural Gas) (5001ft to 8000ft)	234-06016-37 (Qty. 7)	234-06016-37 (Qty. 9)	234-06016-34 (Qty. 9)	234-06016-32 (Qty. 9)	234-06016-42 (Qty. 5)	
	High Altitude (Natural Gas) (8001ft & above)	234-06016-38 (Qty. 7)	234-06016-38 (Qty. 9)	234-06016-35 (Qty. 9)	234-06016-32 (Qty. 9)	234-06016-42 (Qty. 5)	
	Main Burner Orifice (LP Gas) (0ft to 2000ft)	234-06016-48 (Qty. 7)	234-06016-48 (Qty. 9)	234-06016-46 (Qty. 9)	234-06016-44 (Qty. 9)	234-06016-50 (Qty. 5)	
	High Altitude (LP Gas) (2001ft to 5000ft)	234-06016-50 (Qty. 7)	234-06016-50 (Qty. 9)	234-06016-48 (Qty. 9)	234-06016-45 (Qty. 9)	234-06016-51 (Qty. 5)	
	High Altitude (LP Gas) (5001ft to 8000ft)	234-06016-51 (Qty. 7)	234-06016-51 (Qty. 9)	234-06016-49 (Qty. 9)	234-06016-47 (Qty. 9)	234-06016-1/16 (Qty. 5)	
	High Altitude (LP Gas) (8001ft & above)	234-06016-51 (Qty. 7)	234-06016-51 (Qty. 9)	234-06016-49 (Qty. 9)	234-06016-48 (Qty. 9)	234-06016-1/16 (Qty. 5)	
35	Pilot Shield	239-41333-00	239-41333-00	239-41333-00	239-41333-00	239-41333-00	
36	Pilot Assembly (Natural Gas)	239-41323-01	239-41323-01	239-41323-01	239-41323-01	239-41323-01	
	Pilot Assembly (LP Gas)	233-41323-02	233-41323-02	233-41323-02	233-41323-02	233-41323-02	
37	Pilot Orifice (Natural Gas)	233-41606-01	233-41606-01	233-41606-01	233-41606-01	233-41606-01	
	Pilot Orifice (LP Gas)	233-41606-02	233-41606-02	233-41606-02	233-41606-02	233-41606-02	
38	Aluminum Pilot Tube	233-80361-01	233-80361-01	233-80361-01	233-80361-01	233-80361-01	
39	Burner Support	239-45181-00	239-39259-00	239-39259-00	239-39259-00	239-45180-00	
40	Draft Panel	239-39420-00	239-39421-00	239-39421-00	239-39421-00	239-39419-00	
41	Pilot Mounting Screw	239-11706-00 (Qty. 2)	239-11706-00 (Qty. 2)	239-11706-00 (Qty. 2)	239-11706-00 (Qty. 2)	239-11706-00 (Qty. 2)	
42	Street Elbow 1" NPT (Nat.)	---	239-19636-00	239-19636-00	239-19636-00	---	
43	Pipe Nipple 1" NPT (Nat.)	---	239-81595-00	239-81595-00	239-81595-00	---	
44	Elbow 1" NPT (Nat.)	---	239-19637-00	239-19637-00	239-19637-00	---	
45	Gas Support Bracket (Nat.)	---	239-44517-00	239-44517-00	239-44517-00	---	
	Gas Support Bracket (LP)	239-81816-03	239-81816-02	239-81816-02	239-81816-02	---	
46	Ground Wire	239-38951-52	239-38951-52	239-38951-52	239-38951-52	239-38951-52	
-	LP to Natural Gas Conversion Kit	265-46033-04	265-46034-06	265-46034-07	265-46034-08	265-46033-05	

\* Applies to all warranties ▲ Applies when "E" is present in model number (Example: D38T155E3N).

\*\* Ordering a complete burner rack may increase delivery time. Please order the specific component required for the quickest delivery.

\*\*\* No LP version model available.

\*\*\*\* No Low Nox versions available over 400K btuh.

1 For serial numbers PRIOR to GB13067706.

2 For serial numbers AFTER and including GB13067706.

3 For serial numbers PRIOR to HA14465923.

4 For serial numbers including and AFTER HA14465923

21

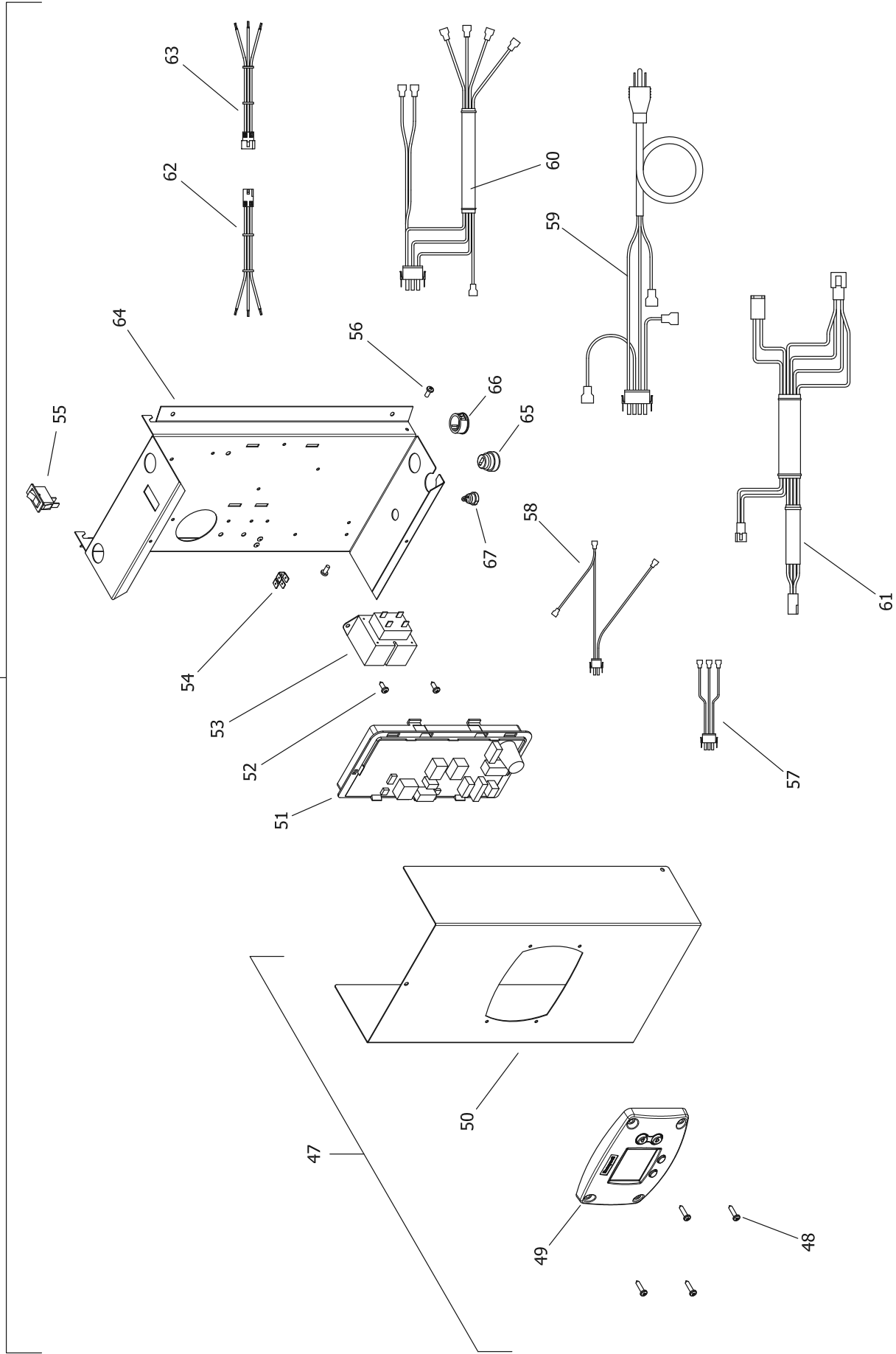

Item	Description	Model	Model	Model	Model	Model
		D75T300*(N,X)(A)	D80L399(E)*(N,X)(A)	D80L450*(N,X)(A)	D80L505*(N,X)(A)	D80T180(E)*(N,X)
21	Control Box Assembly (Dual Sensor)	243-46560-01	243-46560-01	243-46560-01	243-46560-01	243-46560-03
	Control Box Assembly (Single Sensor)					
47	Control Box Cover Assembly	243-46615-01	243-46615-01	243-46615-01	243-46615-01	243-46615-01
48	Screw #8-18 X 3/4 Pan Head CR	239-43863-00	239-43863-00	239-43863-00	239-43863-00	239-43863-00
49	Honeywell Temperature Control Display	233-46557-00	233-46557-00	233-46557-00	233-46557-00	233-46557-00
50	Control Box Cover	239-46509-00	239-46509-00	239-46509-00	239-46509-00	239-46509-00
51	Integrated Control Board (Dual Sensor)	233-46616-00	233-46616-00	233-46616-00	233-46616-00	233-46616-00
	Integrated Control Board (Single Sensor)					
52	Screw #8-18 X 1/2 Pan Head CR	239-43736-00	239-43736-00	239-43736-00	239-43736-00	239-43736-00
53	Transformer 110V	233-44072-01	233-44072-01	233-44072-01	233-44072-01	233-44072-01
54	Ground Lug 1/4 x .032	239-80112-00	239-80112-00	239-80112-00	239-80112-00	239-80112-00
55	Power On/Off Switch	239-41566-00	239-41566-00	239-41566-00	239-41566-00	239-41566-00
56	Screw 8/32 X 1/4 Pan Head CR w/adh.	239-46522-00	239-46522-00	239-46522-00	239-46522-00	239-46522-00
57	Primary Transformer Wiring Harness	239-46531-00	239-46531-00	239-46531-00	239-46531-00	239-46531-00
58	Secondary Transformer Wiring Harness	239-46530-00	239-46530-00	239-46530-00	239-46530-00	239-46530-00
59	Power Cord Wiring Harness	239-46533-00	239-46533-00	239-46533-00	239-46533-00	239-46533-00
60	Gas Valve Control Wiring Harness	239-46529-01	239-46529-01	239-46529-01	239-46529-01	239-46529-01
61	Damper Wiring Harness (Dual Sensor)	239-46526-04	239-46526-04	239-46526-04	239-46526-04	239-46526-02
	Damper Wiring Harness (Single Sensor)					
62	Display Control Wiring Harness	239-46944-00	239-46944-00	239-46944-00	239-46944-00	239-46944-00
63	Display Cover Wiring Harness	239-46617-00	239-46617-00	239-46617-00	239-46617-00	239-46617-00
64	Control Box Panel	239-46508-00	239-46508-00	239-46508-00	239-46508-00	239-46508-00
65	Strain Relief Bushing 7/8"	239-80372-00	239-80372-00	239-80372-00	239-80372-00	239-80372-00
66	Snap-in Bushing 7/8"	239-80406-00	239-80406-00	239-80406-00	239-80406-00	239-80406-00
67	Strain Relief Bushing 1/2"	239-44575-00	239-44575-00	239-44575-00	239-44575-00	239-44575-00

\* Applies to all warranties  
 \*\* Ordering a complete burner rack may increase delivery time. Please order the specific component required for the quickest delivery.  
 \*\*\* No LP version model available.  
 \*\*\*\* No Low Nox versions available over 400K btuh.

▲ Applies when "E" is present in model number (Example: D38T155E3N).

- For serial numbers PRIOR to GB13067706.
- For serial numbers AFTER and including GB13067706.
- For serial numbers PRIOR to HA14465923.
- For serial numbers including and AFTER HA14465923.

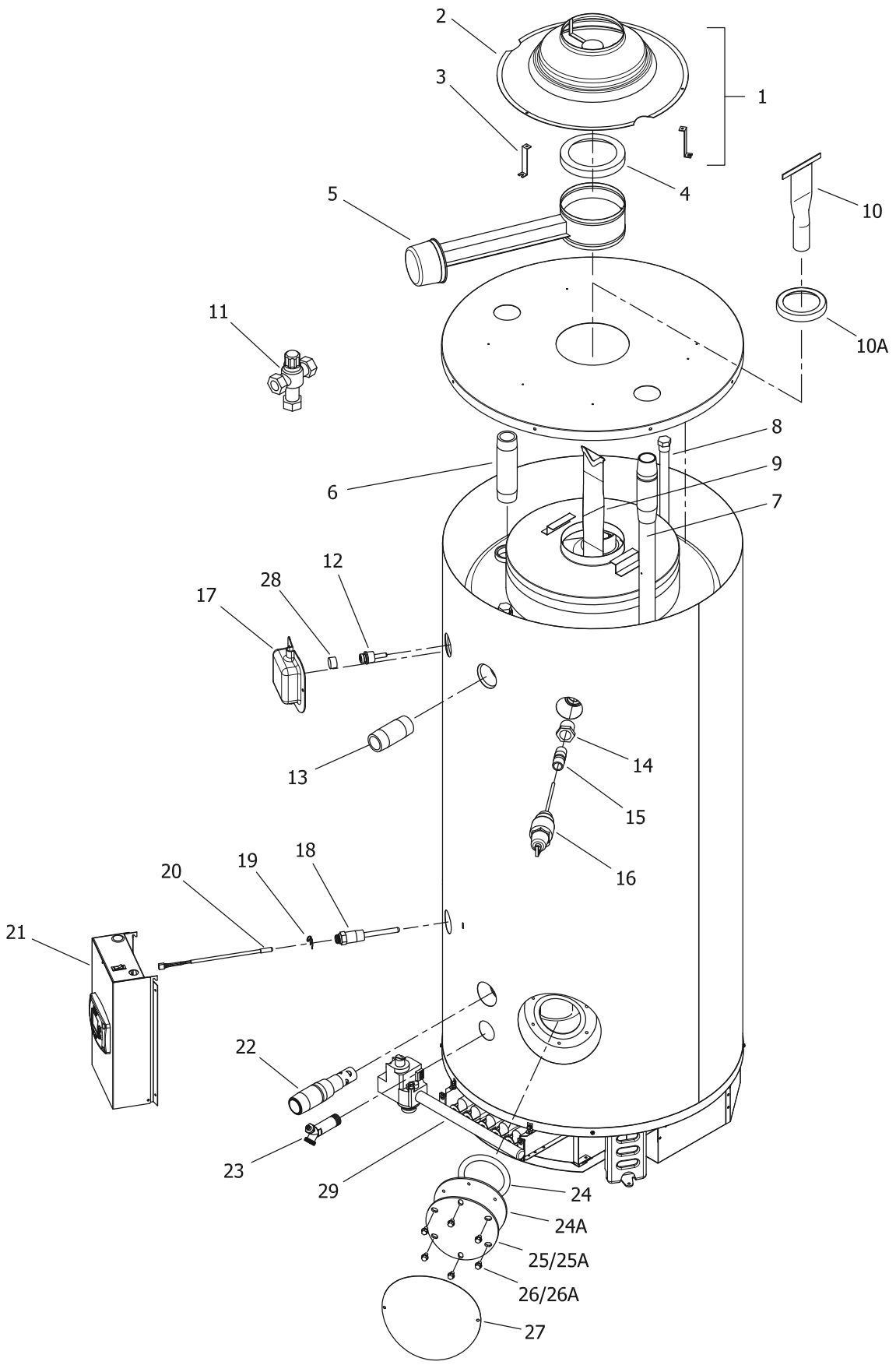

Item	Description	Model	Model	Model	Model	Model
		D80T199(E)*(N,X)	D80T250(E)*(N,X)(A)	D80T425*(N,X)(A)	D80T505*(N,X)(A)	D100L199(E)*(N,X)
1	Draft Diverter Complete with Leg Kit	265-46544-00	265-46544-00	265-46547-00	265-46547-00	265-46549-00
2	Draft Diverter Only	243-81986-00-01	243-81986-00-01	243-82005-02-01	243-82005-02-01	243-81733-00-01
3	Draft Diverter Leg Kit Only	243-43690-02	243-43690-02	243-43690-01	243-43690-01	243-43690-01
4	Flue Damper Reducer	---	---	---	---	239-81811-00
5	Flue Damper Complete	265-42973-00	265-42973-00	265-42975-00	265-42975-00	265-43113-00
6	Hot Water Outlet Nipple (Top)	229-40913-01	229-40913-01	---	---	229-40913-01
7	Cold Water Inlet Diptube (Top)	229-46709-03	229-46709-03	---	---	229-46709-01
8	Plug Type Anode Rod (Magnesium)	224-47782-11 (Qty. 2)	224-47782-11 (Qty. 2)	224-47782-12 (Qty. 3)	224-47782-12 (Qty. 3)	224-47782-06 (Qty. 4)
9	Plug Type Anode Rod (Aluminum)	224-47783-07 (Qty. 2)	224-47783-07 (Qty. 2)	224-47783-08 (Qty. 3)	224-47783-08 (Qty. 3)	224-47783-06 (Qty. 4)
10	Flue Baffle	243-82118-00 (Qty. 8)	243-82117-00 (Qty. 8)	243-39327-00 (Qty. 16)	243-81501-00 (Qty. 16)	243-81735-00 (Qty. 12)
11	Flue Core	---	---	---	---	---
12	Flue Reducer	---	---	---	---	---
13	ASSE Approved Mixing Valve (Optional)	239-43740-02	239-43740-02	239-43740-02	239-43740-02	239-43740-02
14	Upper Thermostat Sensor	239-82033-00	239-82033-00	239-82033-00	239-82033-00	239-82033-00 <sup>2</sup>
15	Hot Water Outlet Nipple (Side)	229-40913-02	229-40913-02	229-40913-02	229-40913-02	229-40913-02
16	1" NPT to 3/4" NPT Reducer Bushing	239-02052-00	---	---	---	239-02052-00
17	3/4" NPT Nipple	229-32762-04	---	---	---	229-32762-02
18	1" NPT Nipple	---	229-32762-19	229-32762-19	229-32762-19	---
19	T&P Valve	230-30246-00	230-33630-04	230-33630-04	230-33630-04	230-30246-00
20	Utility Cover	239-80281-03	239-80281-03	239-80281-03	239-80281-03	239-80281-03 <sup>2</sup>
21	Lower Thermostat Well	233-46558-02	233-46558-02	233-46558-02	233-46558-02	233-46558-01
22	Clip for Lower Thermostat	233-45242-00	233-45242-00	233-45242-00	233-45242-00	233-45242-00
23	Lower Thermostat Sensor	239-46553-01	239-46553-01	239-46553-02	239-46553-02	239-46553-01
24	Control Box Assembly	243-46560-03	243-46560-03	243-46560-02	243-46560-02	243-46614-02
25	Cold Water Inlet Diptube (Side)	229-44731-00	229-44731-00	229-44731-00	229-44731-00	229-44731-00
26	Brass Drain Valve	265-42351-04	265-42351-04	265-42351-04	265-42351-04	265-42351-02
27	Cleanout O-Ring Gasket	205-18427-00	205-18427-00	205-18427-00	205-18427-00	205-18427-00
28	Cleanout Gasket (ASME)	---	205-32942-00	205-32942-00	205-32942-00	---
29	Cleanout Cover	205-18428-00	205-18428-00	205-18428-00	205-18428-00	205-18428-00
30	Cleanout Cover (ASME)	---	205-32941-00	205-32941-00	205-32941-00	---
31	Cleanout Cover Screw	239-82166-00 (Qty. 6)	239-82166-00 (Qty. 6)	239-82166-00 (Qty. 6)	239-82166-00 (Qty. 6)	239-82166-00 (Qty. 6)
32	Cleanout Cover Screw (ASME)	---	239-32970-00 (Qty. 6)	239-32970-00 (Qty. 6)	239-32970-00 (Qty. 6)	---
33	Cleanout Access Cover	243-20299-00	243-20299-00	243-20299-00	243-20299-00	243-20299-00
34	Pipe plug (3/4 NPT)	---	---	---	---	239-11638-00 <sup>1</sup>

\* Applies to all warranties  
 \*\* Ordering a complete burner rack may increase delivery time. Please order the specific component required for the quickest delivery.  
 \*\*\* No LP version model available.  
 \*\*\*\* No Low Nox versions available over 400K btuh.

▲ Applies when "E" is present in model number (Example: D38T155E3N).  
 1 For serial numbers PRIOR to GB13067706.  
 2 For serial numbers AFTER and including GB13067706.  
 3 For serial numbers PRIOR to HA14465923.  
 4 For serial numbers including and AFTER HA14465923

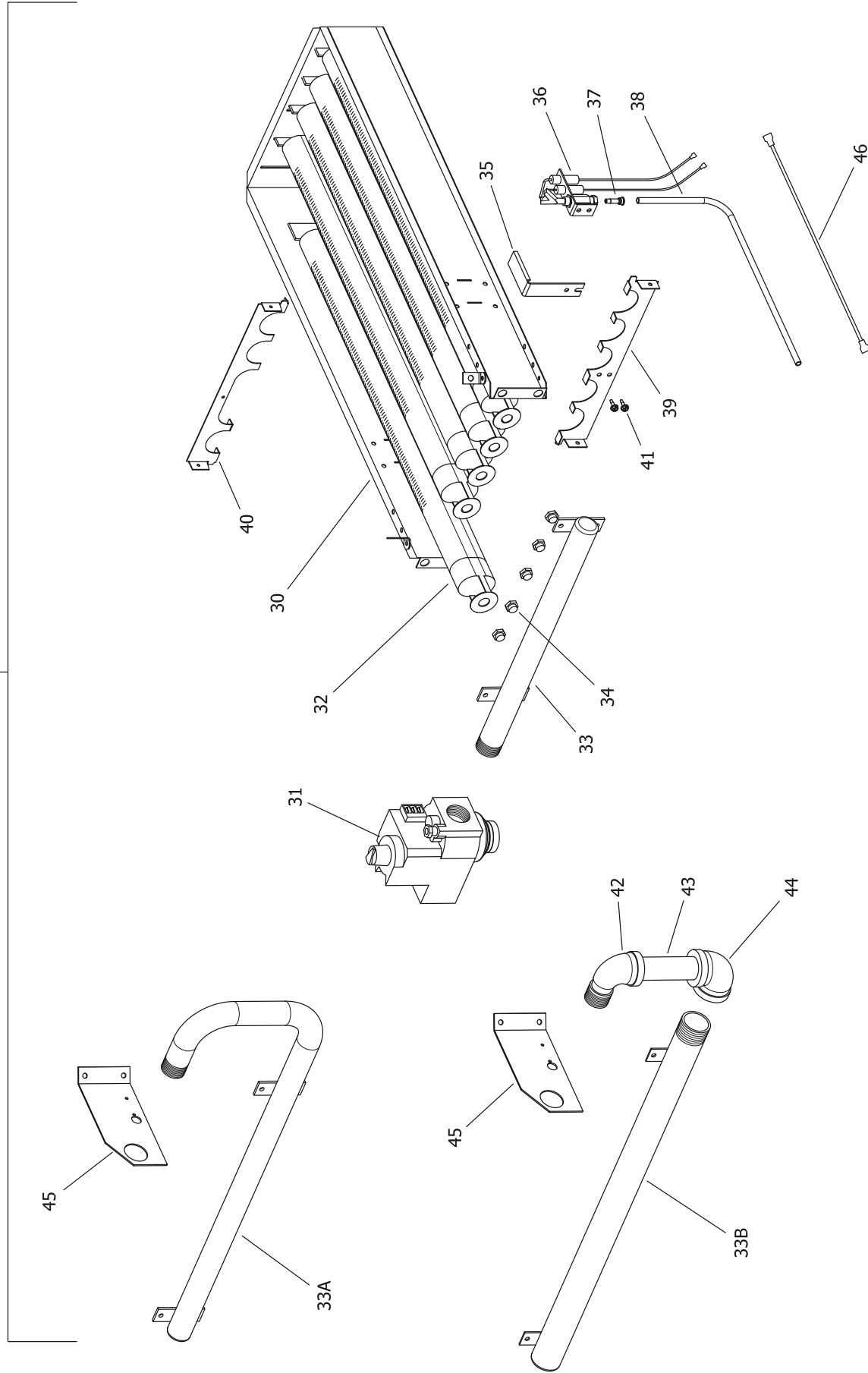



Item	Description	Model	Model	Model	Model	Model
		D80T199(E)*(N,X)	D80T250(E)*(N,X)(A)	D60T425*(N,X)(A)	D80T505*(N,X)(A)	D100L199(E)*(N,X)
29	Burner Rack Complete (Natural Gas) **	243-39205-05	243-81743-03	243-39322-05	243-39322-13	243-81743-01
	Burner Rack Complete (Nat. Gas)(Lo NOX) **▲	243-42563-02	243-42536-02	****	****	243-42536-01
	Burner Rack Complete (LP Gas) **	243-39205-06	243-81743-06	243-39322-06	243-39322-14	243-81743-02
30	Burner Rack Only	233-81969-01	239-81969-02	239-81969-03	239-81969-03	239-81969-02
31	Gas Valve (Natural Gas)	222-80830-02	222-80830-02	222-81608-03	222-81608-03	222-80830-02
	Gas Valve (LP Gas)	222-80831-02	222-80831-02	222-80831-02	222-81608-04	222-80831-02
32	Burner Tube (Standard)	228-39177-00 (Qty. 5)	228-39177-00 (Qty. 7)	228-39177-00 (Qty. 9)	228-39177-00 (Qty. 9)	228-39177-00 (Qty. 7)
	Burner Tube (Lo-NOX) ▲	228-42490-00 (Qty. 5)	228-42490-00 (Qty. 7)	****	****	228-42490-00 (Qty. 7)
	Burner Tube (Stainless Steel)	228-81964-00 (Qty. 5)	228-81964-00 (Qty. 7)	228-81964-00 (Qty. 9)	228-81964-00 (Qty. 9)	228-81964-00 (Qty. 7)
33	Burner Manifold (Nat.gas)	233-39170-00	233-81725-00	---	---	233-81725-00
	Burner Manifold (LP gas)	233-39170-00	233-81725-00	---	---	233-81725-00
33A	Burner Manifold (Nat.gas)	---	---	---	---	---
	Burner Manifold (LP gas)	---	---	---	---	---
	Burner Manifold (LP gas)	---	---	---	---	---
33B	Burner Manifold (Nat.gas)	---	---	233-39171-00	233-39171-00	---
	Burner Manifold (LP gas)	---	---	233-39171-00	233-39171-00	---
34	Main Burner Orifice (Natural Gas) (0ft to 2000ft)	234-06016-35 (Qty. 5)	234-06016-37 (Qty. 7)	234-06016-32 (Qty. 9)	234-06016-30 (Qty. 9)	234-06016-42 (Qty. 7)
	High Altitude (Natural Gas) (2001ft to 5000ft)	234-06016-37 (Qty. 5)	234-06016-40 (Qty. 7)	234-06016-33 (Qty. 9)	234-06016-18 (Qty. 9)	234-06016-43 (Qty. 7)
	High Altitude (Natural Gas) (5001ft to 8000ft)	234-06016-39 (Qty. 5)	234-06016-42 (Qty. 7)	234-06016-36 (Qty. 9)	234-06016-32 (Qty. 9)	234-06016-45 (Qty. 7)
	High Altitude (Natural Gas) (8001ft & above)	234-06016-40 (Qty. 5)	234-06016-42 (Qty. 7)	234-06016-36 (Qty. 9)	234-06016-32 (Qty. 9)	234-06016-45 (Qty. 7)
	Main Burner Orifice (LP Gas) (0ft to 2000ft)	234-06016-49 (Qty. 5)	234-06016-52 (Qty. 7)	234-06016-46 (Qty. 9)	234-06016-45 (Qty. 9)	234-06016-1/16 (Qty. 7)
	High Altitude (LP Gas) (2001ft to 5000ft)	234-06016-50 (Qty. 5)	234-06016-50 (Qty. 7)	234-06016-48 (Qty. 9)	234-06016-46 (Qty. 9)	234-06016-53 (Qty. 7)
	High Altitude (LP Gas) (5001ft to 8000ft)	234-06016-51 (Qty. 5)	234-06016-1/16 (Qty. 7)	234-06016-49 (Qty. 9)	234-06016-47 (Qty. 9)	234-06016-54 (Qty. 7)
	High Altitude (LP Gas) (8001ft & above)	234-06016-52 (Qty. 5)	234-06016-53 (Qty. 7)	234-06016-50 (Qty. 9)	234-06016-48 (Qty. 9)	234-06016-54 (Qty. 7)
35	Pilot Shield	239-41333-00	239-41333-00	239-41333-00	239-41333-00	239-41333-00
36	Pilot Assembly (Natural Gas)	239-41323-01	239-41323-01	239-41323-01	239-41323-01	239-41323-01
	Pilot Assembly (LP Gas)	233-41323-02	233-41323-02	233-41323-02	233-41323-02	233-41323-02
37	Pilot Orifice (Natural Gas)	233-41606-01	233-41606-01	233-41606-01	233-41606-01	233-41606-01
	Pilot Orifice (LP Gas)	233-41606-02	233-41606-02	233-41606-02	233-41606-02	233-41606-02
38	Aluminum Pilot Tube	233-80361-01	233-80361-01	233-80361-01	233-80361-01	233-80361-01
39	Burner Support	239-45180-00	239-45181-00	239-39259-00	239-39259-00	239-45181-00
40	Draft Panel	239-39419-00	239-39420-00	239-39421-00	239-39421-00	239-39420-00
41	Pilot Mounting Screw	239-11706-00 (Qty. 2)	239-11706-00 (Qty. 2)	239-11706-00 (Qty. 2)	239-11706-00 (Qty. 2)	239-11706-00 (Qty. 2)
42	Street Elbow 1" NPT (Nat.)	---	---	239-19636-00	239-19636-00	---
43	Pipe Nipple 1" NPT (Nat.)	---	---	239-81595-00	239-81595-00	---
44	Elbow 1" NPT (Nat.)	---	---	239-19637-00	239-19637-00	---
45	Gas Support Bracket (Nat.)	---	---	239-81816-01	239-81816-01	---
	Gas Support Bracket (LP)	---	---	239-81816-02	239-81816-02	---
46	Ground Wire	239-38951-52	239-38951-52	239-38951-52	239-38951-52	239-38951-52
-	LP to Natural Gas Conversion Kit	265-46033-06	265-46033-07	265-46034-03	265-46034-04	265-46033-08

\* Applies to all warranties  
 \*\* Ordering a complete burner rack may increase delivery time. Please order the specific component required for the quickest delivery.  
 \*\*\* No LP version model available.  
 \*\*\*\* No Low Nox versions available over 400K btuh.

▲ Applies when "E" is present in model number (Example: D38T155E3N).  
 1 For serial numbers PRIOR to GB13067706.  
 2 For serial numbers AFTER and including GB13067706.  
 3 For serial numbers PRIOR to HA14465923.  
 4 For serial numbers including and AFTER HA14465923

21

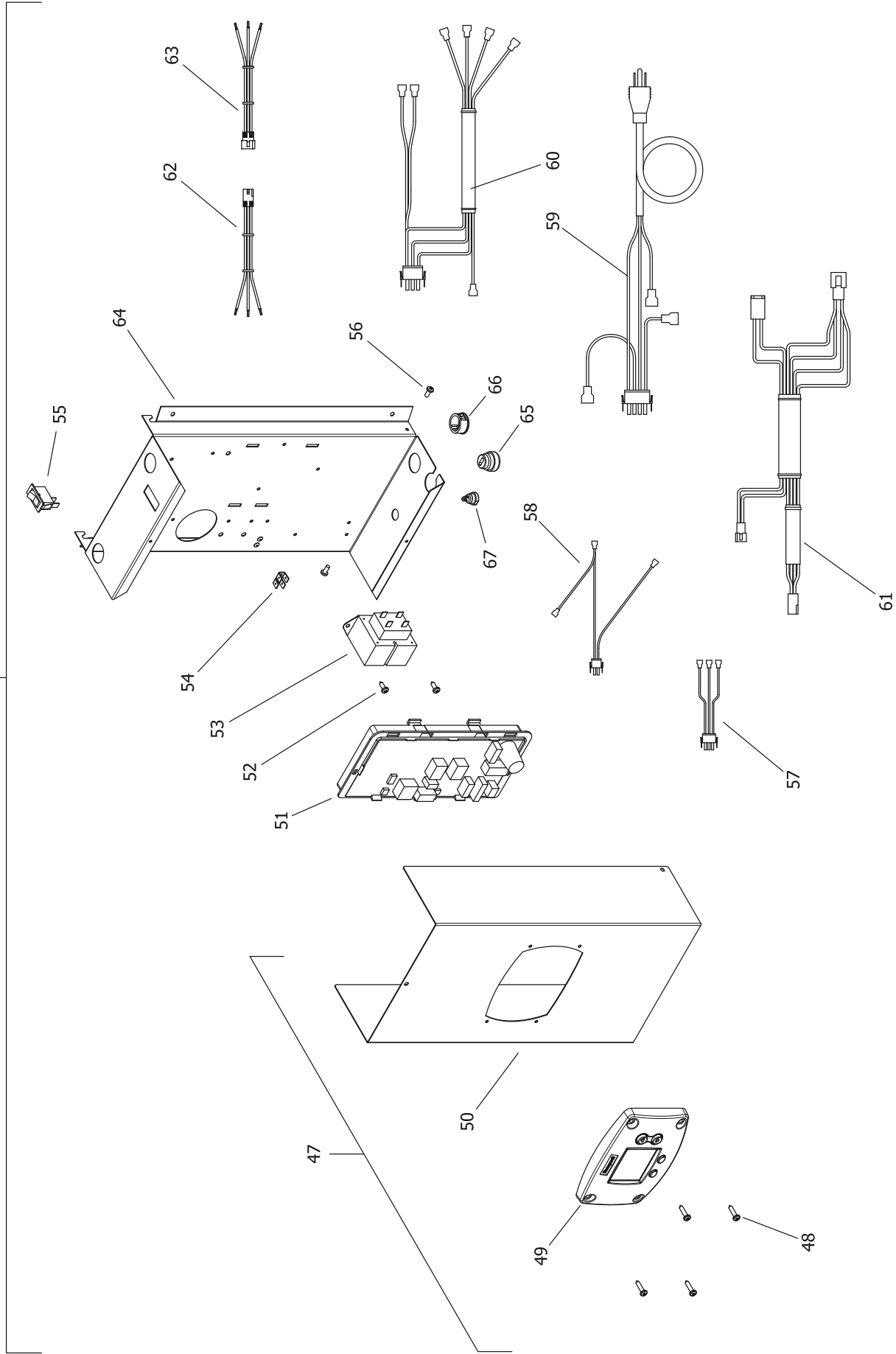

Item	Description	Model	Model	Model	Model	Model
		D80T199(E)*(N,X)	D80T250(E)*(N,X)(A)	D60T425*(N,X)(A)	D80T505*(N,X)(A)	D100L199(E)*(N,X)
21	Control Box Assembly (Dual Sensor)	243-46560-03	243-46560-03	243-46560-02	243-46560-02	243-46560-02 <sup>2</sup>
	Control Box Assembly (Single Sensor)	----	----	----	----	243-46614-02 <sup>1</sup>
47	Control Box Cover Assembly	243-46615-01	243-46615-01	243-46615-01	243-46615-01	243-46615-01
48	Screw #8-18 X 3/4 Pan Head CR	239-43863-00	239-43863-00	239-43863-00	239-43863-00	239-43863-00
49	Honeywell Temperature Control Display	233-46557-00	233-46557-00	233-46557-00	233-46557-00	233-46557-00
50	Control Box Cover	239-46509-00	239-46509-00	239-46509-00	239-46509-00	239-46509-00
51	Integrated Control Board (Dual Sensor)	233-46616-00	233-46616-00	233-46616-00	233-46616-00	233-46616-00 <sup>2</sup>
	Integrated Control Board (Single Sensor)	----	----	----	----	233-47260-00 <sup>1</sup>
52	Screw #8-18 X 1/2 Pan Head CR	239-43736-00	239-43736-00	239-43736-00	239-43736-00	239-43736-00
53	Transformer 110V	233-44072-01	233-44072-01	233-44072-01	233-44072-01	233-44072-01
54	Ground Lug 1/4 x .032	239-80112-00	239-80112-00	239-80112-00	239-80112-00	239-80112-00
55	Power On/Off Switch	239-41566-00	239-41566-00	239-41566-00	239-41566-00	239-41566-00
56	Screw 8/32 X 1/4 Pan Head CR w/adh.	239-46522-00	239-46522-00	239-46522-00	239-46522-00	239-46522-00
57	Primary Transformer Wiring Harness	239-46531-00	239-46531-00	239-46531-00	239-46531-00	239-46531-00
58	Secondary Transformer Wiring Harness	239-46530-00	239-46530-00	239-46530-00	239-46530-00	239-46530-00
59	Power Cord Wiring Harness	239-46533-00	239-46533-00	239-46533-00	239-46533-00	239-46533-00
60	Gas Valve Control Wiring Harness	239-46529-01	239-46529-01	239-46529-02	239-46529-02	239-46529-01
61	Damper Wiring Harness (Dual Sensor)	239-46526-02	239-46526-02	239-46526-02	239-46526-02	239-46526-02 <sup>2</sup>
	Damper Wiring Harness (Single Sensor)	----	----	----	----	239-46527-03 <sup>1</sup>
62	Display Control Wiring Harness	239-46944-00	239-46944-00	239-46944-00	239-46944-00	239-46944-00
63	Display Cover Wiring Harness	239-46617-00	239-46617-00	239-46617-00	239-46617-00	239-46617-00
64	Control Box Panel	239-46508-00	239-46508-00	239-46508-00	239-46508-00	239-46508-00
65	Strain Relief Bushing 7/8"	239-80372-00	239-80372-00	239-80372-00	239-80372-00	239-80372-00
66	Snap-in Bushing 7/8"	239-80406-00	239-80406-00	239-80406-00	239-80406-00	239-80406-00
67	Strain Relief Bushing 1/2"	239-44575-00	239-44575-00	239-44575-00	239-44575-00	239-44575-00

\* Applies to all warranties

\*\* Ordering a complete burner rack may increase delivery time. Please order the specific component required for the quickest delivery.

\*\*\* No LP version model available.

\*\*\*\* No Low Nox versions available over 400K btuh.

▲ Applies when "E" is present in model number (Example: D38T155E3N).

- 1 For serial numbers PRIOR to GB13067706.
- 2 For serial numbers AFTER and including GB13067706.
- 3 For serial numbers PRIOR to HA14465923.
- 4 For serial numbers including and AFTER HA14465923.

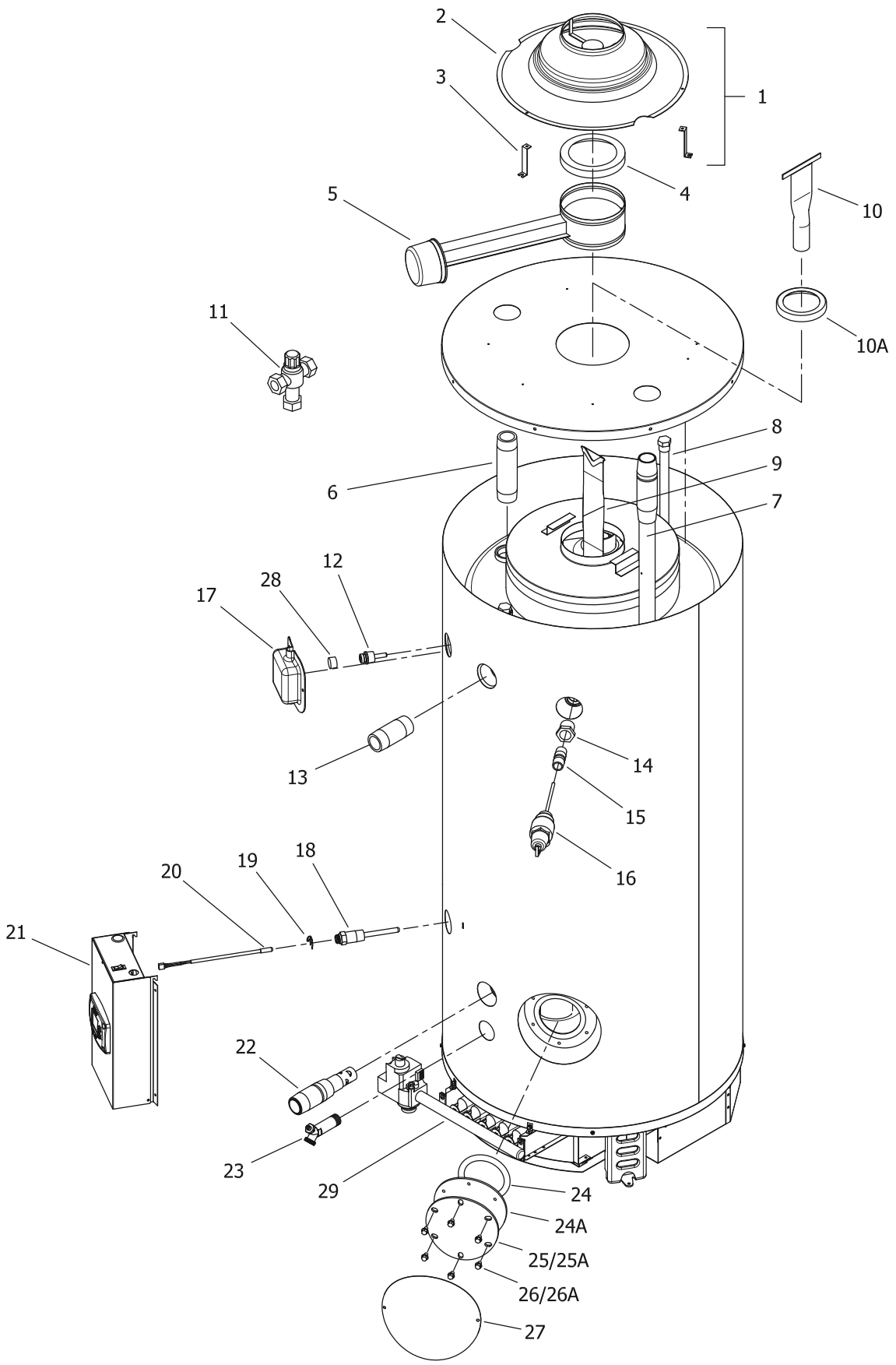

Item	Description	Model D100L250(E)*(N,X)(A)	Model D100L270(E)*(N,A)	Model D100L300(E)*(N,X)(A)	Model D100S199(E)*(N,X)	Model D100S250(E)*(N,X)(A)
1	Draft Diverter Complete with Leg Kit	265-46549-00	265-46549-00	265-46550-00	265-46548-00	265-46548-00
2	Draft Diverter Only	243-81733-00-01	243-81733-00-01	243-81502-00-01	243-81733-00-01	243-81733-00-01
3	Draft Diverter Leg Kit Only	243-43690-01	243-43690-01	243-43690-06	243-43690-09	243-43690-09
4	Flue Damper Reducer	239-81811-00	239-81811-00	---	239-81811-00	239-81811-00
5	Flue Damper Complete	265-43113-00	265-43113-00	265-42974-00	265-43113-00	265-43113-00
6	Hot Water Outlet Nipple (Top)	229-40913-01	229-40913-01	229-40913-01	229-40913-01	229-40913-01
7	Cold Water Inlet Diptube (Top)	229-46709-01	229-46709-01	229-46709-01	229-46709-01	229-46709-01
8	Plug Type Anode Rod (Magnesium)	224-47782-06 (Qty. 4)	224-47782-06 (Qty. 4)	224-47782-06 (Qty. 4)	224-47782-06 (Qty. 4)	224-47782-06 (Qty. 4)
9	Plug Type Anode Rod (Aluminum)	224-47783-06 (Qty. 4)	224-47783-06 (Qty. 4)	224-47783-06 (Qty. 4)	224-47783-06 (Qty. 4)	224-47783-06 (Qty. 4)
9	Flue Baffle	243-39392-00 (Qty. 12)	243-81796-00 (Qty. 12)	243-81737-00 (Qty. 12)	243-81735-00 (Qty. 9)	243-81566-00 (Qty. 9)
10	Flue Core	---	---	---	---	---
10A	Flue Reducer	---	---	---	---	---
11	ASSE Approved Mixing Valve (Optional)	239-43740-02	239-43740-02	239-43740-02	239-43740-02	239-43740-02
12	Upper Thermostat Sensor	239-82033-00 <sup>2</sup>	239-82033-00 <sup>2</sup>	239-82033-00 <sup>2</sup>	239-82033-00 <sup>4</sup>	239-82033-00 <sup>4</sup>
13	Hot Water Outlet Nipple (Side)	229-40913-02	229-40913-02	229-40913-02	229-40913-02	229-40913-02
14	1" NPT to 3/4" NPT Reducer Bushing	---	---	---	---	---
15	3/4" NPT Nipple	---	---	---	---	---
15	1" NPT Nipple	239-80982-00	239-80982-00	239-80982-00	---	239-80982-00
16	T&P Valve	230-33630-04	230-33630-04	230-33630-04	230-33630-04	230-33630-04
17	Utility Cover	239-80281-03 <sup>2</sup>	239-80281-03 <sup>2</sup>	239-80281-03 <sup>2</sup>	239-80281-03 <sup>4</sup>	239-80281-03 <sup>4</sup>
18	Lower Thermostat Well	233-46558-01	233-46558-01	233-46558-01	233-46558-01	233-46558-01
19	Clip for Lower Thermostat	233-45242-00	233-45242-00	233-45242-00	233-45242-00	233-45242-00
20	Lower Thermostat Sensor	239-46553-01	239-46553-01	239-46553-01	239-46553-01	239-46553-01
21	Control Box Assembly	243-46614-02	243-46614-02	243-46614-02	243-46614-03	243-46614-03
22	Cold Water Inlet Diptube (Side)	229-44731-00	229-44731-00	229-44731-00	229-44731-00	229-44731-00
23	Brass Drain Valve	265-42351-02	265-42351-02	265-42351-02	265-42351-02	265-42351-02
24	Cleanout O-Ring Gasket	205-18427-00	205-18427-00	205-18427-00	205-18427-00	205-18427-00
24A	Cleanout Gasket (ASME)	205-32942-00	205-32942-00	205-32942-00	---	205-32942-00
25	Cleanout Cover	205-18428-00	205-18428-00	205-18428-00	205-18428-00	205-18428-00
25A	Cleanout Cover (ASME)	205-32941-00	205-32941-00	205-32941-00	---	205-32941-00
26	Cleanout Cover Screw	239-82166-00 (Qty. 6)	239-82166-00 (Qty. 6)	239-82166-00 (Qty. 6)	239-82166-00 (Qty. 6)	239-82166-00 (Qty. 6)
26A	Cleanout Cover Screw (ASME)	239-32970-00 (Qty. 6)	239-32970-00 (Qty. 6)	239-32970-00 (Qty. 6)	---	239-32970-00 (Qty. 6)
27	Cleanout Access Cover	243-20299-00	243-20299-00	243-20299-00	243-20299-00	243-20299-00
28	Pipe plug (3/4 NPT)	239-11638-00 <sup>1</sup>	239-11638-00 <sup>1</sup>	239-11638-00 <sup>1</sup>	239-11638-00	239-11638-00

\* Applies to all warranties  
 \*\* Ordering a complete burner rack may increase delivery time. Please order the specific component required for the quickest delivery.  
 \*\*\* No LP version model available.  
 \*\*\*\* No Low Nox versions available over 400K btuh.

▲ Applies when "E" is present in model number (Example: D38T155E3N).  
 1 For serial numbers PRIOR to GB13067706.  
 2 For serial numbers AFTER and including GB13067706.  
 3 For serial numbers PRIOR to HA14465923.  
 4 For serial numbers including and AFTER HA14465923

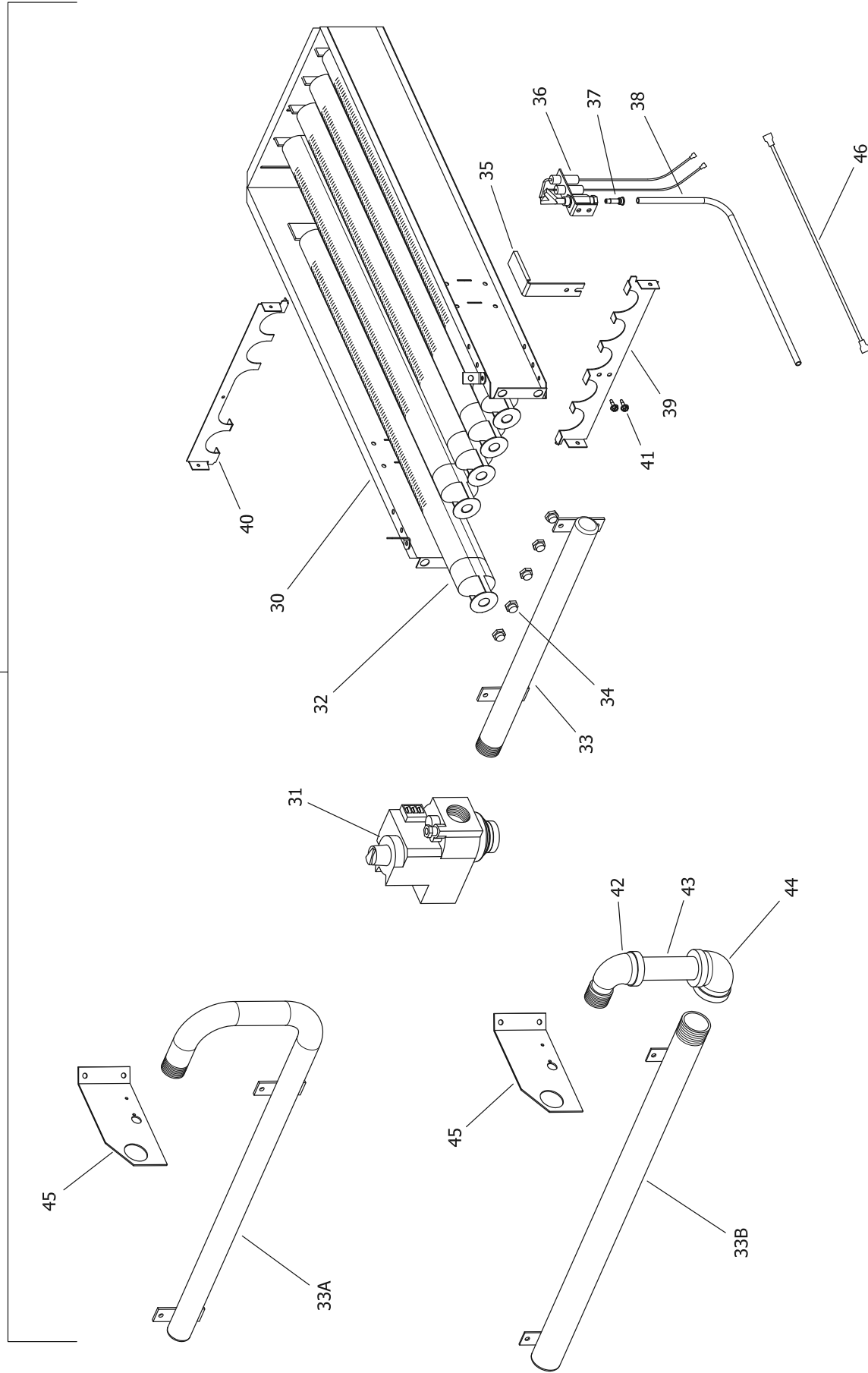

Item	Description	Model D100L250(E)*(N,X)(A)	Model D100L270(E)*(N,A)	Model D100L300(E)*(N,X)(A)	Model D100S199(E)*(N,X)	Model D100S250(E)*(N,X)(A)
29	Burner Rack Complete (Natural Gas) **	243-81743-03	243-81743-05	243-81743-07	243-39205-05	243-39205-09
	Burner Rack Complete (Nat. Gas)(Lo NOX) **▲	243-42536-02	243-42536-03	243-42536-04	243-42563-02	243-42563-04
	Burner Rack Complete (LP Gas) **	243-81743-06	---	243-81743-08	243-39205-06	243-39205-10
30	Burner Rack Only	239-81969-02	239-81969-02	239-81969-02	233-81969-01	233-81969-01
31	Gas Valve (Natural Gas)	222-80830-02	222-80830-02	222-80830-02	222-80830-02	222-80830-02
	Gas Valve (LP Gas)	222-80831-02	222-80831-02	222-80831-02	222-80831-02	222-80831-02
32	Burner Tube (Standard)	228-39177-00 (Qty. 7)	228-39177-00 (Qty. 7)	228-39177-00 (Qty. 7)	228-39177-00 (Qty. 5)	228-39177-00 (Qty. 5)
	Burner Tube (Lo-NOX) ▲	228-42490-00 (Qty. 7)	228-42490-00 (Qty. 7)	228-42490-00 (Qty. 7)	228-42490-00 (Qty. 5)	228-42490-00 (Qty. 5)
	Burner Tube (Stainless Steel)	228-81964-00 (Qty. 7)	228-81964-00 (Qty. 7)	228-81964-00 (Qty. 7)	228-81964-00 (Qty. 5)	228-81964-00 (Qty. 5)
33	Burner Manifold (Nat.gas)	233-81725-00	233-81725-00	233-81725-00	233-39170-00	233-39170-00
	Burner Manifold (LP gas)	233-81725-00	233-81725-00	233-81725-00	233-39170-00	233-39170-00
33A	Burner Manifold (Nat.gas)	---	---	---	---	---
	Burner Manifold (LP gas)	---	---	---	---	---
33B	Burner Manifold (Nat.gas)	---	---	---	---	---
34	Main Burner Orifice (Natural Gas) (0ft to 2000ft)	234-06016-37 (Qty. 7)	234-06016-36 (Qty. 7)	234-06016-33 (Qty. 7)	234-06016-35 (Qty. 5)	234-06016-31 (Qty. 5)
	High Altitude (Natural Gas) (2001ft to 5000ft)	234-06016-40 (Qty. 7)	234-06016-38 (Qty. 7)	234-06016-36 (Qty. 7)	234-06016-37 (Qty. 5)	234-06016-32 (Qty. 5)
	High Altitude (Natural Gas) (5001ft to 8000ft)	234-06016-42 (Qty. 7)	234-06016-73 (Qty. 7)	234-06016-37 (Qty. 7)	234-06016-39 (Qty. 5)	234-06016-34 (Qty. 5)
	High Altitude (Natural Gas) (8001ft & above)	234-06016-42 (Qty. 7)	234-06016-73 (Qty. 7)	234-06016-38 (Qty. 7)	234-06016-40 (Qty. 5)	234-06016-35 (Qty. 5)
	Main Burner Orifice (LP Gas) (0ft to 2000ft)	234-06016-50 (Qty. 7)	***	234-06016-48 (Qty. 7)	234-06016-49 (Qty. 5)	234-06016-46 (Qty. 5)
	High Altitude (LP Gas) (2001ft to 5000ft)	234-06016-52 (Qty. 7)	***	234-06016-50 (Qty. 7)	234-06016-50 (Qty. 5)	234-06016-48 (Qty. 5)
	High Altitude (LP Gas) (5001ft to 8000ft)	234-06016-116 (Qty. 7)	***	234-06016-51 (Qty. 7)	234-06016-51 (Qty. 5)	234-06016-49 (Qty. 5)
	High Altitude (LP Gas) (8001ft & above)	234-06016-53 (Qty. 7)	***	234-06016-51 (Qty. 7)	234-06016-52 (Qty. 5)	234-06016-50 (Qty. 5)
35	Pilot Shield	239-41333-00	239-41333-00	239-41333-00	239-41333-00	239-41333-00
36	Pilot Assembly (Natural Gas)	239-41323-01	239-41323-01	239-41323-01	239-41323-01	239-41323-01
	Pilot Assembly (LP Gas)	233-41323-02	***	233-41323-02	233-41323-02	233-41323-02
37	Pilot Orifice (Natural Gas)	233-41606-01	233-41606-01	233-41606-01	233-41606-01	233-41606-01
	Pilot Orifice (LP Gas)	233-41606-02	***	233-41606-02	233-41606-02	233-41606-02
38	Aluminum Pilot Tube	233-80361-01	233-80361-01	233-80361-01	233-80361-01	233-80361-01
39	Burner Support	239-45181-00	239-45181-00	239-45181-00	239-45181-00	239-45181-00
40	Draft Panel	239-39420-00	239-39420-00	239-39420-00	239-39419-00	239-39419-00
41	Pilot Mounting Screw	239-11706-00 (Qty. 2)	239-11706-00 (Qty. 2)	239-11706-00 (Qty. 2)	239-11706-00 (Qty. 2)	239-11706-00 (Qty. 2)
42	Street Elbow 1" NPT (Nat.)	---	---	---	---	---
43	Pipe Nipple 1" NPT (Nat.)	---	---	---	---	---
44	Elbow 1" NPT (Nat.)	---	---	---	---	---
45	Gas Support Bracket (Nat.)	---	---	---	---	---
	Gas Support Bracket (LP)	---	---	---	---	---
46	Ground Wire	239-38951-52	239-38951-52	239-38951-52	239-38951-52	239-38951-52
-	LP to Natural Gas Conversion Kit	265-46033-07	---	265-46033-09	265-46033-06	265-46033-10

\* Applies to all warranties  
 \*\* Ordering a complete burner rack may increase delivery time. Please order the specific component required for the quickest delivery.  
 \*\*\* No LP version model available.  
 \*\*\*\* No Low Nox versions available over 400K btuh.  
 ▲ Applies when "E" is present in model number (Example: D38T155E3N).  
 1 For serial numbers PRIOR to GB13067706.  
 2 For serial numbers AFTER and including GB13067706.  
 3 For serial numbers PRIOR to HA14465923.  
 4 For serial numbers including and AFTER HA14465923

21

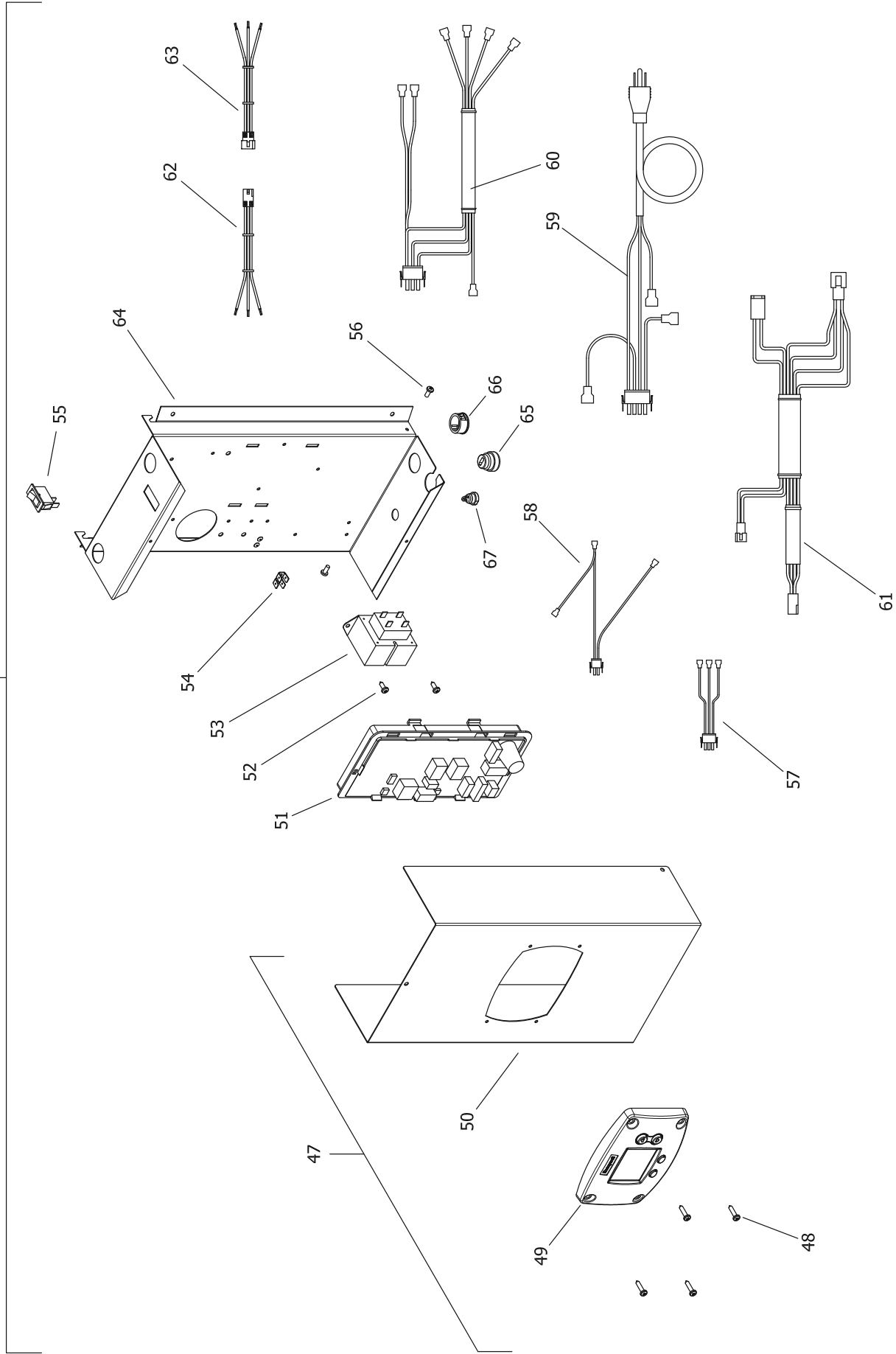



Item	Description	Model D100L250(E)*(N,X)(A)	Model D100L270(E)*(N,A)	Model D100L300(E)*(N,X)(A)	Model D100S199(E)*(N,X)	Model D100S250(E)*(N,X)(A)
21	Control Box Assembly (Dual Sensor)	243-46560-03 <sup>2</sup>	243-46560-03 <sup>2</sup>	243-46560-03 <sup>2</sup>	243-46560-03 <sup>4</sup>	243-46560-03 <sup>4</sup>
	Control Box Assembly (Single Sensor)	243-46614-02 <sup>1</sup>	243-46614-02 <sup>1</sup>	243-46614-02 <sup>1</sup>	243-46614-03 <sup>3</sup>	243-46614-03 <sup>3</sup>
47	Control Box Cover Assembly	243-46615-01	243-46615-01	243-46615-01	243-46615-01	243-46615-01
48	Screw #8-18 X 3/4 Pan Head CR	239-43863-00	239-43863-00	239-43863-00	239-43863-00	239-43863-00
49	Honeywell Temperature Control Display	233-46557-00	233-46557-00	233-46557-00	233-46557-00	233-46557-00
50	Control Box Cover	239-46509-00	239-46509-00	239-46509-00	239-46509-00	239-46509-00
51	Integrated Control Board (Dual Sensor)	233-46616-00 <sup>2</sup>	233-46616-00 <sup>2</sup>	233-46616-00 <sup>2</sup>	233-46616-00 <sup>4</sup>	233-46616-00 <sup>4</sup>
	Integrated Control Board (Single Sensor)	233-47260-00 <sup>1</sup>	233-47260-00 <sup>1</sup>	233-47260-00 <sup>1</sup>	233-47260-00 <sup>3</sup>	233-47260-00 <sup>3</sup>
52	Screw #8-18 X 1/2 Pan Head CR	239-43736-00	239-43736-00	239-43736-00	239-43736-00	239-43736-00
53	Transformer 110V	233-44072-01	233-44072-01	233-44072-01	233-44072-01	233-44072-01
54	Ground Lug 1/4 x .032	239-80112-00	239-80112-00	239-80112-00	239-80112-00	239-80112-00
55	Power On/Off Switch	239-41566-00	239-41566-00	239-41566-00	239-41566-00	239-41566-00
56	Screw 8/32 X 1/4 Pan Head CR w/adh.	239-46522-00	239-46522-00	239-46522-00	239-46522-00	239-46522-00
57	Primary Transformer Wiring Harness	239-46531-00	239-46531-00	239-46531-00	239-46531-00	239-46531-00
58	Secondary Transformer Wiring Harness	239-46530-00	239-46530-00	239-46530-00	239-46530-00	239-46530-00
59	Power Cord Wiring Harness	239-46533-00	239-46533-00	239-46533-00	239-46533-00	239-46533-00
60	Gas Valve Control Wiring Harness	239-46529-01	239-46529-01	239-46529-01	239-46529-02	239-46529-02
61	Damper Wiring Harness (Dual Sensor)	239-46526-02 <sup>2</sup>	239-46526-02 <sup>2</sup>	239-46526-02 <sup>2</sup>	239-46526-02 <sup>4</sup>	239-46526-02 <sup>4</sup>
	Damper Wiring Harness (Single Sensor)	239-46527-03 <sup>1</sup>	239-46527-03 <sup>1</sup>	239-46527-03 <sup>1</sup>	239-46527-03 <sup>3</sup>	239-46527-03 <sup>3</sup>
62	Display Control Wiring Harness	239-46944-00	239-46944-00	239-46944-00	239-46944-00	239-46944-00
63	Display Cover Wiring Harness	239-46617-00	239-46617-00	239-46617-00	239-46617-00	239-46617-00
64	Control Box Panel	239-46508-00	239-46508-00	239-46508-00	239-46508-00	239-46508-00
65	Strain Relief Bushing 7/8"	239-80372-00	239-80372-00	239-80372-00	239-80372-00	239-80372-00
66	Snap-in Bushing 7/8"	239-80406-00	239-80406-00	239-80406-00	239-80406-00	239-80406-00
67	Strain Relief Bushing 1/2"	239-44575-00	239-44575-00	239-44575-00	239-44575-00	239-44575-00

\* Applies to all warranties  
 \*\* Ordering a complete burner rack may increase delivery time. Please order the specific component required for the quickest delivery.  
 \*\*\* No LP version model available.  
 \*\*\*\* No Low Nox versions available over 400K btuh.

▲ Applies when "E" is present in model number (Example: D38T155E3N).  
 1 For serial numbers PRIOR to GB13067706.  
 2 For serial numbers AFTER and including GB13067706.  
 3 For serial numbers PRIOR to HA14465923.  
 4 For serial numbers including and AFTER HA14465923

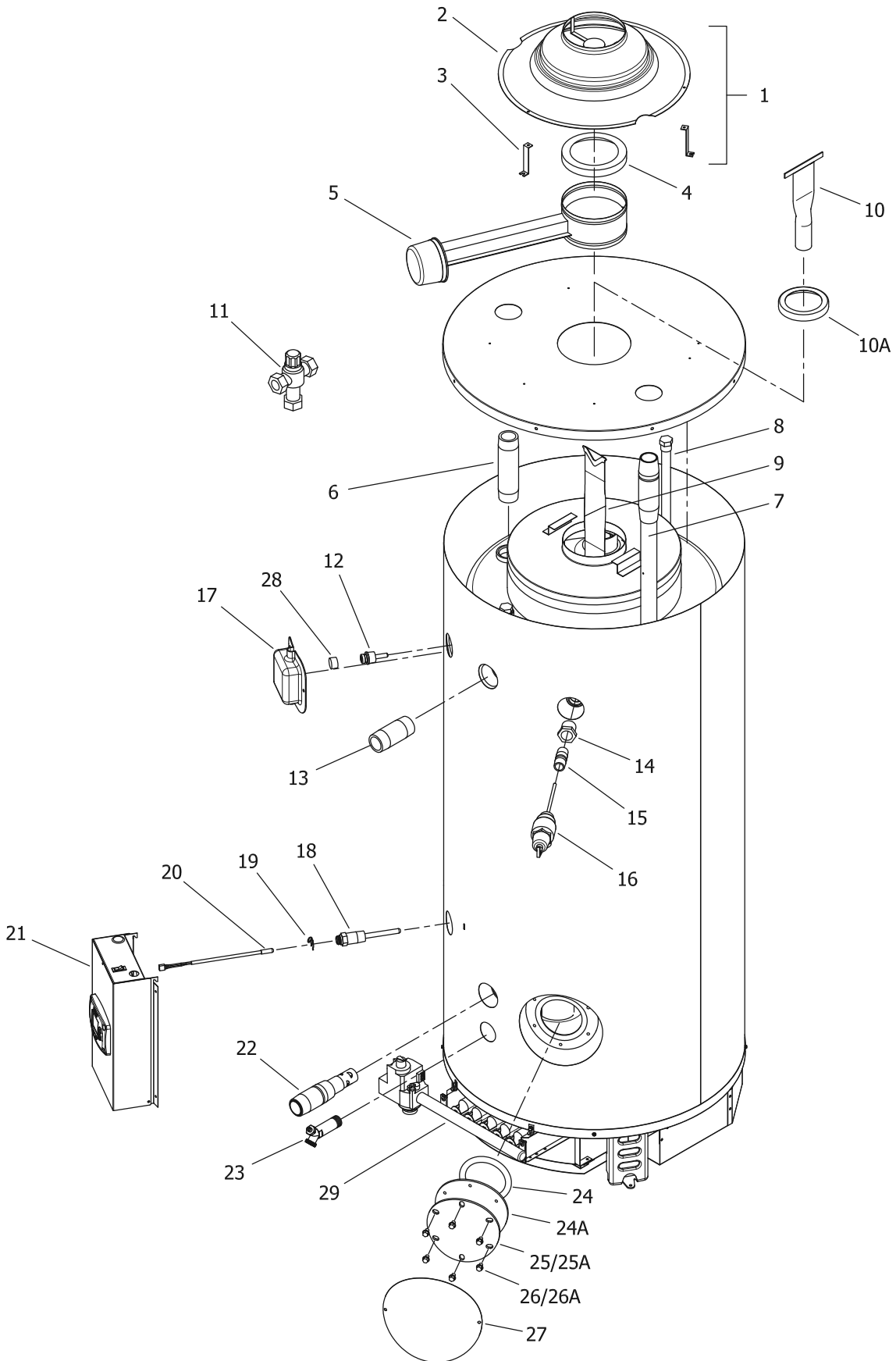

Item	Description	Model	
		D100T199(E)*(N,X)	D100T250(E)*(N,X)(A)
1	Draft Diverter Complete with Leg Kit	265-46544-00	265-46544-00
2	Draft Diverter Only	243-81986-00-01	243-81986-00-01
3	Draft Diverter Leg Kit Only	243-43690-02	243-43690-02
4	Flue Damper Reducer	---	---
5	Flue Damper Complete	265-42973-00	265-42973-00
6	Hot Water Outlet Nipple (Top)	229-40913-01	229-40913-01
7	Cold Water Inlet Diptube (Top)	229-46709-02	229-46709-02
8	Plug Type Anode Rod (Magnesium)	224-47782-12 (Qty. 2)	224-47782-12 (Qty. 2)
9	Plug Type Anode Rod (Aluminum)	224-47783-08 (Qty. 2)	224-47783-08 (Qty. 2)
10	Flue Baffle	243-39392-00 (Qty. 8)	243-39341-00 (Qty. 8)
10A	Flue Core	---	---
11	Flue Reducer	---	---
11A	ASSE Approved Mixing Valve (Optional)	239-43740-02	239-43740-02
12	Upper Thermostat Sensor	239-82033-00	239-82033-00
13	Hot Water Outlet Nipple (Side)	229-40913-02	229-40913-02
14	1" NPT to 3/4" NPT Reducer Bushing	239-02052-00	---
15	3/4" NPT Nipple	229-32762-04	---
16	1" NPT Nipple	---	229-32762-19
17	T&P Valve	230-30246-00	230-33630-04
18	Utility Cover	239-80281-03	239-80281-03
19	Lower Thermostat Well	233-46558-02	233-46558-02
20	Clip for Lower Thermostat	233-45242-00	233-45242-00
21	Lower Thermostat Sensor	239-46553-01	239-46553-01
22	Control Box Assembly	243-46560-05	243-46560-05
23	Cold Water Inlet Diptube (Side)	229-44731-00	229-44731-00
24	Brass Drain Valve	265-42351-04	265-42351-04
24A	Cleanout O-Ring Gasket (ASME)	205-18427-00	205-18427-00
25	Cleanout Cover	---	205-32942-00
25A	Cleanout Cover (ASME)	205-18428-00	205-18428-00
26	Cleanout Cover Screw	---	205-32941-00
26A	Cleanout Cover Screw (ASME)	239-82166-00 (Qty. 6)	239-82166-00 (Qty. 6)
27	Cleanout Access Cover	---	239-32970-00 (Qty. 6)
28	Pipe plug (3/4 NPT)	243-20299-00	243-20299-00

\* Applies to all warranties  
 \*\* Ordering a complete burner rack may increase delivery time. Please order the specific component required for the quickest delivery.  
 \*\*\* No LP version model available.  
 \*\*\*\* No Low Nox versions available over 400K btuh.

▲ Applies when "E" is present in model number (Example: D38T155E3N).  
 1 For serial numbers PRIOR to GB13067706.  
 2 For serial numbers AFTER and including GB13067706.  
 3 For serial numbers PRIOR to HA14465923.  
 4 For serial numbers including and AFTER HA14465923

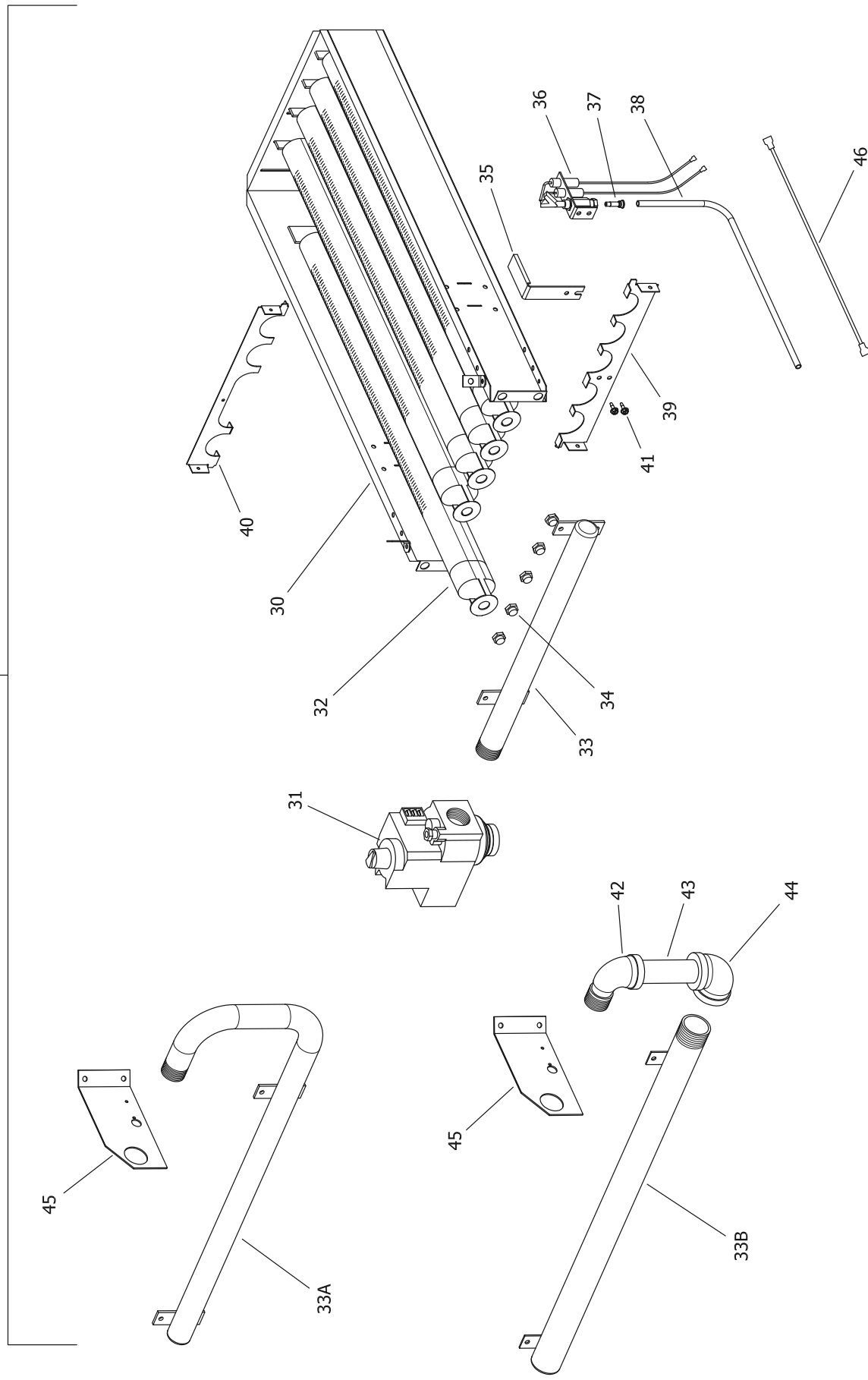

Item	Description	Model	
		D100T199(E)*(N,X)	D100T250(E)*(N,X)(A)
29	Burner Rack Complete (Natural Gas) **	243-39205-05	243-39205-09
	Burner Rack Complete (Nat. Gas)(Lo NOX) **▲	243-42563-02	243-42563-04
	Burner Rack Complete (LP Gas) **	243-39205-06	243-39205-10
30	Burner Rack Only	233-81969-01	233-81969-01
31	Gas Valve (Natural Gas)	222-80830-02	222-80830-02
	Gas Valve (LP Gas)	222-80831-02	222-80831-02
32	Burner Tube (Standard)	228-39177-00 (Qty. 5)	228-39177-00 (Qty. 5)
	Burner Tube (Lo-NOX) ▲	228-42490-00 (Qty. 5)	228-42490-00 (Qty. 5)
	Burner Tube (Stainless Steel)	228-81964-00 (Qty. 5)	228-81964-00 (Qty. 5)
33	Burner Manifold (Nat.gas)	233-39170-00	233-39170-00
	Burner Manifold (LP gas)	233-39170-00	233-39170-00
33A	Burner Manifold (Nat.gas)	----	----
	Burner Manifold (LP gas)	----	----
33B	Burner Manifold (Nat.gas)	----	----
34	Main Burner Orifice (Natural Gas) (0ft to 2000ft)	234-06016-35 (Qty. 5)	234-06016-31 (Qty. 5)
	High Altitude (Natural Gas) (2001ft to 5000ft)	234-06016-37 (Qty. 5)	234-06016-32 (Qty. 5)
	High Altitude (Natural Gas) (5001ft to 8000ft)	234-06016-39 (Qty. 5)	234-06016-34 (Qty. 5)
	High Altitude (Natural Gas) (8001ft & above)	234-06016-40 (Qty. 5)	234-06016-35 (Qty. 5)
	Main Burner Orifice (LP Gas) (0ft to 2000ft)	234-06016-49 (Qty. 5)	234-06016-46 (Qty. 5)
	High Altitude (LP Gas) (2001ft to 5000ft)	234-06016-50 (Qty. 5)	234-06016-48 (Qty. 5)
	High Altitude (LP Gas) (5001ft to 8000ft)	234-06016-51 (Qty. 5)	234-06016-49 (Qty. 5)
	High Altitude (LP Gas) (8001ft & above)	234-06016-52 (Qty. 5)	234-06016-50 (Qty. 5)
35	Pilot Shield	239-41333-00	239-41333-00
36	Pilot Assembly (Natural Gas)	239-41323-01	239-41323-01
	Pilot Assembly (LP Gas)	233-41323-02	233-41323-02
37	Pilot Orifice (Natural Gas)	233-41606-01	233-41606-01
	Pilot Orifice (LP Gas)	233-41606-02	233-41606-02
38	Aluminum Pilot Tube	233-80361-01	233-80361-01
39	Burner Support	239-45180-00	239-45180-00
40	Draft Panel	239-39419-00	239-39419-00
41	Pilot Mounting Screw	239-11706-00 (Qty. 2)	239-11706-00 (Qty. 2)
42	Street Elbow 1" NPT (Nat.)	----	----
43	Pipe Nipple 1" NPT (Nat.)	----	----
44	Elbow 1" NPT (Nat.)	----	----
45	Gas Support Bracket (Nat.)	----	----
	Gas Support Bracket (LP)	----	----
46	Ground Wire	239-38951-52	239-38951-52
-	LP to Natural Gas Conversion Kit	265-46033-06	265-46033-10

\* Applies to all warranties  
 \*\* Ordering a complete burner rack may increase delivery time. Please order the specific component required for the quickest delivery.  
 \*\*\* No LP version model available.  
 \*\*\*\* No Low Nox versions available over 400K btuh.

▲ Applies when "E" is present in model number (Example: D38T155E3N).  
 1 For serial numbers PRIOR to GB13067706.  
 2 For serial numbers AFTER and including GB13067706.  
 3 For serial numbers PRIOR to HA14465923.  
 4 For serial numbers including and AFTER HA14465923

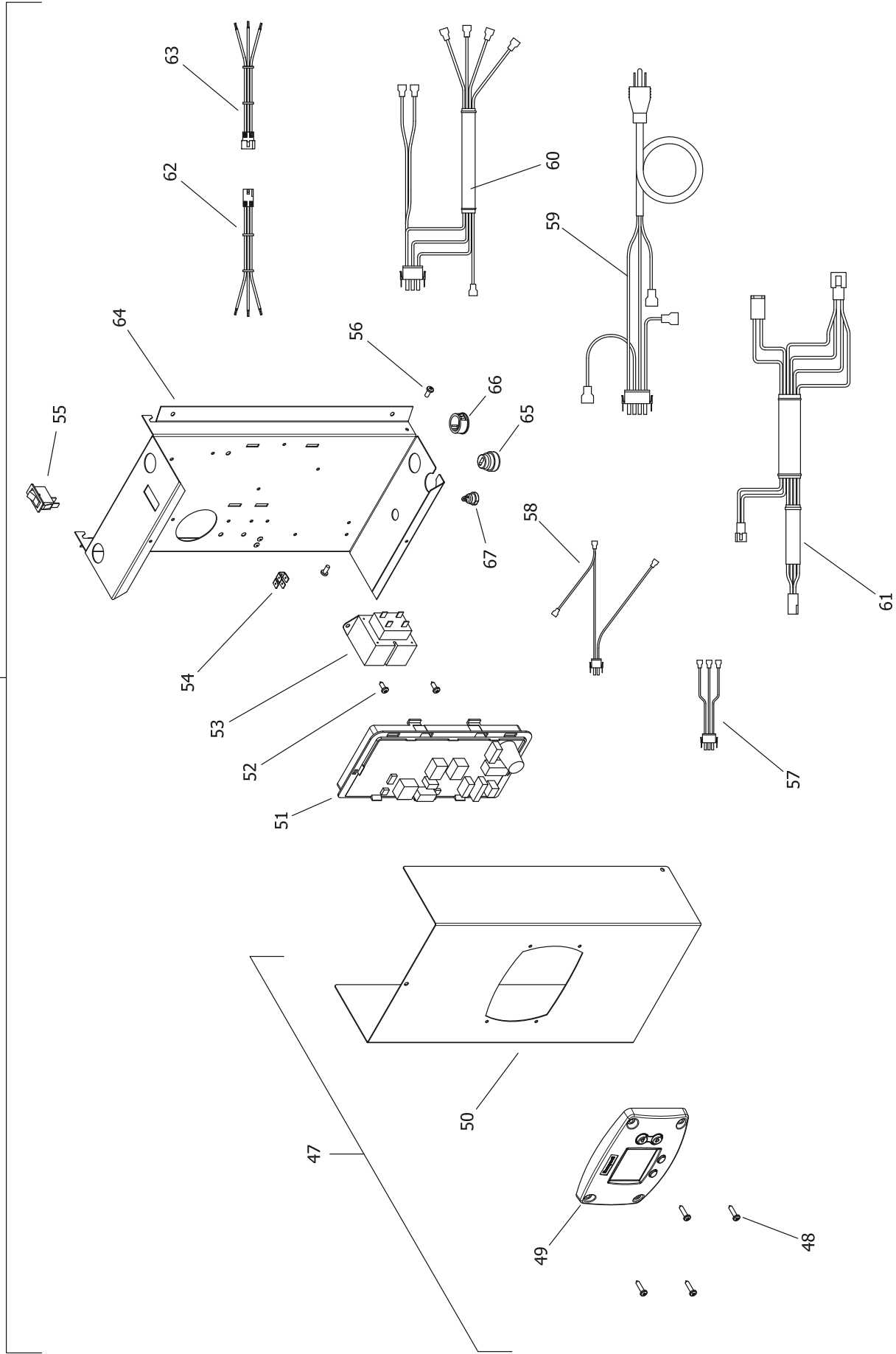

Item	Description	Model	
		D100T199(E)*(N,X)	D100T250(E)*(N,X)(A)
21	Control Box Assembly (Dual Sensor)	243-46560-05	243-46560-05
	Control Box Assembly (Single Sensor)	----	----
47	Control Box Cover Assembly	243-46615-01	243-46615-01
48	Screw #8-18 X 3/4 Pan Head CR	239-43863-00	239-43863-00
49	Honeywell Temperature Control Display	233-46557-00	233-46557-00
50	Control Box Cover	239-46509-00	239-46509-00
51	Integrated Control Board (Dual Sensor)	233-46616-00	233-46616-00
	Integrated Control Board (Single Sensor)	----	----
52	Screw #8-18 X 1/2 Pan Head CR	239-43736-00	239-43736-00
53	Transformer 110V	233-44072-01	233-44072-01
54	Ground Lug 1/4 x .032	239-80112-00	239-80112-00
55	Power On/Off Switch	239-41566-00	239-41566-00
56	Screw 8/32 X 1/4 Pan Head CR w/adh.	239-46522-00	239-46522-00
57	Primary Transformer Wiring Harness	239-46531-00	239-46531-00
58	Secondary Transformer Wiring Harness	239-46530-00	239-46530-00
59	Power Cord Wiring Harness	239-46533-00	239-46533-00
60	Gas Valve Control Wiring Harness	239-46529-01	239-46529-01
61	Damper Wiring Harness (Dual Sensor)	239-46526-03	239-46526-03
	Damper Wiring Harness (Single Sensor)	----	----
62	Display Control Wiring Harness	239-46944-00	239-46944-00
63	Display Cover Wiring Harness	239-46617-00	239-46617-00
64	Control Box Panel	239-46508-00	239-46508-00
65	Strain Relief Bushing 7/8"	239-80372-00	239-80372-00
66	Snap-in Bushing 7/8"	239-80406-00	239-80406-00
67	Strain Relief Bushing 1/2"	239-44575-00	239-44575-00

\* Applies to all warranties

\*\* Ordering a complete burner rack may increase delivery time. Please order the specific component required for the quickest delivery.

\*\*\* No LP version model available.

\*\*\*\* No Low Nox versions available over 400K btuh.

▲ Applies when "E" is present in model number (Example: D38T155E3N).

- 1 For serial numbers PRIOR to GB13067706.
- 2 For serial numbers AFTER and including GB13067706.
- 3 For serial numbers PRIOR to HA14465923.
- 4 For serial numbers including and AFTER HA14465923.



# **BRADFORD WHITE®**

W A T E R H E A T E R S

Ambler, PA

For U.S. and Canada field service,  
contact your professional installer or  
local Bradford White sales representative.

**Sales/800-523-2931**  
**Fax/215-641-1670**  
**Parts Fax/215-641-2180**

**Technical Support/800-334-3393**  
**Fax/269-795-1089**

**Warranty/800-531-2111**  
**Fax/269-795-1089**

**International:**  
**Telephone/215-641-9400**  
**Telefax/215-641-9750**



# **BRADFORD WHITE-CANADA® INC.**

Mississauga, ON

**Sales/866-690-0961**  
**905-238-0100**

**Fax/905-238-0105**

**Technical Support/800-334-3393**

**Email**

**parts@bradfordwhite.com**  
**techserv@bradfordwhite.com**

**www.bradfordwhite.com**