

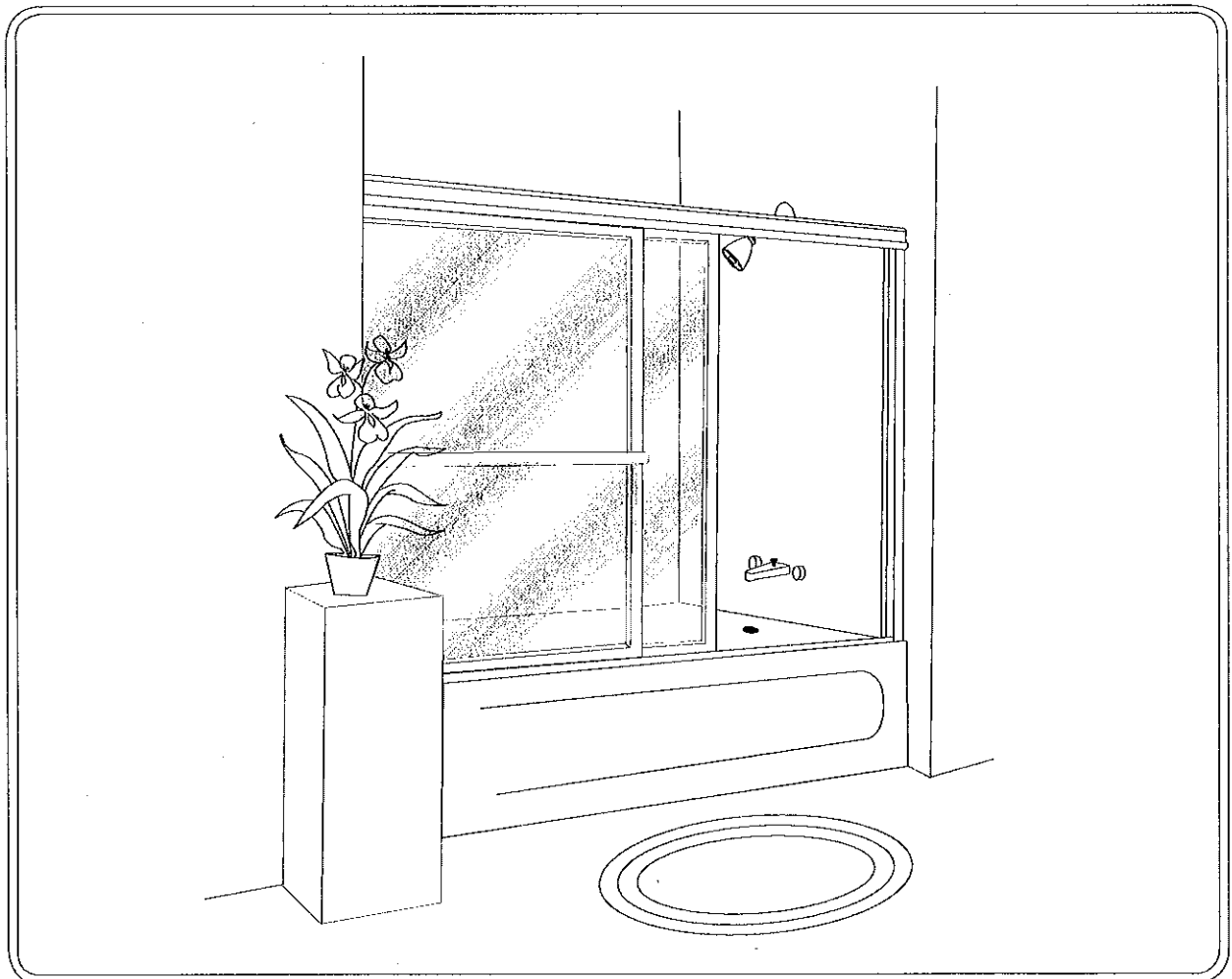

INSTALLATION INSTRUCTIONS

UNIT No. 6150 & 7150 BATH ENCLOSURE



MAINTENANCE: Two primary materials are used to manufacture your new Basco enclosure: tempered glass and anodized aluminum. To assure a long lasting finish on the enclosure, wipe it down with a towel after each use. Never use a scouring agent to clean the aluminum.

For occasional, more concentrated cleaning efforts, we find that *Lysol Bathroom Cleaner* works extremely well. Be sure that any over spray falling on the aluminum frame is rinsed thoroughly and dried. Many over-the-counter cleaners, if applied to the aluminum and left on, will harm the metal finish and cause permanent damage, even though their directions indicate safe use on shower doors.

INSTALLATION NOTES: Unpack your unit carefully and inspect for freight damage. Lay out and identify all parts using the instruction sheets as a reference. Before discarding the carton, check to see that no small hardware parts have fallen to the bottom of the box. If any parts are damaged or missing, refer to the descriptions noted in the instructions when contacting your dealer for replacements.

Handle the glass panels carefully and protect the edges.

Please wear safety glasses whenever drilling or cutting. When drilling holes in the ceramic tile or marble, use a center punch and hammer to carefully break the surface glaze so the drill can start without skidding.

To install your BASCO Shower Door you will need the following: tape measure, level, #2 Phillips screwdriver, 3/16" wrench, drill, 1/8" and 3/16" drill bits, hacksaw, pencil, and caulking (clear silicone recommended). Optional tools include a miter box for cutting parts to length, files, center punch, and masking tape.

NOTE: Tempered glass cannot be cut.

Although safety tempered glass is very resistant to breakage, the glass can still break if unequal pressure is placed on it during installation. Use caution. In addition, the sharp corners of the panels can damage tile and floor surfaces, so it is best to handle the glass panels carefully and protect the edges.

6150/7150 PARTS LIST

- | | |
|--|--|
| <ul style="list-style-type: none"> A. 1 Tub Track with Vinyl B. 2 Wall Jambs C. 6 Plastic Wall Anchors D. 6 #8 x 1 1/2" Truss Head Screws E. 2 Nylon Spacers F. 1 Header G. 2 Glazed Panels H. 4 Nylon Roller Bearings J. 4 #8-32 x 3/8" Hex Head Screws K. 4 Towel Bar Trim Rings | <ul style="list-style-type: none"> L. 2 Towel Bar Brackets M. 2 Towel Bars N. 2 #10-24 x 7/8" Truss Head Screws P. 2 #10-24 x 1 1/8" Flat Head Screws R. 2 Acrylic Finger Pulls S. 2 Basco Decals T. 1 Nylon Bottom Guide U. 1 #6 x 3/8" Pan Head Screw V. 2 Stainless Bumper Inserts W. 2 Soft Jamb Bumpers |
|--|--|

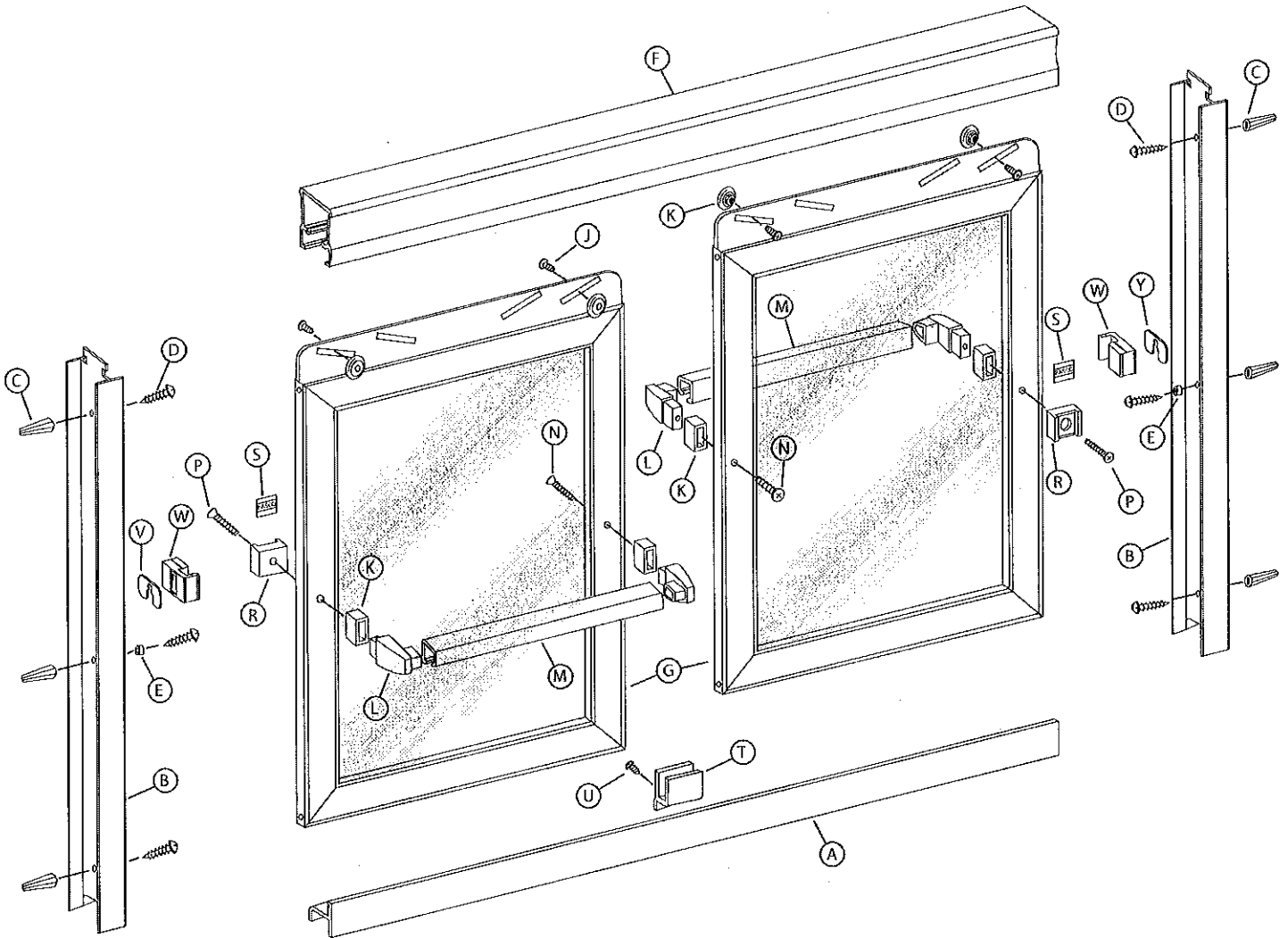

1

Measure the wall-to-wall opening at the center of the tub rim. Cut the tub track [A] 1/16" short of this dimension. An inexpensive miter box (available at your local hardware store) will help you get clean square cuts.

Position the tub track in the center of the tub rim with the tall leg to the exterior. It may be necessary to file a radius on the ends of the tub track and wall jambs to match the corners of the enclosure.

Press both wall jambs [B] into position over the tub track. Masking tape can be used to hold the parts in place temporarily.

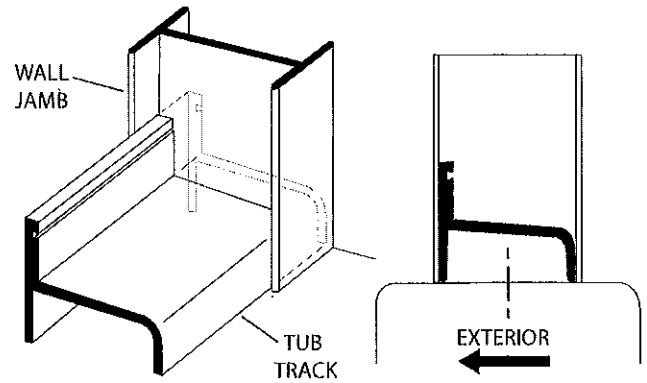

2

Use a level to plumb both wall jambs [B] then mark the pre-drilled hole locations on the wall. Lightly mark along both sides of the tub track [A] with a pencil, then remove all parts.

For tile or marble walls, drill six 3/16" diameter holes and insert the plastic wall anchors [C]. Attachments to fiberglass or acrylic units can be made in two ways. If reinforcement is built into the wall of unit, drill six 1/8" holes to install mounting screws directly into the reinforcement. If walls are not reinforced, drill six 3/16" holes and install plastic wall anchors or toggle bolts (toggle bolts not supplied by Basco).

CAUTION: The track should never be screwed to the tub. This will damage the tub and cause leakage.

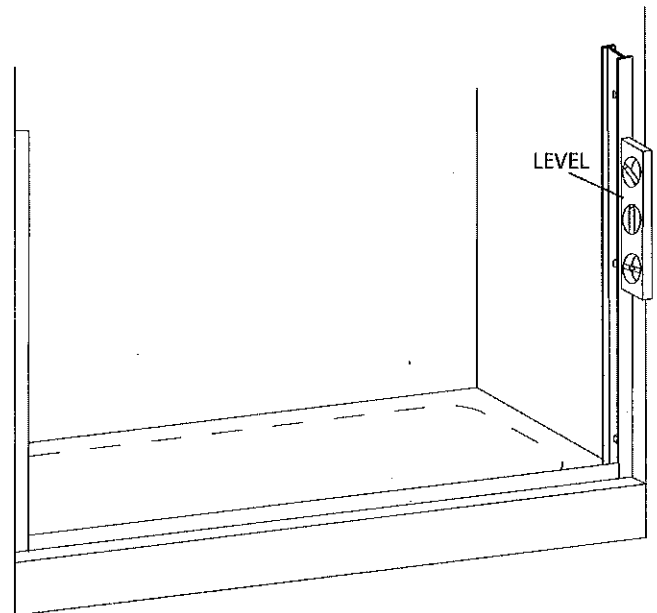

3

Before replacing the tub track [A], force a slight downward bow in the extrusion. This will ensure the track fits tight to the tub. Run two beads of caulk inside the penciled marks on the tub rim. Place the tub track in the exact position marked in Step #2 and seat it firmly in the caulking.

NOTE: Improper caulking will result in leaks.

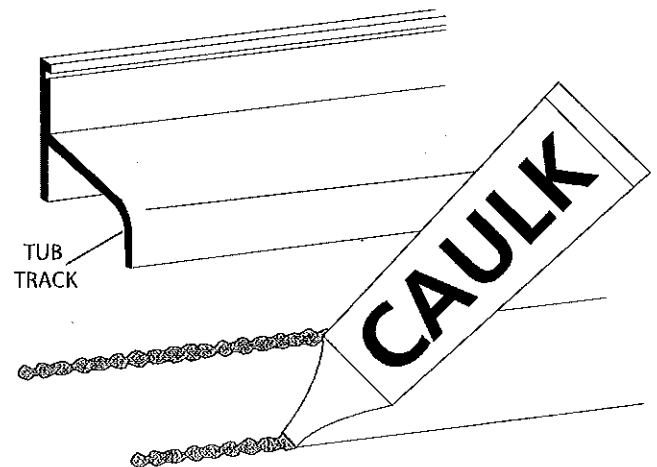

4

Replace one wall jamb [B] and attach to wall with two #8 x 1 1/2" truss head screws [D] inserted through the top and bottom holes. Slip a nylon spacer [E] over a #8 x 1 1/2" truss head screw and install in the center hole of the wall jamb. Check jamb for plumb and tighten screws.

NOTE: Do not over-tighten the jamb screws.

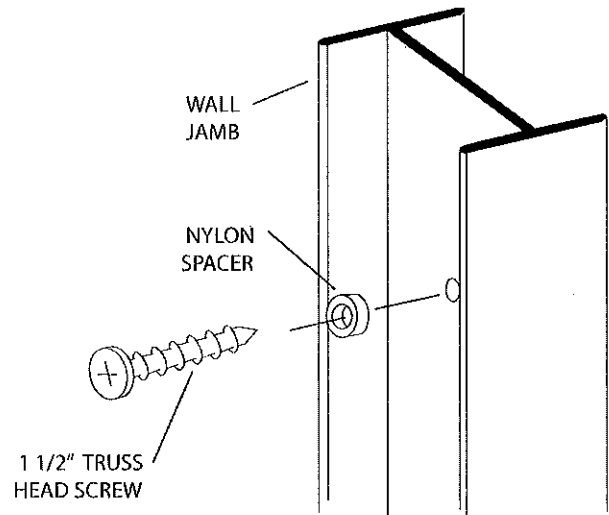

5

This bath enclosure is equipped with safety tee-lock wall jambs. When properly installed, the header is permanently locked to the wall jambs and cannot be accidentally dislodged.

Measure the wall-to-wall opening at the top of the wall jambs [B] and cut the header [F] 1/16" short of this dimension. Check the header for fit.

Slide the safety tee-lock of the un-mounted wall jamb [B] into the end of the header. The header is reversible so that either face may be turned to the exterior of the unit. Holding the header at an angle, engage the other end onto the mounted wall jamb. Pivot the header into place, then slide the loose wall jamb to the wall and press into position on the tub track. Attach the jamb to the wall per instructions in Step #4.

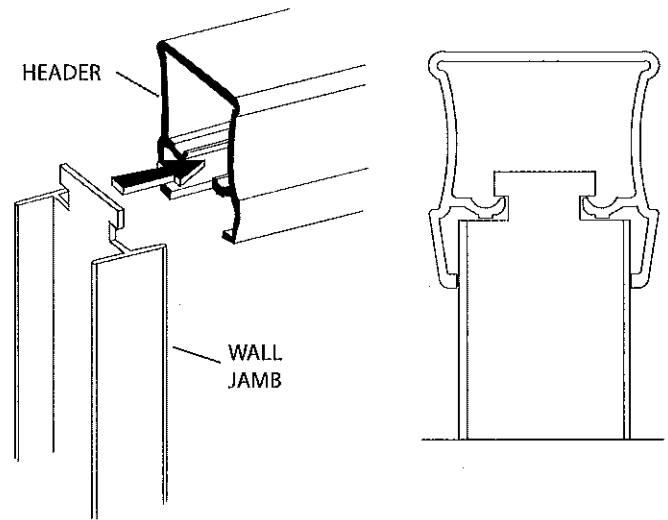

6

NOTE: Obscure or etched glass doors should be installed with the rough surface of the glass to the exterior of the unit.

On doors with obscure or etched glass, there is an interior and exterior glazed door panel [G] as determined by the position of the top bearing fin. Door panels with clear glass are interchangeable.

Attach the four nylon roller bearings [H] to the door panels as shown, using #8-32 x 3/8" hex head screws [J] centered in the outside slots in the top bearing fins.

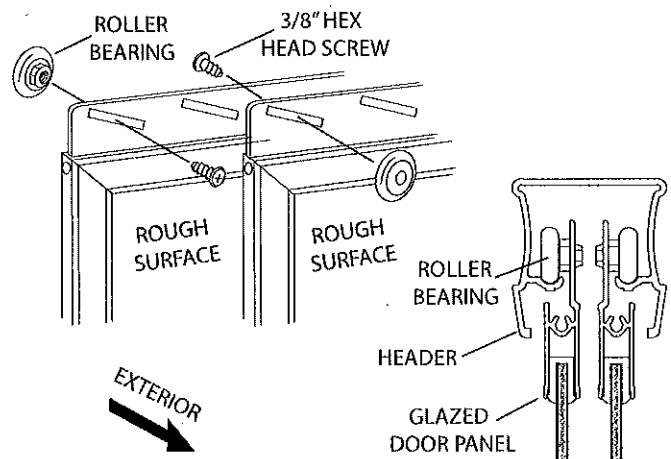

7

Lift the interior panel (with the rough surface closest to the top fin) into position with the rollers engaging the roller slot in the header [F].

Repeat for the exterior panel (rough surface away from the top fin).

If the door panels are not parallel to the wall jambs, remove them from the header and adjust the rollers up or down to compensate.

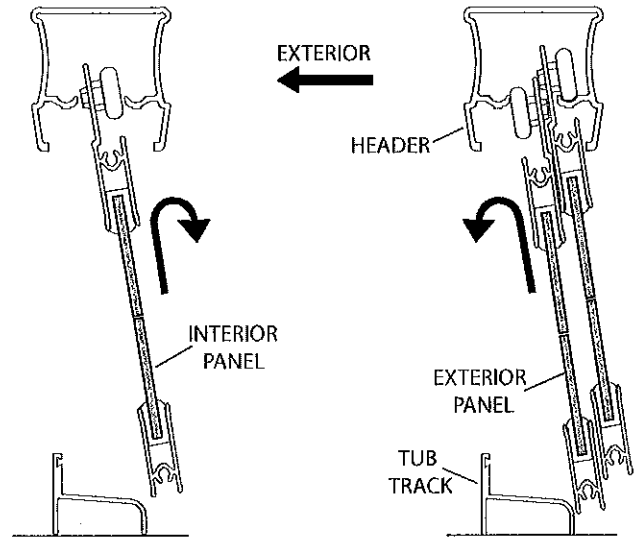

8

Before finishing the installation it is necessary to determine the proper closed position of the doors. For maximum water-proofing, position the interior panel closest to the shower head, as shown in the detail.

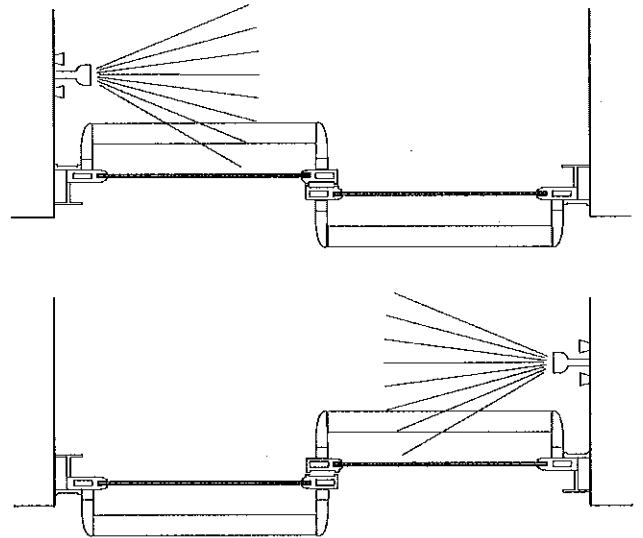

9

Slide the four towel bar trim rings [K] over the clear acrylic towel bar brackets [L] and press the brackets into the ends of the two towel bars [M].

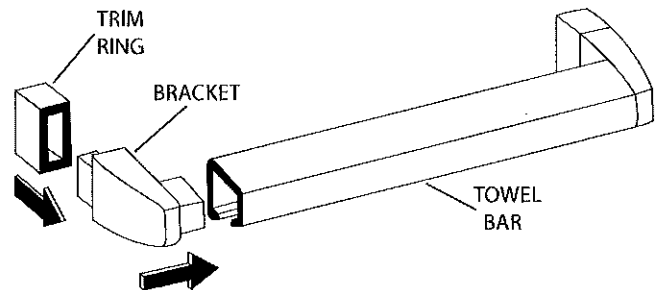

10

Attach a towel bar assembly (with the open slot in the bar downward) to the interior panel with a #10-24 x 7/8" truss head screw [N] thru the inner rail. Insert a #10-24 x 1 1/8" flat head screw [P] thru an acrylic finger pull [R], thru the outer rail and into the outer towel bar bracket. Peel the backing from a Basco decal [S] press it into the recess in the acrylic finger pull.

Repeat for the exterior door panel.

NOTE: Do not over-tighten the towel bar screws.

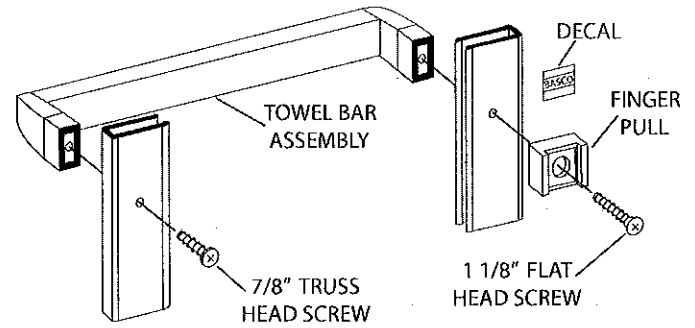

11

Locate the nylon bottom guide [T] in the middle of the tub track [A] with the door panels in the position shown. With a 7/64" bit, drill a hole into the V-groove through the mounting hole in the bottom guide. Install the bottom guide with a #6 x 3/8" pan head screw [U] thru the drilled hole.

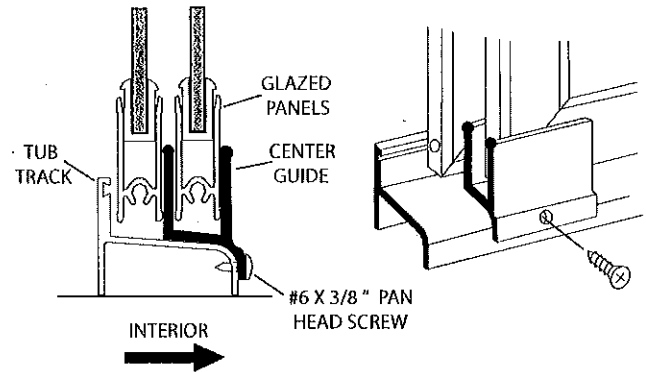

12

Slide the stainless steel bumper inserts [V] into the two soft vinyl jamb bumpers [W]. Align the slots in the bumpers with the outer rails of the door panels and snap the bumpers downward over the center wall jamb screws [D] with the nylon spacers [E] (see Step #4).

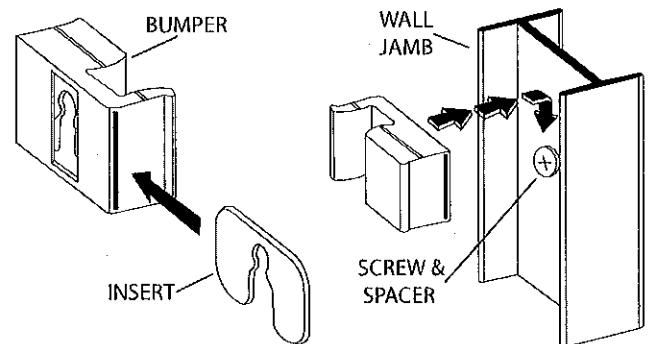

13

Neatly caulk each end of the tub track [A] where it meets the wall jambs [B] and the interior edge of the wall jambs as shown. Run a bead of caulking along the interior edge of the tub track.

NOTE: The caulking should be allowed to cure for twenty-four hours before using your new bath enclosure.

