

BASCO®

SHOWER ENCLOSURES

INSTALLATION
INSTRUCTIONS

UNIT No. 3600 FRAMELESS PIVOT SHOWER DOOR

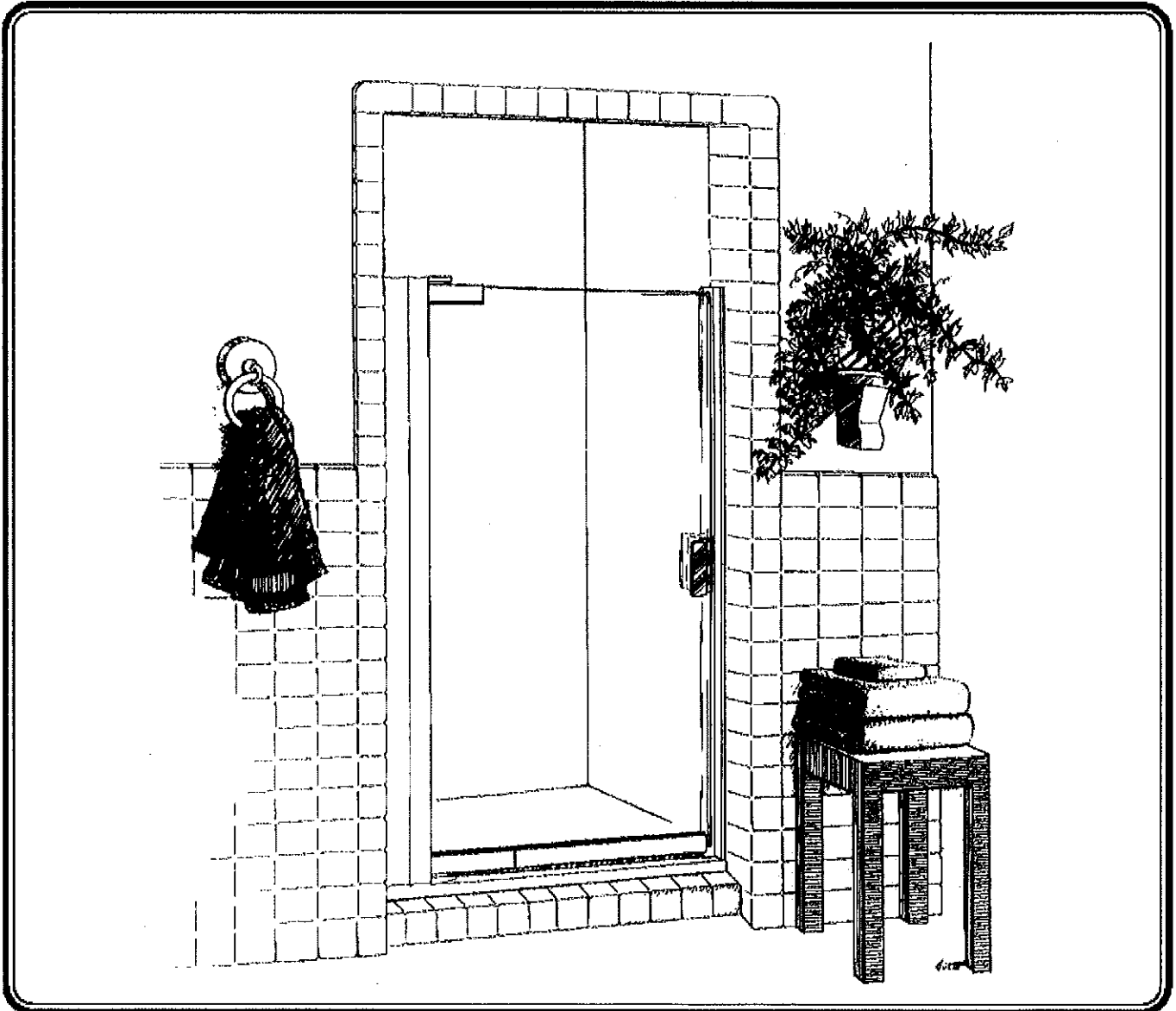

MAINTENANCE: Two primary materials are used to manufacture your new Basco enclosure: tempered glass and anodized aluminum. To assure a long lasting finish on the enclosure, wipe it down with a towel after each use. Never use a scouring agent to clean the aluminum.

For occasional, more concentrated cleaning efforts, we find that *Lysol Bathroom Cleaner* works extremely well. Be sure that any over spray falling on the aluminum frame is rinsed thoroughly and dried. Many over-the-counter cleaners, if applied to the aluminum and left on, will harm the metal finish and cause permanent damage, even though their directions indicate safe use on shower doors.

INSTALLATION NOTES: Unpack your unit carefully and inspect for freight damage. Layout and identify all parts using the instruction sheets as a reference. Before discarding the carton, check to see that no small hardware parts have fallen to the bottom of the box. If any parts are damaged or missing, refer to the descriptions noted in the instructions when contacting your dealer for replacements.

Handle the glass panels carefully and protect the edges.

Please wear safety glasses whenever drilling or cutting. When drilling holes in the ceramic tile or marble, use a center punch and hammer to carefully break the surface glaze so the drill can start without skidding.

To install your BASCO Shower Door you will need the following: tape measure, level, #2 Phillips screwdriver, 3/16" wrench, drill, 1/8" and 3/16" drill bits, hacksaw, pencil, and caulking (clear silicone recommended). Optional tools include a miter box for cutting parts to length, files, center punch, and masking tape.

NOTE: Tempered glass cannot be cut.

Although safety tempered glass is very resistant to breakage, the glass can still break if unequal pressure is placed on it during installation. Use caution. In addition, the sharp corners of the panels can damage tile and floor surfaces, so it is best to handle the glass panels carefully and protect the edges.

- | | | |
|----------------------------------|--------------------------------|-----------------------------------|
| A. 1 Curb | J. 6 Plastic Wall Anchors | T. 3 #8 x 1 1/2" Flat Head Screws |
| B. 1 Roll of Tape (double-stick) | K. 3 #8 x 2" Truss Head Screws | U. 1 Door Handle (w/ Magnet) |
| C. 1 Pivot Jamb Seal Vinyl | L. 1 Glazed Door Panel | V. 1 Door Handle Vinyl (8") |
| D. 1 Pivot Jamb | M. 1 Bottom Rail (See Note) | W. 1 Drip Rail |
| E. 2 Pivot Brackets | N. 2 #10 x 7/16" Set Screws | X. 1 Roll Drip Tape |
| F. 3 #6 x 3/8" Truss Head Screws | P. 2 Pivot Blocks | Y. 2 Drip Plugs |
| G. 2 #8 x 1/8" Allen Set Screws | R. 2 Nylon Bushings | AA. 4 Rail End Caps |
| H. 1 Allen Wrench (5/64") | S. 1 Strike Jamb (w/ Magnet) | BB. 1 BASCO Decal |

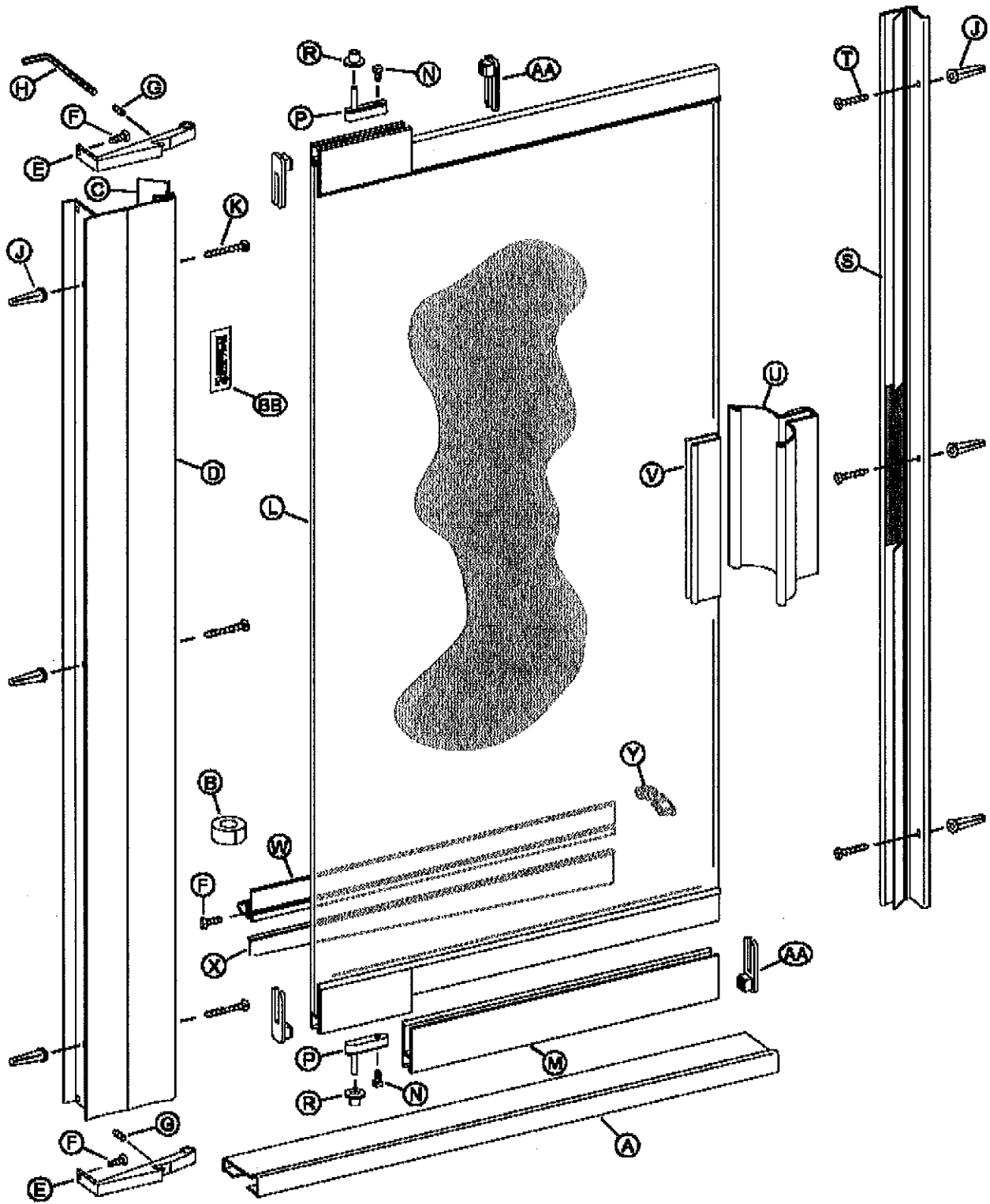

The Basco 3600 Frameless Pivot Shower Door is completely reversible and may be installed pivot-right or pivot-left. Refer to the illustration to determine the correct position for your installation. For maximum waterproofing, the pivot jamb should always be opposite the shower head. These instructions depict a pivot-left installation.

CAUTION: For safety, the door must *always* open outward.

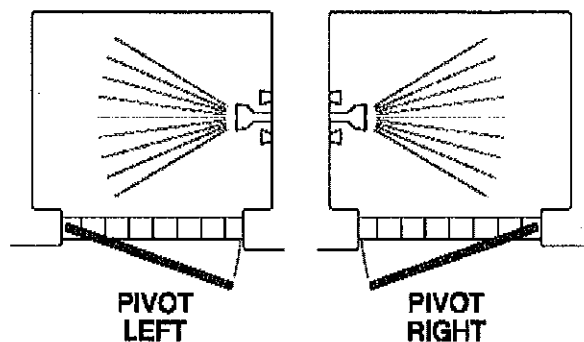

2

Note: The 3600 unit may be installed without using the sloped curb [A] provided. Its use is definitely recommended for positive water control on shower sills with little or no slope.

Measure the wall to wall opening at the shower sill and cut the curb to the exact length. File the ends of curb as necessary to fit the corner contours of the enclosure. Place the curb on the shower sill with the **RAISED** portion to the exterior of the enclosure. Make sure the curb is centered on the sill and lightly mark its position on the sill with a pencil. Remove the curb from the sill.

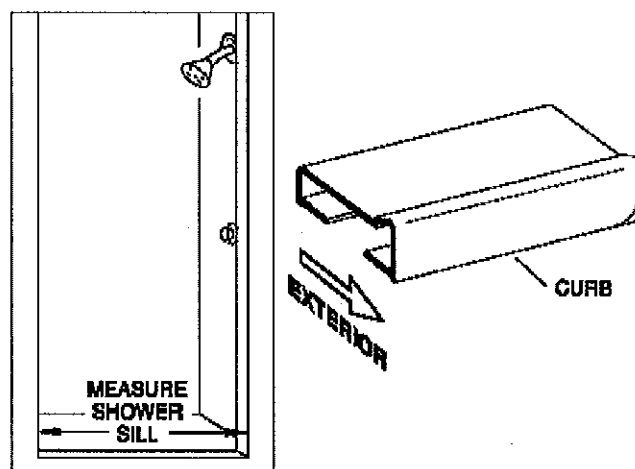

3

Run two beads of caulk along the flat surfaces on the bottom of the curb [A]. Then replace the curb on the shower sill in the exact position marked in Step #2. Press firmly into place with the raised portion to the exterior of the enclosure.

NOTE: Improper caulking will result in leaks.

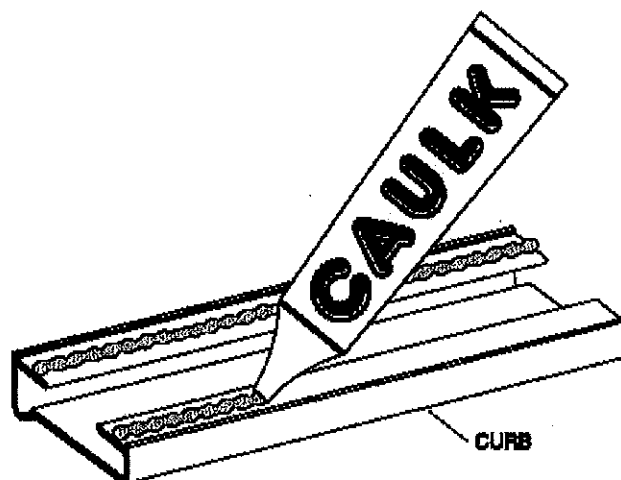

4

Cut the clear pivot jamb seal vinyl [C] 3/4" shorter than the pivot jamb [D]. Slide the jamb seal vinyl into the slot in the pivot jamb. Lubricating the vinyl with a small amount of soapy water will help installation. Slide one of the pivot brackets [E] into the bottom of the pivot jamb. Lock it in place with a #6 x 3/8" truss head screw [F] and a #8-32 x 1/8" set screw [G] (a 5/64" Allen wrench [H] is provided).

NOTE: Set screws [F] are pre-installed.

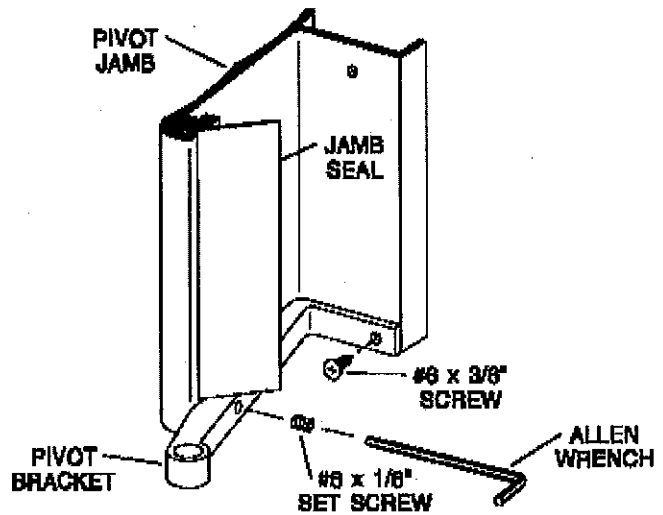

5

Place the pivot jamb assembly on the curb [A] with the exterior face lined up with the raised edge of the curb. Use a level to plumb the jamb then mark the mounting hole locations. Remove the jamb and drill the mounting holes.

For tile or marble walls, drill three 3/16" diameter holes and insert the plastic wall anchors [J]. Attachments to fiberglass or acrylic units can be made in two ways. If reinforcement is built into the wall of the unit, drill three 1/8" diameter holes to install mounting screws directly into the reinforcement. If walls are not reinforced, drill 3/16" holes and install plastic wall anchors or Molly bolts (Molly bolts are not supplied by BASCO).

Replace the pivot jamb and attach to the wall with three #8 x 2" truss head screws [K].

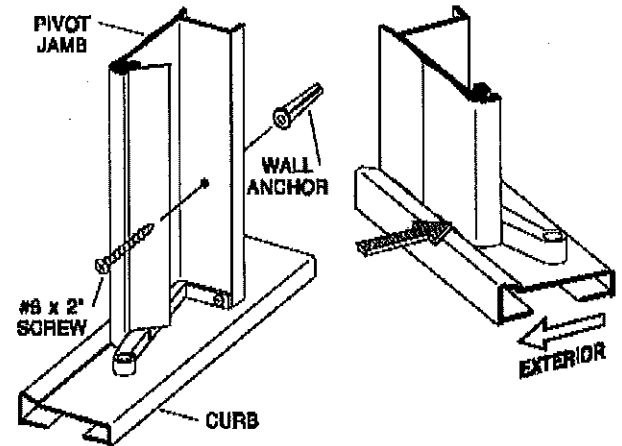

6

NOTE: Obscure glass or etched glass doors should be installed with the rough or patterned surface of the glass to the exterior of the unit.

Glazed doors [L] with obscure or etched glass will have short rails installed with full width vinyl on both ends. Determine which end will be the bottom. Using a mallet or a hammer and wood block (never a hammer alone), carefully drive the bottom rail [M] over the bottom edge of the glass and vinyl, (spraying glass cleaner or water onto the vinyl will make assembly easier), snug to the factory installed rail. Both rails should be set back 1/8" from the pivot edge of the door and the bottom rail should end 1/8" from the strike edge. Trim the excess vinyl even with the ends of the rails.

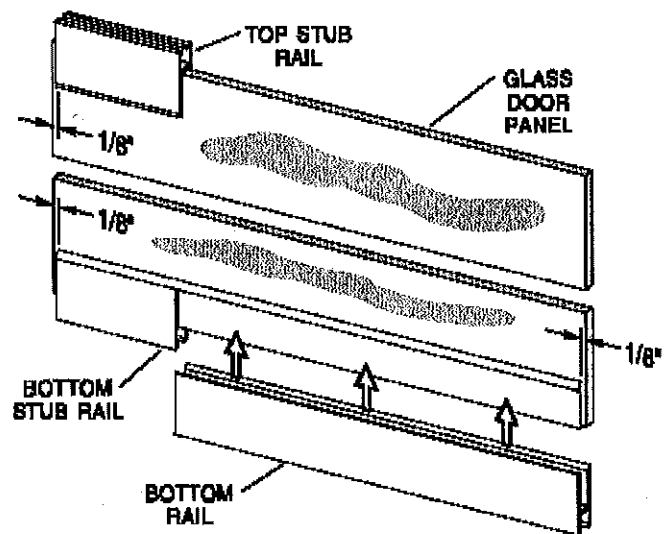

7

Thread the two #10-24 x 7/16" square head set screws [N] into the tapped holes in the pivot blocks [P]. Slide the pivot blocks into the top and bottom rails of the glass door panel [L] with the stainless steel pins toward the pivot side of the door (see details).

Measure the distance from wall to wall directly above the curb (Dim. "A"). Deduct 3 3/4" from this amount and position the pivot pins this exact distance (Dim "B") from the strike edge of the glass. Tighten the set screws just enough to prevent the pivot blocks from moving (finger tight plus a quarter turn). A 3/16" wrench (not supplied by BASCO) will fit the set screw heads.

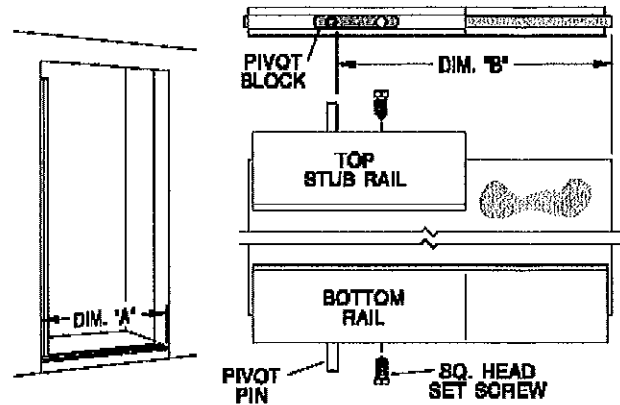
**8**

Insert a nylon pivot bushing [R] into the bottom pivot bracket [E]. Slip the second pivot bushing over the top pivot pin on the door panel [L]. Position the door by inserting the bottom pivot pin into the bottom pivot bracket. Hold the door panel vertical and slide the top pivot bracket into the pivot jamb [D] and over the top pivot pin and pivot bushing. Secure the top pivot bracket with a #6 x 3/8" truss head screw [F] and a #8-32 x 1/8" allen set screw [G].

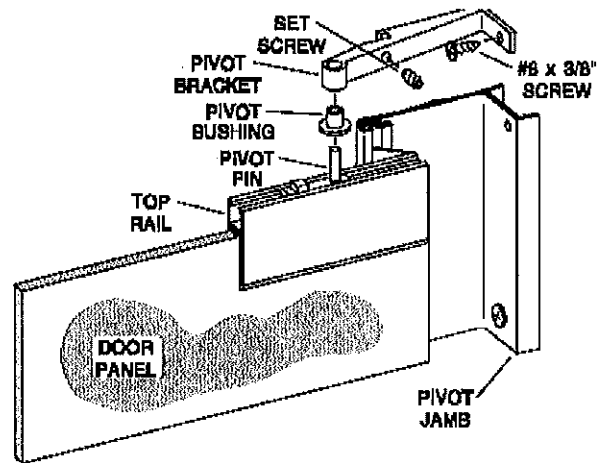
**9**

Measure the height of the glass door and divide in half, using this measurement mark the center of the door panel. Center the handle vinyl at the previous mark. Align the handle to the vinyl and with a non metal hammer drive the handle onto door. Place the strike jamb on the door with about one inch of the strike jamb extending above the door. Close the door and align the door to the bottom curb. Mark the position of the strike jamb with a pencil. open the door and remove the strike jamb. Align the jamb to the pencil mark and mark the center hole only, remove the jamb and drill the hole. Insert a plastic anchor in the center hole, replace the jamb and attach with one #8 x 1 1/2" flat head screw. Close the door and check the alignment of the jamb to the door, if the door is slightly bowed push the jamb to the door. Hold the jamb into place, open the door and mark the top hole location, repeat for the bottom. Loosen the center screw and move the strike jamb slightly so you can drill the other two holes. Clean drill dust from wall and curb, install plastic anchors align the hole in the top of the strike jamb to top hole in wall, install screw, repeat for bottom hole, re-tighten center screw..

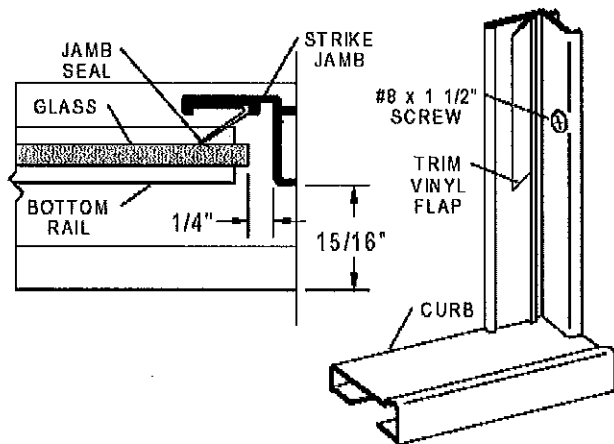

10

Slide the door handle [U] with magnet onto the strike edge of the door panel [L]. Close the door and slide the handle up or down until the two magnetic strips are aligned. Use a pencil or masking tape to mark the location of the handle on the door.

Slip the door handle vinyl [V] onto the door between the marks and carefully drive the door handle on the door panel (USING RUBBER OR PLASTIC Mallet). Spraying glass cleaner or water onto the vinyl and handle will make the assembly easier.

Close the door and check the clearance with the strike jamb. If necessary, loosen the set screws [N] on the top & bottom pivot blocks [P] and adjust the door to align the strike magnets. When the door is properly aligned, tighten the set screws securely.

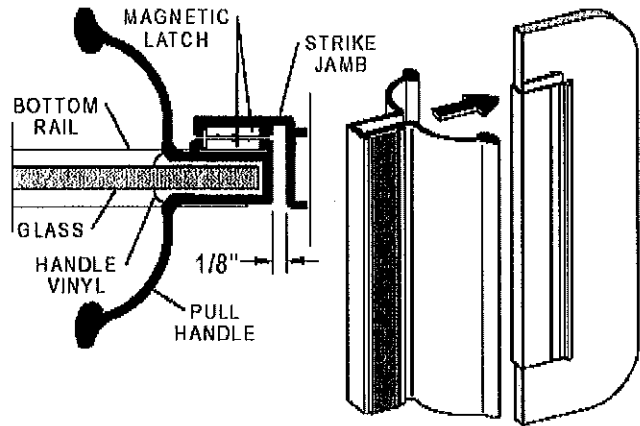

11

Clean the inside edge of the bottom door rail and the flat side of the drip rail thoroughly with rubbing alcohol to ensure proper adhesion of the double stick tape [B]. Unroll the tape and carefully attach it to the back of the drip rail (do not peel the tape backing yet).

Insert the tapered drip vinyl [X] into the drip rail. Position the drip rail flush with the bottom and pivot side of the door panel [L], then raise the strike side until the bottom edge of the drip vinyl is parallel to the curb [A]. Mark the location of each end of the drip rail with a pencil. Peel off the tape backing and carefully press the drip rail to the door in the position marked.

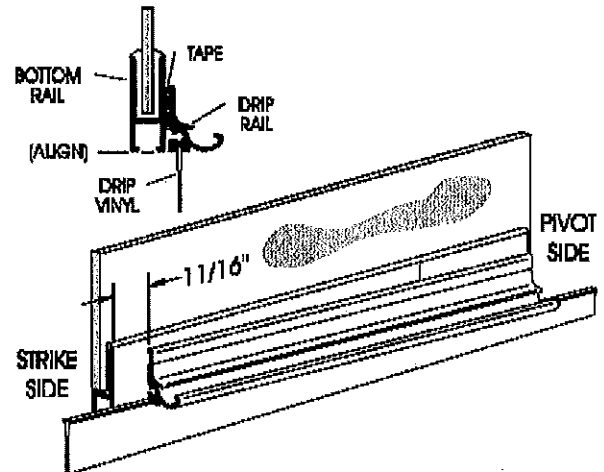

12

Adjust the drip vinyl [X] by sliding it left or right until it just touches the curb. Trim the vinyl (flush with the pivot end and notch 1/2" longer than the drip rail as shown on the strike end). Secure it with one #6 x 3/8" truss head screw [F] in the pivot end of the drip rail.

The drip plug [Y] is supplied with a left and right hand plug together. Break the right and left drip plug apart and insert the appropriate plug into the high (strike) side of the drip rail. Discard the unused drip plug. Peel off the tape backing and carefully press the drip rail to the door in the marked position.

NOTE: Cleaners with alcohol content can dissolve the adhesive that attaches the drip rail. To prevent this possibility, place a small bead of clear sealant at the top of the drip rail where it is attached to the bottom rail.

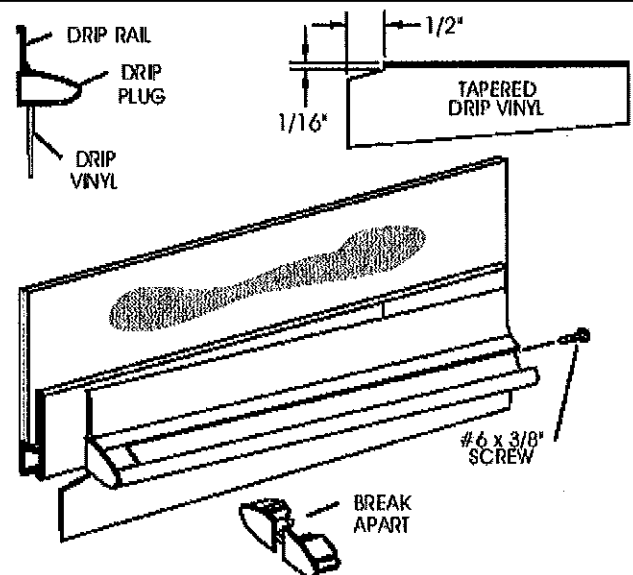

13

Press the four rail end caps [AA] into the ends of the top and bottom door rails.

Peel the backing from the BASCO decal [BB] and apply it to the pivot jamb as shown in the detail.

NOTE: Do not use a metal hammer to install the end caps.

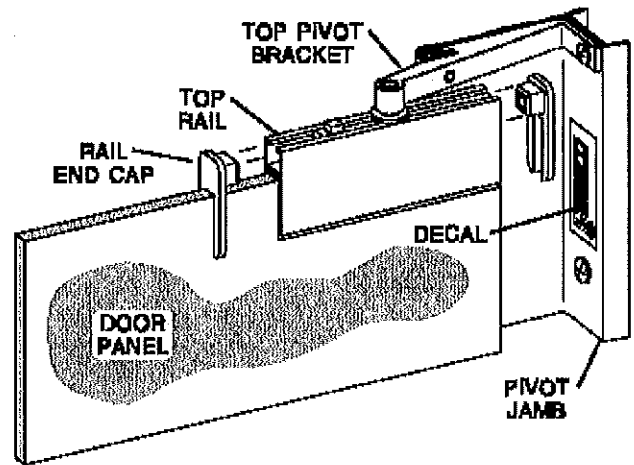

14

Neatly caulk the inside perimeter of the shower curb and the pivot and strike jambs.

NOTE: The caulking should be allowed to cure for twenty-four hours before using your new shower enclosure.

