



COMMERCIAL REPLACEMENT PARTS LIST

Power Direct Vent PDV(S&T) Models



Includes Hydrojet®
Total Performance System

Effective: September, 2005
ECO 6840

**NOTE: BOTH MODEL AND SERIAL
NUMBERS ARE REQUIRED FOR
ORDERING REPLACEMENT PARTS**

Dimensions and specifications
subject to change without notice.

PDV "S" Series

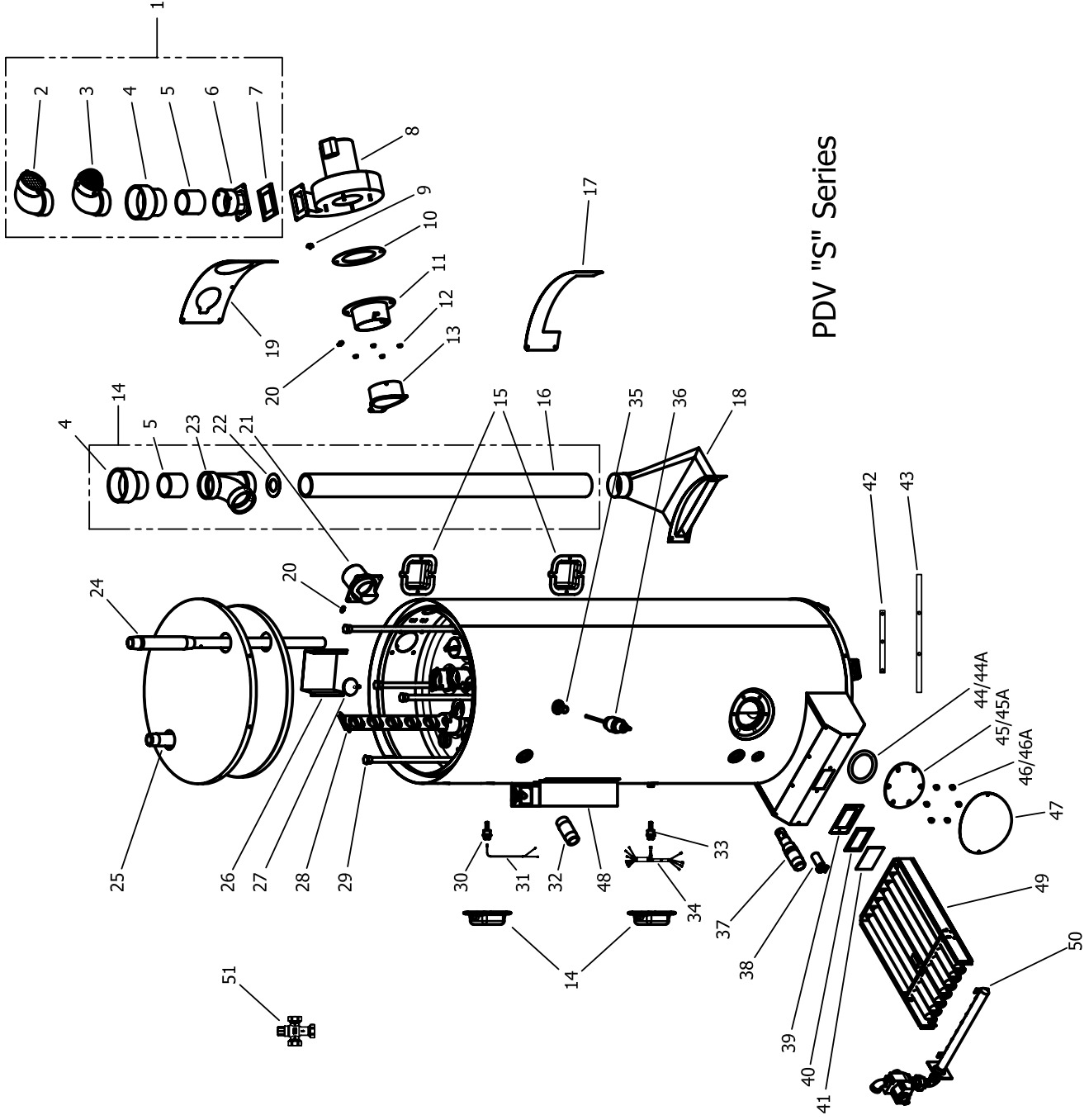

Item	part description	Model	Model	Model	Model	Model	Model
		PDV/80S150(E)*(N,X)	PDV/80S200(E)*(N,X)	PDV/80S250(E)*(N,X)(A)	PDV/100S150(E)*(N,X)	PDV/100S200(E)*(N,X)	PDV/100S250(E)*(N,X)(A)
1	Vent Kit	243-42776-01	243-42776-01	243-42776-02	243-42776-01	243-42776-01	243-42776-02
2	Vent Elbow	239-40579-00	239-40579-00	239-40579-00	239-40579-00	239-40579-00	239-40579-00
3	Intake Terminal	239-42642-01	239-42642-01	239-42642-02	239-42642-01	239-42642-01	239-42642-02
4	Vent Reducer	---	---	239-42581-00	---	---	239-42581-00
5	3" PVC Pipe	---	---	239-40903-00	---	---	239-40903-00
6	Blower Vent Adaptor	239-42434-00	239-42434-00	239-42434-00	239-42434-00	239-42434-00	239-42434-00
7	Blower Receptacle Gasket	239-42479-00	239-42479-00	239-42479-00	239-42479-00	239-42479-00	239-42479-00
8	Blower	239-42371-00	239-42371-00	239-42371-00	239-42371-00	239-42371-00	239-42371-00
9	Temperature Switch	239-43238-03	239-43238-03	239-43238-03	239-43238-03	239-43238-03	239-43238-03
10	Blower Intake Gasket	239-81161-00	239-81161-00	239-81161-00	239-81161-00	239-81161-00	239-81161-00
11	Blower Mounting Flange	239-41525-00	239-41525-00	239-41525-00	239-41525-00	239-41525-00	239-41525-00
12	Nut 1/4-20 Hex	239-43297-00	239-43297-00	239-43297-00	239-43297-00	239-43297-00	239-43297-00
13	Collector to Blower Transition	239-41505-00	239-41505-00	239-41505-00	239-41505-00	239-41505-00	239-41505-00
14	Air Intake Assembly	243-42777-03	243-42777-03	243-42777-04	243-42777-01	243-42777-01	243-42777-02
15	Utility Cover	239-80281-03	239-80281-03	239-80281-03	239-80281-03	239-80281-03	239-80281-03
16	Air Intake Pipe	239-42429-02	239-42429-02	239-42429-02	239-42429-01	239-42429-01	239-42429-01
17	Cover Rear Boot	243-42403-00	243-42403-00	243-42403-00	243-42403-00	243-42403-00	243-42403-00
18	Combustion Box Boot	239-42260-00	239-42260-00	239-42260-00	239-42260-00	239-42260-00	239-42260-00
19	Blower Escutcheon	243-42408-00	243-42408-00	243-42408-00	243-42408-00	243-42408-00	243-42408-00
20	Blower Hose Barb	239-41553-00	239-41553-00	239-41553-00	239-41553-00	239-41553-00	239-41553-00
21	Air Inlet	239-42262-00	239-42262-00	239-42262-00	239-42262-00	239-42262-00	239-42262-00
22	Vent Orifice	243-42297-00	243-42297-00	243-42297-00	243-42297-00	243-42297-00	243-42297-00
23	Air Intake Tee	239-42402-00	239-42402-00	239-42402-00	239-42402-00	239-42402-00	239-42402-00
24	Cold Water Inlet Dip Tube (top)	229-43192-04	229-43192-04	229-43192-04	229-43192-05	229-43192-05	229-43192-05
25	Hot Water Outlet Nipple (top)	229-41573-01	229-41573-01	229-41573-01	229-41573-01	229-41573-01	229-41573-01
26	Cover Pressure Switch	239-41763-00	239-41763-00	239-41763-00	239-41763-00	239-41763-00	239-41763-00
27	Pressure Switch (Off to 2000ft)	239-44063-05	239-44063-04	239-44063-05	239-44063-05	239-44063-04	239-44063-05
28	Pressure Switch (Over 2000ft)	239-44063-05	239-44063-04	239-44063-04	239-44063-05	239-44063-04	239-44063-04
29	Flue Baffle	243-41455-00	243-41455-00	243-41455-00	243-41455-00	243-41455-00	243-41455-00
30	Anode Hex Head Magnesium	224-32758-24	224-32758-24	224-32758-24	224-32758-15	224-32758-15	224-32758-15
31	Anode Hex Head Aluminum	224-38508-06	224-38508-06	224-38508-06	224-38508-03	224-38508-03	224-38508-03
32	Upper Thermostat Sensor	239-82033-00	239-82033-00	239-82033-00	239-82033-00	239-82033-00	239-82033-00
33	Wire Harness Upper Sensor	239-41569-00	239-41569-00	239-41569-00	239-41569-00	239-41569-00	239-41569-00
34	Hot Water Outlet (side)	229-40913-02	229-40913-02	229-40913-02	229-40913-02	229-40913-02	229-40913-02
35	Lower Thermostat Sensor	239-82034-00	239-82034-00	239-82034-00	239-82034-00	239-82034-00	239-82034-00
36	Wire Harness Lower Sensor	239-45363-00	239-45363-00	239-45363-00	239-45363-00	239-45363-00	239-45363-00
37	T/P nipple	229-32762-02	229-32762-02	229-32762-02	229-32762-02	229-32762-02	229-80982-00
38	T/P valve	230-30246-00	230-30246-00	230-30246-00	230-30246-00	230-30246-00	230-30246-00
39	Cold Water Inlet Nipple (side)	229-44731-00	229-44731-00	229-44731-00	229-44731-00	229-44731-00	229-44731-00
40	Drain Valve	265-42351-02	265-42351-02	265-42351-02	265-42351-02	265-42351-02	265-42351-02
41	Sight Glass Holder	239-42481-00	239-42481-00	239-42481-00	239-42481-00	239-42481-00	239-42481-00
42	Sight Glass Gasket	239-41635-00	239-41635-00	239-41635-00	239-41635-00	239-41635-00	239-41635-00
43	Sight Glass	239-41610-00	239-41610-00	239-41610-00	239-41610-00	239-41610-00	239-41610-00
44	Combustion Box Gasket - Sides	239-42430-00	239-42430-00	239-42430-00	239-42430-00	239-42430-00	239-42430-00
45	Combustion Box Gasket - Top & Bottom	239-41627-00	239-41627-00	239-41627-00	239-41627-00	239-41627-00	239-41627-00
46	Cleanout O-Ring	205-18427-00	205-18427-00	205-18427-00	205-18427-00	205-18427-00	205-18427-00
47	Cleanout Gasket (ASME)	---	---	205-32942-00	---	---	205-32942-00
48	Cleanout Cover	205-18428-00	205-18428-00	205-18428-00	205-18428-00	205-18428-00	205-18428-00
49	Cleanout Cover (ASME)	---	---	205-32941-00	---	---	205-32941-00
50	Screw 5/16-18 X 1/2 Hex	239-82166-00	239-82166-00	239-82166-00	239-82166-00	239-82166-00	239-82166-00
51	Screw 5/16-18 X 1/2 Hex (ASME)	---	---	239-32970-00	---	---	239-32970-00
52	Cleanout Jacket Cover	243-20299-00	243-20299-00	243-20299-00	243-20299-00	243-20299-00	243-20299-00
53	Mixing Valve (Optional)	239-43740-02	239-43740-02	239-43740-02	239-43740-02	239-43740-02	239-43740-02

*Applies to all warranties



PDV (S & T) Series

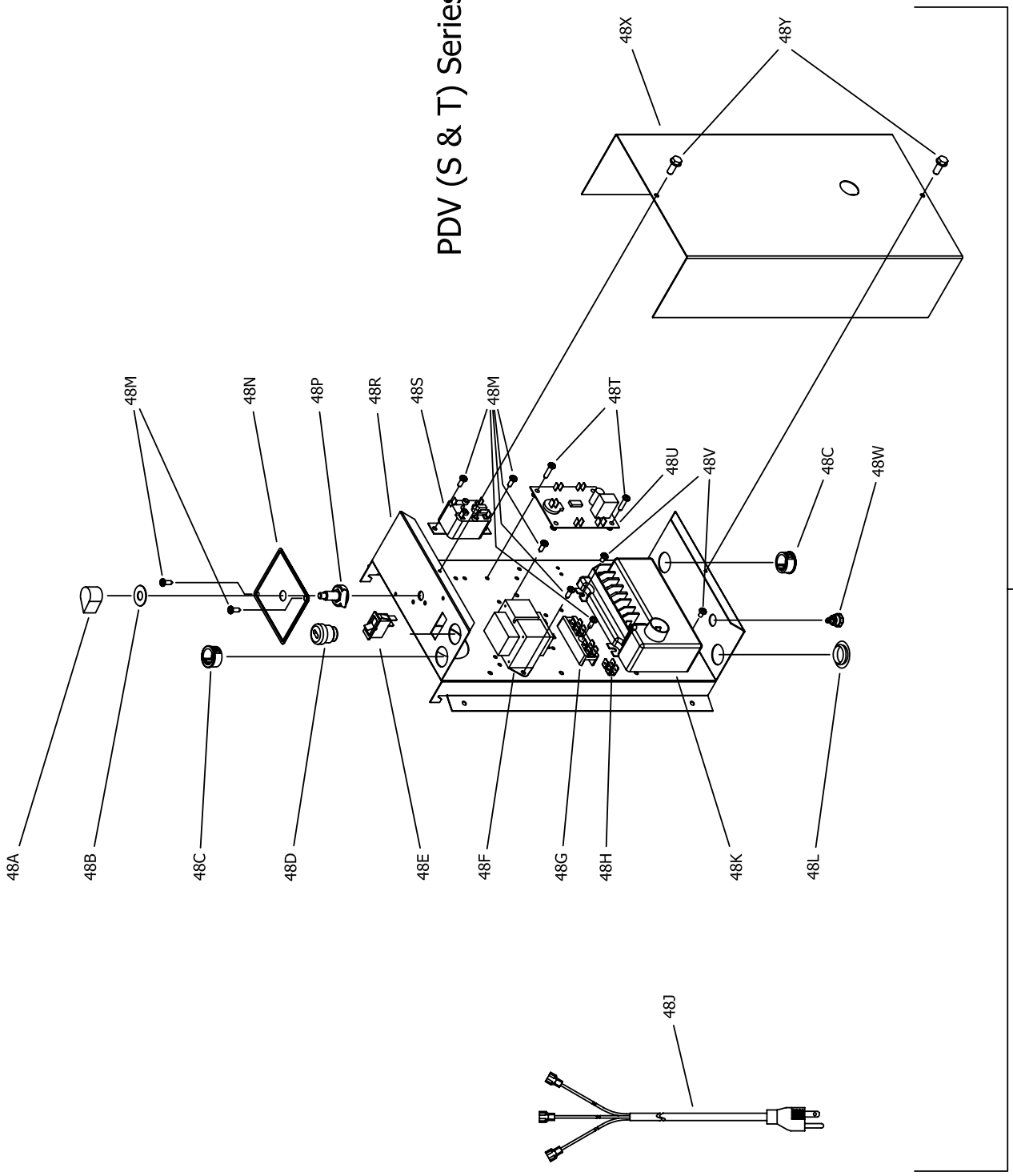

Item	part description	Model	Model	Model	Model	Model	Model	
		PDV/80S150(E)*(N,X)	PDV/80S200(E)*(N,X)	PDV/80S250(E)*(N,X)	PDV/80S300(E)*(N,X)	PDV/80S350(E)*(N,X)	PDV/80S400(E)*(N,X)	PDV/100S250(E)*(N,X)
48	Control Box Assembly**	243-44580-01	243-44580-01	243-44580-01	243-44580-01	243-44580-01	243-44580-01	243-44580-01
48A	Potentiometer Knob	239-41710-00	239-41710-00	239-41710-00	239-41710-00	239-41710-00	239-41710-00	239-41710-00
48B	Potentiometer Gasket	223-82047-00	223-82047-00	223-82047-00	223-82047-00	223-82047-00	223-82047-00	223-82047-00
48C	Snap-In Bushing	239-80406-00	239-80406-00	239-80406-00	239-80406-00	239-80406-00	239-80406-00	239-80406-00
48D	Bushing	239-44575-00	239-44575-00	239-44575-00	239-44575-00	239-44575-00	239-44575-00	239-44575-00
48E	Power Switch	239-41566-00	239-41566-00	239-41566-00	239-41566-00	239-41566-00	239-41566-00	239-41566-00
48F	Transformer	233-44072-01	233-44072-01	233-44072-01	233-44072-01	233-44072-01	233-44072-01	233-44072-01
48G	Terminal Block	239-80373-00	239-80373-00	239-80373-00	239-80373-00	239-80373-00	239-80373-00	239-80373-00
48H	Terminal Strip	239-80112-00	239-80112-00	239-80112-00	239-80112-00	239-80112-00	239-80112-00	239-80112-00
48J	Power Cord	239-80377-00	239-80377-00	239-80377-00	239-80377-00	239-80377-00	239-80377-00	239-80377-00
48K	Module	233-43128-00	233-43128-00	233-43128-00	233-43128-00	233-43128-00	233-43128-00	233-43128-00
48L	Plug Plastic	239-81415-05	239-81415-05	239-81415-05	239-81415-05	239-81415-05	239-81415-05	239-81415-05
48M	Screw #8-18 X .50	239-43736-00	239-43736-00	239-43736-00	239-43736-00	239-43736-00	239-43736-00	239-43736-00
48N	Temperature Label	238-44588-00	238-44588-00	238-44588-00	238-44588-00	238-44588-00	238-44588-00	238-44588-00
48P	Potentiometer	233-82054-00	233-82054-00	233-82054-00	233-82054-00	233-82054-00	233-82054-00	233-82054-00
48R	Control Box Panel	239-44576-00	239-44576-00	239-44576-00	239-44576-00	239-44576-00	239-44576-00	239-44576-00
48S	Relay Single Pole	233-41560-00	233-41560-00	233-41560-00	233-41560-00	233-41560-00	233-41560-00	233-41560-00
48T	Screw #8-18 X .75	239-43863-00	239-43863-00	239-43863-00	239-43863-00	239-43863-00	239-43863-00	239-43863-00
48U	Thermostat Board	233-41347-00	233-41347-00	233-41347-00	233-41347-00	233-41347-00	233-41347-00	233-41347-00
48V	Screw #8-18 X .25	239-43573-00	239-43573-00	239-43573-00	239-43573-00	239-43573-00	239-43573-00	239-43573-00
48W	Power Cord Bushing	239-80372-00	239-80372-00	239-80372-00	239-80372-00	239-80372-00	239-80372-00	239-80372-00
48X	Control Box Cover	239-44563-00	239-44563-00	239-44563-00	239-44563-00	239-44563-00	239-44563-00	239-44563-00
48Y	Screw 1/4-20 X .62 Hex Head	239-42637-00	239-42637-00	239-42637-00	239-42637-00	239-42637-00	239-42637-00	239-42637-00

*Applies to all warranties

**Ordering a complete Control Box Assembly may increase delivery time. Please order specific components for quickest delivery.

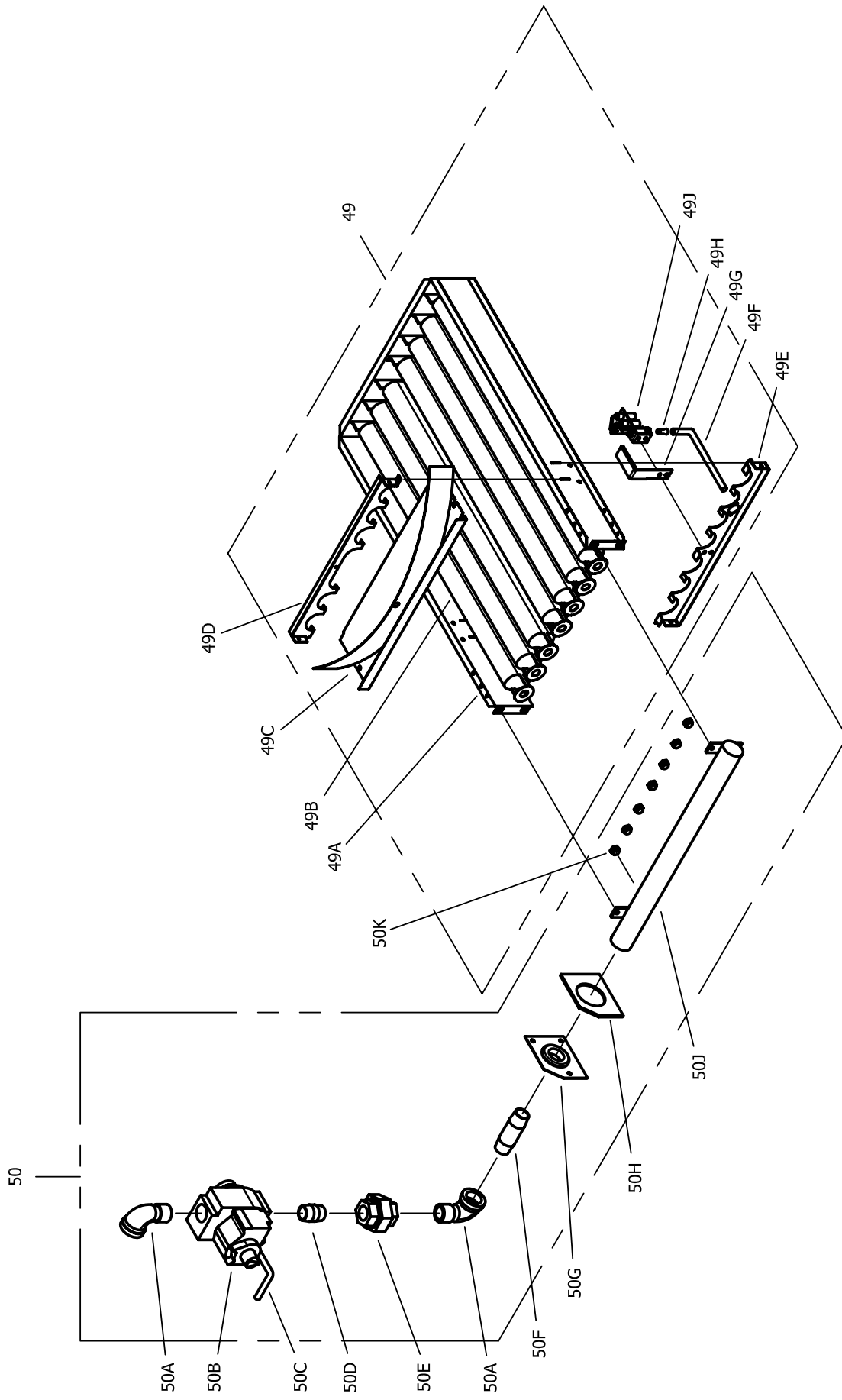

PDV "S" Series

Item	part description	Model	Model	Model	Model	Model	Model	Model	Model
		PDV/80S150(E)*(N,X)	PDV/80S200(E)*(N,X)	PDV/80S250(E)*(N,X)	PDV/80S150(E)*(N,X)	PDV/100S200(E)*(N,X)	PDV/100S150(E)*(N,X)	PDV/100S250(E)*(N,X)	PDV/100S250(E)*(N,X)
49	Burner Assembly (Natural Gas) **	243-42437-02	243-42437-02	243-42437-02	243-42437-02	243-42437-02	243-42437-02	243-42437-02	243-42437-02
	Burner Assembly (Natural Gas) (Lo-NOx) ** ▲	243-42437-01	243-42437-01	243-42437-01	243-42437-01	243-42437-01	243-42437-01	243-42437-01	243-42437-01
	Burner Assembly (LP Gas) **	243-42437-03	243-42437-03	243-42437-03	243-42437-03	243-42437-03	243-42437-03	243-42437-03	243-42437-03
49A	Burner Rack	239-81969-02	239-81969-02	239-81969-02	239-81969-02	239-81969-02	239-81969-02	239-81969-02	239-81969-02
49B	Burner Tube (STD)	228-39177-00	228-39177-00	228-39177-00	228-39177-00	228-39177-00	228-39177-00	228-39177-00	228-39177-00
	Burner Tube (Lo-NOx) ▲	228-42490-00	228-42490-00	228-42490-00	228-42490-00	228-42490-00	228-42490-00	228-42490-00	228-42490-00
49C	Burner Tube (Stainless Steel)	228-81964-00	228-81964-00	228-81964-00	228-81964-00	228-81964-00	228-81964-00	228-81964-00	228-81964-00
49D	Burner Shroud	239-42407-00	239-42407-00	239-42407-00	239-42407-00	239-42407-00	239-42407-00	239-42407-00	239-42407-00
49E	Burner Draft Panel	239-39420-00	239-39420-00	239-39420-00	239-39420-00	239-39420-00	239-39420-00	239-39420-00	239-39420-00
49F	Burner Support	239-45181-00	239-45181-00	239-45181-00	239-45181-00	239-45181-00	239-45181-00	239-45181-00	239-45181-00
49G	Aluminum Tubing	233-80361-09	233-80361-09	233-80361-09	233-80361-09	233-80361-09	233-80361-09	233-80361-09	233-80361-09
49H	Pilot Shield	239-41333-00	239-41333-00	239-41333-00	239-41333-00	239-41333-00	239-41333-00	239-41333-00	239-41333-00
49H	Pilot Orifice (Natural Gas)	233-41606-01	233-41606-01	233-41606-01	233-41606-01	233-41606-01	233-41606-01	233-41606-01	233-41606-01
	Pilot Orifice (LP Gas)	233-41606-02	233-41606-02	233-41606-02	233-41606-02	233-41606-02	233-41606-02	233-41606-02	233-41606-02
49J	Pilot Assembly (Natural Gas)	233-42013-01	233-42013-01	233-42013-01	233-42013-01	233-42013-01	233-42013-01	233-42013-01	233-42013-01
	Pilot Assembly (LP Gas)	233-42013-02	233-42013-02	233-42013-02	233-42013-02	233-42013-02	233-42013-02	233-42013-02	233-42013-02
50	Gas Valve Assembly (Natural Gas)	243-42780-03	243-42780-01	243-42780-05	243-42780-03	243-42780-04	243-42780-01	243-42780-05	243-42780-05
	Gas Valve Assembly (LP Gas)	243-42780-04	243-42780-02	243-42780-06	243-42780-06	243-42780-04	243-42780-02	243-42780-06	243-42780-06
50A	Street Elbow	239-20292-00	239-20292-00	239-20292-00	239-20292-00	239-20292-00	239-20292-00	239-20292-00	239-20292-00
50B	Gas Valve (Natural Gas)	222-80830-02	222-80830-02	222-80830-02	222-80830-02	222-80830-02	222-80830-02	222-80830-02	222-80830-02
	Gas Valve (LP Gas)	222-80831-02	222-80831-02	222-80831-02	222-80831-02	222-80831-02	222-80831-02	222-80831-02	222-80831-02
50C	Aluminum Tubing	233-80361-08	233-80361-08	233-80361-08	233-80361-08	233-80361-08	233-80361-08	233-80361-08	233-80361-08
50D	Nipple Close	239-05972-00	239-05972-00	239-05972-00	239-05972-00	239-05972-00	239-05972-00	239-05972-00	239-05972-00
50E	Union	239-41833-00	239-41833-00	239-41833-00	239-41833-00	239-41833-00	239-41833-00	239-41833-00	239-41833-00
	Nipple	239-31811-00	239-31811-00	239-31811-00	239-31811-00	239-31811-00	239-31811-00	239-31811-00	239-31811-00
50G	Flange Combustion Box	239-41612-00	239-41612-00	239-41612-00	239-41612-00	239-41612-00	239-41612-00	239-41612-00	239-41612-00
50H	Flange Gasket	239-41613-00	239-41613-00	239-41613-00	239-41613-00	239-41613-00	239-41613-00	239-41613-00	239-41613-00
50J	Manifold	233-41550-00	233-41550-00	233-41550-00	233-41550-00	233-41550-00	233-41550-00	233-41550-00	233-41550-00
50K	Main Burner Orifice (Natural Gas) (Off to 2000ft)	234-06016-81	234-06016-78	234-06016-41	234-06016-41	234-06016-81	234-06016-78	234-06016-41	234-06016-41
	High Altitude Orifice (Natural Gas) (2001ft to 5000ft)	234-06016-81	234-06016-79	234-06016-77	234-06016-77	234-06016-81	234-06016-79	234-06016-77	234-06016-77
	High Altitude Orifice (Natural Gas) (5001ft to 8000ft)	234-06016-81	234-06016-81	234-06016-78	234-06016-78	234-06016-81	234-06016-81	234-06016-78	234-06016-78
	High Altitude Orifice (Natural Gas) (8001ft & above)	234-06016-81	234-06016-81	234-06016-79	234-06016-79	234-06016-81	234-06016-81	234-06016-79	234-06016-79
	Main Burner Orifice LP Gas) (Off to 2000ft)	234-06016-55	234-06016-53	234-06016-52	234-06016-52	234-06016-55	234-06016-53	234-06016-52	234-06016-52
	High Altitude Orifice (LP Gas) (2001ft to 5000ft)	234-06016-55	234-06016-55	234-06016-52	234-06016-52	234-06016-55	234-06016-52	234-06016-55	234-06016-52
	High Altitude Orifice (LP Gas) (5001ft to 8000ft)	234-06016-55	234-06016-54	234-06016-52	234-06016-52	234-06016-55	234-06016-52	234-06016-55	234-06016-52
	High Altitude Orifice (LP Gas) (8001ft & above)	234-06016-55	234-06016-54	234-06016-52	234-06016-52	234-06016-55	234-06016-52	234-06016-55	234-06016-52
-	LP to NAT Conversion Kit	265-46035-01	265-46035-02	265-46035-03	265-46035-03	265-46035-01	265-46035-02	265-46035-03	265-46035-03

*Applies to all warranties

**Ordering a complete Burner Assembly may increase delivery time. Please order specific components for quickest delivery.

▲Applies when "E" is present in model number (example PDV80S150E3N)

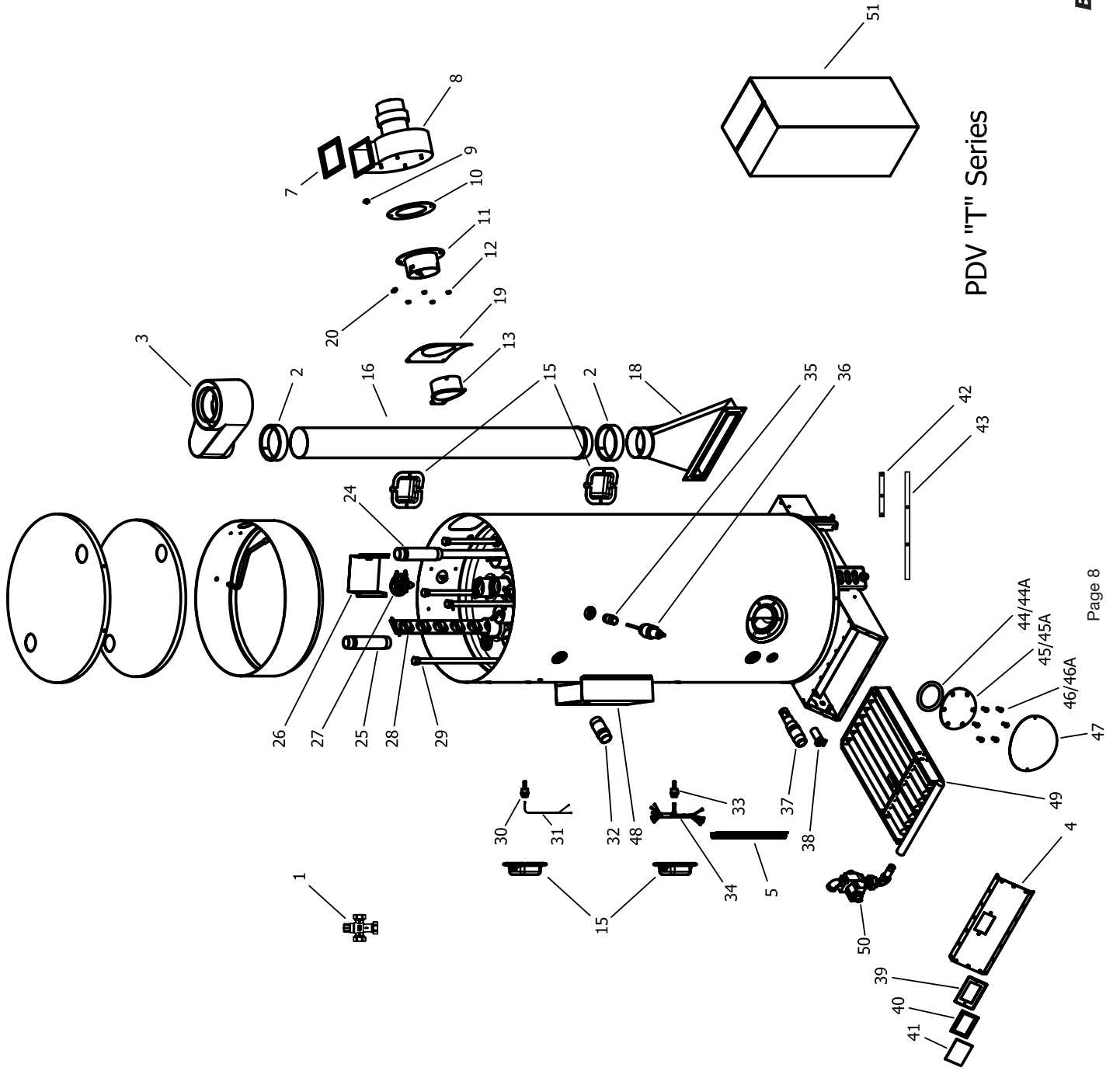

PDV "T" Series

Item	part description	Model	Model
		PDV80T300(E)*(N,X)(A)	PDV100T360(E)*(N,X)(A)
1	Mixing Valve (Optional)	239-43740-02	239-43740-02
2	Vent Clamp	239-42065-00	239-42065-00
3	Blower Vent Adaptor	239-41523-00	239-41523-00
4	Combustion Box Cover	239-41608-00	239-41608-00
5	Raceway Valve and Pilot Wires	239-41551-01	239-41551-02
7	Blower Receptacle Gasket	239-41549-00	239-41549-00
8	Blower	239-41503-00	239-41503-00
9	Temperature Switch	239-43238-03	239-43238-03
10	Blower Intake Gasket	239-81161-00	239-81161-00
11	Blower Mounting Flange	239-41525-00	239-41525-00
12	Nut 1/4-20 Hex	239-43297-00	239-43297-00
13	Collector to Blower Transition	239-41505-00	239-41505-00
15	Utility Cover	239-80281-03	239-80281-03
16	Air Intake Pipe	239-41590-01	239-41590-02
18	Combustion Box Boot	243-41576-00	243-41576-00
19	Blower Escutcheon	243-41524-00	243-41524-00
20	Blower Hose Barb	239-41553-00	239-41553-00
24	Cold Water Inlet Dip Tube (top)	229-43192-04	229-43192-05
25	Hot Water Outlet Nipple (top)	229-41573-01	229-41573-01
26	Cover Pressure Switch	239-41763-00	239-41763-00
27	Pressure Switch (Off to 5000ft)	239-44063-04	239-44063-02
	Pressure Switch High Altitude (Over 5000ft)	239-44063-03	239-44063-01
28	Flue Baffle	243-41455-00	243-41455-00
29	Anode Hex Head Magnesium	224-32758-24	224-32758-15
	Anode Hex Head Aluminum	224-38508-06	224-38508-03
30	Upper Thermostat Sensor	239-82033-00	239-82033-00
31	Wire Harness Upper Sensor	239-41569-00	239-41569-00
32	Hot Water Outlet Nipple (side)	229-41573-01	229-41573-01
33	Lower Thermostat Sensor	239-82034-00	239-82034-00
34	Wire Harness Lower Sensor	239-45363-00	239-45363-00
35	T/P nipple	239-80982-00	229-80982-00
36	T/P valve	230-33630-04	230-33630-04
37	Cold Water Inlet Dip Tube (side)	229-44731-00	229-44731-00
38	Drain Valve	265-42351-02	265-42351-02
39	Sight Glass Holder	239-42481-00	239-42481-00
40	Sight Glass Gasket	239-41635-00	239-41635-00
41	Sight Glass	239-41610-00	239-41610-00
42	Combustion Box Gasket - Sides	239-41626-00	239-41626-00
43	Combustion Box Gasket - Top & Bottom	239-41627-00	239-41627-00
44	Cleanout O-Ring	205-18427-00	205-18427-00
44A	Cleanout Gasket (ASME)	205-32942-00	205-32942-00
45	Cleanout Cover	205-18428-00	205-18428-00
45A	Cleanout Cover (ASME)	205-32942-00	205-32942-00
46	Screw 5/16-18 X 1/2 Hex	239-82166-00	239-82166-00
46A	Screw 5/16-18 X 1/2 Hex (ASME)	205-32942-00	205-32942-00
47	Cleanout Jacket Cover	243-20299-00	243-20299-00

*Applies to all warranties

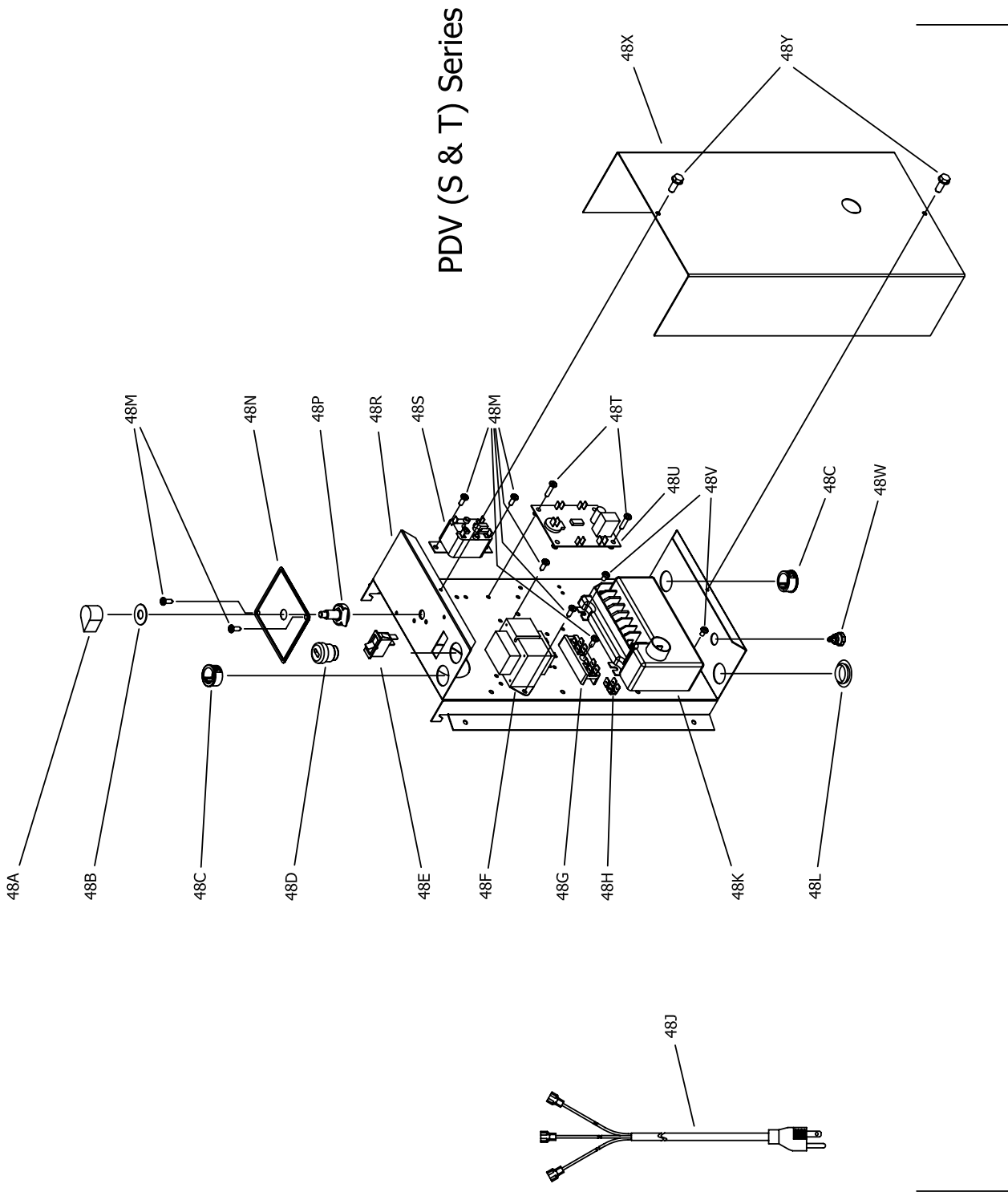

PDV (S & T) Series

Item	part description	Model	Model
48	Control Box Assembly**	PDV80T300(E)*(N,X)(A)	PDV100T360(E)*(N,X)(A)
48A	Potentiometer Knob	243-44580-01	243-44580-01
48B	Potentiometer Gasket	239-41710-00	239-41710-00
48C	Snap-In Bushing	223-82047-00	223-82047-00
48D	Bushing	239-80406-00	239-80406-00
48E	Power Switch	239-44575-00	239-44575-00
48F	Transformer	239-41566-00	239-41566-00
48G	Terminal Block	233-44072-01	233-44072-01
48H	Terminal Strip	239-80373-00	239-80373-00
48J	Power Cord	239-80112-00	239-80112-00
48K	Module	239-80377-00	239-80377-00
48L	Plug Plastic	233-43128-00	233-43128-00
48M	Screw #8-18 X .50	239-81415-05	239-81415-05
48N	Temperature Label	239-43736-00	239-43736-00
48P	Potentiometer	238-44588-00	238-44588-00
48R	Control Box Panel	233-82054-00	233-82054-00
48S	Relay Single Pole	239-44576-00	239-44576-00
48T	Screw #8-18 X .75	233-41560-00	233-41560-00
48U	Thermostat Board	239-43863-00	239-43863-00
48V	Screw #8-18 X .25	233-41347-00	233-41347-00
48W	Power Cord Bushing	239-43573-00	239-43573-00
48X	Control Box Cover	239-80372-00	239-80372-00
48Y	Screw 1/4-20 X .62 Hex Head	239-44563-00	239-44563-00
		239-42637-00	239-42637-00

*Applies to all warranties

**Ordering a complete Control Box Assembly may increase delivery time. Please order specific components for quickest delivery.

PDV "T" Series

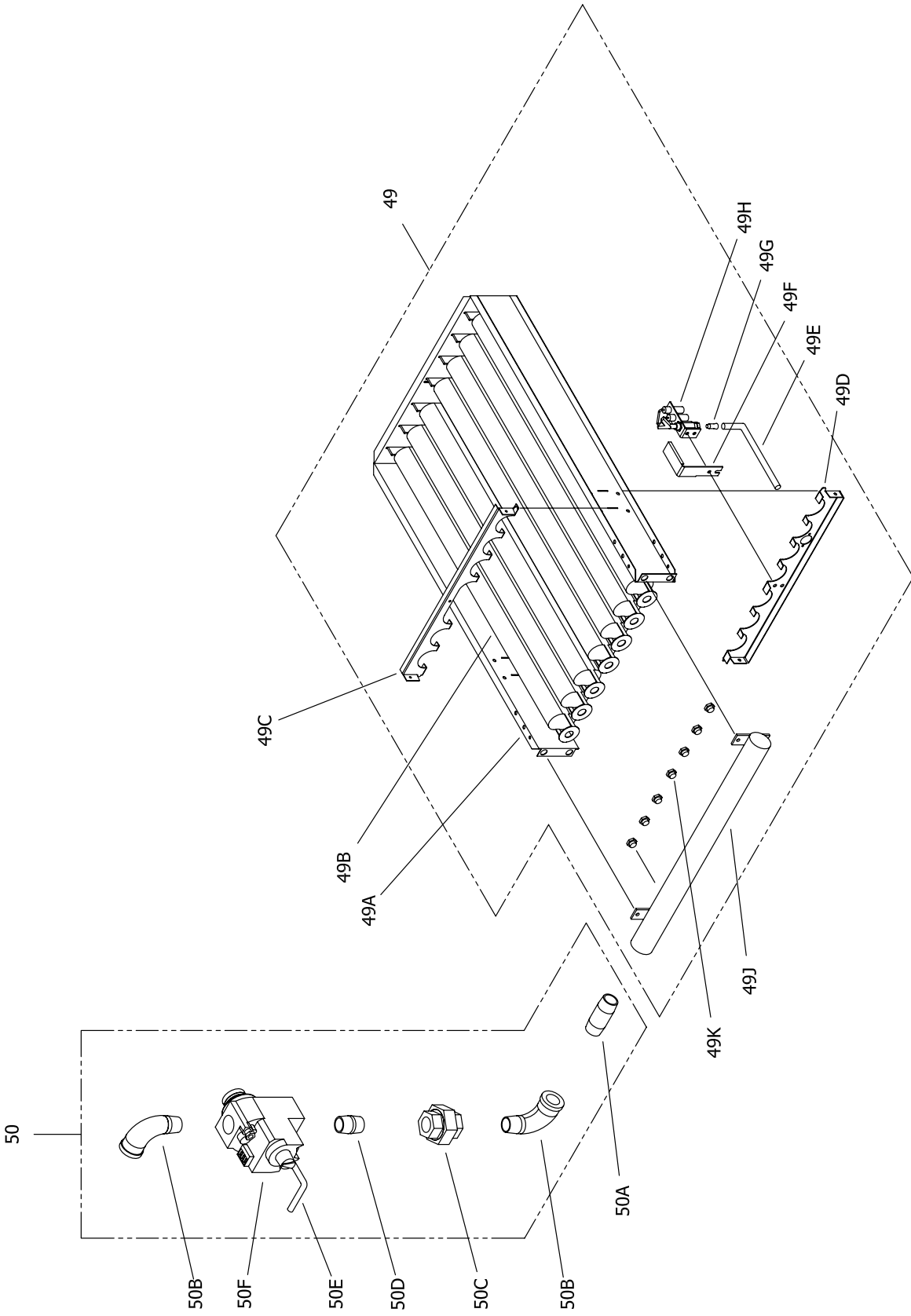

Item	part description	Model	Model
		PDV80T300(E)*(N,X)(A)	PDV100T360(E)*(N,X)(A)
49	Burner Assembly (Natural Gas)**	243-41468-07	243-41468-09
	Burner Assembly (Natural Gas) (Lo-NOx)** ▲	243-42955-01	243-42955-02
	Burner Assembly (LP Gas)**	243-41468-08	243-41468-10
49A	Burner Rack	239-81969-02	239-81969-02
49B	Burner Tube (STD)	228-39177-00	228-39177-00
	Burner Tube (Lo-NOx) ▲	228-42490-00	228-42490-00
	Burner Tube (Stainless)	228-81964-00	228-81964-00
49C	Burner Draft Panel	239-39420-00	239-39420-00
49D	Burner Support	239-45181-00	239-45181-00
49E	Aluminum Tubing	233-80361-09	233-80361-09
49F	Pilot Shield	239-41333-00	239-41333-00
49G	Pilot Orifice (Natural Gas)	233-41606-01	233-41606-01
	Pilot Orifice (LP Gas)	233-41606-02	233-41606-02
49H	Pilot Assembly (Natural Gas)	233-42013-01	233-42013-01
	Pilot Assembly (LP Gas)	233-42013-02	233-42013-02
49J	Manifold	233-41550-00	233-41550-00
49K	Main Burner Orifice (Natural Gas) (0ft to 2000ft)	234-06016-33	234-06016-31
	High Altitude Orifice (Natural Gas) (2001ft to 5000ft)	234-06016-33	234-06016-31
	High Altitude Orifice (Natural Gas) (5001ft to 8000ft)	234-06016-35	234-06016-32
	High Altitude Orifice (Natural Gas) (8001ft & above)	234-06016-35	234-06016-32
	Main Burner Orifice LP Gas) (0ft to 2000ft)	234-06016-49	234-06016-47
	High Altitude Orifice (LP Gas) (2001ft to 5000ft)	234-06016-49	234-06016-47
	High Altitude Orifice (LP Gas) (5001ft to 8000ft)	234-06016-50	234-06016-48
	High Altitude Orifice (LP Gas) (8001ft & above)	234-06016-50	234-06016-48
50	Gas Valve Assembly (Natural Gas)	243-41552-01	243-41552-01
	Gas Valve Assembly (LP Gas)	243-41552-02	243-41552-02
50A	Nipple	239-33557-00	239-31811-00
50B	Street Elbow	239-20292-00	239-20292-00
50C	Union	239-41833-00	239-41833-00
50D	Nipple Close	239-05972-00	239-05972-00
50E	Aluminum Tubing	233-80361-08	233-80361-08
50F	Gas Valve (Natural Gas)	222-80830-02	222-80830-02
	Gas Valve (LP Gas)	222-80831-02	222-80831-02
-	LP to NAT Conversion Kit	265-46035-04	265-46035-05

*Applies to all warranties
**Ordering a complete Burner Assembly may increase delivery time. Please order specific components for quickest delivery.
▲Applies when "E" is present in model number (example PDV80T300E3N)

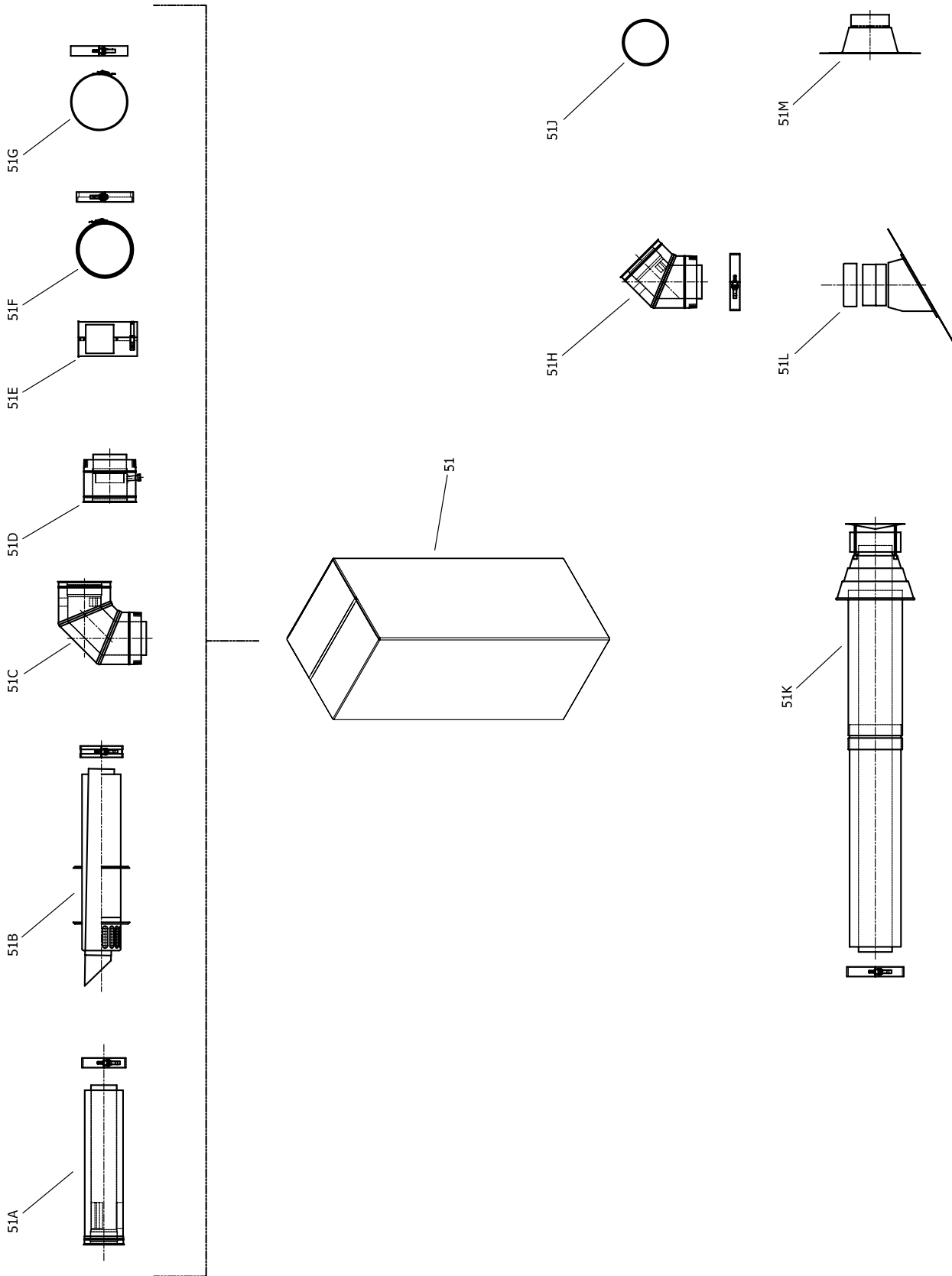

Item	part description	Model	
		PDV80T300(E)*(N,X)(A)	PDV100T360(E)*(N,X)(A)
51	Vent Kit	243-41769-01	243-41769-01
51A	Coaxial Tube 130/200 w/Clamp (2 per kit)	239-41593-00	239-41594-00
51B	Coaxial Vent Term. Vertical 130/200 w/Clamp	239-41589-00	239-41589-00
51C	Coaxial Vent Elbow 130/200	239-41584-00	239-41584-00
51D	Horz./Vert. Condensate Trap 130/200	239-41597-00	239-41597-00
51E	Cap Horizontal Vent Term. 130	239-41676-00	239-41676-00
51F	Vent Adaptor Clamp	239-41459-00	239-41459-00
51G	Vent Pipe Clamp 200	239-41629-00	239-41629-00
51H	Coaxial Vent Elbow 45° 130/200 w/Clamp (Optional)	239-41585-00	239-41585-00
51J	Silicone Seal 130 (Optional)	239-41595-00	239-41595-00
51K	Coax Vent Term. Vertical 130/200 w/Clamp (Optional)	239-41586-00	239-41586-00
51L	Roof Flashing Angled 200 (Optional)	239-41859-00	239-41859-00
51M	Roof Flashing 200 (Optional)	239-41678-02	239-41678-02

*Applies to all warranties



BRADFORD WHITE®

C O R P O R A T I O N

Ambler, PA

For U.S. and Canada field service,
contact your professional installer or
local Bradford White sales representative.

Sales/800-523-2931
Fax/215-641-1670
Parts Fax/215-641-2180

Technical Support/800-334-3393
Fax/269-795-1089

Warranty/800-531-2111
Fax/269-795-1089

International:
Telephone/215-641-9400
Telefax/215-641-9750



BRADFORD WHITE-CANADA® INC.

Mississauga, ON

Sales/866-690-0961
905-238-0100

Fax/905-238-0105

Technical Support/800-334-3393

Email

parts@bradfordwhite.com
techserv@bradfordwhite.com

www.bradfordwhite.com