



# SlimFit™

Commercial Condensing  
Gas-fired water boilers



## Boiler Manual

- Installation
- Maintenance
- Startup
- Parts



**WARNING**

This manual must only be used by a qualified heating installer/service technician. Read all instructions, including this manual and all other information shipped with the boiler, before installing. Perform steps in the order given. Failure to comply could result in severe personal injury, death or substantial property damage.

**DO NOT operate the boiler during construction** unless combustion air is piped to the boiler air inlet from a dust-free and contaminant-free area. The boiler can be severely damaged by drywall dust or other combustion air contaminants.

Part number 550-100-116/0913



## The SlimFit™ Commercial Condensing Water Boiler

### SlimFit model numbers:

**Left-hand boilers** (cleanout access on left side when facing burner end)

**SF1000L** — 1000 MBH input  
**SF1500L** — 1500 MBH input  
**SF2000L** — 2000 MBH input

**Right-hand boilers** (cleanout access on right side when facing burner end)

**SF1000R** — 1000 MBH input  
**SF1500R** — 1500 MBH input  
**SF2000R** — 2000 MBH input

### 1 Cast aluminum sectional heat exchanger

Heat exchanger can be supplied in left-hand or right-hand configuration. They CANNOT be field converted. They must be purchased as right or left.

Left-hand configuration — cleanout access and gas pipe on left side; supply and return pipes on right side.

Right-hand configuration — cleanout access and gas pipe on right side; supply and return pipes on left side.

### 2 Heat exchanger cleanout plate

### 3 Blower

Air enters through the air intake adapter, then enters the venturi. The blower pulls air and gas through the venturi and pushes the mixture into the burner. The advanced blower design and air inlet silencer yield very quiet operation.

### 4 Blower motor

### 5 Venturi

When air flows through the venturi, it creates a vacuum that is sensed by the gas valve to regulate gas flow.

### 6 Acoustic adapter (Model SF1000 only)

This adapter includes an acoustic chamber that minimizes combustion noise.

### 7 Sola control module

The Sola control module responds to inputs from system heating or DHW controls (or building management system), boiler sensors (boiler return, boiler supply, heat exchanger, system return, system supply, flue temperature, and outdoor temperature, if used). The control module automatically adjusts blower speed (and gas flow rate) to match boiler output to space heating and/or DHW heating demand. The Sola control module includes versatile programmability, allowing for:

Operation of boiler pump, DHW pump, system pump and others.

Lead/lag regulation of multiple SlimFit boilers.

Priority regulation for DHW, space heating or other loads.

### 8 Sola touch-screen LCD display

The color display provides graphics and multi-line text display. Information and programming functions are accessed via touch-screen navigation.

See configuration options on page 3 for orientation options.

### 9 Automatic gas valve

The automatic gas valve incorporates two solenoid-operated valve seats. The valve senses the vacuum in the venturi (item 5) caused by flowing air. Gas flows in proportion to air flow, so fuel/air ratio remains constant as blower speed/air flow changes.

### 10 Gas valve reference line

This line is used to measure the pressure of the incoming air to the venturi and adjust the combustion accordingly.

### 11 Electrical entrance snap-in covers

Knockouts are provided in the jacket top panel, allowing conduit entry above the low-voltage and line-voltage field wiring terminal strips.

### 12 Gas valve test cock

### 13 Terminal strips

### 14 ON/OFF switch

### 15 Reset switch

### 16 Blower relay

### 17 Minimum air flow relay

### 18 Transformer

### 19 Spark generator

### 20 High gas pressure switch

### 21 Low gas pressure switch

### 22 Flue pressure switch

### 23 Minimum air flow switch

### 24 Low water cutoff circuit board

### 25 Low water cutoff test switch

### 26 Low water cutoff reset switch

### 27 Low water cutoff probe (not shown)

The low water cutoff probe is mounted in a tapping in the right top corner of the burner end section.

### 28 Premix gas burner (not shown)

Made with high-grade stainless steel and fiber mesh construction, the burner uses pre-mixed air and gas. The burner and control provide modulating firing.

### 29 Ignition electrode and flame sensor (not shown)

The burner flame is ignited by applying a high voltage to the ignition electrode, located in the front section. This causes a spark (from electrode to ground). After ignition, the flame sensor electrode (not shown, located in the rear section) measures flame signal.

### 30 Flame inspection window

The quartz glass windows provides a view of the burner surface and flame (one located on each boiler end section).

### 31 Water outlet pipe (system supply) — 3" flanged

### 32 Water return pipe (system return) — 3" flanged

### 33 Gauge tapping

The pressure/temperature gauge is shipped loose for field installation in this tapping.

### 34 Relief valve tapping

The relief valve is shipped loose for field installation in this tapping.

### 35 Temperature sensor tapping — outlet temperature (not visible in the view shown)

The outlet sensor tapping is located on top of the outlet pipe, just outside the heat exchanger connection.

### 36 Temperature sensor tapping — return temperature (not visible in the view shown)

The return sensor tapping is located on top of the return pipe, just outside the heat exchanger connection.

### 37 Gas connection

### 38 Vent connection

Vent pipe connection, 10-inch nominal (9.85" I.D.). Installer must provide a vent/air pipe manufacturer's SlimFit Vent/Air Adapter to adapt to the vent pipe used. Where the manual allows vent pipe smaller than the adapter outlet, a reducer must also be provided by the installer.

### 39 Air intake connection

Air pipe connection, 10-inch nominal (9.85" I.D.). Installer must provide a vent/air pipe manufacturer's SlimFit Vent/Air Adapter to adapt to the air pipe used. Where the manual allows vent pipe smaller than the adapter outlet, a reducer must also be provided by the installer. Leave air connection open for inside air applications (direct exhaust).

### 40 Condensate trap assembly

### 41 Burner end access doors

The three access panels on the burner end are interchangeable. This allows location of the Sola display on either the front side or burner end of the boiler.

### 42 Piping end access doors

The three access panels on the piping end are removable for access and servicing.

### 43 Electrical access panel

### 44 Casters (used for locating boiler only)

### 45 Mounting legs (extended after boiler is in position)



The **SlimFit™** Commercial Condensing Water Boiler (Model SF1000 shown)

**Configuration options**

(Order boiler as left-hand or right-hand)

**Left-hand (suffix L)**

- Cleanout panel access is on the left side when viewed from the burner end.
- Control display is factory-mounted on front (cleanout access side), but can be field relocated on burner end as instructed in this manual.

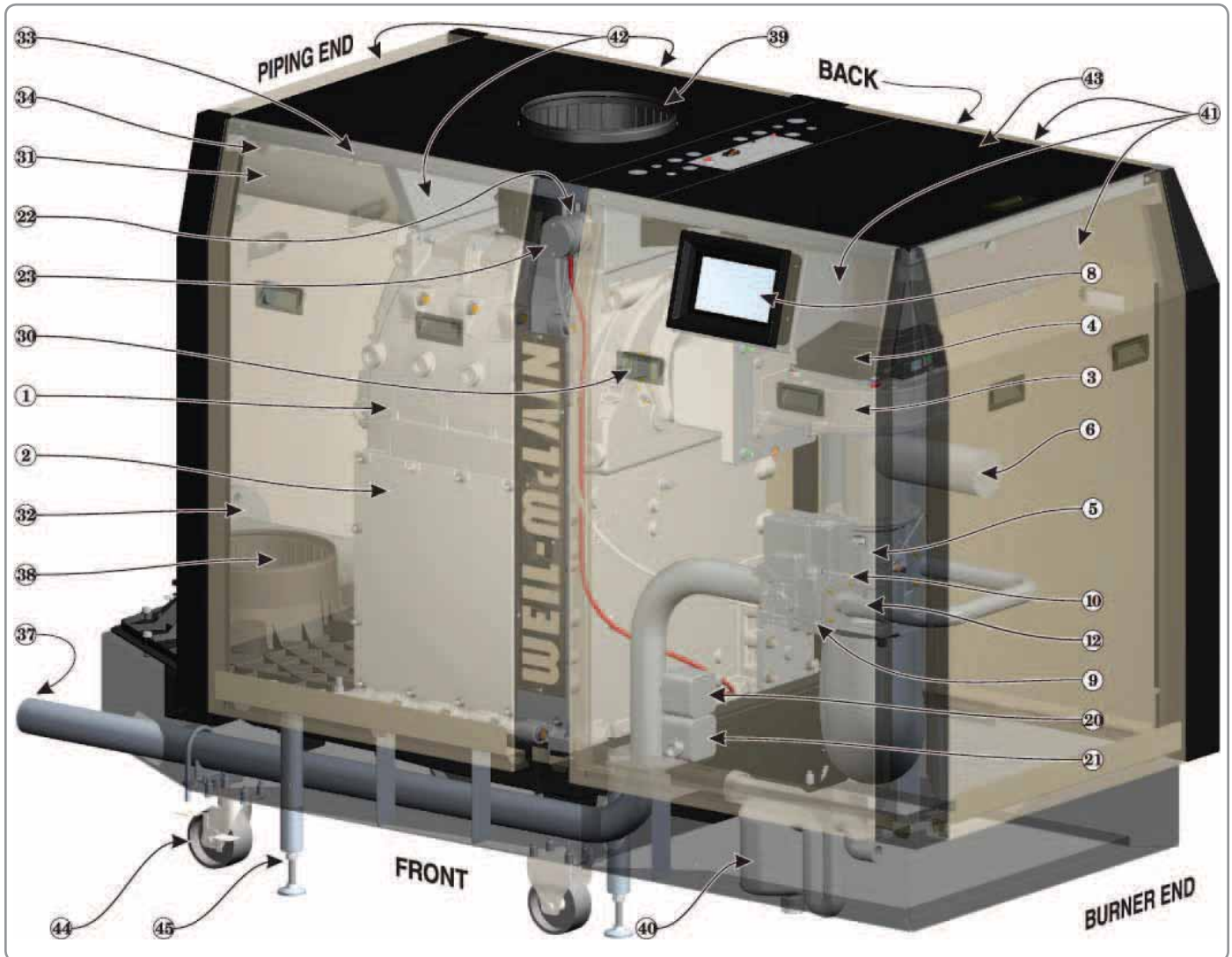
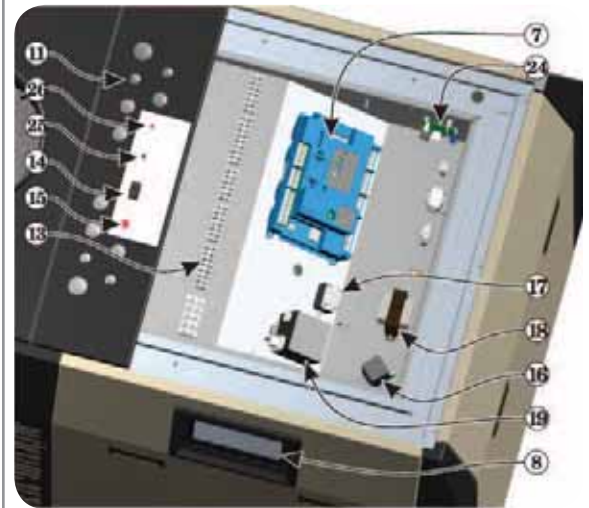


**Right-hand (suffix R)**

- Cleanout panel access is on the right side when viewed from the burner end.
- Control display is factory-mounted on front (cleanout access side), but can be field relocated on burner end as instructed in this manual.



**Electrical panel components**





# Contents

Contents . . . . . 4

Hazard definitions . . . . . 4

Please read before proceeding . . . . . 5

Prepare boiler location . . . . . 6

Prepare boiler . . . . . 10

Install water piping . . . . . 14

Multiple boiler water piping . . . . . 22

Venting/combustion air — general . . . . . 28

Venting/combustion air — options . . . . . 29

Appliances remaining on an existing vent system . 32

Venting/air piping — Massachusetts installations . 33

DIRECT EXHAUST — Boiler room air openings . . 34

DIRECT EXHAUST — Termination location . . . . 36

DIRECT EXHAUST — Sidewall . . . . . 37

DIRECT EXHAUST — Vertical. . . . . 39

DIRECT VENT — Boiler room air openings . . . . 40

DIRECT VENT — Termination location . . . . . 42

DIRECT VENT — Sidewall . . . . . 43

DIRECT VENT — Vertical. . . . . 45

Install condensate components. . . . . 48

Gas piping . . . . . 49

Gas train diagram . . . . . 50

Field wiring (see Figure 56 & Figure 57) . . . . 51

Sola control overview & sequence of operation . . 58

**⚠ WARNING** DO NOT START THIS BOILER without following all instructions and procedures specified in the following sections:  
 “Startup — fill the system” on page 87  
 “Startup — final checks” on page 89  
 “Startup procedure” on page 90.

Failure to follow the instructions in this manual could result in severe personal injury, death or substantial property damage.

Sola control interface and menus . . . . . 60

Sola control express setup — single boiler . . . . 68

Sola control express setup — multiple boilers. . . 70

Sola control parameter table . . . . . 72

Startup — fill the system . . . . . 87

Startup — final checks . . . . . 89

Startup procedure . . . . . 90

Sola Information and Operations screens . . . . . 94

Annual startup and maintenance schedule . . . . 96

Annual startup. . . . . 97

Troubleshooting . . . . . 103

Maintenance. . . . . 112

Replacement parts . . . . . 115

Dimensions . . . . . 124

Ratings — SlimFit boilers . . . . . 126

Installation and Service Certificate . . . . . 128

# Hazard definitions

The following defined terms are used throughout this manual to bring attention to the presence of hazards of various risk levels or to important information concerning the life of the product.

**⚠ DANGER** Indicates presence of hazards that will cause severe personal injury, death or substantial property damage.

**⚠ CAUTION** Indicates presence of hazards that will or can cause minor personal injury or property damage.

**⚠ WARNING** Indicates presence of hazards that can cause severe personal injury, death or substantial property damage.

**NOTICE** Indicates special instructions on installation, operation or maintenance that are important but not related to personal injury or property damage.



## Please read before proceeding

**⚠ WARNING**

**Installer**— Read all instructions, including this manual and all other information shipped with the boiler, before installing. Perform steps in the order given.

**User** — This manual is for use only by a qualified heating installer/service technician. Refer to User's Information Manual for your reference.

**User** — Have this boiler serviced/inspected by a qualified service technician, at least annually.

Failure to comply with the above could result in severe personal injury, death or substantial property damage.

**NOTICE**

Write in the CP number in the space provided on the Installation certificate on page 128 if not already shown.

When calling or writing about the boiler— Please have the boiler model number from the boiler rating label and the CP number from the boiler jacket.

Consider piping and installation when determining boiler location.

Any claims for damage or shortage in shipment must be filed immediately against the transportation company by the consignee.

**⚠ DANGER**

**If any part of a boiler, burner or its controls has been sprayed with or submerged under water, either partially or fully, DO NOT attempt to operate the boiler until the boiler has been either replaced or completely repaired, inspected, and you are sure that the boiler and all components are in good condition and fully reliable.** Otherwise, by operating this boiler, you will cause a fire or explosion hazard, and an electrical shock hazard, leading to serious injury, death, or substantial property damage. See the instructions at right.

**Saltwater Damage** — The exposure of boiler components to saltwater can have both immediate and long-term effects. While the immediate effects of saltwater damage are similar to those of freshwater (shorting out of electrical components, washing out of critical lubricants, etc.), the salt and other contaminants left behind can lead to longer term issues after the water is gone due to the conductive and corrosive nature of the salt residue. Therefore, Weil-McLain equipment contaminated with saltwater or polluted water will no longer be covered under warranty and should be replaced.

**Electrical Damage** — If any **electrical component or wiring** came into contact with water, or was suspected to have come into contact with water, replace the boiler with a new Weil-McLain boiler.

**⚠ WARNING**

**Failure to adhere to the guidelines below can result in severe personal injury, death or substantial property damage.**

**When servicing boiler —**

- To avoid electric shock, disconnect all electrical supplies to the boiler before performing maintenance.
- To avoid severe burns, allow boiler to cool before performing maintenance.
- This boiler contains ceramic fiber and fiberglass materials. Refer to the WARNING and instructions on page 97.

**Boiler operation —**

- Do not block flow of combustion or ventilation air to boiler.
- Should overheating occur or gas supply fail to shut off, do not turn off or disconnect electrical supply to pump. Instead, shut off the gas supply at a location external to the appliance.

**Boiler water —**

- The SlimFit heat exchanger is made of aluminum, and requires that system pH always be between 7.0 and 8.5 and water chemistry be checked. **Chemical treatment is required. See page 87 for details.**
- **Thoroughly flush the system** (without boiler connected) to remove sediment. **Install a strainer or other sediment removal equipment** if necessary. The high-efficiency heat exchanger can be damaged by build-up or corrosion due to sediment.
- Do not use petroleum-based cleaning or sealing compounds in boiler system. Gaskets and seals in the system may be damaged. This can result in substantial property damage.
- Continual fresh make-up water will reduce boiler life. Mineral buildup in

heat exchanger reduces heat transfer, overheats the aluminum heat exchanger, and causes failure. Addition of oxygen carried in by make-up water can cause internal corrosion. Leaks in boiler or piping must be repaired at once to prevent make-up water. Use this boiler **ONLY** in a closed-loop system.

- Do not add cold water to a hot boiler. Thermal shock can cause heat exchanger to crack.

**Freeze protection fluids —**

**NEVER** use automotive or standard glycol antifreeze, even glycol made for hydronic systems. Use only freeze-protection fluids recommended in this manual (see page 87). Follow all guidelines given. Thoroughly clean and flush any replacement boiler system that has used glycol before installing the new SlimFit boiler.

**Commonwealth of Massachusetts**

When the boiler is installed within the Commonwealth of Massachusetts:

- This product must be installed by a licensed plumber or gas fitter.
- If antifreeze is used, a reduced pressure back-flow preventer device shall be used.
- Sidewall vent air installations — see instruction on page 33.



# Prepare boiler location

## Installations must comply with:

- Local, state, provincial, and national codes, laws, regulations and ordinances.
- National Fuel Gas Code, ANSI Z223.1/NFPA54 – latest edition.
- Standard for Controls and Safety Devices for Automatically Fired Boilers, ASME CSD-1, when required.
- National Electrical Code.
- For Canada only: CAN/CSA B149.1 Installation Code, CSA C22.1 Canadian Electrical Code Part 1 and any local codes.

**NOTICE**

The SlimFit boiler gas manifold and controls met safe lighting and other performance criteria when boiler underwent tests specified in ANSI Z21.13 — latest edition.

## Before locating the boiler, check:

1. Check for nearby connection to:
  - System water piping
  - Venting connections
  - Gas supply piping
  - Electrical power
  - Location of drain for condensate
2. Check area around boiler. Remove any combustible materials, gasoline and other flammable liquids.

**WARNING**

Failure to keep boiler area clear and free of combustible materials, gasoline and other flammable liquids and vapors can result in severe personal injury, death or substantial property damage.

3. The SlimFit boiler must be installed so that gas control system components are protected from dripping or spraying water or rain during operation or service.
4. If new boiler will replace existing boiler, check for and correct system problems, such as:
  - System leaks causing oxygen corrosion or heat exchanger cracks from hard water deposits.
  - Incorrectly-sized expansion tank.
  - Lack of freeze protection in boiler water causing system and boiler to freeze and leak.

## Flooring and foundation

### Flooring

5. The SlimFit boiler is approved for installation on combustible flooring, but must never be installed on carpeting.

**WARNING**

Do not install boiler on carpeting even if foundation is used. Fire can result, causing severe personal injury, death or substantial property damage.

### Foundation

1. The boiler mounting surface must be level and suitable for the load.
2. Provide a solid foundation pad, at least 2 inches above the floor, if any of the following is true:
  - floor can become flooded.
  - the floor is dirt, sand, gravel or other loose material.
  - the boiler mounting area is severely uneven or sloped.
3. The minimum foundation size is listed in Figure 1.
4. Foundation may be of wood, brick or concrete (minimum 2 inches thick) construction.
5. If flooding is possible, elevate boiler sufficiently to prevent water from reaching boiler.

**Figure 1** Minimum foundation size

Boiler model	Minimum size (inches)
SF1000	33 × 75
SF1500	33 × 75
SF2000	33 × 87

## Garage installation

### Precautions

1. Take the following special precautions when installing the boiler in a garage. If the boiler is located in a garage:
  - Mount the boiler at a height above the floor as specified in the National Fuel Gas Code, ANSI Z223.1/NFPA54 for U. S. installations, or CAN/CSA B149.1 for Canadian installations.
  - Locate or protect the boiler so it cannot be damaged by a moving vehicle.
  - Ensure that the installation complies with all applicable codes.



# Prepare boiler location *(continued)*

## Clearance requirements

### Clearances from combustible materials

1. Hot water pipes — at least 1/2" from combustible materials.
2. Vent pipe — at least 3/16" from combustible materials.
3. See Figure 2 for other clearance minimums.

### Clearances for service access

1. See Figure 2 for recommended service clearances. If you do not provide minimum clearances shown, it might not be possible to service the boiler without removing it from the space.



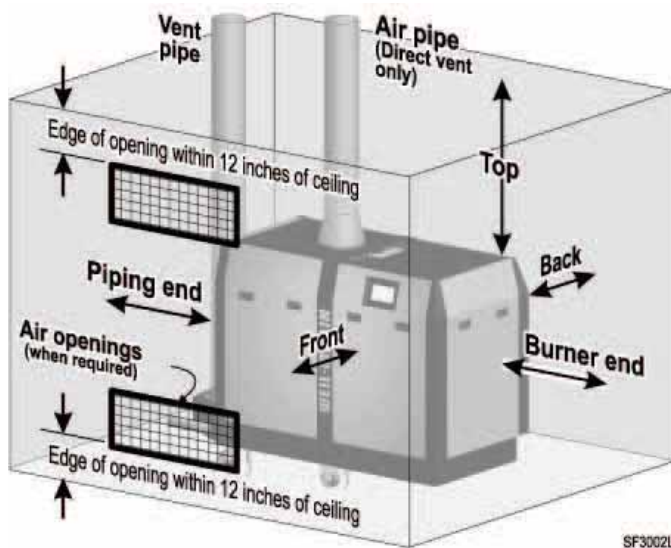
Openings in floors, walls, ceilings or roofs must be designed for fire stopping as required by local codes. Vent pipe openings through combustible materials must be 3/8" larger in diameter than the vent pipe. Air pipe openings should be 3/8" larger in diameter than the pipe or as required by the pipe manufacturer.

## Air openings



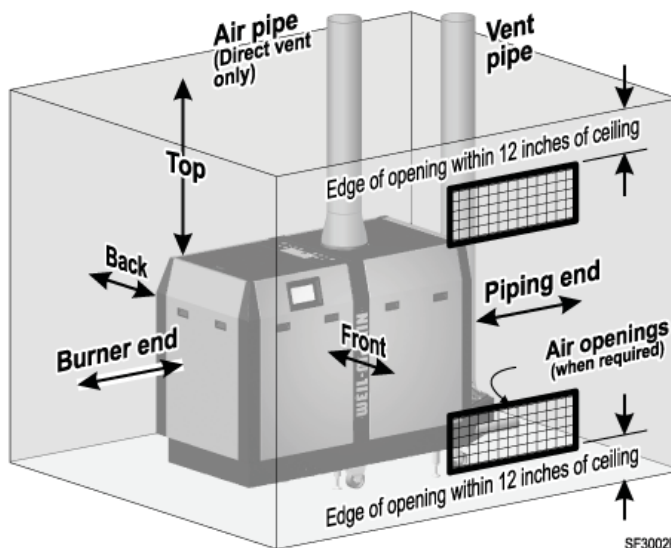
Provide air openings for combustion air and/or ventilation of the room as specified in this manual and as required by applicable codes.

**Figure 2** Clearances for LEFT-HAND boilers



Clearance from:	Minimum clearance to combustible surfaces (inches)	Minimum service access clearances (inches)
Front (cleanout side)	0	36
Back	0	0
Burner end	0	24
Piping end	0	12
Top	4	18
Floor	0	—
Vent pipe	3/16	—
Hot water pipes	1/2	—

**Figure 3** Clearances for RIGHT-HAND boilers



Clearance from:	Minimum clearance to combustible surfaces (inches)	Minimum service access clearances (inches)
Front (cleanout side)	0	36
Back	0	0
Burner end	0	24
Piping end	0	12
Top	4	18
Floor	0	—
Vent pipe	3/16	—
Hot water pipes	1/2	—



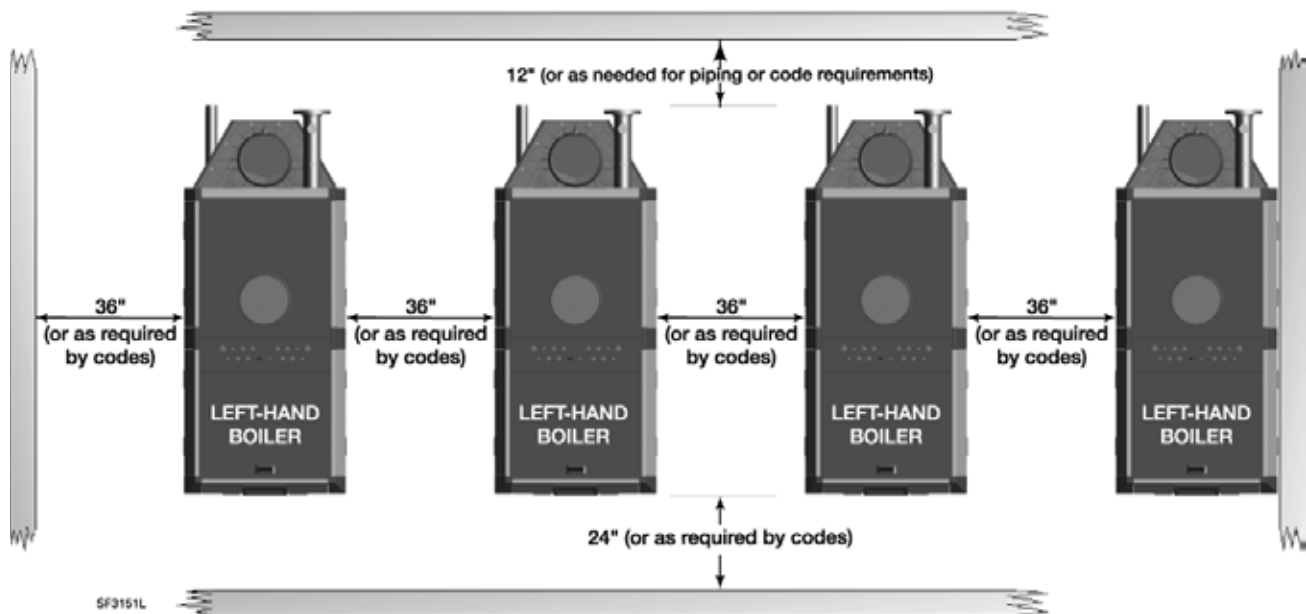
# Prepare boiler location *(continued)*

**NOTICE** Verify that boiler placement and clearances comply with all applicable codes.

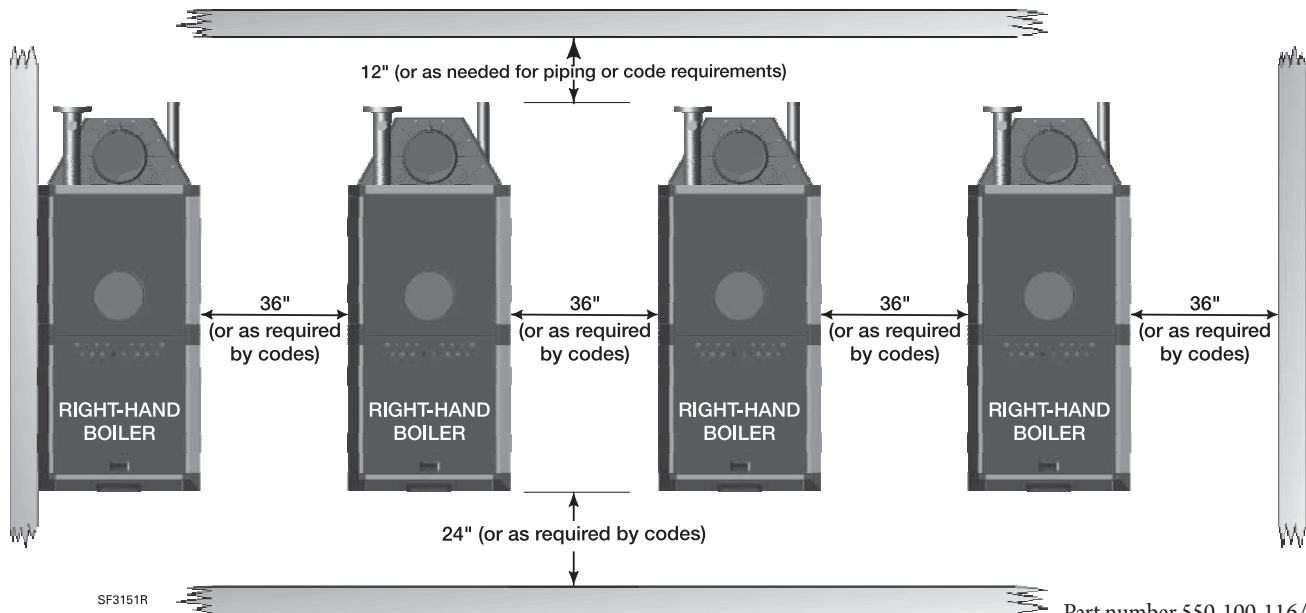
## Placing multiple boilers

1. Locate multiple boilers in boiler room to provide the clearances shown in:
  - a. Figure 4 (side-to-side), or
  - b. Figure 6 (mirror-image mounting).
  - c. Other layouts can be used if all required clearances are maintained.
2. Provide indicated clearances around boilers for access and servicing. If recommended dimensions are not possible, provide at least the minimum clearances given on page 7. Also follow local codes.
3. Construct boiler foundation if boiler room floor is uneven or if there is a danger of flooding. Size foundation to allow for clearance and spacing dimensions shown in either Figure 4 or Figure 6.
4. Chalk-line boiler locations on foundation or boiler room floor.
5. Uncrate, assemble and mount boilers according to instructions in this manual.
6. Provide clearance for installation of venting, air piping, gas piping, condensate piping and components, expansion tank, boiler pump and other accessories.

**Figure 4** Side-to-side mounting of multiple SlimFit boilers — LEFT-HAND boilers only



**Figure 5** Side-to-side mounting of multiple SlimFit boilers — RIGHT-HAND boilers only



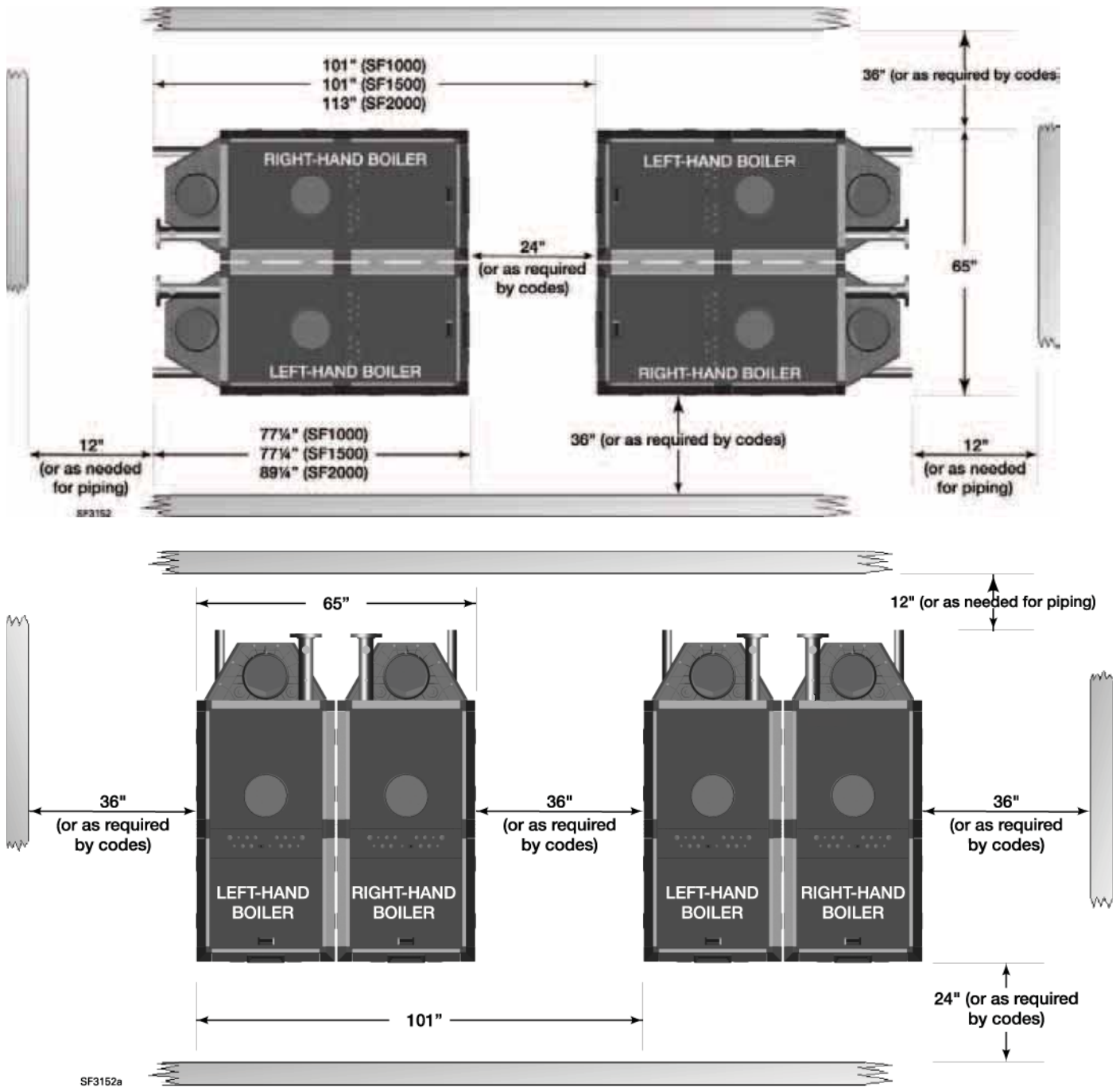




# Prepare boiler location *(continued)*

**NOTICE** Verify that boiler placement and clearances comply with all applicable codes.

**Figure 6** Side-by-side installation of multiple SlimFit boilers (using left-hand and right-hand boilers together)





# Prepare boiler

## Provide air openings to room

### Air openings — General

Follow the National Fuel Gas Code (U. S.) or CAN/CSA B149.1 (Canada) and all applicable codes to size/verify size of the combustion/ventilation air openings into the space. See the venting instructions section of this manual for required air openings and sizing for either direct vent or direct exhaust installation.

### Air openings — SlimFit boiler alone in boiler room

- 1. DIRECT VENT** — For direct vent installations (air piped to boiler), no air ventilation openings into boiler room are needed if clearances around the SlimFit boiler are at least equal to the SERVICE clearances shown in Figure 2, page 7. For spaces that DO NOT supply the minimum service access clearances, see the direct vent venting instructions in this manual for required openings.
- 2. DIRECT EXHAUST** — For direct exhaust installations (combustion air from inside), provide air openings as specified in the direct exhaust venting section of this manual.

### Air openings — SlimFit boiler in same room with other gas or oil-fired appliances

- 1. DIRECT VENT** — For direct vent installations (combustion air piped to boiler), size openings only on the basis of the other appliances in the space. No additional air opening free area is needed for the SlimFit boiler because it takes its combustion air from outside.

**▲WARNING** For direct vent installations, when the SlimFit boiler is located in the same room as other appliances, provide combustion air openings correctly sized for all appliances in the room except the SlimFit boiler.

Failure to comply with the above warnings could result in severe personal injury, death or substantial property damage.

- 2. DIRECT EXHAUST** — For direct exhaust installations, combustion air openings into the room must be sized to handle the SlimFit boiler and all other appliances. See the direct exhaust venting instructions in this manual for required openings.

#### ▲WARNING

**Direct exhaust installations** — On direct exhaust installations, the boiler draws combustion air from the boiler room. If other appliances are installed in the same room, provide combustion air openings correctly sized for **ALL** appliances, including the SlimFit boiler.

Failure to comply with the above warnings could result in severe personal injury, death or substantial property damage.

## Vent and air piping requirements (page 28)

- The SlimFit boiler requires a special vent system, designed for pressurized venting.
  - SlimFit boilers are rated ANSI Z21.13 Category IV (pressurized vent, likely to condense in the vent).
  - SlimFit commercial boilers can be either:
    - Direct-exhaust** — vent to the outside, combustion air from inside or . . .
    - Direct-vent** — both vent and air piped outside.
  - See instructions beginning on page 28 for vent/air configuration options and installation requirements.
- Note “Prevention of combustion air contamination” on page 29 when considering vent/air terminations and boiler room conditions when using inside air (direct exhaust installation).
- Be sure to locate the boiler such that the vent and air piping can be routed through the building and properly terminated. The vent/air piping lengths, routing and termination method must all comply with the methods and limits in instructions beginning on page 29.



## Prepare boiler *(continued)*

**CAUTION** **Cold weather handling** — If boiler has been stored in a very cold location (below 32°F) before installation, handle with care until the plastic components come to room temperature.

**WARNING** **The boiler is heavy.** Use caution not to drop the boiler or cause bodily injury while lifting and handling.

**WARNING** **Boiler supply, return and gas pipes** — Do not lift or handle the boiler by the water or gas pipes. Do not push on or apply weight to the pipes. Severe damage can be done to the boiler.

**CAUTION** Leave the **plastic covers** on the supply and return flanges and on the boiler vent and air adapters until ready to attach piping. This will protect the flanges surfaces from damage and prevent debris from falling into the vent or air adapter.

### Uncrating the boiler

**WARNING** Do not drop the boiler. Damage to boiler components can result. Leave the boiler on the crate pallet until ready to place in final location. Follow all uncrating instructions.

Failure to comply could result in severe personal injury, death or substantial property damage.

1. See Figure 8 for the following.
2. Move the crate to a solid, level surface.
3. There must be room at the piping end to place the ramp and roll the boiler down off the crate pallet.
4. Make sure the crate is sitting securely.
5. Remove outer cardboard covering.
6. Remove the ramp from the crate and place the end of the ramp into the notch in the pallet as shown in Figure 8.
7. Follow the uncrating instruction label to secure the ramp to the pallet.
8. Remove the sheet metal screws and lag bolts from the six shipping brackets. Remove and discard the shipping brackets. Re-insert the upper screws into the holes in the boiler frame for best appearance.

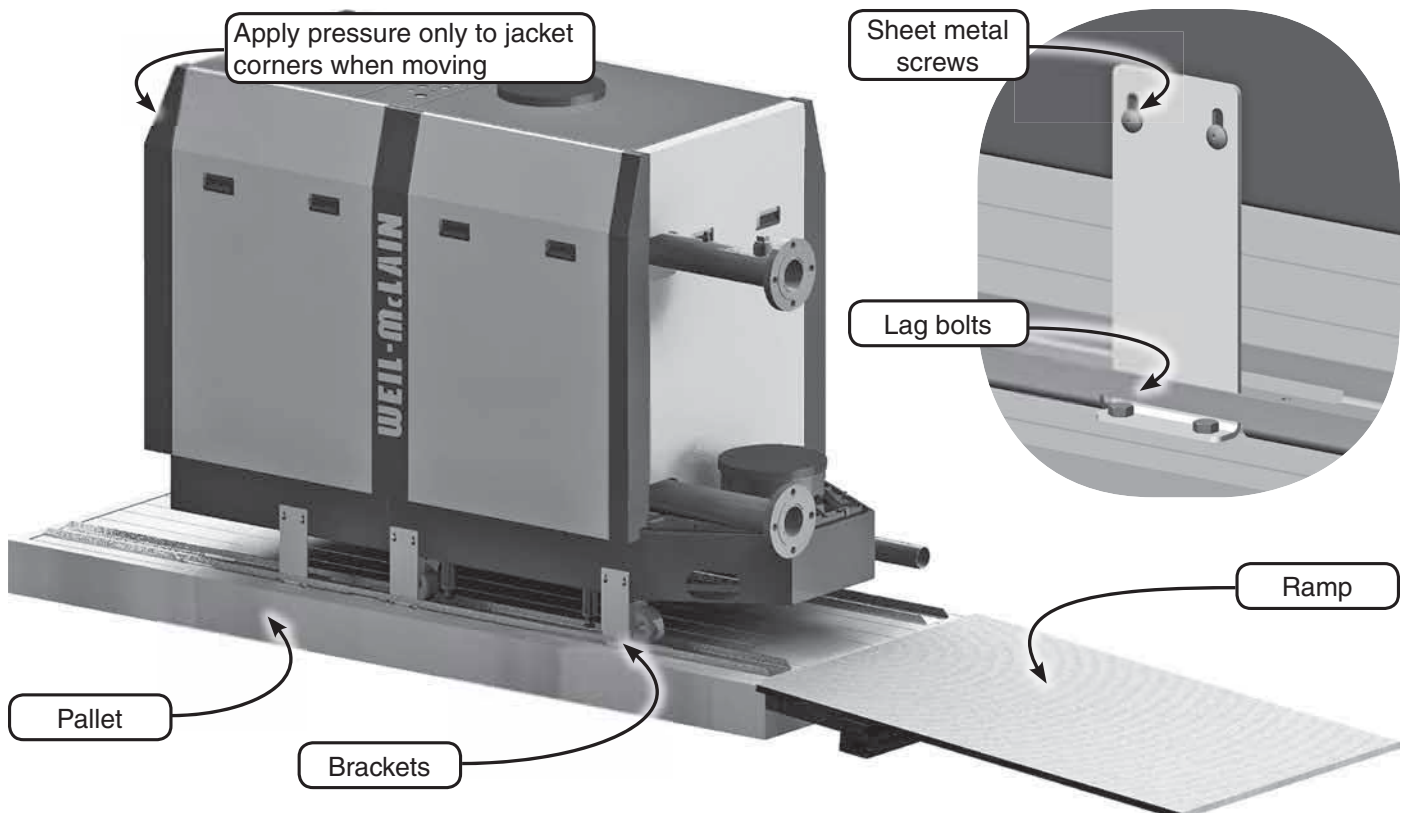
### Moving/handling the boiler

**WARNING** When moving the boiler, apply pressure **ONLY** at the jacket corner posts.

**DO NOT** use the piping or other extensions to manipulate the boiler.

Failure to comply could damage the boiler heat exchanger or other components.

**Figure 8** SlimFit boiler on pallet, with ramp in position



## Prepare boiler *(continued)*

### Placing the boiler

1. Roll the boiler down the ramp and move the boiler into position. Use only the jacket corner posts to manipulate the boiler.
2. The piping end casters are swivel type. The burner end casters are fixed.
3. Adjust the leveling legs down until they are firmly in contact with the floor.
4. Continue adjusting the legs down until all the bottom of the boiler base is 5¼ inches above the floor.



5. Check level. Extend mounting legs further as needed until the boiler is level.

**CAUTION** The boiler should not be allowed to rest on the casters. These are intended for moving the boiler into position only. The support legs must be extended to take the load of the boiler.

### Bolting the boiler to mounting blocks

1. For applications requiring that the boiler be bolted down (such as earthquake zone requirements), remove the casters and bolt the boiler base to mounting blocks using the existing holes in the base.
2. See Figure 9 for details.

**CAUTION** The mounting blocks must position the boiler with at least 5¼ inches between the bottom of the boiler base and the floor.

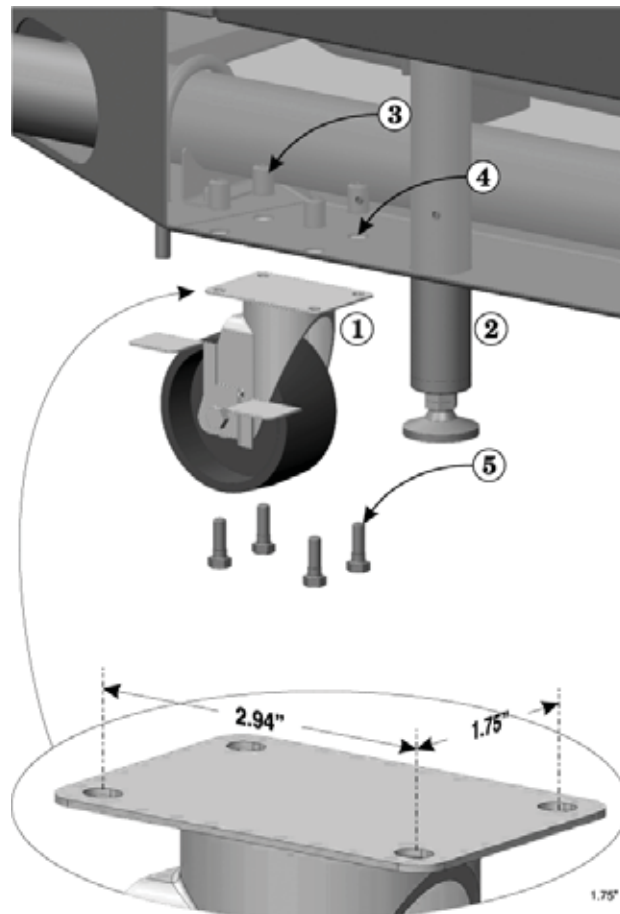
**WARNING** Follow all applicable codes and recognized engineering design practices to verify that the final mounting will meet all seismic, structural and other requirements.

### Boiler relief valve and P/T gauge

**WARNING** **DO NOT install a relief valve with a pressure higher than 100 PSIG.** This is the maximum allowable relief valve setting for the SlimFit boiler. The boiler is shipped with a 30 PSIG relief valve. See Replacement parts in the back of this manual for alternate pressure setting relief valves.

**NOTICE** The boiler is shipped with a ¼" NPT pressure and temperature gauge which has a pressure range up to 75 psig. This gauge meets ASME requirements up to a relief valve setting of 50 psig. For higher pressure rated relief valves, a different pressure and temperature gauge with a higher pressure range is required. When installing a gauge that requires a larger tapping than the ¼" NPT tapping in the boiler supply manifold, provide an additional tapping in the near boiler piping BEFORE any isolation valve.

**Figure 9** Removing the casters to allow bolting the boiler to mounting blocks



### Perform hydrostatic pressure test

Pressure test boiler before permanently attaching water or gas piping or electrical supply.

**NOTICE** Weil-McLain hydrostatically pressure tests each SlimFit boiler in the factory to 1½ times maximum allowable working pressure per ASME Section IV requirements.

A pressure test should be performed on site to 1½ times the pressure setting of the relief valve to be installed on the unit (45 psig for a 30-psig relief valve; 75 psig for a 50-psig relief valve; or 150 psig for a 100-psig relief valve).

### Prepare boiler for pressure test

1. See Figure 10, page 13 for reference in following steps. Use pipe dope sparingly.
2. At the boiler supply and return flanges, temporarily attach a 3-inch ANSI blind flange with tapping for a nipple and valve as shown (flanges, valves, gaskets nipples supplied by installer).



## Prepare boiler *(continued)*

3. Attach a water supply and hand pump to the lower valves.
4. Attach a drain line to the upper valve.
5. Remove the pressure & temperature gauge from the trim box shipped with the boiler.
6. Remove the factory-installed plug from the ½-inch tapping on top of the boiler supply pipe.
7. Apply pipe dope to the P/T gauge and install in the ¼" tapping as shown.

### Fill boiler and pressure test

1. Open the shutoff valves installed on the supply and return connections.
2. Allow water to flow into the bottom connection and air to flow out the top connection.
3. When water reaches the shutoff valve on top, allow water to flow long enough to ensure all air is out of the heat exchanger. Then close the upper shutoff valve.
4. Close off the water supply and use the hand pump to raise the water pressure for testing.
5. The test pressure should be 1½ times the pressure setting of the relief valve to be installed on the boiler (45 psig for a 30-psig relief valve; 75 psig for a 50-psig relief valve; or 150 psig for a 100-psig relief valve).

**▲WARNING** The test pressure **MUST NOT** exceed the maximum pressure on the P/T gauge. If test pressure will be higher than the maximum range of the P/T gauge, use a different gauge for the test.

6. Gradually apply pressure until test pressure is reached. Then close off the shutoff valve.
7. Hold at test pressure for 10 minutes.

**▲WARNING** Do not leave boiler unattended. A cold water fill could expand and cause excessive pressure, resulting in severe personal injury, death or substantial property damage.

8. Make sure that constant gauge pressure has been maintained throughout test.
9. Check for leaks. Repair if found.

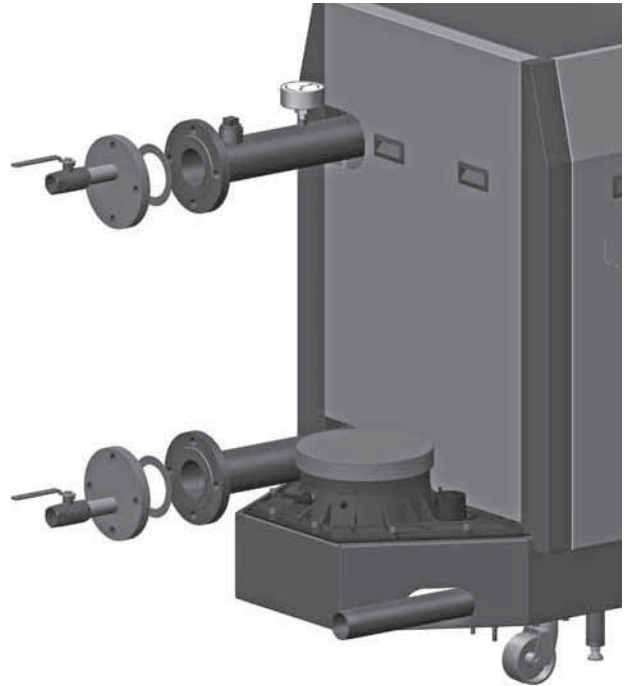
**▲WARNING** **Leaks must be repaired at once.** Failure to do so can damage boiler, resulting in substantial property damage.

**▲WARNING** **Do not use petroleum-based** cleaning or sealing compounds in boiler system. Gaskets and seals in the system may be damaged. This can result in substantial property damage.

### Drain and remove fittings

1. Disconnect fill water hose from water source.
2. Open upper shutoff valve.
3. Drain boiler through lower shut-off valve.
4. Remove hose or drain piping after draining.
5. Remove the blanking flange/valve assemblies from the boiler supply and return flanges.
6. See page 14 to install relief valve in the ¼" tapping on top of the boiler outlet pipe.

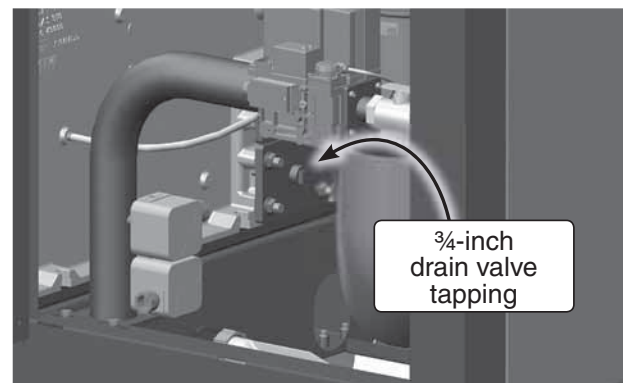
**Figure 10** Hydrostatic test piping connections — flanges, valves and gaskets provided by installer



### Boiler drain valve *(provided by installer)*

1. If not installing a drain valve off of the return piping, install a ¾-inch boiler drain valve in the ¾-inch tapping at the lower right burner end of the heat exchanger (see Figure 7).

**Figure 7** Boiler drain valve tapping — optional location for drain valve





# Install water piping

**WARNING** Use two wrenches when tightening water piping at boiler, using one of the wrenches to prevent the boiler interior piping from turning. Failure to support the boiler piping connections to prevent them from turning could cause damage to boiler components.

## General piping information

### Additional controls, when required

**NOTICE** The Sola module uses temperature sensors to provide both high limit protection and modulating temperature control, and is UL353 Limit Controls certified to meet ASME CSD-1 and Section IV requirements. The boiler is equipped with a manual reset low water cut-off. The Sola module also provides low water protection by sensing the temperature of the heat exchanger. Some codes/jurisdictions may require additional external controls.

### Additional limit controls

1. Consult local requirements for other codes/standards to determine if additional limit devices are needed.

**WARNING** **Multi-temperature systems** — If the heating system includes circuits that require lower temperature water (radiant slab circuits, for example) as well as higher temperature circuits, it is recommended to protect low-temperature circuits with limit controls that are wired to a Sola external limit circuit (ILK terminals for manual reset or LCI terminals for automatic reset).

2. See instructions beginning on page 51 for wiring information.
  - a. The Sola control provides two sets of limit control contacts — one set will cause automatic reset (LCI) and the other will cause manual reset (ILK) of the Sola control.
  - b. The Sola control can be reset using the RESET switch on top of the boiler.

### Low water cutoff

1. A push-to-test low water cutoff is factory-installed in the boiler. The low water cutoff probe is mounted on the front of the boiler heat exchanger.
2. The low water cutoff is manual reset (pushbutton on top of boiler) and is equipped with a push-to-test switch (top of boiler).

### Pressure/temperature gauge

1. Mount the pressure/temperature gauge (shipped loose with the boiler) in the ¼-inch tapping on top of the boiler supply outlet pipe.

**NOTICE** The boiler is shipped with a ¼" NPT pressure and temperature gauge which has a pressure range up to 75 psig. This gauge meets ASME requirements up to a relief valve setting of 50 psig. For higher pressure rated relief valves, a different pressure and temperature gauge with a higher pressure range is required. When installing a gauge that requires a larger tapping than the ¼" NPT tapping in the boiler supply manifold, provide an additional tapping in the near boiler piping BEFORE any isolation valve.

### Backflow preventer

1. Use backflow check valve in cold water supply as required by local codes.

### Install relief valve

1. Install relief valve (shipped loose with the boiler) in the 1¼-inch tapping on top of the boiler supply outlet pipe.
2. Connect discharge piping to safe disposal location, following guidelines in the **WARNING** below.

### Installing relief valve

**WARNING** **DO NOT install a relief valve with a pressure higher than 100 PSIG.** This is the maximum allowable relief valve setting for the SlimFit boiler. The boiler is shipped with a 30 PSIG relief valve. See Replacement parts in the back of this manual for alternate pressure setting relief valves.

#### To avoid water damage or scalding due to relief valve operation, as per local or state codes:

Discharge line must be connected to relief valve outlet and run to a safe place of disposal. Terminate the discharge line in a manner that will prevent possibility of severe burns or property damage should the valve discharge.

Discharge line must be as short as possible and be the same size as the valve discharge connection throughout its entire length.

Discharge line must pitch downward from the valve and terminate at least 6" above the floor drain where any discharge will be clearly visible.

The discharge line shall terminate plain, not threaded, with a material serviceable for temperatures of 375 °F or greater.

Do not pipe the discharge to any place where freezing could occur.

No shutoff valve shall be installed between the relief valve and boiler, or in the discharge line. Do not plug or place any obstruction in the discharge line.

Test the operation of the valve after filling and pressurizing system by lifting the lever. Make sure the valve discharges freely. If the valve fails to operate correctly, replace it with a new relief valve.

Failure to comply with the above guidelines could result in failure of the relief valve to operate, resulting in the possibility of severe personal injury, death or substantial property damage.



# Install water piping *(continued)*

## Recommended pipe sizing

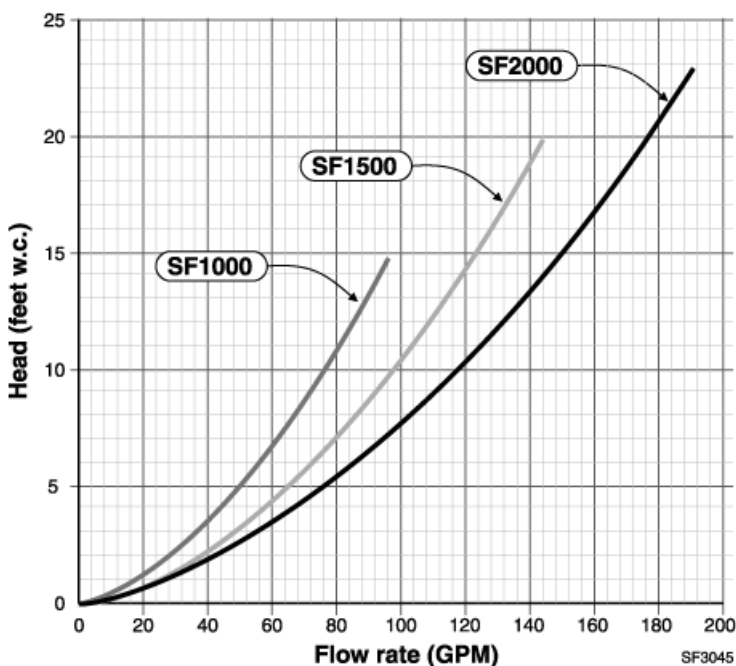
Size the piping and the pumps to provide the required temperature rise. See Figure 11 for boiler head loss curves. See Figure 13 for maximum and minimum flow rate through the boiler as well as head loss vs flow rate.

Size system piping following Figure 12 or apply recognized engineering practices to size the piping.

**⚠ WARNING** **DO NOT design the piping and components for a boiler flow rate above or below the range given in Figure 13.** Insufficient flow will cause nuisance outages due to limit operation. Excessive flow can damage the boiler heat exchanger from erosion.

For applications requiring system flow rates higher or lower than those allowed in Figure 13, use **ONLY** primary/secondary piping. Size the boiler pump for the proper flow rate.

**Figure 11** Boiler head loss vs flow rate for SlimFit boilers



**Figure 12** Recommended pipe sizing vs flow rate

Sch 40 Pipe Diameter	Maximum Flow rate GPM	Sch 40 Pipe Diameter	Maximum Flow rate GPM
2	45	6	800
3	140	8	1650
4	290	10	3000
5	500	12	4750

**NOTICE** For pipe sizes other than 3 inch, provide reducers to adapt from external piping to the boiler 3-inch supply and return flanged connections.

**⚠ WARNING** **DO NOT** design for flow rates above or below the range listed in Figure 13. The boiler and system components can be damaged by excessive or insufficient flow. Temperature rises shown below apply to water only. For glycol/water applications, the temperature rise will be different, but the flow rate must be maintained within the range listed below.

**Figure 13** Flow rate and pressure drop data for Slim-Fit boilers **AT FULL INPUT**

SF1000		
GPM	Temperature Rise (°F)	Boiler head loss (Feet w.c.)
43	44.5	4.1
50	38.3	5.1
<b>** 63</b>	<b>30.4</b>	<b>7.4</b>
70	27.4	8.7
80	24.0	10.9
90	21.3	13.3
96	20.0	14.8

\*\* Suggested design flow rate (30°F temp. rise, water only)

SF1500		
GPM	Temp. Rise °F	Boiler head loss Feet w.c.
64	44.9	4.8
75	38.3	6.3
<b>** 96</b>	<b>29.9</b>	<b>9.7</b>
105	27.4	11.3
120	24.0	14.3
135	21.3	17.7
144	20.0	19.9

\*\* Suggested design flow rate (30°F temp. rise, water only)

SF2000		
GPM	Temp. Rise °F	Boiler head loss Feet w.c.
85	44.8	6.6
100	38.1	7.8
<b>** 127</b>	<b>30.0</b>	<b>11.5</b>
140	27.2	13.5
160	23.8	16.9
180	21.2	20.6
191	20.0	22.8

\*\* Suggested design flow rate (30°F temp. rise, water only)

## Install water piping *(continued)*

### Expansion tank and make-up water

1. Ensure expansion tank size will handle boiler and system water volume and temperature. See page 126 for boiler water content.

**CAUTION** Undersized expansion tanks cause system water to be lost from relief valve and make-up water to be added through fill valve. Eventual boiler failure can result due to excessive make-up water addition.

2. Tank must be located as shown in this manual, or following recognized design methods. See tank manufacturer's instructions for details.
3. Connect the expansion tank to the air separator only if the separator is on the suction side of the pump. Always install the system fill connection at the same point as the expansion tank connection to the system.
4. Most piping drawings in this manual show diaphragm expansion tanks. See Figure 14 for piping from air separator to expansion tank and make-up water line using a closed-type expansion tank.
5. Most chilled water systems are piped using a closed-type tank, as shown in Figure 20, page 21.

### Diaphragm (or bladder) expansion tank

1. (Figure 14) Always install an automatic air vent on top of the air separator to remove residual air from the system.

**NOTICE** When using diaphragm or bladder tanks only — when the boiler is installed above the system main piping, install an automatic air vent in the top of the outgoing boiler piping to prevent air pocketing.

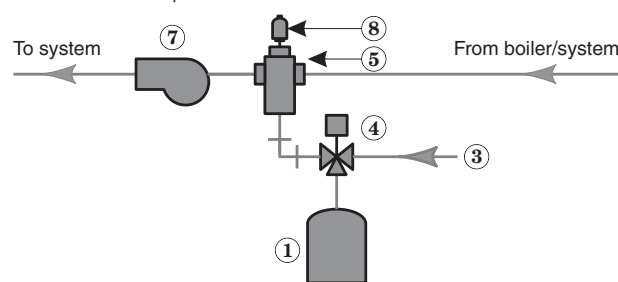
**NOTICE** The expansion tank needs to be pre-charged to the required system fill pressure before being connected to the system.

### Closed-type expansion tank

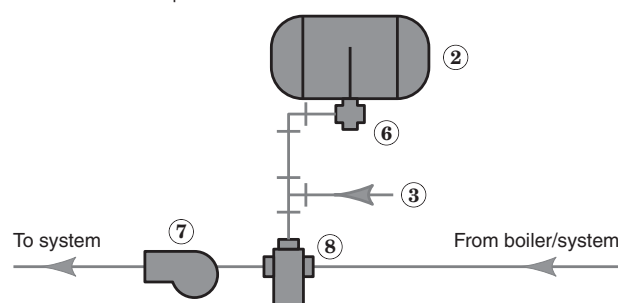
1. See Figure 15, Alternate, for piping connections when using a closed-type expansion tank.
2. Pitch any horizontal piping up towards tank 1 inch per 5 feet of piping. Connect to tank with at least ¾" piping to allow room for air to rise.

**CAUTION** DO NOT install automatic air vents on closed-type expansion tank systems. Air must remain in the system and return to the tank to provide its air cushion. An automatic air vent would cause air to leave system, resulting in water-logging the expansion tank.

**Figure 14** Expansion tank piping — diaphragm-type expansion tank



**Figure 15** Expansion tank piping — closed-type expansion tank



- 1 Diaphragm-type expansion tank
- 2 Closed-type expansion tank
- 3 Make-up water line
- 4 Fill valve, typical
- 5 Air separator
- 6 Tank fitting
- 7 System pump (when used)
- 8 Automatic air vent





# Install water piping *(continued)*

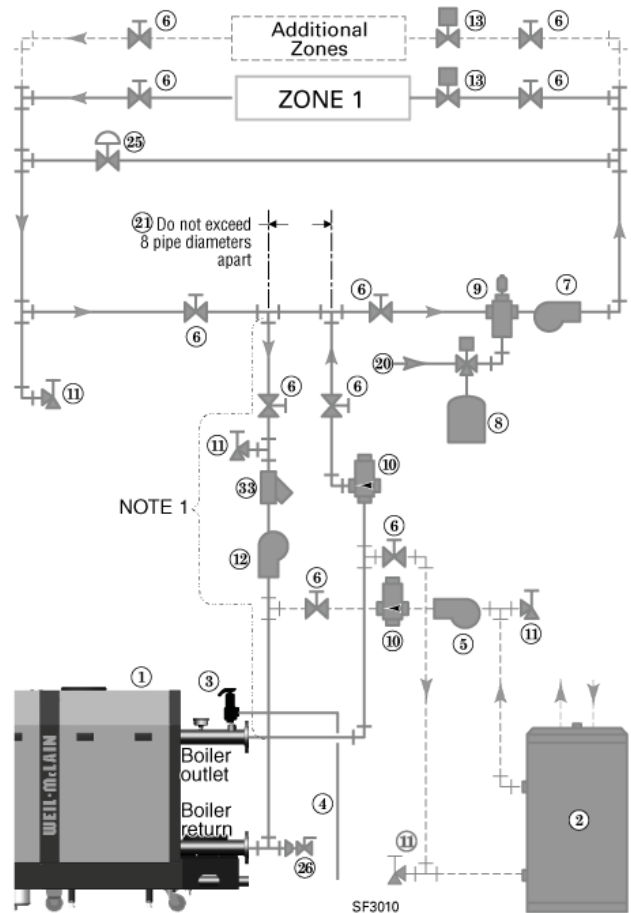
## Zoning with zone valves — primary/secondary piping

1. When using a closed-type expansion tank, connect the expansion tank and make-up water piping as shown in Figure 15, page 16.
2. Connect DHW (domestic hot water) piping to indirect storage water heater as shown. Connect from the DHW tank aquastat to the DHW terminals on the SlimFit boiler.

**⚠ WARNING** DHW tanks piped using this arrangement need to be sized for the required load, with a DHW pump selected to provide a flow rate through the boiler and tank that is within the allowable flow rate range listed in Figure 13, page 15 of this manual.

3. **DHW priority** — Set the Sola control for the desired DHW priority mode. Set the boiler pump to be OFF during DHW — it is not needed. The flow/check valve shown on the boiler outlet piping prevents gravity circulation in the boiler loop.
4. **Controlling the pumps**
  - a. The Sola can control up to three pumps. In this application, set the Sola control to operate the boiler pump, system pump and DHW pump.
  - b. Refer to Field wiring, beginning on page 51, for instructions on wiring to pumps.
  - c. The factory default settings are:
    - Pump A — Boiler pump
    - Pump B — System pump
    - Pump C — DHW pump.

**Figure 16** Zone valve zoning plus optional DHW piping



### Legend — Figure 16

- |  |   |
|--|---|
| <ul style="list-style-type: none"> <li>1 SlimFit boiler</li> <li>2 Indirect water heater (DHW), if used</li> <li>3 Boiler relief valve (see page 14 for piping details)</li> <li>4 Relief valve discharge piping (see page 14 for details)</li> <li>5 DHW pump</li> <li>6 Isolation valves</li> <li>7 System pump (see information above for wiring)</li> <li>8 Diaphragm (or bladder) type expansion tank (see page 16 for piping of closed-type expansion tank, if used)</li> <li>9 Air separator [with automatic air vent only on systems using diaphragm (or bladder) type expansion tank]</li> <li>10 Flow/check valves</li> <li>11 Purge/drain valves</li> <li>12 Boiler pump</li> </ul> | <ul style="list-style-type: none"> <li>13 Zone valves, typical</li> <li>20 Make-up water supply</li> <li>21 Primary/secondary connection (tees no more than 8 pipe diameters apart)</li> <li>25 Systems using high-head pumps require a bypass pressure regulator to prevent damage to control valves.</li> <li>26 External drain/blowdown valve, when used</li> <li>33 Strainer, recommended</li> </ul> <p>■ Items supplied with boiler<br/>■ Items supplied by others</p> |
|--|---|

**NOTE 1:** **⚠ CAUTION** Use at least 3-inch schedule 40 pipe on all boiler loop piping (connecting boiler to and from the primary/secondary connection, item 21). Pipe sizing is based on a temperature rise of 30°F, corresponding to the recommended maximum flow rate. Failure to follow these guidelines could result in system problems.

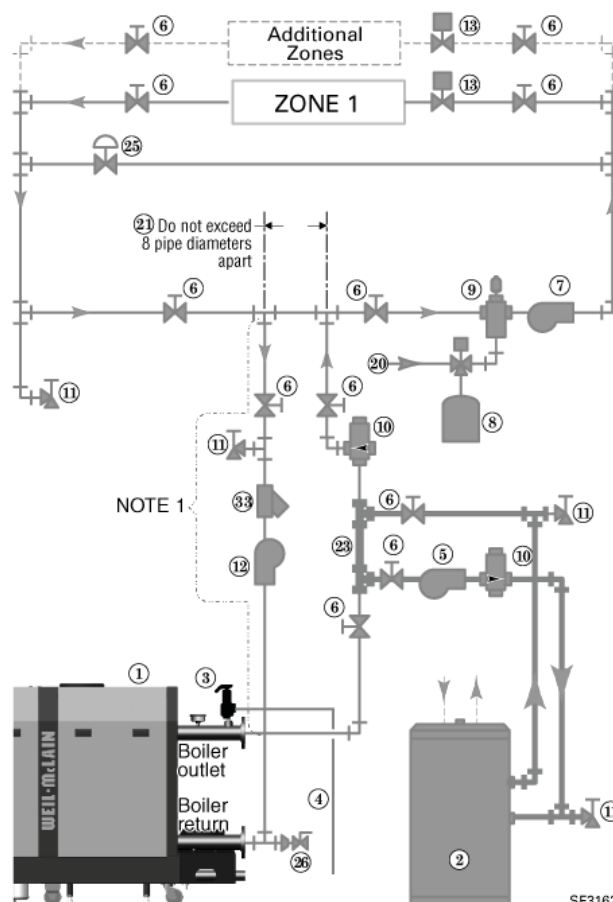
## Install water piping *(continued)*

### Zoning with zone valves — primary/secondary piping — alternate method for High-flow-rate/high-head-loss DHW circuits

- For applications requiring DHW circuit flow rates higher than allowable for the boiler, or for high pressure-drop coil-type DHW tanks, connect the piping as in Figure 17. The DHW water only flows through the secondary circuit connection piping. **NOTE:** Make sure to size the connection piping (Figure 17, item 23) for the total flow it must handle.
- When using a closed-type expansion tank, connect the expansion tank and make-up water piping as shown in Figure 15, page 16.
- Connect DHW (domestic hot water) piping to indirect storage water heater as shown. Connect from the DHW tank aquastat to the DHW terminals on the SlimFit boiler.
- DHW priority** — Set the Sola control for the desired DHW priority mode. Set the boiler pump to be OFF during DHW — it is not needed. The flow/check valve shown on the boiler outlet piping prevents gravity circulation in the boiler loop.
- Controlling the pumps**
  - The Sola can control up to three pumps. In this application, set the Sola control to operate the boiler pump, system pump and DHW pump.
  - Refer to Field wiring, beginning on page 51, for instructions on wiring to pumps.
  - The factory default settings are:
    - Pump A — Boiler pump
    - Pump B — System pump
    - Pump C — DHW pump.

**CAUTION** For systems with low-temperature radiant heating, the system pump (item 7) **MUST** be OFF during DHW heating to prevent possible overheating in the radiant system.

**Figure 17** Zone valve zoning plus optional DHW piping



#### Legend — Figure 17

- |  |   |
|--|---|
| 1 SlimFit boiler   | 20 Make-up water supply   |
| 2 Indirect water heater (DHW), if used   | 21 Primary/secondary connection (tees no more than 8 pipe diameters apart)                                |
| 3 Boiler relief valve (see page 14 for piping details)   | 23 DHW secondary connector piping — no more than 8 pipe diameters apart                                   |
| 4 Relief valve discharge piping (see page 14 for details)  | 25 Systems using high-head pumps require a bypass pressure regulator to prevent damage to control valves. |
| 5 DHW pump   | 26 External drain/blowdown valve, when used   |
| 6 Isolation valves   | 33 Strainer, recommended  |
| 7 System pump (see information above for wiring)   | ■ Items supplied with boiler  |
| 8 Diaphragm (or bladder) type expansion tank (see page 16 for piping of closed-type expansion tank, if used) | ■ Items supplied by others  |
| 9 Air separator [with automatic air vent only on systems using diaphragm (or bladder) type expansion tank]   |   |
| 10 Flow/check valves   |   |
| 11 Purge/drain valves  |   |
| 12 Boiler pump   |   |
| 13 Zone valves, typical  |   |
- NOTE 1:** **CAUTION** Use at least 3-inch schedule 40 pipe on all boiler loop piping (connecting boiler to and from the primary/secondary connection, item 21). Pipe sizing is based on a temperature rise of 30°F, corresponding to the recommended maximum flow rate. Failure to follow these guidelines could result in system problems.



## Install water piping *(continued)*

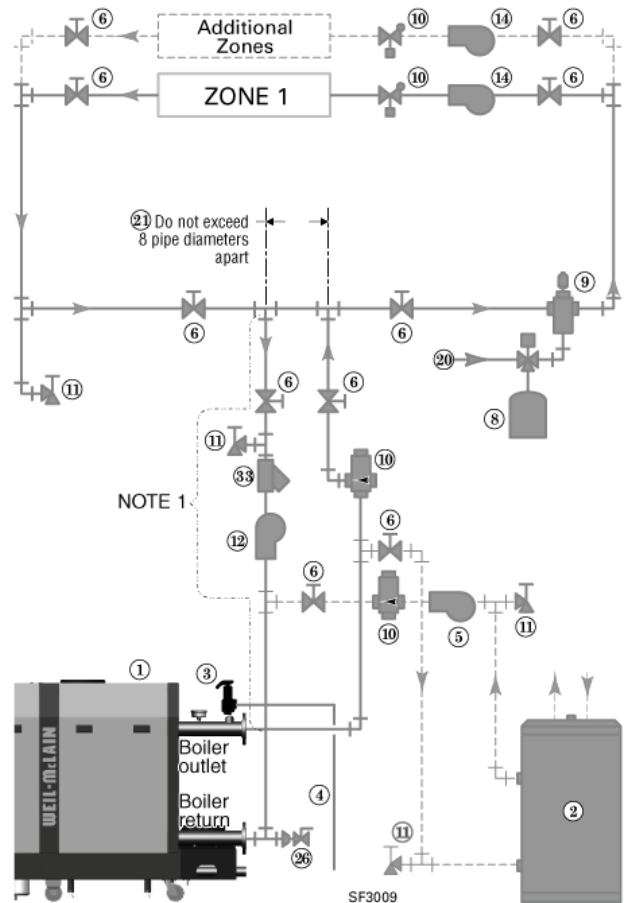
### Zoning with pumps — primary/secondary piping

1. Connect boiler to system as shown in Figure 18 when pump zoning. The boiler pump cannot be used for a zone. It must supply only the boiler loop.
2. Install a separate pump for each zone.
3. When using a closed-type expansion tank, connect the expansion tank and make-up water piping as shown in Figure 15, page 16.
4. Connect DHW (domestic hot water) piping to indirect storage water heater as shown. Connect from the DHW tank aquastat to the DHW terminals on the SlimFit boiler.

**WARNING** DHW tanks piped using this arrangement need to be sized for the required load, with a DHW pump selected to provide a flow rate through the boiler and tank that is within the allowable flow rate range listed in Figure 13, page 15 of this manual.

5. **DHW priority** — Set the Sola control for the desired DHW priority mode. Set the boiler pump to be OFF during DHW — it is not needed. The flow/check valve shown on the boiler outlet piping prevents gravity circulation in the boiler loop.
6. **Controlling the pumps**
  - a. The Sola can control up to three pumps. In this application, set the Sola control to operate the boiler pump and DHW pump.
  - b. Refer to Field wiring, beginning on page 51, for instructions on wiring to pumps.
  - c. The factory default settings are:  
Pump A — Boiler pump  
Pump C — DHW pump.
  - d. The zone pumps in Figure 18 must be controlled by pump relays activated by the zone thermostats or zone controller.

**Figure 18** Pump zoning plus optional DHW piping — primary/secondary piping



### Legend — Figure 18

- |  |  |
|--|--|
| 1 SlimFit boiler   | 14 Zone pumps, typical   |
| 2 Indirect water heater (DHW), if used   | 20 Make-up water supply  |
| 3 Boiler relief valve (see page 14 for piping details)   | 21 Primary/secondary connection (tees no more than 8 pipe diameters apart) |
| 4 Relief valve discharge piping (see page 14 for details)  | 26 External drain/blowdown valve, when used                                |
| 5 DHW pump   | 33 Strainer, recommended   |
| 6 Isolation valves   | ■ Items supplied with boiler   |
| 8 Diaphragm (or bladder) type expansion tank (see page 16 for piping of closed-type expansion tank, if used) | ■ Items supplied by others   |
| 9 Air separator [with automatic air vent only on systems using diaphragm (or bladder) type expansion tank]   |  |
| 10 Flow/check valves   |  |
| 11 Purge/drain valves  |  |
| 12 Boiler pump   |  |

**NOTE 1:** **CAUTION** Use at least 3-inch schedule 40 pipe on all boiler loop piping (connecting boiler to and from the primary/secondary connection, item 21). Pipe sizing is based on a temperature rise of 30°F, corresponding to the recommended maximum flow rate. Failure to follow these guidelines could result in system problems.



# Install water piping *(continued)*

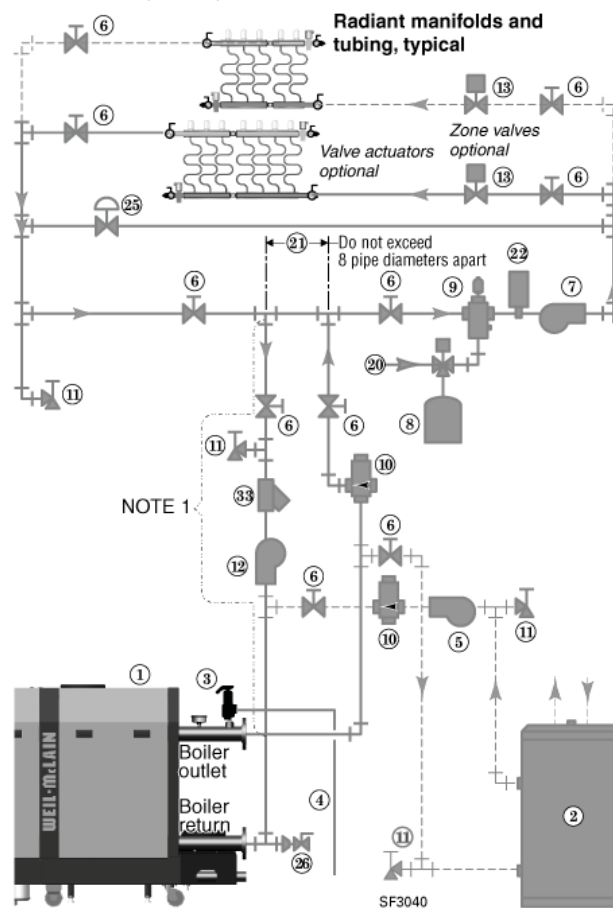
## Radiant heating applications

1. The SlimFit boiler is ideal for use in radiant heating. The SlimFit boiler's unique heat exchanger design allows it to work well even in condensing mode. So there is no need to regulate boiler return water temperature in radiant heating applications.
2. Adding the recommended high limit control (Figure 19, item 22) can help ensure supply water temperature will not exceed the maximum allowable for the radiant system. Wire this limit control in either the manual reset or automatic reset external limit circuit of the Sola.
3. When using a closed-type expansion tank, connect the expansion tank and make-up water piping as shown in Figure 15, page 16.
4. Connect DHW (domestic hot water) piping to indirect storage water heater as shown. Connect from the DHW tank aquastat to the DHW terminals on the SlimFit boiler.

**WARNING** DHW tanks piped using this arrangement need to be sized for the required load, with a DHW pump selected to provide a flow rate through the boiler and tank that is within the allowable flow rate range listed in Figure 13, page 15 of this manual.

5. **DHW priority** — Set the Sola control for the desired DHW priority mode. Set the boiler pump to be OFF during DHW — it is not needed. The flow/check valve shown on the boiler outlet piping prevents gravity circulation in the boiler loop.
6. **Controlling the pumps**
  - a. The Sola can control up to three pumps. In this application, set the Sola control to operate the boiler pump, system pump and DHW pump.
  - b. Refer to Field wiring, beginning on page 51, for instructions on wiring to pumps.
  - c. The factory default settings are:
    - Pump A — Boiler pump
    - Pump B — System pump
    - Pump C — DHW pump.

**Figure 19** Typical radiant heating system piping plus optional DHW



### Legend — Figure 19

- |  |  |
|--|--|
| <ul style="list-style-type: none"> <li>1 SlimFit boiler</li> <li>2 Indirect water heater (DHW), if used</li> <li>3 Boiler relief valve (see page 14 for piping details)</li> <li>4 Relief valve discharge piping (see page 14 for details)</li> <li>5 DHW pump</li> <li>6 Isolation valves</li> <li>7 System pump (see information above for wiring)</li> <li>8 Diaphragm (or bladder) type expansion tank (see page 16 for piping of closed-type expansion tank, if used)</li> <li>9 Air separator [with automatic air vent only on systems using diaphragm (or bladder) type expansion tank]</li> <li>10 Flow/check valves</li> <li>11 Purge/drain valves</li> <li>12 Boiler pump</li> <li>13 Zone valves, when used (zoning may also be done using manifold-mounted valve actuators)</li> </ul> | <ul style="list-style-type: none"> <li>20 Make-up water supply</li> <li>21 Primary/secondary connection (tees no more than 8 pipe diameters apart)</li> <li>22 Optional high limit temperature control, set to protect radiant tubing</li> <li>25 Systems using high-head pumps require a bypass pressure regulator to prevent damage to control valves.</li> <li>26 External drain/blowdown valve, when used</li> <li>33 Strainer, recommended</li> </ul> <p>■ Items supplied with boiler<br/>                 ■ Items supplied by others</p> |
|--|--|

**NOTE 1:** **CAUTION** Use at least 3-inch schedule 40 pipe on all boiler loop piping (connecting boiler to and from the primary/secondary connection, item 21). Pipe sizing is based on a temperature rise of 30°F, corresponding to the recommended maximum flow rate. Failure to follow these guidelines could result in system problems.



# Install water piping *(continued)*

## Chilled water systems — primary/secondary piping

1. Install boiler so that chilled medium is piped in parallel with the heating boiler. Use appropriate valves to prevent chilled medium from entering boiler. See Figure 20 for typical installation of balancing valve and check valve.
2. The space heating system may be zoned with pumps if a separate pump is supplied for the chilled water loop.

**NOTICE** If antifreeze is used in the system, consider the effects of antifreeze on pump sizing and DHW performance. Some local codes may require double-wall DHW heat exchanger design.

**WARNING** Chilled medium, if used, is piped in parallel with heating boiler as shown in Figure 20. Use appropriate valves to prevent chilled medium from entering boiler.

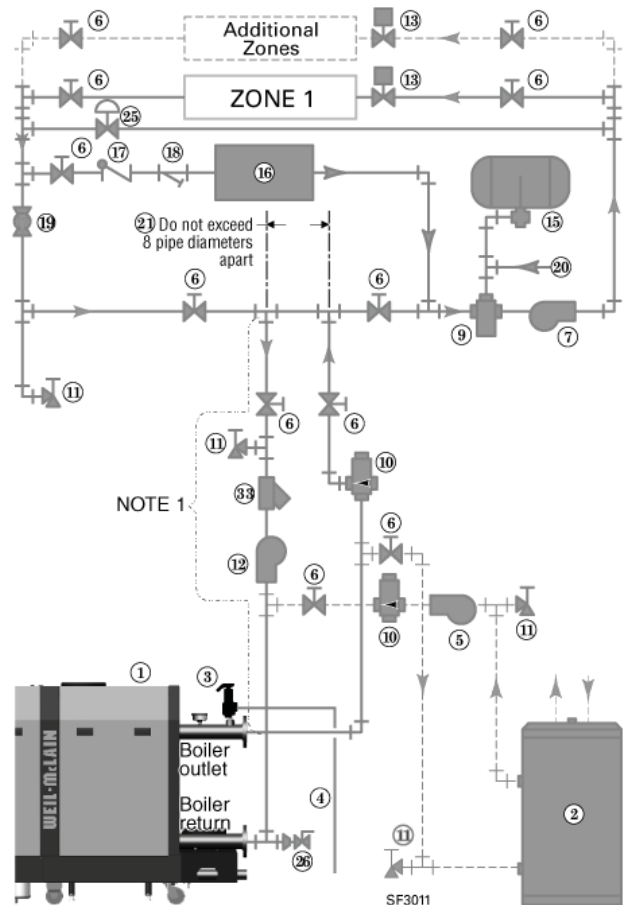
If boiler is connected to heating coils located in air handling units where they can be exposed to refrigerated air, use flow control valves or other automatic means to prevent gravity circulation during cooling cycle.

3. Connect DHW (domestic hot water) piping to indirect storage water heater as shown. Connect from the DHW tank aquastat to the DHW terminals on the SlimFit boiler.

**WARNING** DHW tanks piped using this arrangement need to be sized for the required load, with a DHW pump selected to provide a flow rate through the boiler and tank that is within the allowable flow rate range listed in Figure 13, page 15 of this manual.

4. **DHW priority** — Set the Sola control for the desired DHW priority mode. Set the boiler pump to be OFF during DHW — it is not needed. The flow/check valve shown on the boiler outlet piping prevents gravity circulation in the boiler loop.
5. **Controlling the pumps**
  - a. The Sola can control up to three pumps. In this application, set the Sola control to operate the boiler pump, system pump and DHW pump.
  - b. Refer to Field wiring, beginning on page 51, for instructions on wiring to pumps.
  - c. The factory default settings are:
    - Pump A — Boiler pump
    - Pump B — System pump
    - Pump C — DHW pump.

**Figure 20** Chilled water system plus optional DHW piping — primary/secondary piping



### Legend — Figure 20

1 SlimFit boiler	11 Purge/drain valves	26 External drain/blowdown valve, when used
2 Indirect water heater (DHW), if used	12 Boiler pump	33 Strainer, recommended
3 Boiler relief valve (see page 14 for piping details)	13 Zone valves, typical	■ Items supplied with boiler
4 Relief valve discharge piping (see page 14 for details)	15 Closed-type expansion tank	■ Items supplied by others
5 DHW pump	16 Water chiller	
6 Isolation valves	17 Check valve	
7 System pump (see information above for wiring)	18 Strainer	
9 Air separator [with automatic air vent only on systems using diaphragm (or bladder) type expansion tank]	19 Balancing valve	
10 Flow/check valves	20 Make-up water supply	
	21 Primary/secondary connection (tees no more than 8 pipe diameters apart)	
	25 Systems using high-head pumps require a bypass pressure regulator to prevent damage to control valves.	

**NOTE 1:** **CAUTION** Use at least 3-inch schedule 40 pipe on all boiler loop piping (connecting boiler to and from the primary/secondary connection, item 21). Pipe sizing is based on a temperature rise of 30°F, corresponding to the recommended maximum flow rate. Failure to follow these guidelines could result in system problems.



# Multiple boiler water piping

## Multiple boiler piping

1. Primary/secondary piping
  - a. Use only primary/secondary piping, as shown on the following pages.
  - b. Primary/secondary piping ensures flow only through operating boilers.
2. Provide a flow/check valve in the supply piping of each boiler as shown in piping diagrams in this manual. Install an isolation valve on the supply and return of each boiler as shown.
3. Install main system air eliminator and primary pump in supply piping as shown in piping diagrams.
4. Place expansion tank on suction side of system pump as shown.
5. Install system accessories as shown in drawings.
6. Piping recommendation drawings:
  - a. Figure 21, page 23 is a schematic piping drawing showing the locations of typical boiler piping and system piping, including limits and other devices often required by local codes.
  - b. Figure 22, page 24, Figure 23, page 25 and Figure 24, page 26 are three-dimensional piping drawings of typical multiple boiler installation.
  - c. Figure 25, page 27 shows recommended piping when an isolating heat exchanger is needed.
7. If desired, other primary/secondary piping arrangements can be used.

## Boiler loop pipe sizing

1. Use no smaller than 3-inch schedule 40 steel pipe (or 3-inch copper pipe) on all boiler loop piping.
2. Size boiler loop pumps to provide flow for a 30°F temperature rise. See Figure 13, page 15 for the corresponding flow rate and head loss through the boiler.
3. Total head loss for the boiler loop pumps must include the loss through all piping and fittings from the boiler to the system main piping.

## System pipe sizing

1. Size system piping based on required flow rates.
2. Also see Figure 12, page 15 for recommended pipe sizing.

**WARNING**

System design and sizing information in this manual are intended as suggested guidelines only.

Apply recognized engineering design practices when designing the system and selecting components.

**NOTICE**

Each boiler is equipped with an internal low water cutoff and limit control. Check local codes to see if additional controls may be needed.

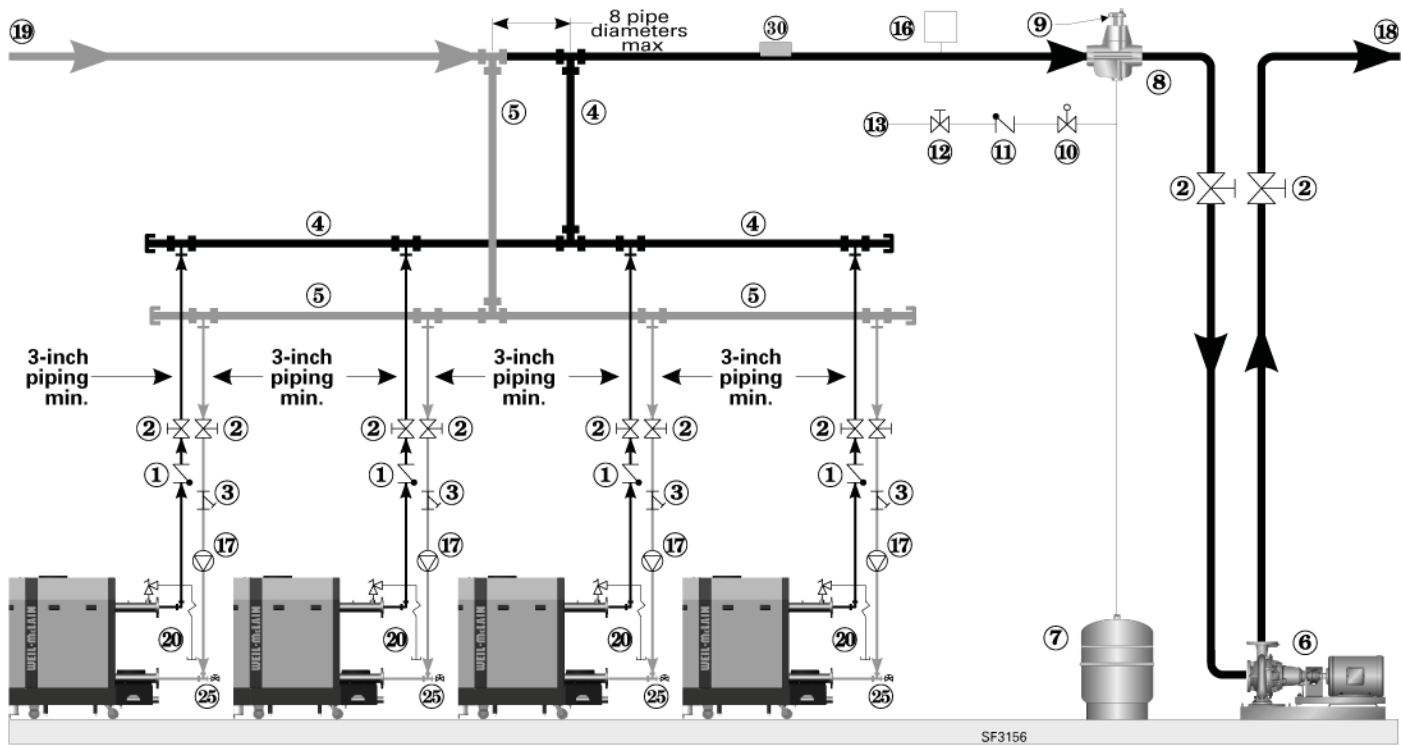
**Temperature limiting** — The Sola module uses temperature sensors to provide both high limit protection and modulating temperature control, and is UL353 Limit Controls certified to meet ASME CSD-1 and Section IV requirements.

**Low water protection** — The boiler is equipped with a manual reset low water cut-off. The Sola module also provides low water protection by sensing the temperature of the heat exchanger.



# Multiple boiler water piping *(continued)*

**Figure 21** Piping schematic — typical piping for multiple SlimFit boilers, using multiple boiler manifolds



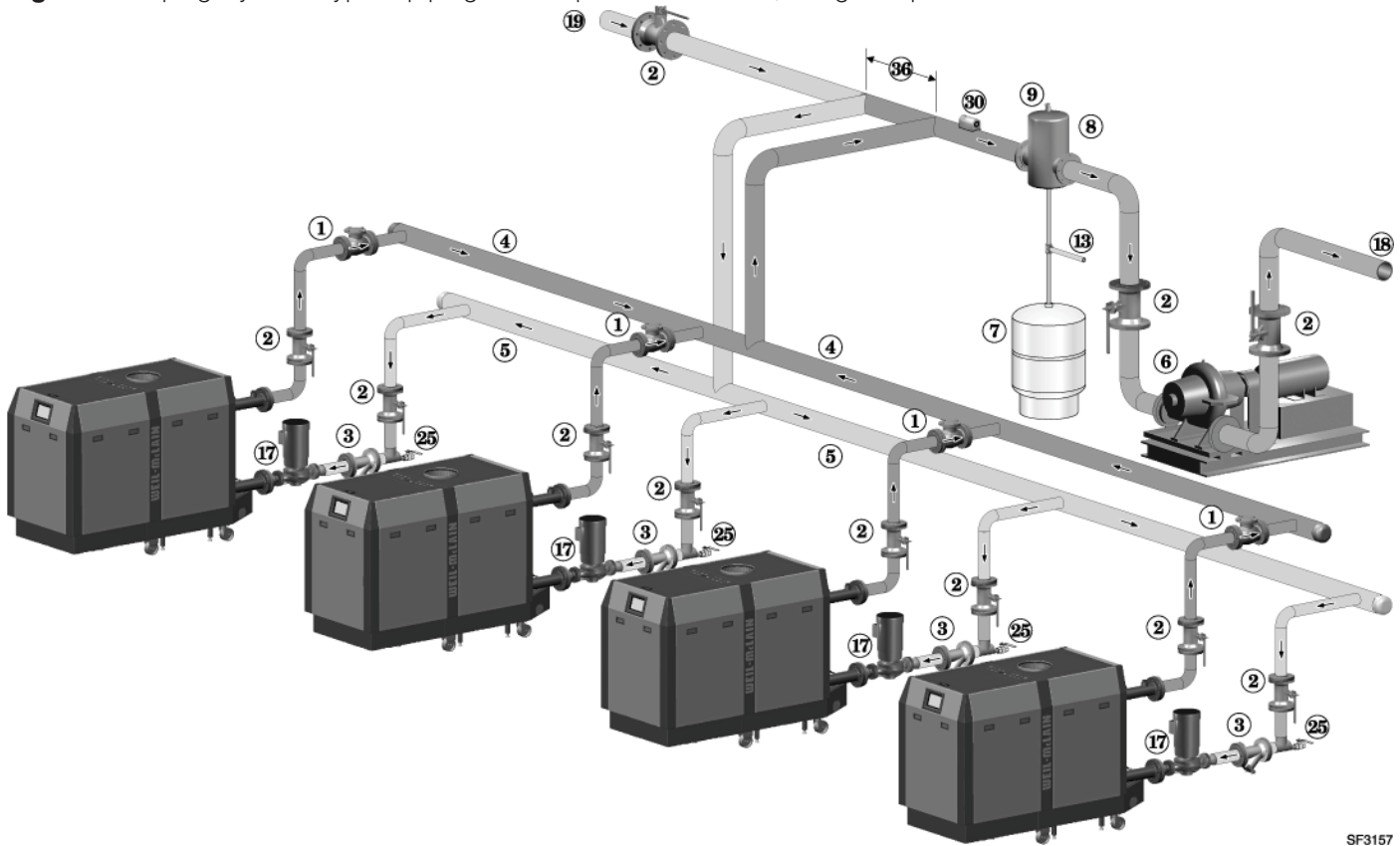
### Legend — Figure 21

- |  |  |
|--|--|
| <ul style="list-style-type: none"> <li>1 Flow/check valve (each boiler)</li> <li>2 Isolation valves (when used)</li> <li>3 Strainer (recommended one each boiler on return line)</li> <li>4 Multiple boiler manifold (supply) — layout and size per Figure 12, page 15</li> <li>5 Multiple boiler manifold (return) — layout and size per Figure 12, page 15</li> <li>6 Primary pump</li> <li>7 Expansion tank (diaphragm type)</li> <li>8 System air eliminator</li> <li>9 System automatic air vent</li> <li>10 Pressure reducing valve</li> </ul> | <ul style="list-style-type: none"> <li>11 Check valve or backflow preventer, as required by applicable codes</li> <li>12 Isolation valve</li> <li>13 Cold water supply</li> <li>16 Water flow switch (when used)</li> <li>17 Boiler pump (each boiler)</li> <li>18 System supply</li> <li>19 System return</li> <li>20 Boiler relief valve and discharge piping, installed per SlimFit Boiler Manual</li> <li>25 External drain/blowdown valve, when used, ¼" NPT or larger</li> <li>30 Strap system supply sensor to line as shown, at least 6 pipe diameters (but no more than 3 feet) from boiler connection tees.</li> </ul> |
|--|--|



# Multiple boiler water piping *(continued)*

**Figure 22** Piping layout — typical piping for multiple SlimFit boilers, using multiple boiler manifolds



SF3157

**NOTICE**

- Use 3” or larger piping for all connections between boilers and manifolds.
- Follow all sizing guidelines on page 15. Pumps must provide flow rates required.
- Use recognized engineering design practices throughout.

**Legend — Figure 22**

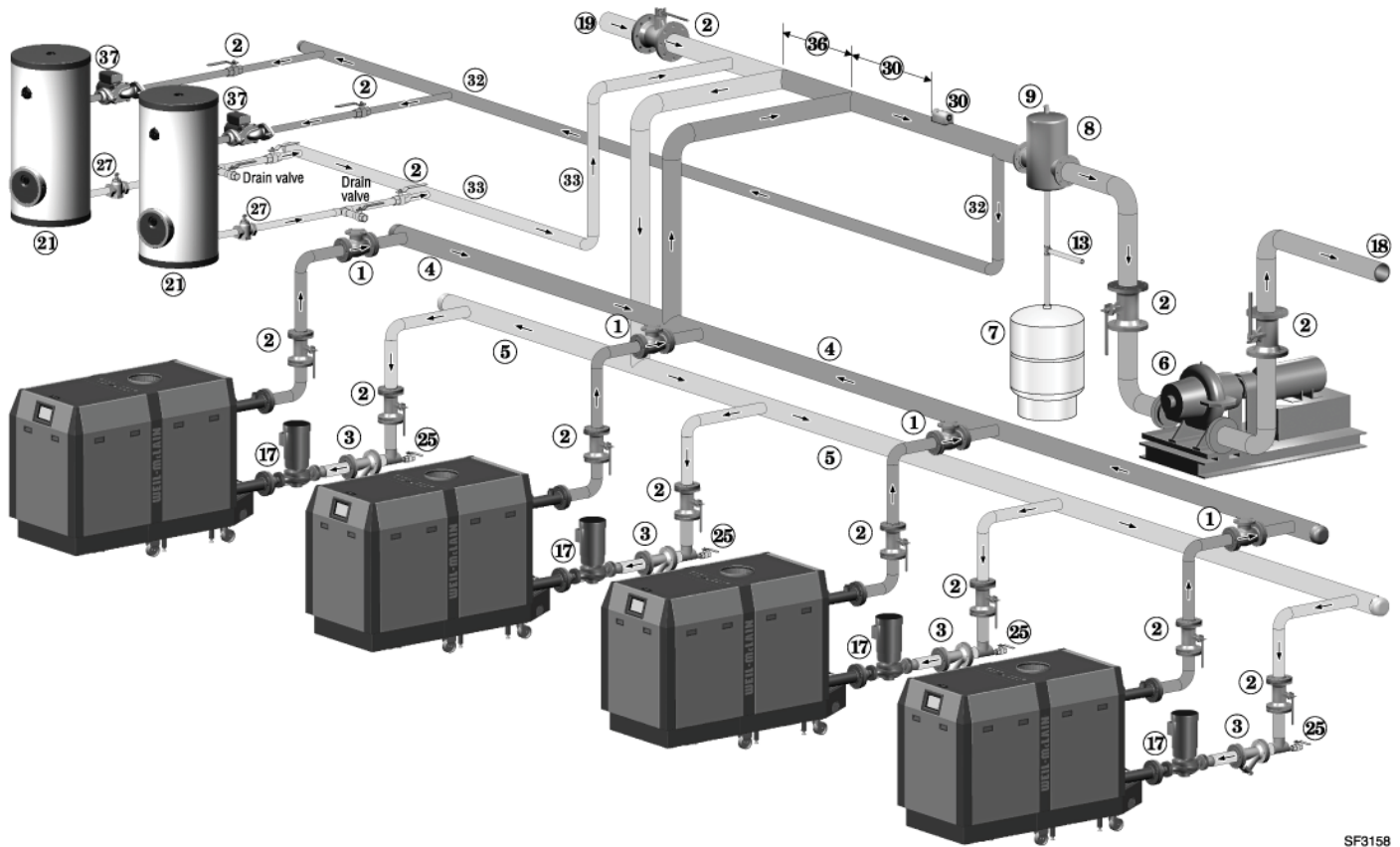
- |  |  |
|--|--|
| 1 Check valve (each boiler)  | 13 Cold water supply (requires items 10, 11 and 12 as shown in Figure 21, page 23)   |
| 2 Isolation valves   | 17 Boiler pump (each boiler)   |
| 3 Strainer (recommended on return line to each boiler)                       | 18 System supply   |
| 4 Multiple boiler manifold (supply) — layout and size per Figure 12, page 15 | 19 System return   |
| 5 Multiple boiler manifold (return) — layout and size per Figure 12, page 15 | 20 Boiler relief valve and discharge piping (not shown) — install per page 14 and all applicable codes                               |
| 6 Primary pump   | 25 External drain/blowdown valve, when used, 3/4” NPT or larger  |
| 7 Expansion tank (diaphragm type shown)                                      | 30 System supply sensor — strap to piping as shown, at least 6 pipe diameters (but no more than 3 feet) from boiler connection tees. |
| 8 System air eliminator  | 36 Secondary connection to boiler manifolds — space no greater than 8 pipe diameters apart   |
| 9 System automatic air vent  |  |





# Multiple boiler water piping *(continued)*

**Figure 23** Piping layout — typical piping for multiple SlimFit boilers, with multiple DHW storage heaters connected as a secondary circuit



SF3158

**NOTICE**

- Use 3" or larger piping for all connections between boilers and manifolds.
- Follow all sizing guidelines on page 15. Pumps must provide flow rates required.
- Use recognized engineering design practices throughout.

**Legend — Figure 23**

- |  |   |  |
|--|---|--|
| 1 Check valve (each boiler)  | 19 System return  | 30 Strap system supply sensor to the system pipe as shown. Place sensor at least 6 pipe diameters, but no more than 10 pipe diameters, from boiler supply connection to the system pipe. |
| 2 Isolation valves   | 20 Boiler relief valve and discharge piping (not shown) — install per page 14 and all applicable codes  | 32 DHW boiler-side supply manifold   |
| 3 Strainer (recommended on return line to each boiler)                             | 21 Indirect-fired storage water heaters (Weil-McLain AQUA shown). See water heater manual for DHW piping. Water heaters can be operated individually to supply separate systems or operated in tandem to supply a common system. When operating in tandem, manifold the DHW hot water outlets together. Wire the tank aquastats in series to send a DHW call to the boilers. Wire the pumps in parallel so they operate together. | 33 DHW boiler-side return manifold   |
| 4 Multiple boiler manifold (supply) — layout and size per Figure 12, page 15       |   | 36 Secondary connection to boiler manifolds — space no greater than 8 pipe diameters apart   |
| 5 Multiple boiler manifold (return) — layout and size per Figure 12, page 15       |   | 37 DHW pump  |
| 6 Primary pump   |   |  |
| 7 Expansion tank (diaphragm type shown)  |   |  |
| 8 System air eliminator  |   |  |
| 9 System automatic air vent  |   |  |
| 13 Cold water supply (requires items 10, 11 and 12 as shown in Figure 21, page 23) | 25 External drain/blowdown valve, when used, 3/4" NPT or larger   |  |
| 17 Boiler pump (each boiler)   | 27 Flow/check valve in DHW piping   |  |
| 18 System supply   |   |  |

**NOTICE**

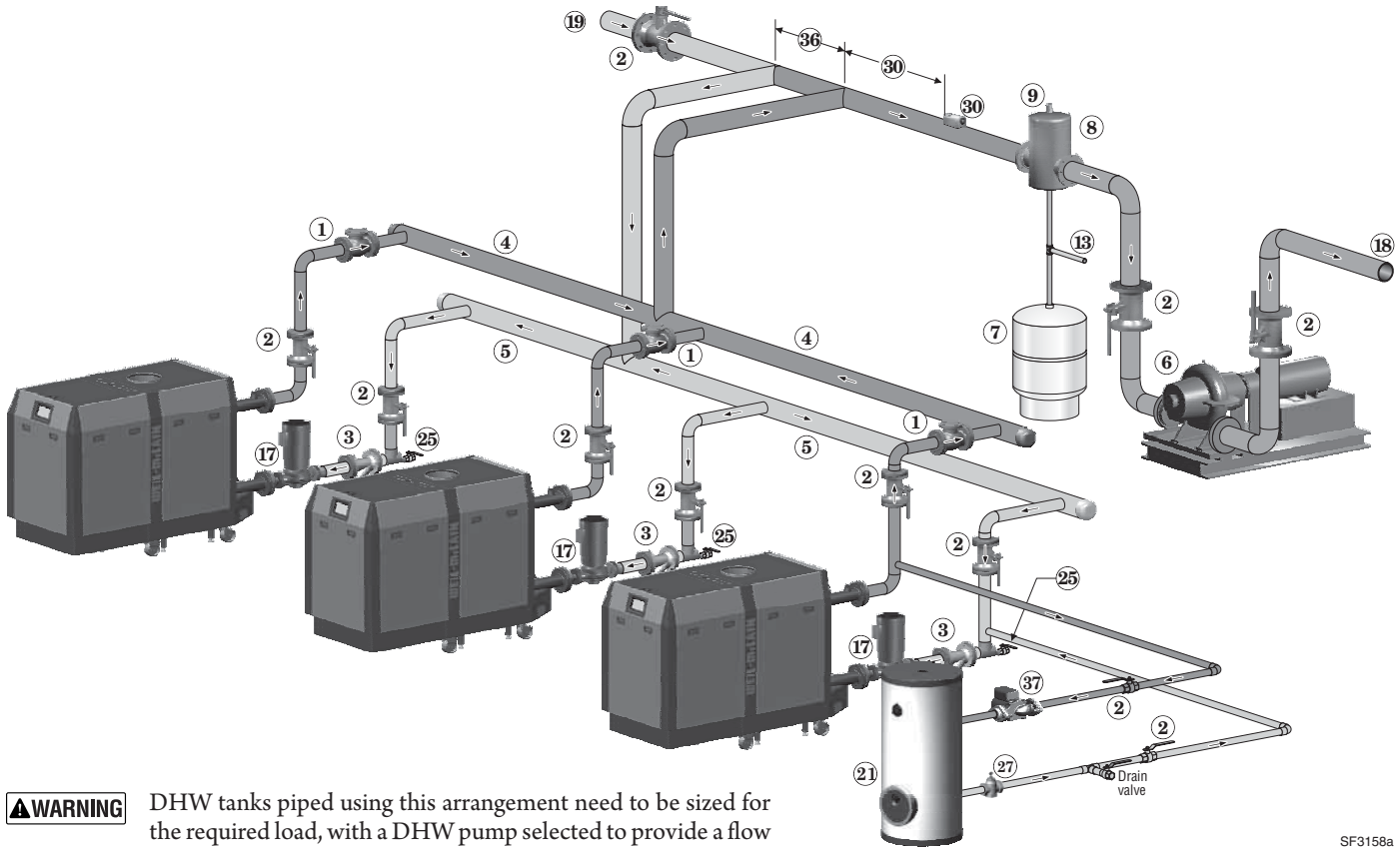
Set the Sola control so the boiler pumps, item 17, operate on any call for heat, whether heating system or DHW.

Offset the DHW boiler-side supply and return manifolds as shown so the total run of pipe and fittings to each of the water heaters is approximately equal.



# Multiple boiler water piping *(continued)*

**Figure 24** Piping layout — typical piping for multiple SlimFit boilers, with DHW storage heater (or heaters) direct-piped to one of the boilers



SF3158a

**WARNING** DHW tanks piped using this arrangement need to be sized for the required load, with a DHW pump selected to provide a flow rate through the boiler and tank that is within the allowable flow rate range listed in Figure 13, page 15 of this manual.

**NOTICE**

- Use 3” or larger piping for all connections between boilers and manifolds.
- Follow all sizing guidelines on page 15. Pumps must provide flow rates required.
- Use recognized engineering design practices throughout.

**Legend — Figure 24**

- |  |   |  |
|--|---|--|
| 1 Check valve (each boiler)  | 13 Cold water supply (requires items 10, 11 and 12 as shown in Figure 21, page 23)                        | 30 Strap system supply sensor to the system pipe as shown. Place sensor at least 6 pipe diameters, but no more than 10 pipe diameters, from boiler supply connection to the system pipe. |
| 2 Isolation valves   | 17 Boiler pump (each boiler)  | 36 Secondary connection to boiler manifolds — space no greater than 8 pipe diameters apart   |
| 3 Strainer (recommended on return line to each boiler)                       | 18 System supply  | 37 DHW pump  |
| 4 Multiple boiler manifold (supply) — layout and size per Figure 12, page 15 | 19 System return  |  |
| 5 Multiple boiler manifold (return) — layout and size per Figure 12, page 15 | 20 Boiler relief valve and discharge piping (not shown) — install per page 14 and all applicable codes    |  |
| 6 Primary pump   | 21 Indirect-fired storage water heaters (Weil-McLain AQUA shown). See water heater manual for DHW piping. |  |
| 7 Expansion tank (diaphragm type shown)                                      | 25 External drain/blowdown valve, when used, 3/4” NPT or larger   |  |
| 8 System air eliminator  | 27 Flow/check valve in DHW piping   |  |
| 9 System automatic air vent  |   |  |

**NOTICE**

Set the Sola control so the boiler pumps, item 17, operate on any call for heat, whether heating system or DHW.

Offset the DHW boiler-side supply and return manifolds as shown so the total run of pipe and fittings to each of the water heaters is approximately equal.

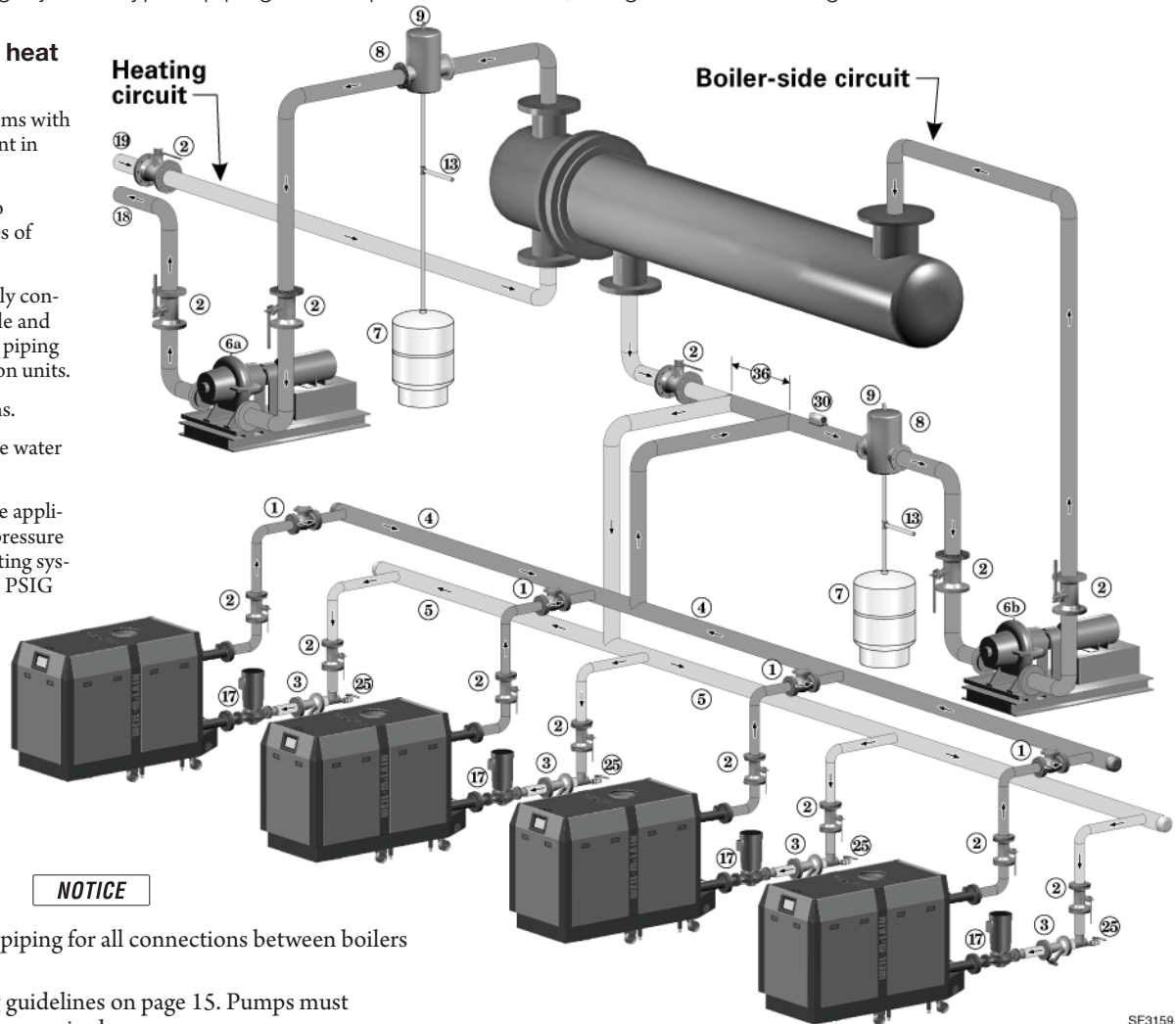


# Multiple boiler water piping *(continued)*

**Figure 25** Piping layout — typical piping for multiple SlimFit boilers, using isolation exchanger

**Use an isolation heat exchanger for:**

- Large volume systems with high mineral content in water.
- Systems exposed to untreated quantities of makeup water.
- Old systems severely contaminated with scale and rust buildup inside piping and heat distribution units.
- Process applications.
- Commercial service water applications.
- High water pressure applications, requiring pressure relief setting in heating system more than 100 PSIG (tall buildings).



**NOTICE**

- Use 3" or larger piping for all connections between boilers and manifolds.
- Follow all sizing guidelines on page 15. Pumps must provide flow rates required.
- Use recognized engineering design practices throughout.

SF3159

**Legend — Figure 23**

- |  |  |
|--|--|
| 1 Check valve (each boiler)  | 13 Cold water supply (requires items 10, 11 and 12 as shown in Figure 21, page 23)   |
| 2 Isolation valves   | 17 Boiler pump (each boiler)   |
| 3 Strainer (recommended on return line to each boiler)                       | 18 System supply   |
| 4 Multiple boiler manifold (supply) — layout and size per Figure 12, page 15 | 19 System return   |
| 5 Multiple boiler manifold (return) — layout and size per Figure 12, page 15 | 20 Boiler relief valve and discharge piping (not shown) — install per page 14 and all applicable codes   |
| 6a Heating system pump (exchanger tube-side)                                 | 25 External drain/blowdown valve, when used, ¾" NPT or larger  |
| 6b Heat exchanger shell-side pump  | 30 Strap system supply sensor to the system pipe as shown. Place sensor at least 6 pipe diameters, but no more than 10 pipe diameters, from boiler supply connection to the system pipe. |
| 7 Expansion tanks (diaphragm type)   | 36 Secondary connection to boiler manifolds — space no greater than 8 pipe diameters apart   |
| 8 System air eliminator  |  |
| 9 System automatic air vent  |  |

**NOTICE**

1. Contact heat exchanger manufacturer for heat exchanger shell-side and tube-side piping and pump requirements. Tube-side flow and temperatures must meet heating system requirements.
2. Contact heat exchanger manufacturer for sizing heat exchanger.
3. Heat exchanger shell-side circuit requires its own expansion tank as shown.
4. Heating system circuit requires its own expansion tank, as shown, plus its own relief valve set to protect heating system and heat exchanger piping and components.



# Venting/combustion air — general

**NOTICE**

There are two venting methods available. Follow the instructions on the following pages for the method used.

**Method 1: Direct exhaust**

- Combustion air taken from inside (no air piping connected to air intake)
- Sidewall or vertical termination

**Method 2: Direct vent**

- Combustion air piped to boiler from outside
- Sidewall or vertical termination

**⚠ DANGER**

**SlimFit Boilers must be vented and supplied with combustion and ventilation air using piping and methods described in this manual.**

**DO NOT COMMON VENT**

**Every boiler must have its own vent. DO NOT** common vent with any other appliance. See page 32 for checking appliances remaining on a common vent.

**INSPECT VENT/AIR COMPONENTS**

Inspect finished vent and air piping thoroughly to ensure all are airtight and comply with the instructions provided and with all requirements of applicable codes. Verify all air openings are correctly sized, unobstructed, and free of airborne contaminants.

Failure to provide a properly-installed vent and air system will cause severe personal injury or death.

**⚠ WARNING****DO NOT INSULATE NONMETALLIC VENT PIPE**

Do not cover nonmetallic vent pipe with thermal insulation.

**Code compliance****⚠ WARNING**

Venting/combustion air piping - Installations must provide provisions for combustion and ventilation air in accordance with the section "Air for Combustion and Ventilation," of the National Fuel Gas Code, ANSI Z223.1/NFPA 54, or Sections 8.2, 8.3, or 8.4 of Natural Gas and Propane Installation Code, CAN/CSA B149.1, or applicable provisions of the local building codes.

**Vent and air piping materials****⚠ WARNING**

Use only the materials listed in this manual (Figure 28, page 31) for vent and air pipe and fittings.

**A masonry chimney can ONLY be used as a chase for vent and air piping****⚠ WARNING**

**If used, a masonry chimney can ONLY be used as a PIPE CHASE for vent and air pipes** — The vent and air piping must be installed as instructed in this manual and all joints must be sealed. The chimney must be used only as a chase for the SlimFit boiler vent/air piping. NO OTHER appliance or fireplace can be connected to the chimney. The chimney must be straight, with no offsets, and the vent and air piping materials must comply with this instruction manual.

The chimney must be fitted with a sealed access opening, through which the interior of the chimney can be inspected.

The chimney and liner must be inspected at least once annually to verify condition.

Failure to comply could result in severe personal injury, death or substantial property damage.

**Air openings for direct exhaust**

1. Combustion air must be supplied through openings into the boiler room, following the instructions in this manual, and compliant with all applicable codes. Combustion air must not be exposed to any of the contaminants listed in Figure 26, page 29, and ensure the air and boiler room will not contain contaminated air.
2. Where the SlimFit boiler shares a space with other appliances, the combustion air openings must be sized to handle the combined requirements of all appliances in the space.

**Combustion air piping for direct vent**

1. Combustion air must be piped from outside to the boiler, following the instructions in this manual, and compliant with all applicable codes. Read the warning in Figure 26, page 29, and ensure the air intake will not be likely to draw in contaminated air.
2. Combustion air can be piped individually for each boiler, or it can be manifolded as shown in Figure 36, page 40. Combustion/ventilation openings may also be required in boiler room walls, per instructions in this manual and applicable codes.



# Venting/combustion air — general *(continued)*

## Combustion air contamination

1. **Direct exhaust** (combustion air from boiler room):
  - a. Provide combustion air openings to boiler room as described in this manual.
  - b. Ensure the boiler room and combustion air source areas are free of contaminants.
2. **Direct vent** (combustion air piped from outside):
  - a. Install air inlet piping for the SlimFit boiler as described in this manual.
  - b. Do not terminate air piping in locations that can allow contamination of combustion air.
3. See Figure 26 for products and areas which may cause contaminated combustion air.

**Figure 26** Corrosive contaminants and sources

Products to avoid	Areas likely to have contaminants
Spray cans containing chloro/fluorocarbons	Dry cleaning/laundry areas and establishments
Permanent wave solutions	Swimming pools
Chlorinated waxes/cleaners	Metal fabrication plants
Chlorine-based swimming pool chemicals	Beauty shops
Calcium chloride used for thawing	Refrigeration repair shops
Sodium chloride used for water softening	Photo processing plants
Refrigerant leaks	Auto body shops
Paint or varnish removers	Plastic manufacturing plants
Hydrochloric acid/muriatic acid	Furniture refinishing areas and establishments
Cements and glues	New building construction
Antistatic fabric softeners used in clothes dryers	Remodeling areas
Chlorine-type bleaches, detergents, and cleaning solvents found in household laundry rooms	Garages with workshops
Adhesives used to fasten building products and other similar products	
Excessive dust and dirt	

# Venting/combustion air — options

**Boiler vent and air connections:**  
 Provide a vent pipe mfr's **Slim-Fit VENT/AIR ADAPTER** at boiler vent connection and air connection (if used). See Figure 108, page 115 for part/kit numbers.  
 Provide pipe manufacturer's reducer(s) as needed to meet vent/air pipe size used.

<p><b>⚠ WARNING</b> <b>BIRD SCREENS —</b>                  Provide a vent manufacturer's <b>BIRD SCREEN</b> at each termination. Bird screens must be purchased from the vent/air piping supplier.</p>	<p><b>NOTICE</b> <b>USE SWEEP ELBOWS FOR ALL VENT AND AIR PIPING WHEN POSSIBLE —</b> Short-radius elbows cause higher pressure loss, resulting in less allowable vent/air piping length. See Figure 27, page 30 for maximum lengths and reductions required for fittings.</p>
--	---

<p><b>⚠ WARNING</b> <b>BOILER VENT/AIR CONNECTION GASKETS</b>                  Verify that the gasket is installed correctly, as shown in the images at right. The barbed band of the gasket must point DOWN.</p> <p><b>BOILER VENT CONNECTION CLAMP</b>                  DO NOT over-tighten the vent connection-to-vent adapter clamp. Tighten securely while checking to make sure that the clamping band does not deform or dig into the plastic vent connector.</p>	
--	--



# Venting/combustion air — options

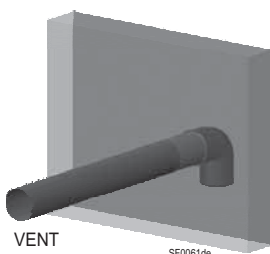
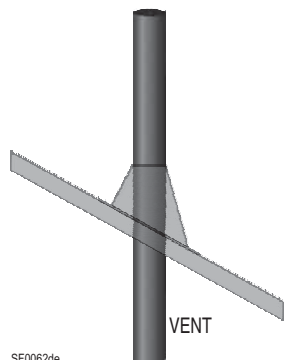
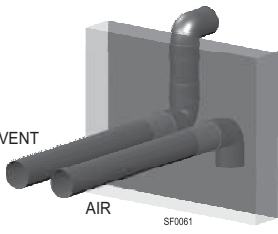
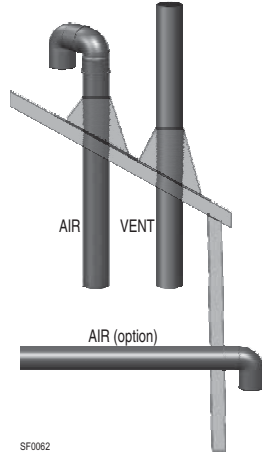
**Figure 27** SlimFit boiler venting and air piping — OPTIONS and PIPING LIMITS — The table below lists the acceptable vent/air pipe terminations described in this manual.

**USE ONLY the pipe materials listed in Figure 28, page 31 | See Figure 108, page 115 for part/kit numbers**

**Boiler vent and air connections:**

Provide a vent pipe mfr's **SlimFit VENT/AIR ADAPTER** at boiler vent connection and air connection (if used). See Figure 108, page 115 for part/kit numbers

Provide vent pipe manufacturer's reducer(s) as needed to meet vent/air pipe size used.

SlimFit Model	Pipe Size	SIDEWALL Direct Exhaust	VERTICAL Direct Exhaust	SIDEWALL Direct Vent (vent and air out sidewall)	VERTICAL Direct Vent (vertical or sidewall air)
					
		See page 37	See page 39	See page 43	See page 45
		Max/Min length, feet (note 1)	Max/Min length, feet (note 1)	Max/Min length, feet (note 1)	Max/Min length, feet (note 1)
	Thickness for wall/roof vent penetration; Max: 8" Min: 0"	Thickness for wall/roof vent penetration; Max: 8" Min: 0"	Thickness for wall/roof vent penetration; Max: 8" Min: 0"	Thickness for wall/roof vent penetration; inches Max: 8" Min: 0"	
SF1000	6"	100 max / 6 min	100 max / 6 min	100 max / 6 min	100 max / 6 min
	8"	<b>DO NOT USE 8"</b>	<b>DO NOT USE 8"</b>	150 max / 6 min	150 max / 6 min
SF1500	6"	<b>DO NOT USE 6"</b>	<b>DO NOT USE 6"</b>	<b>DO NOT USE 6"</b>	<b>DO NOT USE 6"</b>
	8"	100 max / 6 min	100 max / 6 min	100 max / 6 min	100 max / 6 min
SF2000	6"	<b>DO NOT USE 6"</b>	<b>DO NOT USE 6"</b>	<b>DO NOT USE 6"</b>	<b>DO NOT USE 6"</b>
	8"	100 max / 6 min	100 max / 6 min	100 max / 6 min	100 max / 6 min

**REDUCE MAXIMUM VENT/AIR PIPE LENGTHS FOR ELBOWS**

If the TOTAL number of elbows used in the vent and air piping and terminations is **more than two elbows in the vent piping and one elbow** in the air piping, **REDUCE** the maximum lengths above by the following lengths for each additional elbow (whether 45° or 90°).

**Note 1**

**6-inch vent/air piping — Reduce maximum allowable length by 15 feet for each additional elbow used.**

**8-inch vent/air piping — Reduce maximum allowable length by 7 feet for each additional elbow used.**

**NOTE: If the pipe manufacturer's equivalent lengths for elbows is LONGER than the values listed above, use the pipe manufacturer's value for length reduction per elbow instead.**

Boilers will **derate** as vent/air pipe length increases — see Figure 120, page 126 for derate amount vs piping length.



# Venting/combustion air — options *(continued)*

**Figure 28** Vent and air piping materials — Use only the materials listed below, ensuring that all materials meet local codes (see Figure 108, page 115 for vent/air part/kit numbers)

Items	Material	Supplier / Manufacturer	United States	Canada	
<b>Vent or air pipe and fittings</b>	<b>Polypropylene</b>	Duravent / M&G – Polypro	Certified for Category IV and direct vent appliance venting	Plastic vent pipe must be certified to ULC S636 if required by local codes	
		Centrotherm Eco Systems – InnoFlue® Single-wall	Certified for Category IV and direct vent appliance venting	Plastic vent pipe must be certified to ULC S636 if required by local codes	
	<b>AL29-4C stainless steel</b>	Heat Fab, Inc. — Saf-T-Vent®	Certified for Category IV and direct vent appliance venting	Certified for Category IV and direct vent appliance venting	
		Z-Flex, Inc. — Z-Vent II	Certified for Category IV and direct vent appliance venting	Certified for Category IV and direct vent appliance venting	
		Dura-Vent — FasNSeal™	Certified for Category IV and direct vent appliance venting	Certified for Category IV and direct vent appliance venting	
		Metal-Fab, Inc. — CORR/GUARD	Certified for Category IV and direct vent appliance venting	Certified for Category IV and direct vent appliance venting	
		<b>PVC Schedule 40</b> See Note 1 for additional requirements for using PVC on the exhaust. See Note 2.		ANSI/ASTM D1785	Plastic vent pipe must be certified to ULC S636 if required by local jurisdiction. Air pipe can be any of those listed at left if acceptable by local codes.
		<b>PVC-DWV Schedule 40</b> See Note 1 for additional requirements for using PVC on the exhaust. See Note 2.		ANSI/ASTM D2665	Plastic vent pipe must be certified to ULC S636 if required by local jurisdiction. Air pipe can be any of those listed at left if acceptable by local codes.
		<b>CPVC Schedule 40</b> See Note 2.		ANSI/ASTM F441	Plastic vent pipe must be certified to ULC S636 if required by local jurisdiction. Air pipe can be any of those listed at left if acceptable by local codes.
	<b>Primer and Cement</b>	<b>PVC</b>		ANSI/ASTM D2564 (cement) ANSI/ASTM F656 (primer)	ULC S636 rated Primers and Cements
<b>CPVC</b>			ANSI/ASTM F493 (cement) Primer that is approved for CPVC	ULC S636 rated Primers and Cements	
<b>CPVC to PVC transition</b>			Use only a Primer and Cement that is suitable for joining CPVC and PVC pipe.	ULC S636 rated Primers and Cements	

**Notes:**



1. PVC can only be used on the exhaust of a boiler after 10 linear feet of CPVC pipe. All fittings within the first 10 feet must be CPVC. See Figure 29, page 32.
2. For CPVC/PVC, See page 115, Figure 108 for SlimFit adapters to connect boiler connection to CPVC/PVC pipe.



Every joint on vent and air piping must include a locking collar. Failure to supply locking collars could result in vent/air piping leakage. All PVC and CPVC joints should be permanently joined using the suitable primer and cement for the vent material.

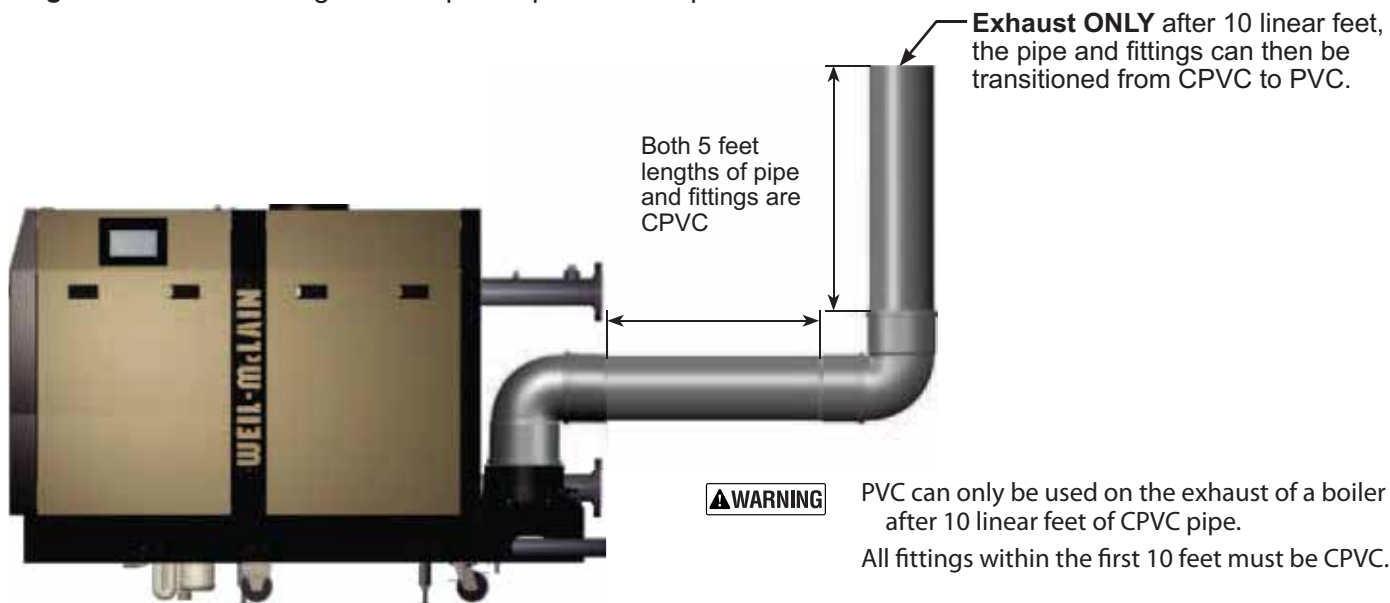


**DO NOT USE:** Cellular core PVC (ASTM F891), cellular core CPVC, or Radel® (polyphenolsulfone) pipe or any other material not listed in the table above.



**DO NOT** mix piping from different pipe manufacturers unless using adapters specifically designed for the purpose by the manufacturer.

Figure 29 PVC Venting allowed per requirements specified below.



## Appliances remaining on an existing vent system

**⚠ DANGER** Do not install the SlimFit boiler into a common vent with any other appliance. This will cause flue gas spillage or appliance malfunction, resulting in possible severe personal injury, death or substantial property damage.

**⚠ WARNING** Existing common vent systems may be too large for the appliances remaining connected after the existing boiler is removed.

**⚠ WARNING** Failure to follow all instructions can result in flue gas spillage and carbon monoxide emissions, causing severe personal injury or death.

### When removing a boiler from an existing common vent system

**The SlimFit boiler cannot be common vented with any other appliance.** When an existing boiler is replaced with a SlimFit boiler, the SlimFit boiler CANNOT use the existing common vent. The SlimFit boiler requires its own vent and air piping, as specified in this manual. This may cause a problem for the appliances that remain on the old common vent, because the vent may be too large. The following test is intended to check for proper operation of the appliances remaining on the old common vent system.

#### Vent system verification

At the time of removal of an existing boiler, the following steps shall be followed with each appliance remaining connected to the common venting system placed in operation, while the other appliances remaining connected to the common venting system are not in operation. Seal any unused openings in the common venting system.

#### Existing vent test procedure

*(The following is intended to test whether the appliances remaining on an existing vent system will operate satisfactorily.)*

1. Visually inspect the venting system for proper size and horizontal pitch and determine there is no blockage or restriction, leakage, corrosion or other deficiencies which could cause an unsafe condition.
2. Test vent system — Insofar as is practical, close all building doors and windows and all doors between the space in which the appliances remaining connected to the common venting system are located and other spaces of the building. Turn on clothes dryers and any appliance not connected to the common venting system. Turn on any exhaust fans, such as range hoods and bathroom exhausts, so they will operate at maximum speed. Do not operate a summer exhaust fan. Close fireplace dampers.
3. Place in operation the appliance being inspected. Follow the lighting instructions. Adjust thermostat so appliance will operate continuously.
4. Test for spillage at draft hood relief opening after 5 minutes of main burner operation. Use the flame of a match or candle, or smoke from a cigarette, cigar, or pipe.
5. After it has been determined that each appliance remaining connected to the common venting system properly vents when tested as outlined herein, return doors, windows, exhaust fans, fireplace dampers, and any other gas-burning appliance to their previous conditions of use.

Any improper operation of the common venting system should be corrected so the installation conforms with the National Fuel Gas Code, ANSI Z223.1/NFPA 54, and/or the Natural Gas and Propane Installation Code, CAN/CSA B149.1. When resizing any portion of the common venting system, the common venting should be resized to approach the minimum size as determined using the appropriate tables in Chapter 13 of the National Fuel Gas Code, ANSI Z223.1/NFPA 54, and/or the Natural Gas and Propane Installation Code, CAN/CSA B149.1.





## Venting/air piping — Massachusetts installations

### Venting instructions for the installations in the Commonwealth of Massachusetts

- (a) For all sidewall horizontally-vented gas-fueled equipment installed in every dwelling, building or structure used in whole or in part for residential purposes, including those owned or operated by the Commonwealth and where the side wall exhaust vent termination is less than seven (7) feet above finished grade in the area of the venting, including but not limited to decks and porches, the following requirements shall be satisfied:
- 1. INSTALLATION OF CARBON MONOXIDE DETECTORS.** At the time of installation of the side wall horizontal vented gas fueled equipment, the installing plumber or gas fitter shall observe that a hard wired carbon monoxide detector with an alarm and battery back-up is installed on the floor level where the gas equipment is to be installed. In addition, the installing plumber or gas fitter shall observe that a battery operated or hard wired carbon monoxide detector with an alarm is installed on each additional level of the dwelling, building or structure served by the side wall horizontal vented gas fueled equipment. It shall be the responsibility of the property owner to secure the services of qualified licensed professionals for the installation of hard wired carbon monoxide detectors
    - a. In the event that the side wall horizontally vented gas fueled equipment is installed in a crawl space or an attic, the hard wired carbon monoxide detector with alarm and battery back-up may be installed on the next adjacent floor level.
    - b. In the event that the requirements of this subdivision can not be met at the time of completion of installation, the owner shall have a period of thirty (30) days to comply with the above requirements; provided, however, that during said thirty (30) day period, a battery operated carbon monoxide detector with an alarm shall be installed.
  - 2. APPROVED CARBON MONOXIDE DETECTORS.** Each carbon monoxide detector as required in accordance with the above provisions shall comply with NFPA 720 and be ANSI/UL 2034 listed and IAS certified.
  - 3. SIGNAGE.** A metal or plastic identification plate shall be permanently mounted to the exterior of the building at a minimum height of eight (8) feet above grade directly in line with the exhaust vent terminal for the horizontally vented gas fueled heating appliance or equipment. The sign shall read, in print size no less than one-half (1/2) inch in size, "GAS VENT DIRECTLY BELOW. KEEP CLEAR OF ALL OBSTRUCTIONS."
  - 4. INSPECTION.** The state or local gas inspector of the side wall horizontally vented gas fueled equipment shall not approve the installation unless, upon inspection, the inspector observes carbon monoxide detectors and signage installed in accordance with the provisions of 248 CMR 5.08(2)(a) 1 through 4.
- (b) **EXEMPTIONS:** The following equipment is exempt from 248 CMR 5.08(2)(a)1 through 4:
1. The equipment listed in Chapter 10 entitled "Equipment Not Required To Be Vented" in the most current edition of NFPA 54 as adopted by the Board; and
  2. Product Approved side wall horizontally vented gas fueled equipment installed in a room or structure separate from the dwelling, building or structure used in whole or in part for residential purposes.
- (c) **MANUFACTURER REQUIREMENTS — GAS EQUIPMENT VENTING SYSTEM PROVIDED.** When the manufacturer of Product Approved side wall horizontally vented gas equipment provides a venting system design or venting system components with the equipment, the instructions provided by the manufacturer for installation of the equipment and the venting system shall include:
1. Detailed instructions for the installation of the venting system design or the venting system components; and
  2. A complete parts list for the venting system design or venting system.
- (d) **MANUFACTURER REQUIREMENTS — GAS EQUIPMENT VENTING SYSTEM NOT PROVIDED.** When the manufacturer of a Product Approved side wall horizontally vented gas fueled equipment does not provide the parts for venting the flue gases, but identifies "special venting systems", the following requirements shall be satisfied by the manufacturer:
1. The referenced "special venting system" instructions shall be included with the appliance or equipment installation instructions; and
  2. The "special venting systems" shall be Product Approved by the Board, and the instructions for that system shall include a parts list and detailed installation instructions.
- (e) A copy of all installation instructions for all Product Approved side wall horizontally vented gas fueled equipment, all venting instructions, all parts lists for venting instructions, and/or all venting design instructions shall remain with the appliance or equipment at the completion of the installation.



# DIRECT EXHAUST — Boiler room air openings

## Combustion air provision

The SlimFit Commercial boiler can use inside air if no contaminants are present in the boiler space. (If contaminants are likely to be present, install the boiler as a direct vent appliance, using the appropriate vent instructions in this manual.)

The boiler room must be fitted with combustion air openings large enough to provide air for all appliances in the room. Use the following information to size the openings. Ensure the installation complies with all applicable codes and standards.

## Sizing combustion air openings

Air openings provide for ventilation (as well as combustion air) to prevent overheating of the boiler controls and boiler space. Air is also needed for other appliances located in the same space.

Use Figure 30, page 35, selecting the appropriate installation conditions.

**WARNING** Air openings must be sized to handle all appliances and air movers (exhaust fans, etc.) using the air supply.

The sizing given in Figure 30, page 35 is based on the National Fuel Gas Code, ANSI Z223.1/NFPA54, allowing adequate air openings for gravity-vented gas appliances (Category I) in addition to that needed for the SlimFit boiler.

The SlimFit Commercial boiler is rated Category IV (pressurized vent), and has varying requirements for combustion and ventilation air, reflected by the special sizing instructions given in this manual.

The air openings recommended in Figure 30, page 35 will allow adequate ventilation and combustion air provided the boiler room is not subjected to negative pressure due to exhaust fans or other mechanical ventilation devices.

Refer to the National Fuel Gas Code for dealing with other conditions.

## Free area — louver allowance

The free area of openings means the area **after reduction for any installed louvers or grilles**. Be sure to consider this reduction when sizing the air openings.

## Special considerations

### Tight construction

ANSI Z223.1/NFPA54 defines unusually tight construction where:

1. Walls and ceilings exposed to the outside atmosphere have a continuous water vapor retarder with a rating of 1 perm or less with openings gasketed, and . . .
2. Weather-stripping has been added on openable windows and doors, and . . .
3. Caulking or sealants are applied to areas such as joints around windows and door frames, between sole plates and floors, between wall-ceiling joints, between wall panels, at penetrations for plumbing, electrical, and gas lines, and in other openings.

For buildings with such construction, provide air openings into the building from outside, sized per the appropriate case in Figure 30, page 35 if appliances are to use inside air for combustion and ventilation.

### Exhaust fans and air movers

The appliance space must never be under a negative pressure unless all appliances are installed as direct vent. Always provide air openings sized not only to the dimensions required for the firing rate of all appliances, but also to handle the air movement rate of the exhaust fans or air movers using air from the building or space.

## Combustion air damper interlock

If the air openings are fitted with motorized dampers, electrically interlock the dampers to:

- Prevent the boiler from firing if the dampers are not fully open.
- Shut the boiler down should the dampers close during boiler operation.

### External relay interlock option

Activate an external relay on call for boiler operation from any source (space heating, DHW or other). Use one of the relay contacts to start the combustion air damper. Wire the combustion air damper end switch in the boiler's **LCI** circuit (automatic reset devices).

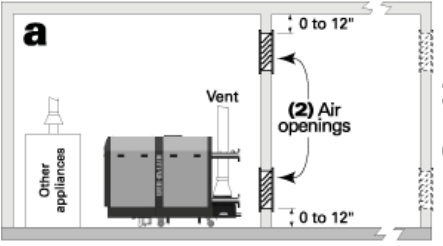
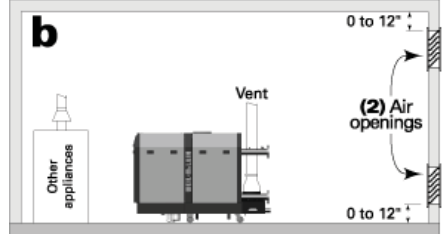
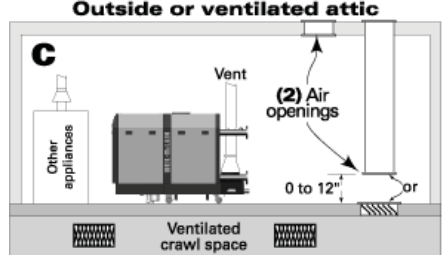
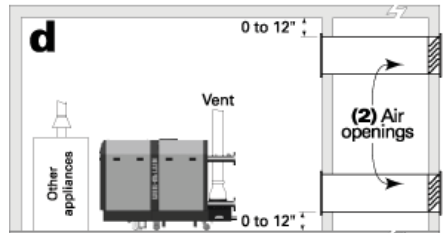
### Sola control interlock option

The Auxiliary 1 Pump function of the Sola control is factory preset to use one of the pump outputs to start a combustion air damper if the control is programmed to use Auxiliary 1. One of the control's pump outputs must be available to use this option. See page 57 for instructions. Wire the combustion air damper end switch in the boiler's **LCI** circuit (automatic reset limits).



# DIRECT EXHAUST — Boiler room air openings *(continued)*

Figure 30 MINIMUM combustion air openings for direct exhaust applications — ALL OPENING SIZES ARE FREE AREA

<p style="text-align: center;"><b>Air openings</b></p> <p>The required air opening sizes below are FREE AREA, after reduction for louver obstruction. Note the exception below for large spaces.</p>	<p style="text-align: center;"><b>SlimFit boiler WITH other appliances in room</b></p>	<p style="text-align: center;"><b>SlimFit boiler WITHOUT other appliances in room</b></p>
	<p><b>TWO</b> openings, each at least: <b>1</b> square inch per <b>1,000</b> Btuh of all appliances in the room</p>	<p><b>TWO</b> openings, each at least: <b>1</b> square inch per <b>4,000</b> Btuh of all appliances in the room</p>
	<p><b>TWO</b> openings, each at least: <b>1</b> square inch per <b>4,000</b> Btuh of all appliances in the room — OR — <b>ONE</b> opening **, each at least: <b>1</b> square inch per <b>3,000</b> Btuh of all appliances in the room</p>	<p><b>TWO</b> openings, each at least: <b>1</b> square inch per <b>4,000</b> Btuh of all appliances in the room — OR — <b>ONE</b> opening **, each at least: <b>1</b> square inch per <b>3,000</b> Btuh of all appliances in the room</p>
<p style="text-align: center;"><b>Outside or ventilated attic</b></p> 	<p><b>TWO</b> openings, each at least: <b>1</b> square inch per <b>2,000</b> Btuh of all appliances in the room — OR — <b>ONE</b> opening **, each at least: <b>1</b> square inch per <b>3,000</b> Btuh of all appliances in the room</p>	<p><b>TWO</b> openings, each at least: <b>1</b> square inch per <b>4,000</b> Btuh of all appliances in the room — OR — <b>ONE</b> opening **, each at least: <b>1</b> square inch per <b>3,000</b> Btuh of all appliances in the room</p>
	<p><b>TWO</b> openings, each at least: <b>1</b> square inch per <b>4,000</b> Btuh of all appliances in the room — OR — <b>ONE</b> opening **, each at least: <b>1</b> square inch per <b>3,000</b> Btuh of all appliances in the room</p>	<p><b>TWO</b> openings, each at least: <b>1</b> square inch per <b>4,000</b> Btuh of all appliances in the room — OR — <b>ONE</b> opening **, each at least: <b>1</b> square inch per <b>3,000</b> Btuh of all appliances in the room</p>
<p><b>** NOTICE:</b> <b>Requirements for using the SINGLE air opening option.</b></p>	<p>A single combustion air opening can be used for cases <b>b</b>, <b>c</b> or <b>d</b> above, sized as listed, provided that:</p> <ul style="list-style-type: none"> <li>• The single opening must communicate directly to the outdoors or to a space that communicates directly with outdoors (NOT to an interior space).</li> <li>• The top of the opening must be within 12 inches of the ceiling.</li> <li>• The free area of the opening must be at least equal to the sum of the areas of all equipment vent connectors in the space.</li> </ul>	
<p><b>SPECIAL EXCEPTION FOR LARGE SPACES:</b></p>	<p>NO combustion air openings are needed when the boiler (and other appliances) are installed in a space with a volume NO LESS than 50 cubic feet per 1,000 Btuh of all appliances in the space. That is, total the input of all appliances in MBH (1,000's of Btuh), then multiply this total times 50. The building MUST NOT be of tight construction.</p> <p>Example: For a total input of 1500 MBH (1,500,000 Btuh) and an 8-foot ceiling height, the minimum volume would be 50 x 1500 x 8 = 60,000 cubic feet.</p>	



# DIRECT EXHAUST — Termination location

Figure 31 DIRECT EXHAUST INSTALLATIONS — Requirements for termination location — clearances and placement

### MINIMUM CLEARANCES

### DO NOT TERMINATE:

**PLANTS**

**MECHANICAL EQUIPMENT**

Avoid possible contact with people or pets

Avoid possible damage to surfaces due to condensate freezing

Avoid spaces where wind eddies can cause recirculation

**DECK OR BALCONY**

### DO NOT TERMINATE:

**DO NOT terminate above a public walkway**

DO NOT terminate above a door or window — condensate can freeze and cause ice formations

### CONSIDER

**WINDOW**

The vent plume can block the view when the vent is located below a window.

SF0026DE

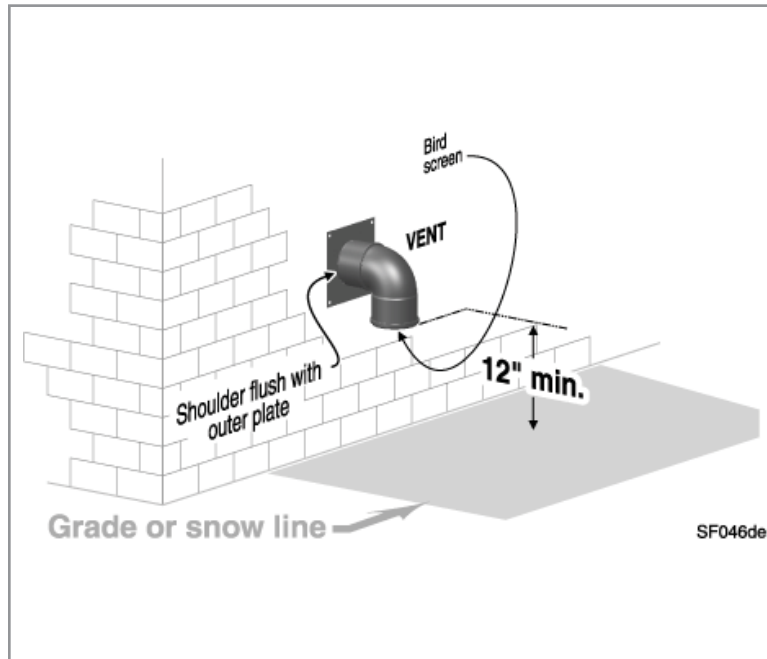
**WARNING**

**Vent Termination Locations** – the minimum distance from adjacent public walkways, adjacent buildings, openable windows and building openings shall not be less than those values specified in the National Fuel Gas Code, ANSI Z223.1/NFPA 54, and/or the Natural Gas and Propane Installation Code, CAN/CSA B149.1. Vent and air terminations must be installed at least 12 inches (0.31m) above grade and snow line. Consideration should be given to avoid possible damage caused by vent plumes and condensate when choosing a venting configuration and location. Maintain a distance of at least 4 ft. (1.22 m) horizontally from, and in no case above or below, unless a 4 ft. (1.22m) horizontal distance is maintained, from electrical meters, gas meters, regulators, and relief equipment.



## DIRECT EXHAUST — Sidewall

**Figure 32** Sidewall direct exhaust termination



**WARNING** Use only the vent materials and kits listed in Figure 28, page 31.

Read and follow all instructions in this manual. **DO NOT proceed with vent installation until you have read page 28 through page 36.**

Locate the termination such that the total vent piping from the boiler to the termination **will not exceed the maximum length given in Figure 27, page 30.**

**Comply with all vent system manufacturer's instructions.**

Provide a vent manufacturer's SlimFit Vent Adapter and reducer (if needed) at the boiler vent connection.

Every joint on **polypropylene vent piping must** include a locking collar. Failure to supply locking collars could result in vent/air piping leakage.

### Determine termination location

1. The vent termination must be installed as shown in Figure 32 and in Figure 34, page 38.
2. The termination placement must comply with clearances and limitations shown in Figure 31, page 36.
3. Locate the termination so is not likely to be damaged by foreign objects, such as stones or balls, or subject to buildup of leaves or sediment.
4. Install the boiler in a location that allows proper routing of all vent piping from the boiler vent connection to the selected sidewall location.

### Multiple vent terminations

1. When terminating multiple SlimFit boilers, terminate each vent connection as described in this manual. See Figure 33, page 38 for typical layout.
2. Place wall penetrations to obtain minimum clearances shown in Figure 32 for U. S. installations.
3. For Canadian installations, provide clearances required by CAN/CSA B149.1 Installation Code and a ULC S636 compliant vent kit.

### Install vent piping

**WARNING**

See **WARNING** about boiler vent/air outlet seals and clamp on page 29. Verify that the seal is installed correctly before inserting the vent manufacturer's SlimFit Vent Adapter.

**NOTICE**

**USE SWEEP ELBOWS FOR ALL VENT PIPING WHEN POSSIBLE** — Short-radius elbows cause higher pressure loss, resulting in less allowable vent/air piping length. See Figure 27, page 30 for maximum lengths and reductions required for fittings.

1. Install the vent manufacturer's SlimFit Vent Adapter in the boiler vent outlet. Follow all vent manufacturer instructions.
2. Install a vent manufacturer reducer if needed to adapt to the vent size being used.
3. Slope vent piping toward the boiler — slope vent piping a minimum of 1/4 inch per foot in horizontal runs or larger per vent pipe manufacturer's instructions.
4. Support piping independently of the boiler — Install pipe supports every 5 feet on both the horizontal and vertical runs. Install a hanger support within 6 inches of any upturn in the piping. Or follow vent pipe manufacturer's instructions.

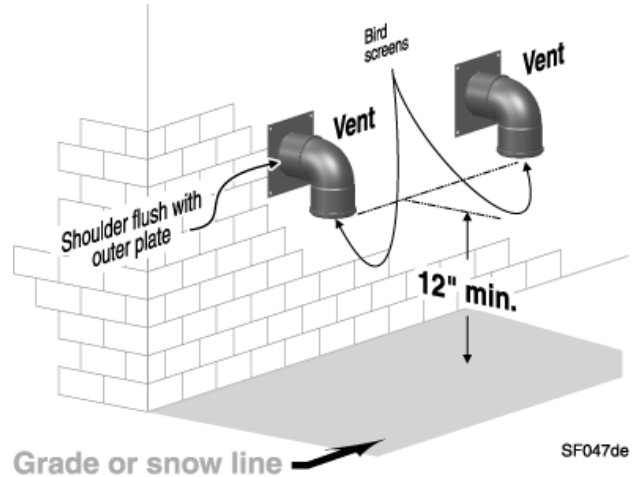
### Install vent termination elbow

1. Maintain the required dimensions of the finished termination piping as shown in Figure 32, page 37.

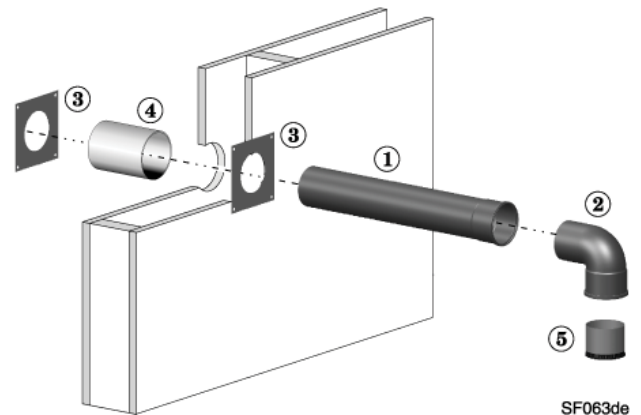
## DIRECT EXHAUST — Sidewall *(continued)*

2. Vent pipe penetration:
  - a. Cut a hole for the vent pipe.
  - b. For combustible construction, size the vent pipe hole at least  $\frac{3}{8}$ " larger than the vent pipe diameter, or larger if specified by the vent manufacturer.
  - c. For noncombustible construction, size the opening per vent manufacturer instructions.
  - d. Insert a corrosion-resistant metal thimble in the vent pipe hole as shown in Figure 34.
  - e. Follow all local codes for isolation of vent pipe when passing through floors or walls.
3. Figure 34 — Provide and install corrosion-resistant metal stop plates (item 3) as shown.
  - a. The hole size in the stop plates must be just larger than the vent pipe diameter.
  - b. Obtain stop plates ONLY from the vent pipe manufacturer.
4. Insert the last length of vent pipe from the outside. The shoulder of the vent pipe female end must rest against the outer stop plate as shown. The plate must prevent the vent from being pushed inward.
5. Insert the termination elbow into the vent pipe end.
6. Install a vent manufacturer's bird screen in the open end of the vent termination elbow.
7. Seal exterior openings thoroughly with exterior caulk.
8. For multiple boiler terminations, see Figure 33.

**Figure 33** Multiple boiler direct exhaust sidewall terminations (see Figure 32, page 37 for required clearances)



**Figure 34** Sidewall termination assembly — direct exhaust installations

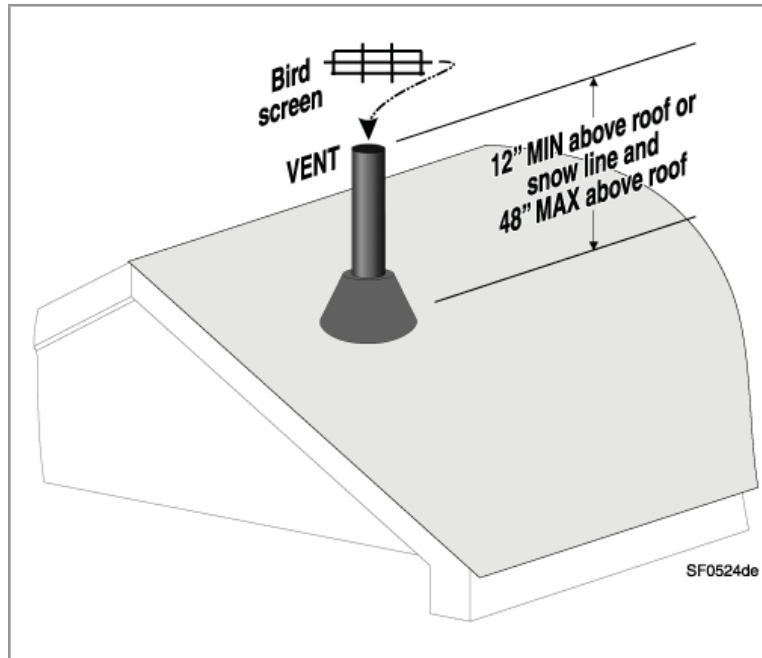


- |  |  |
|--|--|
| <ol style="list-style-type: none"> <li>1 Vent piping — insert from the outside until the female end shoulder rests against the outside stop plate</li> <li>2 Vent termination elbow — use down-turned 90-degree elbow</li> </ol> | <ol style="list-style-type: none"> <li>3 Vent manufacturer's sidewall stop plates (hole must be just larger than the vent diameter)</li> <li>4 Corrosion-resistant thimble, by installer</li> <li>5 Vent manufacturer's bird screen, by installer</li> </ol> |
|--|--|



## DIRECT EXHAUST — Vertical

Figure 35 Vertical direct exhaust termination



### ⚠ WARNING

Use only the vent materials and kits listed in Figure 28, page 31.

Read and follow all instructions in this manual. **DO NOT** proceed with vent installation until you have read page 28 through page 36.

Locate the termination such that the total vent piping from the boiler to the termination **will not exceed the maximum length given in Figure 27, page 30.**

**Comply with all vent system manufacturer's instructions.**

Provide a vent manufacturer's SlimFit Vent Adapter and reducer (if needed) at the boiler vent connection.

Every joint on **polypropylene vent piping must** include a locking collar. Failure to supply locking collars could result in vent/air piping leakage.

### Determine termination location

1. The vent termination must be installed as shown in Figure 35.
2. The termination placement must comply with clearances and limitations shown in Figure 31, page 36.
3. Locate the termination so is not likely to be damaged by foreign objects, such as stones or balls, or subject to buildup of leaves or sediment.
4. Install the boiler in a location that allows proper routing of all vent piping from the boiler vent connection to the selected sidewall location.

### Multiple vent terminations

1. When terminating multiple SlimFit boilers, terminate each vent connection as described in this manual.
2. Place wall penetrations to obtain minimum clearances shown in Figure 35 for U. S. installations.
3. For Canadian installations, provide clearances required by CAN/CSA B149.1 Installation Code and a ULC S636 compliant vent kit.

### Install vent piping

#### ⚠ WARNING

See **WARNING** about boiler vent/air outlet seals and clamp on page 29. Verify that the seal is installed correctly before inserting the vent manufacturer's SlimFit Vent Adapter.

#### NOTICE

**USE SWEEP ELBOWS FOR ALL VENT PIPING WHEN POSSIBLE** — Short-radius elbows cause higher pressure loss, resulting in less allowable vent/air piping length. See Figure 27, page 30 for maximum lengths and reductions required for fittings.

1. Install the vent manufacturer's SlimFit Vent Adapter in the boiler vent outlet. Follow all vent manufacturer instructions.
2. Install a vent manufacturer reducer if needed to adapt to the vent size being used.

3. Slope vent piping toward the boiler — slope vent piping a minimum of  $\frac{1}{4}$  inch per foot in horizontal runs or larger per vent pipe manufacturer's instructions.
4. Support piping independently of the boiler — Install pipe supports every 5 feet on both the horizontal and vertical runs. Install a hanger support within 6 inches of any upturn in the piping. Or follow vent pipe manufacturer's instructions.

### Install vent termination

1. Vent pipe penetration:
  - a. Cut a hole for the vent pipe.
  - b. For combustible construction, size the vent pipe hole at least  $\frac{3}{8}$ " larger than the vent pipe diameter, or larger if specified by the vent manufacturer.
  - c. For noncombustible construction, size the opening per vent manufacturer instructions.
  - d. Insert a corrosion-resistant metal thimble in the vent pipe hole.
  - e. Follow all local codes for isolation of vent pipe when passing through floors, ceilings and roofs.
2. Provide flashing and sealing boots sized for the vent pipe.
3. Use a coupling or open-end pipe termination, following vent manufacturer's guidelines for vertical terminations.
4. Install a vent manufacturer's bird screen in the open end of the termination.
5. Maintain the required dimensions of the finished termination piping as shown in Figure 35.

#### ⚠ WARNING

Do not exceed the maximum length of the outside vent piping shown in Figure 35. Excessive length exposed to the outside could result in freezing of condensate in the vent pipe or vent/air piping failure. Follow vent/air pipe manufacturer's instructions for proper protection and support of the piping and for installations in very cold climates.

# DIRECT VENT — Boiler room air openings

## Combustion/ventilation air provision

For direct vent installations, combustion air must be ducted directly from outside to the SlimFit boiler air intake fitting. Two options are available: sidewall or vertical direct vent. Though combustion air is ducted to the SlimFit boiler, the boiler room will still require air openings, either for ventilation or for combustion air for other appliances plus ventilation.

## Sizing air openings

Air openings provide for ventilation (as well as combustion air) to prevent overheating of the boiler controls and boiler space. Air is also needed for other appliances located in the same space.

Use Figure 37, page 41, selecting the appropriate installation conditions.

**WARNING** Air openings must be sized to handle all appliances and air movers (exhaust fans, etc.) using the air supply.

The sizing given in Figure 37, page 41 is based on the National Fuel Gas Code, ANSI Z223.1/NFPA54, allowing adequate air opening for gravity-vented gas appliances (Category I) when located in the same space as the SlimFit boiler.

When outside air is ducted as directed in this manual, the SlimFit boiler is rated as direct vent (pressurized vent), and has varying requirements for combustion and ventilation air, reflected by the special sizing instructions given in Figure 37, page 41.

The air openings recommended in Figure 37, page 41 will allow adequate ventilation and combustion air provided the boiler room is not subjected to negative pressure due to exhaust fans or other mechanical ventilation devices. Refer to the National Fuel Gas Code for dealing with other conditions.

## Louver allowance

The free area of openings means the area **after reduction for any installed louvers or grilles**. Be sure to consider this reduction when sizing the air openings.

## Special considerations

### Tight construction

ANSI Z223.1/NFPA54 defines unusually tight construction where:

1. Walls and ceilings exposed to the outside atmosphere have a continuous water vapor retarder with a rating of 1 perm or less with openings gasketed, and . . .
2. Weather-stripping has been added on openable windows and doors, and . . .
3. Caulking or sealants are applied to areas such as joints around windows and door frames, between sole plates and floors, between wall-ceiling joints, between wall panels, at penetrations for plumbing, electrical, and gas lines, and in other openings.

For buildings with such construction, provide air openings into the building from outside, sized per the appropriate case in Figure 37, page 41 if appliances are to use inside air for combustion and ventilation.

## Exhaust fans and air movers

The appliance space must never be under a negative pressure unless all appliances are installed as direct vent. Always provide air openings sized not only to the dimensions required for the firing rate of all appliances, but also to handle the air movement rate of the exhaust fans or air movers using air from the building or space.

## Motorized air dampers

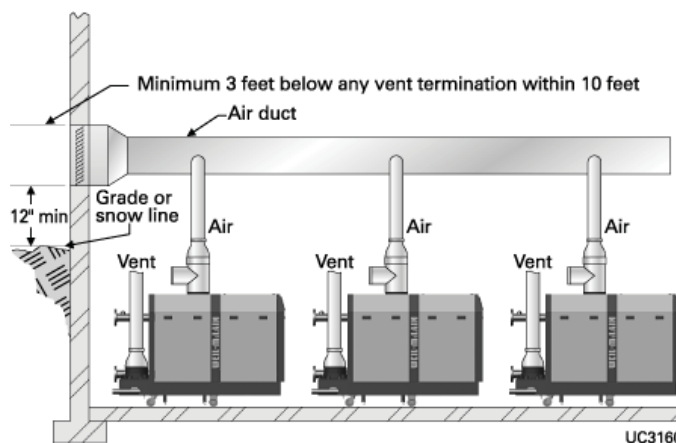
See “Combustion air damper interlock” on page 34 for recommendations on wiring motorized air dampers.

## Manifolded combustion air option

1. Multiple SlimFit boilers can use a common combustion air manifold.
  - a. Size the duct to provide at least 1 square inch per 1,000 Btuh total input of connected boilers.
  - b. Provide minimum clearance to adjacent vents and grade/snow line as shown in Figure 36.
  - c. Provide minimum free area in duct (adjusted for louver restriction) of **1 square inch per 2,000 Btuh** total boiler input, or divide the total MBH (1000's Btuh) by 2.
  - d. Example: For an MBS system with total input of 3,000,000 Btuh, or 3,000 MBH: Divide 3,000 by 2 = 1500 square inches minimum for a combined air duct.
  - e. If combustion air damper is used, wire to boilers to prevent operation except after damper has opened (see Motorized air dampers, above).

**WARNING** ONLY air piping can be combined. DO NOT use combined vent piping. Flue gas leakage and boiler component damage can occur. Failure to comply could result in severe personal injury, death or substantial property damage.

Figure 36 Manifolded combustion air option

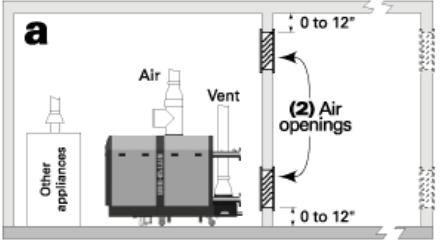
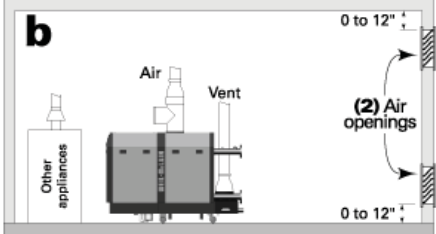
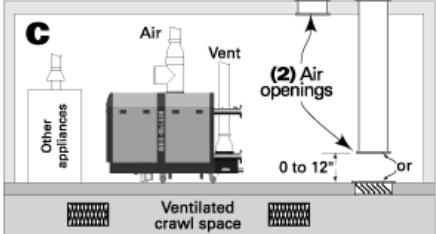
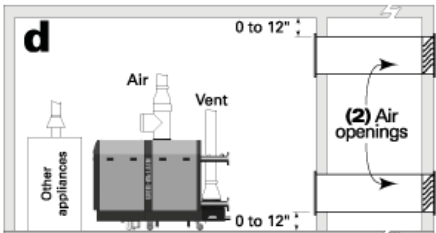






# DIRECT VENT — Boiler room air openings *(continued)*

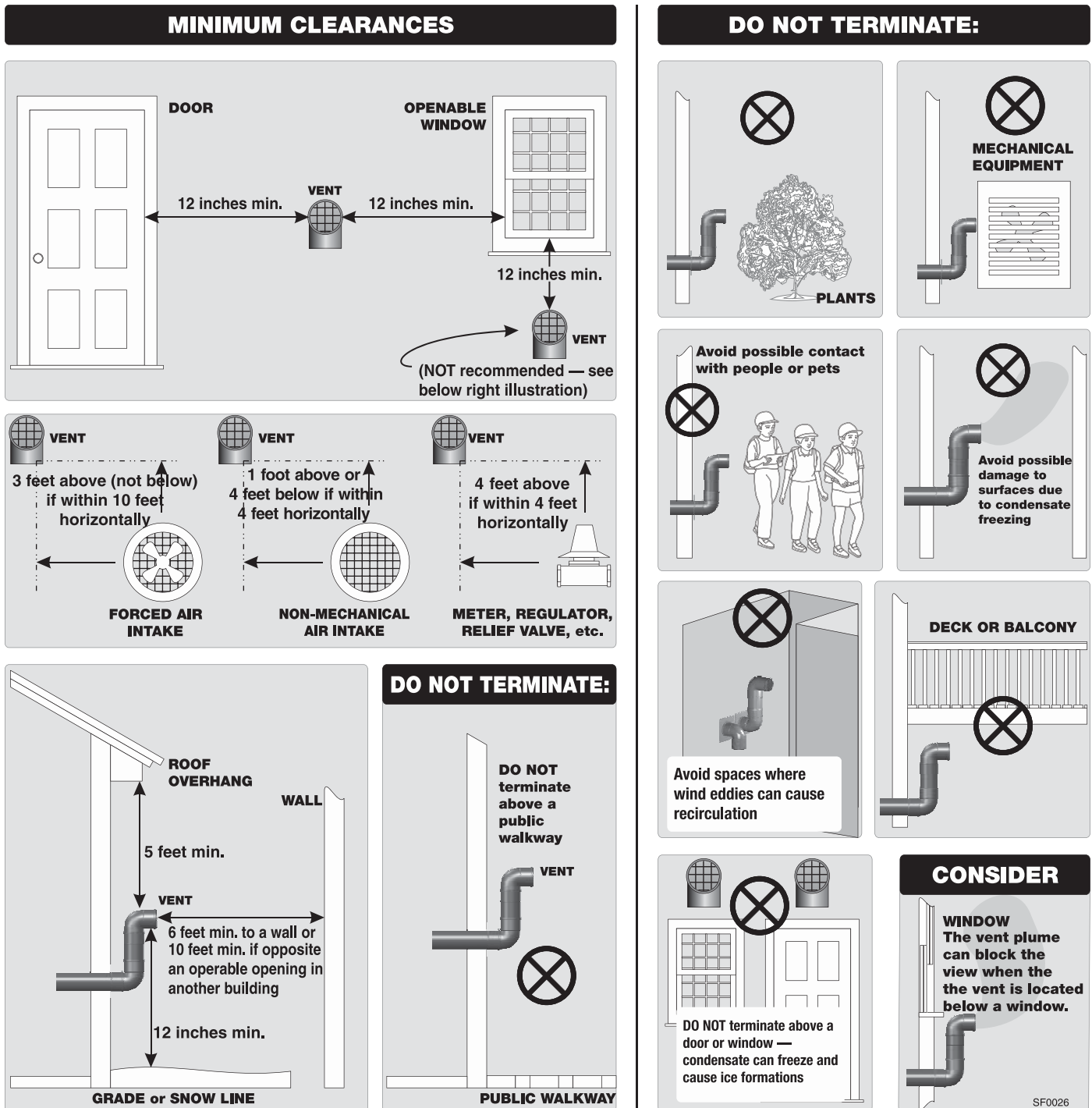
Figure 37 MINIMUM combustion air openings for direct vent applications — ALL OPENING SIZES ARE FREE AREA

<p style="text-align: center;"><b>Air openings</b></p> <p>The required air opening sizes below are FREE AREA, after reduction for louver obstruction. Note the exception below for large spaces.</p>	<p style="text-align: center;"><b>SlimFit boiler WITH other appliances in room</b></p>	<p style="text-align: center;"><b>SlimFit boiler WITHOUT other appliances in room</b></p>
	<p><b>TWO</b> openings, each at least: <b>1</b> square inch per <b>1,000</b> Btuh of all other appliances in the room</p>	<p><b>NO</b> openings are required if the boiler installation provides at least the Recommended service clearances shown on page 7.</p> <p>If the space is smaller, provide ONE opening to a larger room with at least <b>1</b> square inch per <b>3,000</b> Btuh of SlimFit boiler input.</p>
	<p><b>TWO</b> openings, each at least: <b>1</b> square inch per <b>4,000</b> Btuh of all other appliances in the room — OR — <b>ONE</b> opening **, each at least: <b>1</b> square inch per <b>3,000</b> Btuh of all other appliances in the room</p>	<p><b>NO</b> openings are required if the boiler installation provides at least the Recommended service clearances shown on page 7.</p> <p>If the space is smaller, provide ONE opening to a larger room with at least <b>1</b> square inch per <b>3,000</b> Btuh of SlimFit boiler input.</p>
	<p><b>TWO</b> openings, each at least: <b>1</b> square inch per <b>2,000</b> Btuh of all other appliances in the room — OR — <b>ONE</b> opening **, each at least: <b>1</b> square inch per <b>3,000</b> Btuh of all other appliances in the room</p>	<p><b>NO</b> openings are required if the boiler installation provides at least the Recommended service clearances shown on page 7.</p> <p>If the space is smaller, provide ONE opening to a larger room with at least <b>1</b> square inch per <b>3,000</b> Btuh of SlimFit boiler input.</p>
	<p><b>TWO</b> openings, each at least: <b>1</b> square inch per <b>4,000</b> Btuh of all other appliances in the room — OR — <b>ONE</b> opening **, each at least: <b>1</b> square inch per <b>3,000</b> Btuh of all other appliances in the room</p>	<p><b>NO</b> openings are required if the boiler installation provides at least the Recommended service clearances shown on page 7.</p> <p>If the space is smaller, provide ONE opening to a larger room with at least <b>1</b> square inch per <b>3,000</b> Btuh of SlimFit boiler input.</p>
<p><b>** NOTICE:</b> <b>Requirements for using the SINGLE air opening option.</b></p>	<p>A single combustion air opening can be used for cases <b>b</b>, <b>c</b> or <b>d</b> above, sized as listed, provided that:</p> <ul style="list-style-type: none"> <li>• The single opening must communicate directly to the outdoors or to a space that communicates directly with outdoors (NOT to an interior space).</li> <li>• The top of the opening must be within 12 inches of the ceiling.</li> <li>• The free area of the opening must be at least equal to the sum of the areas of all equipment vent connectors in the space.</li> </ul>	
<p><b>SPECIAL EXCEPTION FOR LARGE SPACES:</b></p>	<p>NO combustion air openings are needed when the boiler (and other appliances) are installed in a space with a volume NO LESS than 50 cubic feet per 1,000 Btuh of all appliances in the space. That is, total the input of all appliances in MBH (1,000's of Btuh), then multiply this total times 50. The building MUST NOT be of tight construction.</p> <p>Example: For a total input of 1500 MBH (1,500,000 Btuh) and an 8-foot ceiling height, the minimum volume would be 50 x 1500 x 8 = 60,000 cubic feet.</p>	



# DIRECT VENT — Termination location

Figure 38 DIRECT VENT INSTALLATIONS — Requirements for termination location — clearances and placement



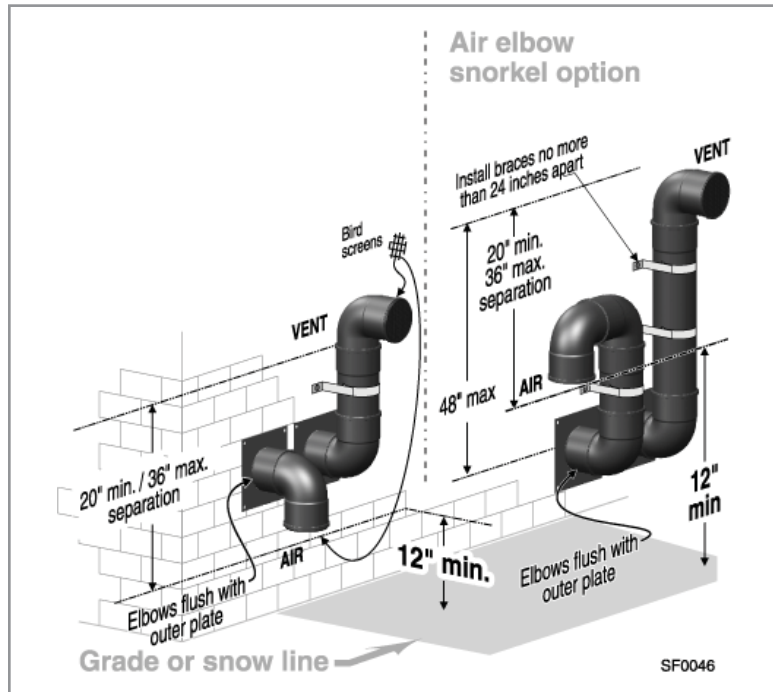
**WARNING**

**Vent Termination Locations** – the minimum distance from adjacent public walkways, adjacent buildings, openable windows and building openings shall not be less than those values specified in the National Fuel Gas Code, ANSI Z223.1/NFPA 54, and/or the Natural Gas and Propane Installation Code, CAN/CSA B149.1. Vent and air terminations must be installed at least 12 inches (0.31m) above grade and snow line. Consideration should be given to avoid possible damage caused by vent plumes and condensate when choosing a venting configuration and location. Maintain a distance of at least 4 ft. (1.22 m) horizontally from, and in no case above or below, unless a 4 ft. (1.22m) horizontal distance is maintained, from electrical meters, gas meters, regulators, and relief equipment.



## DIRECT VENT — Sidewall

Figure 39 Sidewall direct vent terminations — vent and air



### ⚠ WARNING

Use only the vent/air materials and kits listed in Figure 28, page 31.

Read and follow all instructions in this manual. **DO NOT proceed with vent/air installation until you have read page 28 through page 33 and page 40 through page 42.**

Locate the termination such that the total vent piping from the boiler to the termination **will not exceed the maximum length given in Figure 27, page 30.**

**Comply with all vent system manufacturer's instructions.**

Provide a vent manufacturer's SlimFit Vent Adapter and reducer (if needed) at the boiler vent connection.

Every joint on **polypropylene vent piping must** include a locking collar. Failure to supply locking collars could result in vent/air piping leakage.

### Determine termination location

1. The vent termination must be installed as shown in Figure 39 and in Figure 42, page 44.
2. The termination placement must comply with clearances and limitations shown in Figure 31, page 36.
3. Locate the terminations so they are not likely to be damaged by foreign objects, such as stones or balls, or subject to buildup of leaves or sediment.
4. Install the boiler in a location that allows proper routing of all vent and air piping from the boiler vent and air connections to the selected sidewall location.

### ⚠ WARNING

Do not exceed the maximum lengths of the outside vent piping shown in Figure 39. Excessive length exposed to the outside could result in freezing of condensate in the vent pipe or vent/air piping failure. Follow vent/air pipe manufacturer's instructions for proper protection and support of the piping. In extremely cold climates, install an insulated chase around the vent piping, particularly when using longer lengths. (DO not insulate nonmetallic vent pipe, if used.) The chase must allow for inspection of the vent pipe, and insulation must be protected from water.

### Multiple vent terminations

1. When terminating multiple SlimFit boilers, terminate each vent connection as described in this manual. See Figure 41, page 44 for a typical layout.
2. Place wall penetrations to obtain minimum clearances shown in Figure 39 and in Figure 41, page 44 for U. S. installations.
3. For Canadian installations, provide clearances required by CAN/CSA B149.1 Installation Code and a ULC S636 compliant vent kit.

### Install vent piping

### ⚠ WARNING

See **WARNING** about boiler vent/air outlet seals and vent clamp on page 29. Verify that the seal is installed correctly before inserting the vent manufacturer's SlimFit Vent Adapter.

### NOTICE

**USE SWEEP ELBOWS FOR ALL VENT AND AIR PIPING WHEN POSSIBLE** — Short-radius elbows cause higher pressure loss, resulting in less allowable vent/air piping length. See Figure 27, page 30 for maximum lengths and reductions required for fittings.

1. Install the vent manufacturer's SlimFit Vent Adapter in the boiler vent outlet. Follow all vent manufacturer instructions.
2. Install a vent manufacturer reducer if needed to adapt to the vent size being used.
3. Slope vent piping toward the boiler — slope vent piping a minimum of ¼ inch per foot in horizontal runs or larger per vent pipe manufacturer's instructions.
4. Support piping independently of the boiler — Install pipe supports every 5 feet on both the horizontal and vertical runs. Install a hanger support within 6 inches of any upturn in the piping. Or follow vent pipe manufacturer's instructions.

### Install vent termination fittings

1. Maintain the required dimensions of the finished termination piping as shown in Figure 32, page 37.
2. Air pipe penetration:
  - a. Cut a hole for the air pipe, sized per the vent/air pipe manufacturer's instructions.



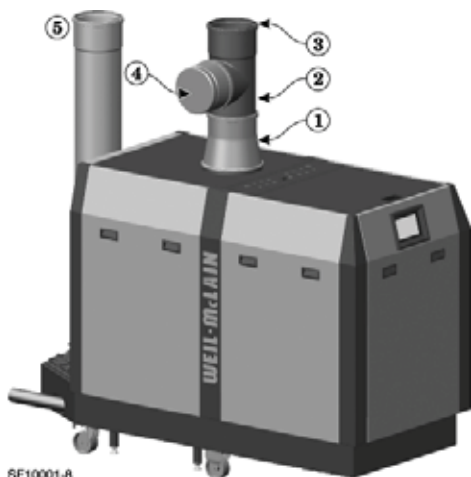
## DIRECT VENT — Sidewall *(continued)*

3. Vent pipe penetration:
  - a. Cut a hole for the vent pipe.
  - b. For combustible construction, size the vent pipe hole at least  $\frac{3}{8}$ " larger than the vent pipe diameter, or larger if specified by the vent manufacturer.
  - c. For noncombustible construction, size the opening per vent manufacturer instructions.
  - d. Insert a corrosion-resistant metal thimble in the vent pipe hole as shown in Figure 34.
  - e. Follow all local codes for isolation of vent pipe when passing through floors or walls.
4. Figure 42 — Provide and install corrosion-resistant metal stop plates (item 3) as shown.
  - a. The hole size in the stop plates must be just larger than the vent pipe diameter.
  - b. Obtain stop plates ONLY from the vent pipe manufacturer.
5. Insert the last lengths of vent and air pipe from the outside. The shoulders of the vent and air pipe female ends must rest against the outer stop plates as shown. The plates must prevent the vent or air pipe from being pushed inward.
6. The vent and air pipes may run up as high as 4 feet with no enclosure. The vent and air pipes must be secured with braces, and all clearances and lengths must be maintained. Space braces no further than 24 inches apart.
7. External venting greater than 4 feet requires an insulated enclosure around the vent and air pipes. The vent and air terminations must exit through the enclosure as shown in the illustration above, maintaining all required clearances.
8. Attach the exterior piping and termination elbows.
9. Install a vent/air pipe manufacturer's bird screen in the open end of the vent termination elbow and air termination elbow.
10. Seal exterior openings thoroughly with exterior caulk.
11. For multiple boiler terminations, see Figure 41.

### Provide access for cleaning the boiler air inlet

1. The boiler air inlet must be accessible for period examination and cleaning of the air inlet filter. This can be done by installing an 8-inch capped tee as shown in Figure 40 or by installing the air piping in a way that will allow disconnection of the air piping from the boiler air connection.
2. Install a pipe size reducer on top of the tee if using 6-inch air piping. DO NOT use a 6-inch tee.
3. Use only the air piping materials listed in Figure 28, page 31.

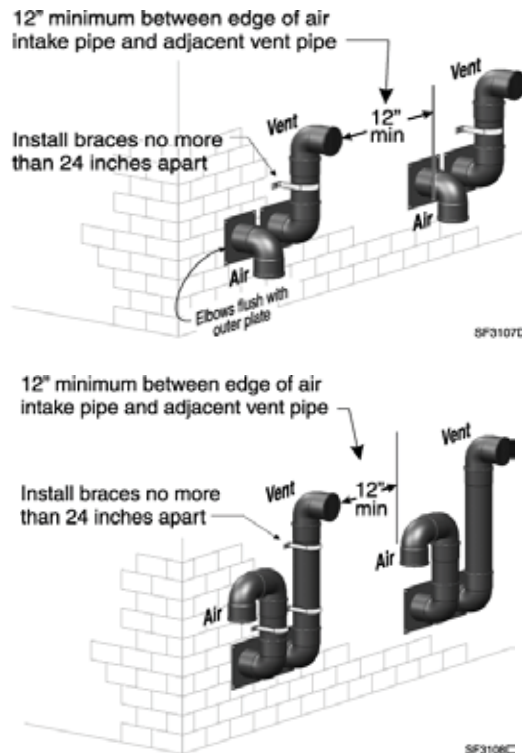
**Figure 40** Direct venting — install tee on air inlet or provide means to disassemble the air piping to allow access to the inlet air filter



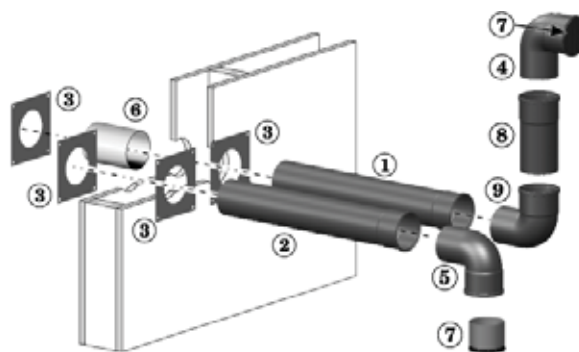
- 1 Vent/air pipe manufacturer's SlimFit Vent/Air Adapter, 8-inch outlet
  - 2 Vent/air pipe manufacturer's tee, 8-inch — orient the tee so the cover will be on the same side as the boiler heat exchanger cleanout cover
  - 3 Air pipe connection, 8-inch — add vent/air pipe manufacturer's reducer if using 6-inch air piping
  - 4 Vent/air pipe manufacturer's cover, 8-inch
  - 5 Vent piping (a vent/air pipe manufacturer's SlimFit Vent/Air Adapter must be installed at the boiler vent connection)
- Use only the vent/air piping materials listed in Figure 28, page 31.

SF10001-A

**Figure 41** Multiple terminations — clearance from vent of one to air intake of the next (normal and snorkel layouts)



**Figure 42** DIRECT VENT — sidewall termination assembly



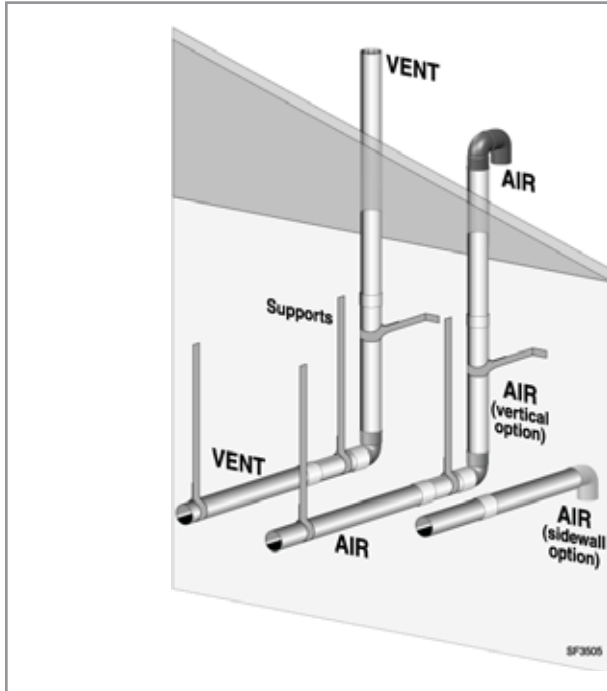
- 1 Vent piping — insert from the outside until the female end shoulder rests against the outside stop plate
- 2 Air piping — insert from the outside until the female end shoulder rests against the outside stop plate
- 3 Sidewall termination plates (hole must be just larger than the pipe diameter)
- 4 Vent termination elbow — use outward-facing 90-degree elbow as shown
- 5 Air termination elbow — use down-turned 90-degree elbow as shown
- 6 Corrosion-resistant thimble, by installer
- 7 Bird screens, by installer
- 8 Vent length
- 9 Elbow

SF063



## DIRECT VENT — Vertical

**Figure 43** Vertical direct vent terminations (air termination can be vertical or sidewall as shown below)



### ▲WARNING

**Use only the vent/air piping materials and kits listed in Figure 28, page 31.**

Read and follow all instructions in this manual. **DO NOT proceed with vent/air piping installation until you have read page 28 through page 33 and page 40 through page 42.**

Locate the termination such that the total vent piping from the boiler to the termination **will not exceed the maximum length given in Figure 27, page 30.**

**Comply with all vent system manufacturer's instructions.**

Provide a vent manufacturer's SlimFit Vent Adapter and reducer (if needed) at the boiler vent connection.

Every joint on **polypropylene vent piping must** include a locking collar. Failure to supply locking collars could result in vent/air piping leakage.

### Determine termination location

1. The vent and air terminations must be installed as shown in Figure 43. The air termination can be either through the roof or through a side wall, as shown.
2. The termination placement must comply with clearances and limitations shown in Figure 31, page 36.
3. Locate the terminations so they are not likely to be damaged by foreign objects, such as stones or balls, or subject to buildup of leaves or sediment.
4. Provide means to access the boiler air inlet as instructed on page 46.
5. Install the boiler in a location that allows proper routing of all vent and air piping from the boiler vent and air connections to the selected termination locations.

**▲WARNING** Do not exceed the maximum lengths of the outside vent and air piping shown in Figure 44, page 46. Excessive length exposed to the outside could result in freezing of condensate in the vent pipe or vent/air piping failure. Follow vent/air pipe manufacturer's instructions for proper protection and support of the piping and for installations in very cold climates.

### Multiple vent terminations

1. When terminating multiple SlimFit boilers, terminate each vent connection as described in this manual. When using sidewall air terminations, place terminations at least 6 inches apart.

**▲WARNING** Terminate all vent pipes at the same height and all air pipes at the same height to avoid possibility of severe personal injury, death or substantial property damage.

2. Place roof penetrations to obtain minimum clearance of 12 inches between edge of air intake elbow and adjacent vent pipe of another boiler for U. S. installations (see Figure 45, page 46).
3. For Canadian installations, provide clearances required by CAN/CSA B149.1 Installation Code and a ULC S636 compliant vent kit.

### Install vent piping

#### ▲WARNING

See **WARNING** about boiler vent/air outlet seals and vent clamp on page 29. Verify that the seal is installed correctly before inserting the vent manufacturer's SlimFit Vent Adapter.

#### NOTICE

**USE SWEEP ELBOWS FOR ALL VENT PIPING WHEN POSSIBLE** — Short-radius elbows cause higher pressure loss, resulting in less allowable vent/air piping length. See Figure 27, page 30 for maximum lengths and reductions required for fittings.

1. Install the vent/air pipe manufacturer's SlimFit Vent Adapter in the boiler vent and air outlets. Follow all vent/air pipe manufacturer's instructions.
2. Install a vent/air pipe manufacturer's reducer if needed to adapt to the vent size being used.
3. Slope vent piping toward the boiler — slope vent piping a minimum of ¼ inch per foot in horizontal runs or larger per vent pipe manufacturer's instructions.
4. Support piping independently of the boiler — Install pipe supports every 5 feet on both the horizontal and vertical runs. Install a hanger support within 6 inches of any upturn in the piping. Or follow vent/air pipe manufacturer's instructions.

## DIRECT VENT — Vertical *(continued)*

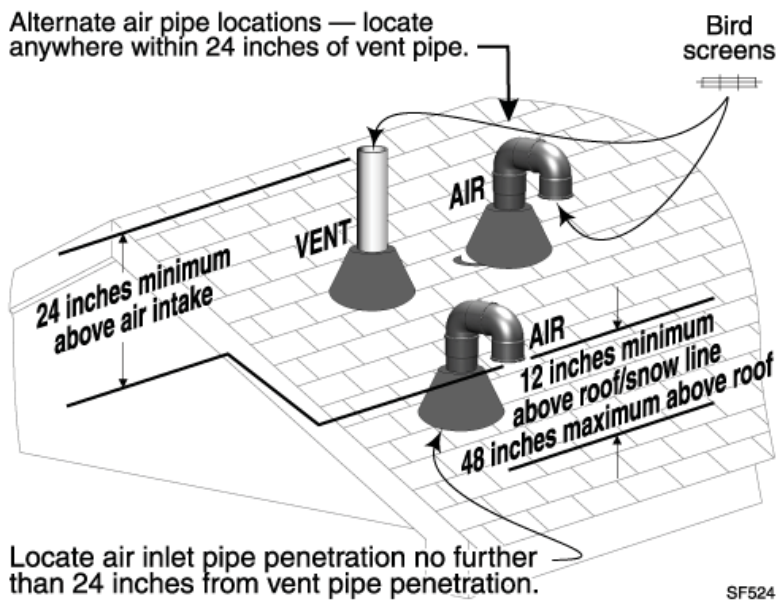
### Install vent and air terminations

1. Air pipe penetration
  - a. Cut a hole for the air pipe, sized per the vent/air pipe manufacturer's instructions.
2. Vent pipe penetration:
  - a. Cut a hole for the vent pipe.
  - b. For combustible construction, size the vent pipe hole at least  $\frac{3}{8}$ " larger than the vent pipe diameter, or larger if specified by the vent manufacturer.
  - c. For noncombustible construction, size the opening per vent manufacturer instructions.
  - d. Insert a corrosion-resistant metal thimble in the vent pipe hole.
  - e. Follow all local codes for isolation of vent pipe when passing through floors, ceilings and roofs.
3. Vertical terminations, both vent and air
  - a. Provide flashing and sealing boots sized for the vent pipe.
  - b. Use a coupling or open-end pipe termination, following vent manufacturer's guidelines for vertical terminations.
  - c. Install a vent/air pipe manufacturer's bird screen in the open ends of the terminations.
  - d. Maintain the required dimensions of the finished termination piping as shown in Figure 44.
4. Vertical vent termination with sidewall air termination
  - a. See Figure 46, page 47.
  - b. Figure 47, page 47 — Provide and install corrosion-resistant metal stop plates (item 3) as shown.
  - c. The hole size in the stop plates must be just larger than the vent pipe diameter.
  - d. Obtain stop plates ONLY from the vent pipe manufacturer.
  - e. Insert the last length of air pipe from the outside. The shoulder of the air pipe female end must rest against the outer stop plate as shown. The plate must prevent the air pipe from being pushed inward.
  - f. Insert the termination elbow into the air pipe end.
  - g. Install a vent manufacturer's bird screen in the open end of the vent termination elbow.
  - h. Seal exterior openings thoroughly with exterior caulk.

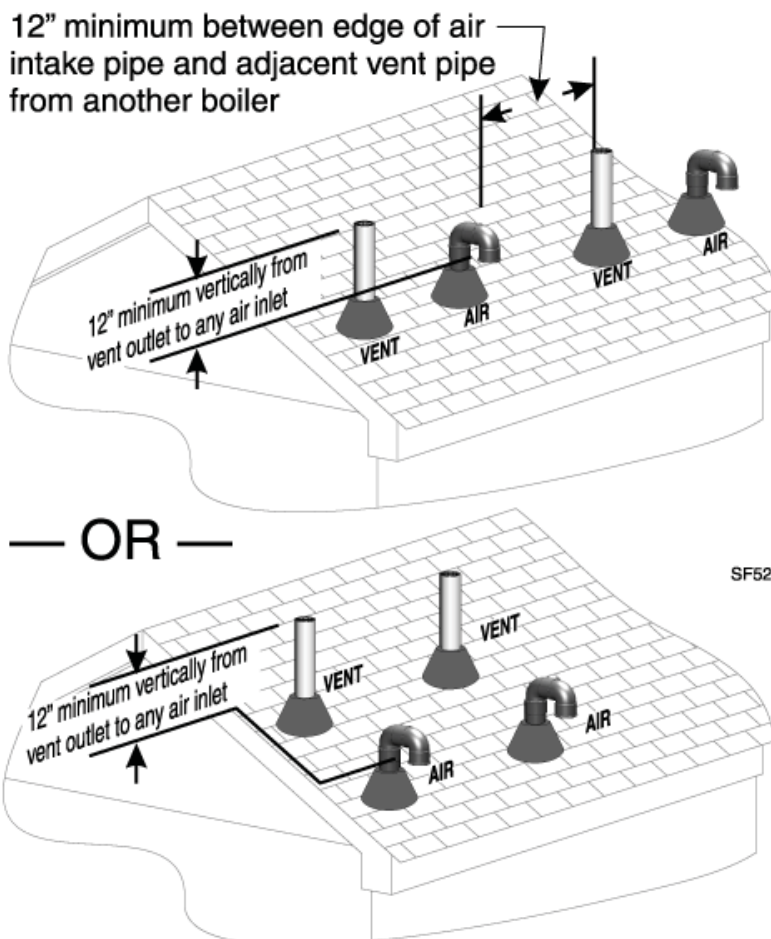
### Provide access for cleaning the boiler air inlet

1. The boiler air inlet must be accessible for periodic examination and cleaning of the air inlet filter. This can be done by installing an 8-inch capped tee as shown in Figure 48 or by installing the air piping in a way that will allow disconnection of the air piping from the boiler air connection.
2. Install a vent/air pipe manufacturer's reducer on top of the tee if using 6-inch air piping. DO NOT use a 6-inch tee.
3. Use only the air piping materials listed in Figure 28, page 31.

**Figure 44** Vertical vent and air terminations



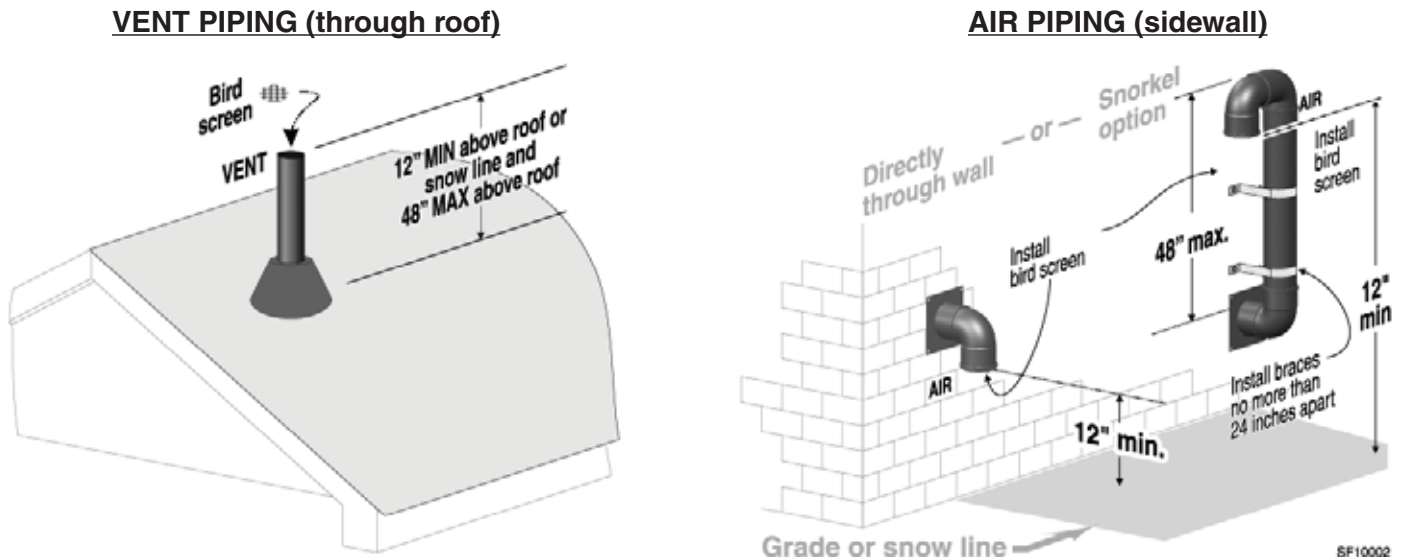
**Figure 45** Termination location — multiple boilers — vent and air piping vertical





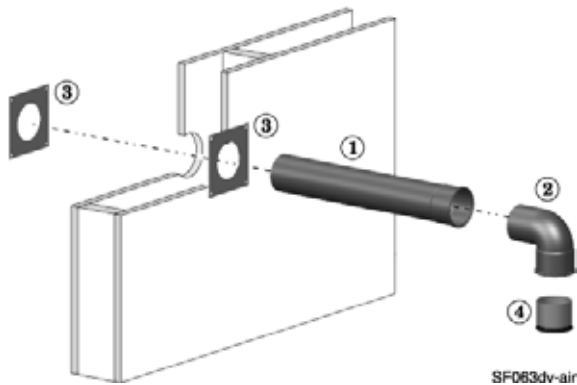
# DIRECT VENT — Vertical *(continued)*

**Figure 46** Termination location — multiple boilers — vertical vent/sidewall air



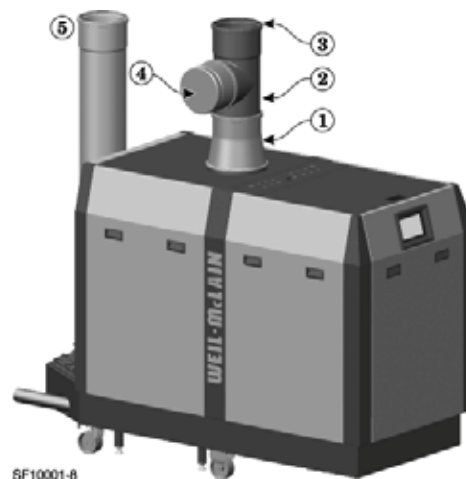
**Multiple boiler applications** — Space vents minimum 6 inches apart. Space air terminations minimum 6 inches apart.

**Figure 47** Sidewall air termination assembly — vertical vent with sidewall air



- 1 Air piping — must extend through wall enough for complete engagement of the air termination elbow
- 2 Air termination elbow — must be down-turned 90-degree elbow
- 3 Sidewall termination plates (hole must be just larger than the air pipe diameter)
- 4 Bird screen, by installer

**Figure 48** Direct venting — install tee on air inlet or provide means to disassemble the air piping to allow access to the inlet air filter



- 1 Vent/air pipe manufacturer's SlimFit Vent/Air Adapter, 8-inch outlet
  - 2 Vent/air pipe manufacturer's tee, 8-inch — orient the tee so the cover will be on the same side as the boiler heat exchanger cleanout cover
  - 3 Air pipe connection, 8-inch — add vent/air pipe manufacturer's reducer if using 6-inch air piping
  - 4 Vent/air pipe manufacturer's cover, 8-inch
  - 5 Vent piping (a vent/air pipe manufacturer's SlimFit Vent/Air Adapter must be installed at the boiler vent connection)
- Use only the vent/air piping materials listed in Figure 28, page 31.

# Install condensate components

## Assemble condensate trap

1. Remove condensate trap parts from the trim bag.
2. See Figure 49. Slip the flexible coupling (item 4) over the trap outlet as shown.
3. Slide the two hose clamps over the flexible coupling.
4. Tighten one clamp to secure the coupling to the condensate trap.
5. Tighten the other clamp just enough to keep it in place on the flexible coupling until the condensate line has been installed.

## Install the condensate trap

1. See Figure 50.
2. Insert the condensate trap inlet gasket (Figure 49, item 6) into the inlet ferrule (Figure 49, item 2).
3. Slide the condensate trap inlet over the boiler condensate outlet, located at the lower front center of the boiler.
4. Tighten the ferrule securely by hand.
5. Rotate the condensate trap support leg (Figure 49, item 3) to extend the support leg down until it touches the floor and the trap is level.

## Connect condensate line

1. Use 1" PVC or CPVC pipe to route condensate to a drain or condensate pump.

### NOTICE

Use materials approved by the authority having jurisdiction. In the absence of other authority, PVC and CPVC pipe must comply with ASTM D1785, F441 or D2665. Cement and primer must comply with ASTM D2564 or F493. For Canada, use CSA or ULC certified PVC or CPVC pipe, fittings and cement.

2. If installing a condensate pump, select one approved for use with condensing boilers and furnaces. The pump should have an overflow switch to prevent property damage from condensate spillage. See Figure 51 for required flow capacity. Provide an external power source for the condensate pump.
3. When sizing condensate pumps, make sure to include the total load of all SlimFit boilers connected.

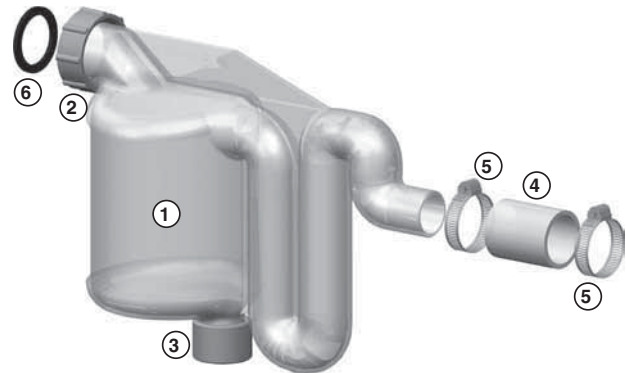
### WARNING

The condensate line must remain unobstructed, allowing free flow of condensate. If condensate is allowed to freeze in the line or if the line is obstructed in any other manor, condensate can back up into the boiler, eventually leading to boiler lockout.

### NOTICE

Condensate from the SlimFit boiler will be slightly acidic (typically with a pH from 3.2 to 4.5). Install a neutralizing filter if required by local codes. See Replacement parts section at the end of this manual for a Weil-McLain condensate neutralizer kit.

Figure 49 Condensate trap assembly



- 1 Condensate trap body
- 2 Condensate trap inlet connection
- 3 Adjustable support foot
- 4 Flexible coupling on trap outlet connection (for use with 1-inch PVC or CPVC pipe)
- 5 Hose clamps (2)
- 6 Condensate trap inlet gasket

Figure 50 Condensate trap assembly, installed

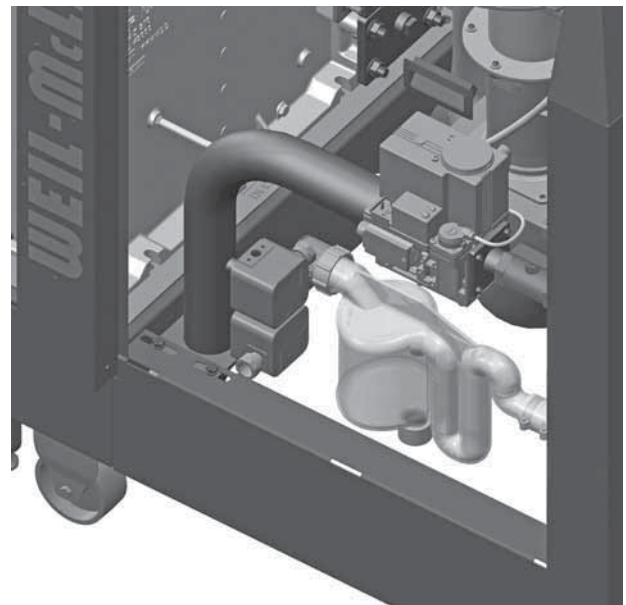


Figure 51 Condensate pump capacity, GPH

Minimum recommended condensate pump capacity per boiler, GPH	
SF1000	27
SF1500	40
SF2000	54





## Gas piping

**⚠WARNING** DO NOT connect the SlimFit boiler to a propane supply. The boiler is suitable for firing ONLY natural gas. Failure to comply could result in severe personal injury, death or substantial property damage.

### Connecting gas supply piping

1. See Figure 52.
2. Connect gas supply piping to the boiler.
  - a. Install a union for servicing, when required.
  - b. Install a manual shutoff valve in the gas supply piping, within 6 feet of the boiler.
  - c. In Canada, the manual gas valve must be identified by the installer.
3. Support gas piping with hangers or other devices, not by the boiler or its accessories.
4. Use pipe dope compatible with propane gases (because natural gas may contain some propane). Apply sparingly only to male threads of pipe joints so that pipe dope does not block gas flow.

**⚠WARNING** Failure to apply pipe dope as detailed above can result in severe personal injury, death or substantial property damage.

**⚠WARNING** Install a 100% lockup gas pressure regulator in the gas supply line if inlet pressure can exceed 14" w.c. at any time. Adjust the lockup regulator for 7 to 10" w.c. inlet pressure. This setting provides a cushion below the setting of the high gas pressure switch. Failure to comply could result in shutdown by the high gas pressure switch, resulting in possible serious property damage due to freeze-up.

### Check gas supply

1. Purge all air from the gas supply piping.
2. Before placing the boiler in operation, check the boiler and its gas connection for leaks.
  - a. Close manual main shutoff valve during any pressure testing at less than 20" w.c.
  - b. Disconnect the boiler gas connection from the gas supply piping during any pressure testing greater than 20" w.c.

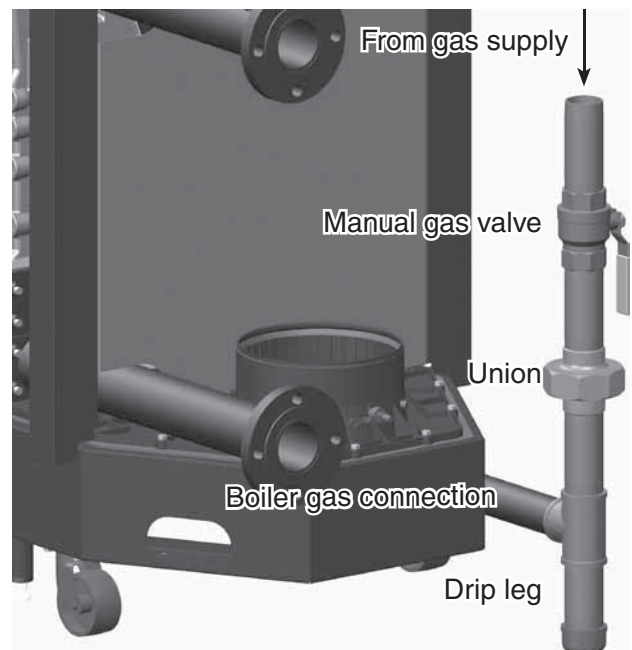
**⚠WARNING** Do not check for gas leaks with an open flame — use a soapy water bubble test. Failure to eliminate gas leaks can cause severe personal injury, death or substantial property damage.

### Check gas supply pressure

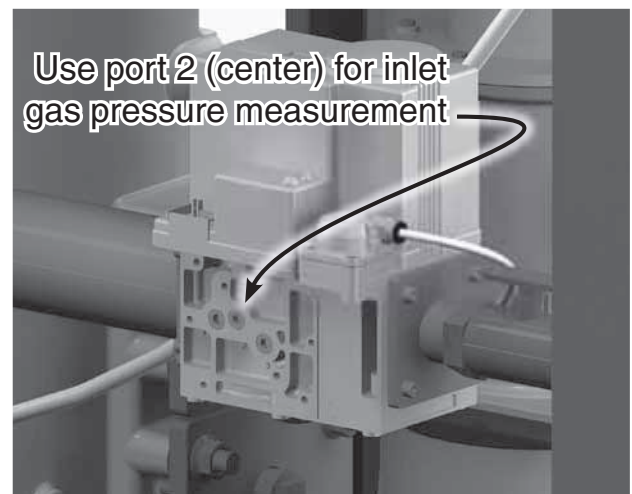
1. See Figure 53. Connect a manometer or pressure gauge to the 1/8-inch Port 2 on the side of the gas valve (available on both sides of valve).
2. The pressure required at gas valve inlet pressure port (verify minimum gas pressure when all gas appliances are in operation):
  - a. Minimum gas pressure, with gas flowing — 3" w.c. (76 mm) — verify during boiler startup, while boiler is at high fire.
  - b. Maximum: certified to 14" w.c. (355 mm) with no flow (lockup) or with boiler on. Set the supply gas pressure regulator so the supply pressure is far enough below 14" w.c. to ensure that varying pressure conditions won't trip the high gas pressure switch (set at 14" w.c.).

**⚠WARNING** Use two wrenches when tightening gas piping at boiler, using one wrench to prevent the boiler gas line connection from turning. Failure to support the boiler gas connection pipe to prevent it from turning could damage gas line components.

**Figure 52** Connect gas supply piping (all fittings and gas valve supplied by installer)



**Figure 53** Gas valve inlet pressure tap (available on both sides of the gas valve)





# Gas piping *(continued)*

## Pipe sizing

1. Size gas supply piping from meter outlet to entrance of boiler in accordance with Figure 54 and Figure 55.
2. Use the total input of all connected appliances. Divide the total input in Btuh by 1,000 to obtain approximate cubic feet per hour of natural gas.
  - a. Pipe lengths in Figure 54 are equivalent lengths of straight pipe. Use Figure 55 to determine equivalent length of fittings.
  - b. Figure 54 is only for natural gas with specific gravity 0.60, with a pressure drop through the gas piping of 0.30" w.c.
  - c. For additional gas pipe sizing information, refer to ANSI Z223.1/NFPA54 (or CAN/CSA B149.1 for Canadian installations).

## Multiple boiler applications — manifolded gas supply lines

1. Size gas supply piping as instructed above.
2. At each boiler, provide a manual shutoff gas valve, union and sediment trap (minimum 3 inches below tee) as shown in Figure 52, page 49.
3. Ensure the piping is large enough so that the minimum pressure at each boiler, with all connected appliances firing, will be as specified on page 49.

## Gas pressure switches

1. SlimFit boilers are equipped with manual reset high gas pressure and low gas pressure switches (see Figure 53, page 49).
2. These switches are factory set and should remain at the following settings:
  - a. High gas pressure: 14 inches w.c.
  - b. Low gas pressure: 2 inches w.c.

**NOTICE** The low gas pressure switch must be manually reset (button on front of switch) on initial startup or any time the gas supply is turned off.

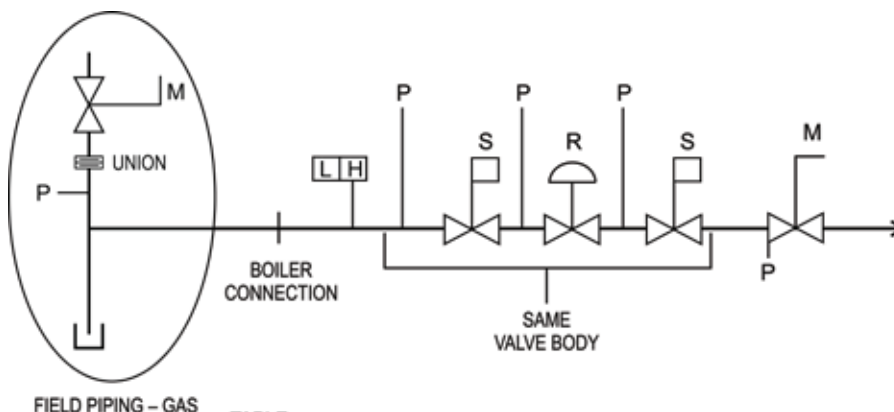
**Figure 54** Pipe capacity for natural gas

Gas pipe total length (feet)	Gas supply pipe capacity (cubic feet per hour) @ 0.30" w.c. pressure drop (cubic feet per hour, 0.60 specific gravity)				
	1½"	2"	2½"	3"	4"
10	1600	3050	4800	8500	17500
20	1100	2100	3300	5900	12000
30	890	1650	2700	4700	9700
40	760	1450	2300	4100	8300
50	670	1270	2000	3600	7400
70	560	1050	1700	3000	6200
100	460	870	1400	2500	5100
150	380	710	1130	2000	4100

**Figure 55** Equivalent lengths of straight pipe for gas line fittings

Pipe size inches	Equivalent length, feet	
	90° Elbow	Tee
1½	4.02	8.04
2	5.17	10.3
2½	6.16	12.3
3	7.67	15.3
4	10.1	20.2

## Gas Train Diagram



**TABLE**

S = SAFETY SHUT-OFF VALVE	L = LOW GAS PRESSURE SWITCH
R = ZERO GOVERNOR REGULATOR	H = HIGH GAS PRESSURE SWITCH
M = MANUAL SHUT-OFF VALVE	P = PRESSURE TAP



## Field wiring (see Figure 57 & Figure 58)

**⚠ WARNING ELECTRICAL SHOCK HAZARD** — For your safety, turn off electrical power supply at service entrance panel before making any electrical connections to avoid possible electric shock hazard. Failure to do so can cause severe personal injury or death.

**NOTICE** Wiring must be N.E.C. Class 1. If original wiring as supplied with boiler must be replaced, use only type 105 °C wire or equivalent. Boiler must be electrically grounded as required by National Electrical Code ANSI/NFPA 70 – latest edition.

### Installation must comply with:

1. National Electrical Code and any other national, state, provincial or local codes or regulations.
2. In Canada, CSA C22.1 Canadian Electrical Code Part 1, and any local codes.

### Wiring — general

1. All field wiring connects to the labeled terminal strips on top of the SlimFit boiler. See page 3 for location. The terminal strip sections are labeled A, B, C, D, E and F.
2. See the schematic diagram (Figure 57, page 52) & ladder diagram (Figure 58, page 54).
3. The Sola control provides programmable flexibility in system operation, allowing control and operating setup for up to three pumps.
4. Read this manual thoroughly before connecting the wiring to ensure trouble-free startup and operation.

### Wiring — overview

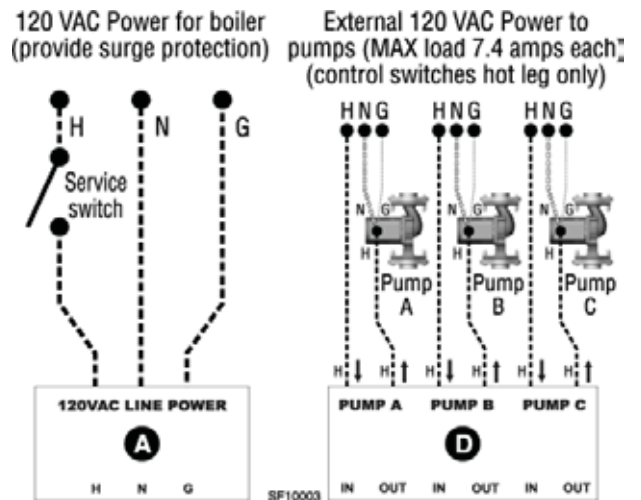
You will need to make the following connections, some of which depend on your system and how the Sola will be programmed. (*See this and following pages for more information.*)

- ❑ **Connect 120VAC power for boiler**
  - Provide a fused (or breaker) power supply that includes a surge arrestor.
- ❑ **Connect wiring for up to three pumps**
  - Each pump circuit provides a dry contact to be wired in the HOT line voltage wiring to the pump. Each pump requires an external 120 VAC/Single-phase power supply.
- ❑ **Connect external limits and interlocks, if used**
  - Three different circuits are available — Manual reset limit operation (ILK circuit); automatic reset limit operation (LCI circuit); and pre-ignition interlocks (PII circuit).

- ❑ **Connect thermostats and/or heat demand contacts**
  - The Sola can regulate the boiler for up to two different heating systems (space heating and DHW, for example).
- ❑ **Other connections**
  - Temperature sensors — Outdoor sensor and system sensor — when used. The boiler is shipped with an outdoor sensor and a system supply sensor. The system supply sensor will be required for lead/lag systems and for primary/secondary-piped single boiler systems.
  - Time of day contact —
  - Remote alarm — Dry contact for remote alarm circuit.
  - Multiple boiler connection — Modbus cable connection to other boilers in lead/lag system.
  - BMS input — Modbus cable for Modbus input or for Bacnet converter.
  - Analog input — The Sola will operate and modulate the boiler based on a 4–20 mA control signal from a remote controller, when desired.
  - Analog rate monitoring — 4–20 mA or 0–10 VDC.

### Line voltage power input

**Figure 56** Line voltage and pump connections (terminal strips A and D)



1. Boiler line voltage power — Boiler load: SF1000 — 4.9 amps; SF1500 — 13.5 amps; SF2000 — 16.0 amps.. Provide and install a fused disconnect or service switch as required by applicable codes. Fuse or breaker rating must not exceed 20 amps.
2. Pump activation circuits — Provide external power for pumps, 120 VAC/1-phase, sized as required for the pump loads. Interrupt each pump's hot line with the connections on terminal strip D.

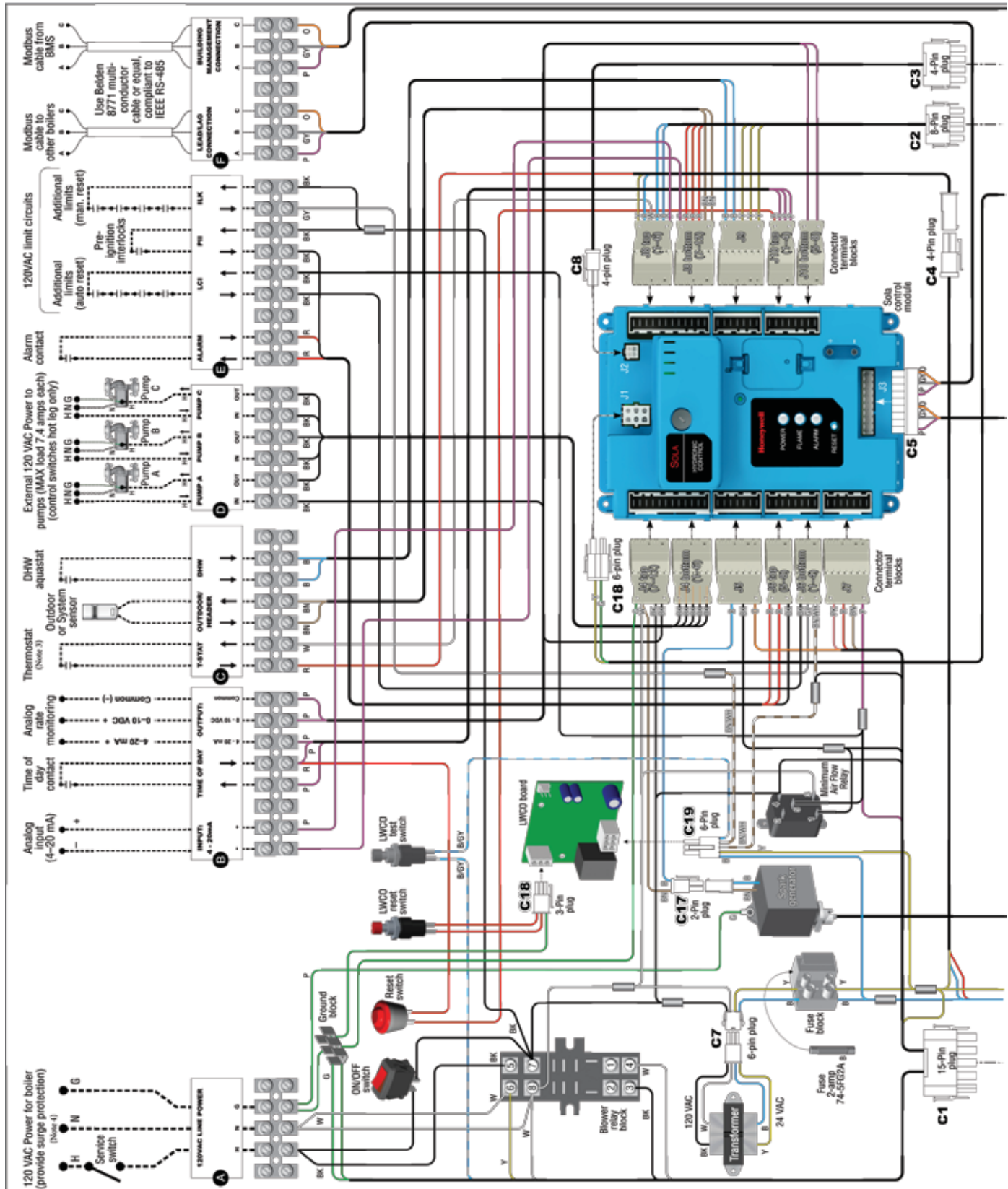
Continued after page 54



# Field wiring (see Figure 57 & Figure 58) (continued)



Figure 57 Schematic wiring diagram — SlimFit boilers (continued on next page)

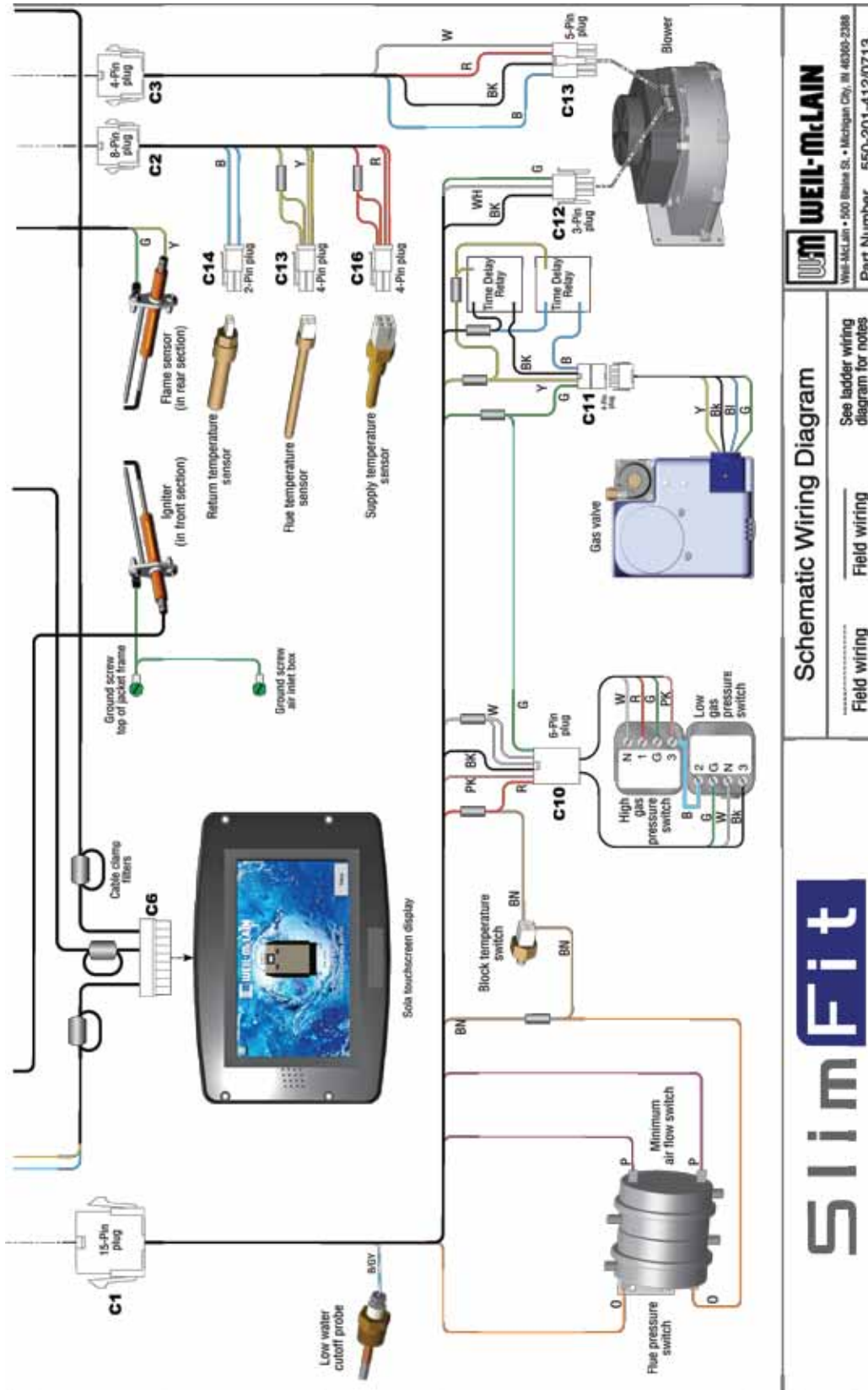




# Field wiring (see Figure 57 & Figure 58) (continued)



Figure 57 (continued from previous page) Schematic wiring diagram — SlimFit boilers



**Schematic Wiring Diagram**

Field wiring      Field wiring

See ladder wiring diagram for notes

**WEIL-McLAIN**

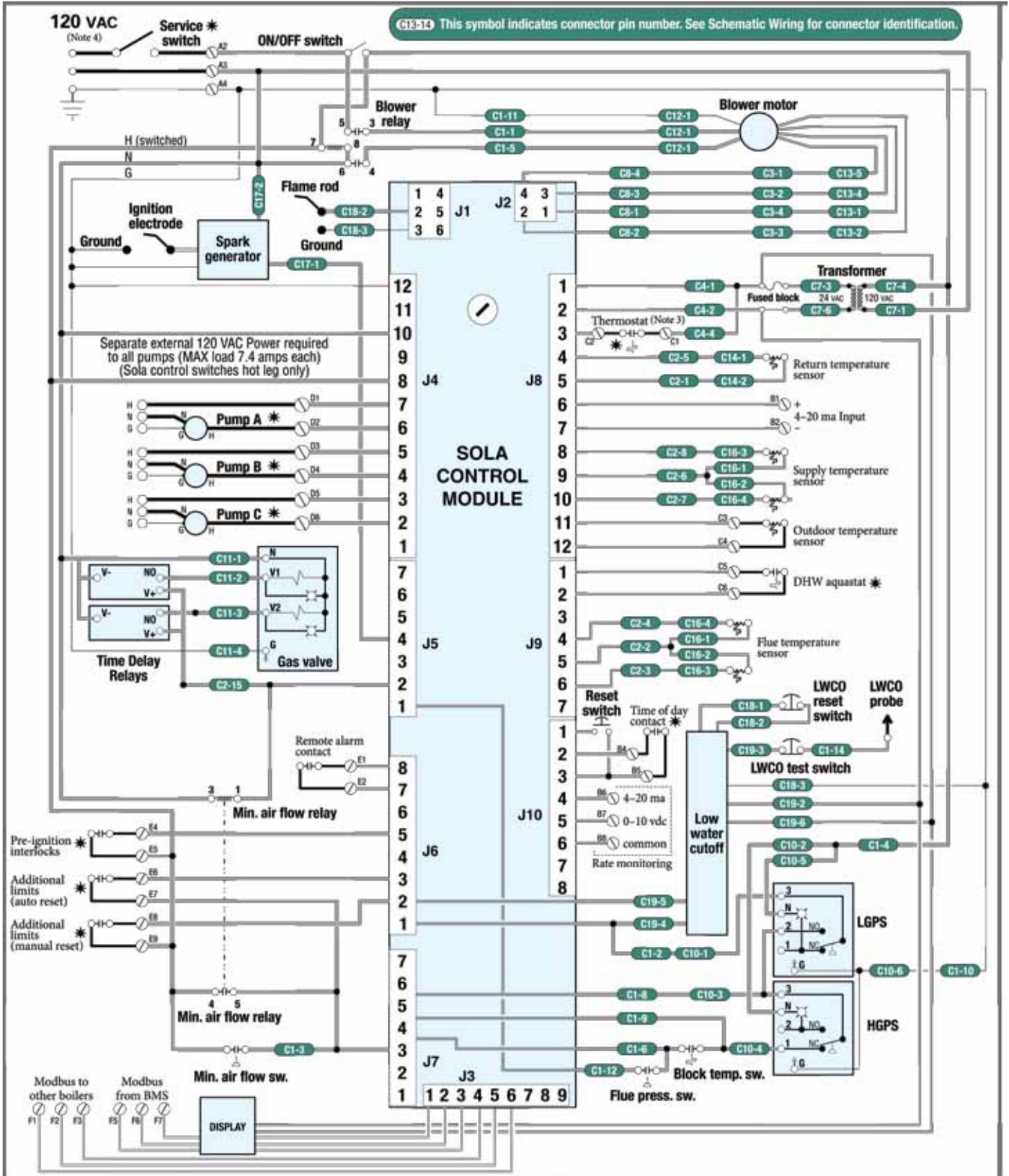
WEIL-McLAIN • 500 Blake St. • Michigan City, IN 46360-2888

Part Number 550-201-412/0713



# Field wiring (see Figure 57 & Figure 58) (continued)

Figure 58 Ladder wiring diagram — SlimFit boilers (continued on next page)





# Field wiring (see Figure 57 & Figure 58) *(continued)*

Figure 58 (continued from previous page) Ladder wiring diagram — SlimFit boilers

## Ladder Wiring Diagram

**⚠ WARNING**

**Electrical shock hazard — can cause severe injury or death. Disconnect power before installing or servicing.**

**NOTICE**

All contacts shown without power applied.

✳ Indicates items not provided

**Legend for ladder wiring diagram only**

- 120 vac field wiring
- Low voltage field wiring
- 120 vac factory wiring
- Low voltage factory wiring
- High voltage spark ignition wiring
- Ground connectors

**Notes for Schematic and Ladder Wiring Diagrams**

1. All wiring must be installed in accordance with:
  - U.S.A. — N.E.C. And any other national, state, or local code requirements.
  - Canada — C.S.A. C22.1 C.E.C. Part 1 and any other national, provincial, or local code requirements.
2. If any of the original wire as supplied with the appliance must be replaced, use minimum 105 °C wire or equivalent. Exceptions: Ignition lead wire must be obtained from Weil-McLain only.
3. Thermostat anticipator setting (single zone) — set anticipator for 0.1 amps.
4. Provide power source to boiler that is protected by a surge protector. Amperage requirements for boilers are:
  - SF1000 — 4.9 amps
  - SF1500 — 13.5 amps
  - SF2000 — 16.0 amps

Fuse or breaker rating must not exceed 20 amps.

Weil-McLain • 500 Blaine St. • Michigan City, IN 46360-2388

Part Number 550-201-424/0813



## Field wiring (see Figure 57 & Figure 58) (continued)

### Pumps (Terminal strip D)

1. The Sola provides for connection of up to three pumps.
2. The Sola control must be programmed to determine when these pumps operate. Factory default setup is outlined in the following.

**WARNING** Pumps A, B and C — **The maximum allowable current for each pump is 7.4 amps at 120 VAC.** For pumps with higher amp ratings, you must install a relay or starter to operate the pump. For pumps rated over 7.4 amps, connect only the pump relay or starter coil to the SlimFit pump terminals.

Pumps require an external 120 VAC/1-ph power supply. DO NOT power any pump from the boiler terminals. You can connect any of the pumps you use to any of the three pump activation terminals. The Sola setup allows you to assign which pumps activate on a call for heat (this can be customized for each of the heating systems supplied by the boiler).

### Factory default pump assignments

1. Pump A — **BOILER** pump
  - a. Programmed to operate only on space heating, not on DHW.
2. Pump B — **SYSTEM** pump (space heating)
  - a. Programmed to operate only on space heating, not on DHW.
3. Pump C — **DHW** pump
  - a. For direct-connected DHW, NOT for DHW in the system as a zone.

### Thermostats & DHW tank temperature control connections (Terminal strip C)

1. Connect the space heating thermostat or dry contact to terminal strip C “T-STAT” terminals.
2. Install thermostats on inside walls away from the influences of drafts, hot or cold water pipes, lighting fixtures, television, sun rays, or fireplaces.
3. Thermostat anticipator (if applicable):
  - If connected directly to the boiler, set anticipator for 0.1 amps.
  - If connected to relays or other devices, set to match total electrical power requirements of connected devices. See device manufacturers’ specifications and the thermostat instructions for details.
4. Connect a DHW aquastat to terminal strip C “DHW aquastat” terminals.

### Additional limits and interlocks (Terminal strip E)

**WARNING** All three of the terminal strip E limit circuits are 120 VAC. Limits must be rated for 120 VAC and wired per code requirements.

1. **Manual reset (ILK circuit)**
  - a. Limit controls wired between the terminal strip E “ILK” terminals will cause a manual reset when they open.

**NOTICE** The Sola control will lockout when a limit in its manual reset circuit (ILK) opens. The Sola control activates its alarm terminals and shuts the boiler down until an operator manually resets the Sola reset button. Reset will occur if the condition has been corrected.

2. **Automatic reset (LCI circuit)**
  - a. Limit controls wired between the terminal strip E “LCI” terminals will cause automatic reset operation.
  - b. The Sola control will shut the boiler down. It will restore operation automatically once the condition is corrected and the LCI circuit closes.
3. **Pre-ignition interlocks (PII circuit)**
  - a. Devices wired between the terminal strip E “PII” terminals will prevent the boiler from starting until the circuit closes.
  - b. The control will only monitor this circuit BEFORE the boiler has started firing.

### Low water cutoff (Factory wired in boiler)

1. SlimFit Commercial boilers are equipped with a manual reset low water cutoff, with its probe in the upper right of the burner end section. The lwco control board is mounted in the control box.
  - a. The low water cutoff is wired to the Sola and requires a manual reset if tripped.
  - b. The low water cutoff is also wired to a push-to-test button.
  - c. Both low water cutoff buttons are accessible on the top of the boiler jacket.

### Remote setpoint or modulation

(Terminal strip B)

1. Connect the 4–20 mA output from an external controller to terminal strip B “INPUT: 4–20mA” terminals to control either temperature setpoint or firing rate modulation.
2. The setpoint option is a useful way to allow a single boiler on a primary/secondary system to control system temperature with the system sensor, but operate on temperature reset using an external reset controller.

### Analog rate monitoring (Terminal strip B)

1. Connect to the 4–20 mA or 0–10 VDC terminals on terminal strip B for remote monitoring of boiler modulation level.

### Alarm contacts (Terminal strip E)

1. Boiler comes with dry alarm contacts (terminal E) that can be used to activate a remote alarm (visual and/or audible alarms provided by others).

### Outdoor temperature sensor (Terminal strip C)

1. The outdoor sensor is shipped loose with the boiler.
2. When the outdoor sensor is connected, the target boiler space heating supply temperature will change with outdoor temperature.
3. The Sola control is factory programmed to use this input for outdoor reset. The control can be programmed to use the input for a system supply sensor instead.





## Field wiring (see Figure 57 & Figure 58) (continued)

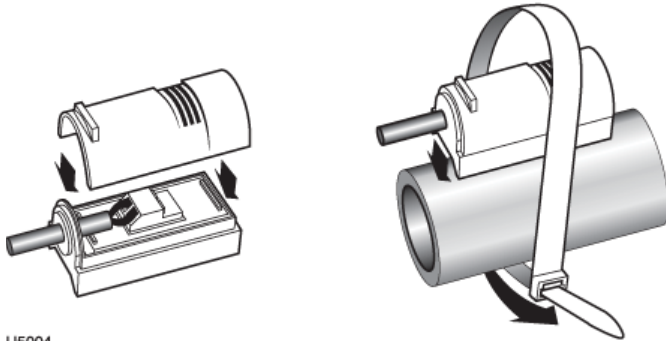
### NOTICE

On single-boiler applications, the outdoor sensor cannot be used if a system sensor is attached. On multiple boiler systems, the system sensor can be attached to the master boiler and the outdoor sensor attached to one of the slave boilers.

- Thermostat wire can be used to connect the sensor.

### System supply sensor (Terminal strip C)

- The system supply sensor is shipped loose with the boiler.



U5004

- The system supply temperature sensor allows the Sola to regulate temperature in the system main piping, either for primary/secondary-piped single-boiler systems or for multiple-boiler systems.

### NOTICE

On single-boiler applications, the system sensor cannot be used if an outdoor reset sensor is attached (unless a separate outdoor reset controller is purchased and installed).

On multiple boiler systems, the system sensor can be attached to the master boiler and the outdoor sensor attached to one of the slave boilers. The Sola control parameters must be set accordingly.

- Locate the supply sensor at least six pipe diameters, but no more than 10 pipe diameters, downstream from the boiler supply connection to the main to ensure adequate mixing.
- Thermostat wire can be used to connect the sensor.

### Time of day operation (Terminal strip B)

- The Sola control can be programmed to change setpoint whenever the time of day contact closes.
- Connect a dry contact across terminal strip B “TIME OF DAY” terminals to use this function.

### Combustion air damper interlock (if used)

### NOTICE

The Sola control can be used to operate a combustion air damper **ONLY if one of the pump outputs is available**.

If a pump output is **NOT** available, activate an external relay on call for boiler operation from any source (space heating, DHW or other). Use one of the relay contacts to start the combustion air damper. Wire the combustion air damper end switch in the boiler’s LCI circuit, terminal strip E.

- The Sola control is factory programmed to use the Auxiliary 1 pump function to operate the combustion air damper.
- The damper end switch must be connected in the Sola control automatic reset limit circuit (LCI terminals of terminal strip E).
- The following Sola control parameters must be set:
  - Determine which of the pump outputs on terminal strip D will be used for the damper motor. The factory default setting assigns pump A as the boiler pump and pump C as the system pump. The simplest choice is to assign pump B as the combustion air damper motor output.
  - To assign the pump output, go to CONFIGURE → PUMP CONFIGURATION. Toggle the pump display to AUXILIARY 1 PUMP. Press PUMP OUTPUT and select which pump to assign (A, B or C).

### Multiple boiler wiring (Terminal strip F)

- Connect to terminal strip F “LEAD/LAG CONNECTION” terminals.
- Wire from boiler to boiler using twisted 3-wire cable. Do not exceed 600 feet in this wiring. Termination resistors may be needed for long runs.
- The Sola control uses Modbus communications to operate and receive input from all of the boilers in the system.

### Building management system input (Terminal strip F)

- Connect one cable from the building management system to terminal strip F “BUILDING MANAGEMENT CONNECTION” terminals on the master boiler only.
- Connect from boiler to boiler by connecting to the terminal strip F “LEAD/LAG CONNECTION” terminals of each boiler.
- Use Belden 8771 multi-conductor cable or equal, compliant to IEEE RS-485.
- If the BMS uses BACnet protocol, install a BACnet converter between the BMS and the SlimFit BMS input terminals.



# Sola control overview & sequence of operation



**Temperature settings** — You must ensure that the Sola is set for the proper water temperatures for the system. Excessive water temperature can cause significant property damage in some applications.

**Multi-temperature systems** — If the heating system includes circuits that require lower temperature water (radiant slab circuits, for example) as well as higher temperature circuits (DHW, finned tube baseboard, etc.), it is recommended to protect low-temperature circuits with limit controls that are wired to a Sola external limit circuit. Failure to provide regulation can result in substantial property damage.

## Sola overview

The Sola is fully programmable to meet system requirements, allowing supply water regulation for central heating (CH) and domestic hot water heating (DHW).

Some of the Sola features:

- Blower speed modulation to control the SlimFit boiler's firing rate.
- Advanced PID response to anticipate system needs based on response to heat input.
- Graphic and robust touch-screen display for ease of operation, monitoring and troubleshooting.
- Control of up to three pumps.
- Programmable priority assignments.
- Integral outdoor reset option.
- 4–20 mA analog input for remote setpoint or modulation control.
- 4–20 mA or 0–10 VDC output for remote firing rate monitoring.
- Multiple boiler sequencing.
- Factory-installed temperature sensors for boiler in, heat exchanger, boiler out and flue.
- The boiler is equipped with a low water cutoff, factory wired to the Sola control, manually reset through the device and the Sola control.
- The boiler is shipped with an outdoor sensor and strap-on system supply sensor for field installation.

## Sequence of operation

### Initiation sequence

1. The Sola control enters the Initiate sequence on Initial Power up or under the following conditions:
  - a. If Demand, LCI, or STAT interrupts (opens) during the Prepurge Period.
  - b. After the reset button is pressed or a fault is cleared at the display.
2. The Initiate sequence also delays the burner motor from being energized and de-energized from an intermittent AC line input or control input.
3. If an AC line problem exists for more than 240 seconds, a lockout will occur.

### Space Heating (CH) operating sequence

1. Heat request detected (On Setpoint – On Hysteresis).
2. The space heating pump(s) is switched on.
3. After a system Safe Start Check, the Blower is switched on.
4. After the ILK circuit is closed and the purge rate proving blower RPM is achieved — prepurge time is started.
5. When the purge time is complete, the purge blower RPM is changed to the Ignition Rate.
6. As soon as the blower rpm is equal to the ignition rpm, the Trial for Ignition is started.
7. The ignition and the gas valve are switched on.
8. The ignition is turned off at the end of the direct burner ignition period.
9. The blower is kept at the ignition rate during the stabilization period.



## Sola control overview & sequence of operation *(cont.)*

10. At the end of the CH-heat request the burner is switched off and the blower stays on until post purge is complete.
11. A new CH-request is blocked for the forced off time set by the Anti Short Cycle parameter (adjustable, with default setting of 1 minute).
12. The pump stays on during the pump overrun time.
13. At the end of the pump overrun time the pump will be switched off.

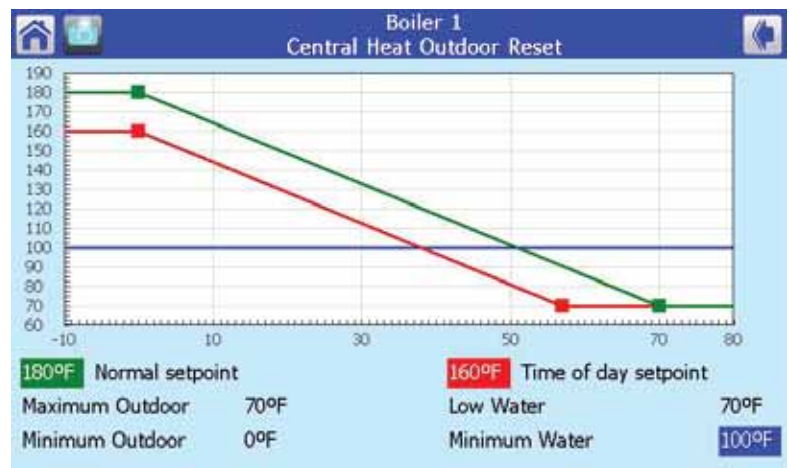
### Domestic Hot Water operating sequence

1. Heat request detected (DHW aquastat closes).
2. The DHW pump is switched on.
3. After a system Safe Start Check, the Blower is switched on.
4. After the ILK circuit is closed and the purge rate proving blower RPM is achieved — prepurge time is started.
5. When the purge time is complete, the purge blower RPM is changed to the Ignition Rate.
6. As soon as the blower rpm is equal to the ignition rpm, the Trial for Ignition is started.
7. The ignition and the gas valve are switched on.
8. The ignition is turned off at the end of the direct burner ignition period
9. The blower is kept at the ignition rate during the stabilization period.
10. At the end of the DHW-heat request the burner is switched off and the blower stays on until post purge is complete.
11. The pump stays on during the pump overrun time.
12. At the end of the pump overrun time the pump will be switched off.

### Outdoor reset operation


1. See Figure 59 for an example reset curve. Reach Configuration menus mentioned below via Home ➤ Boiler Icon ➤ Configuration. The parameters shown on the graph explained below.
2. **Normal setpoint**
  - a. This is the space heating temperature setting in CH-Central heat configuration ➤ Setpoint tab ➤ Setpoint.
3. **Low water**
  - a. This is from Outdoor Reset Configuration ➤ Low water temperature. This is the target temperature at Max outdoor.
4. **Minimum water**
  - a. This is the value in Outdoor Reset Configuration ➤ Minimum boiler water temperature. The sola will never use a target temperature less than this value.
5. **Maximum and minimum outdoor**
  - a. These are the values from Outdoor Reset Configuration ➤ Maximum outdoor temperature and Minimum outdoor temperature.
6. How operating target temperature is determined
  - a. At outdoor temperatures between Maximum and Minimum outdoor (sloped portion of the graph), the Sola control uses a space heating target temperature equal to the value on the curve.
  - b. Outside this range (flat line sections of the graph at upper and lower ends), the Sola control uses a fixed value (equal to the Normal setpoint temperature, Minimum water temperature, or Low water temperature).

**Figure 59** Typical outdoor reset curve (snapshot from: HOME PAGE ➤ ➤ Configuration ➤ Outdoor Reset Configuration ➤ Show Line)



# Sola control interface and menus

## Power-up & initialization

- When power is applied, the display loads operating software and performs self diagnostics. The **Home page** (Figure 60 or Figure 61) will appear when the device is properly powered and initialization is successful.
  - Select the **SETUP** button to adjust backlight and sound if desired.
- The **stand-by screen** (screen saver showing WEIL-McLAIN logo) appears if the display is left idle for a time and screen saver is enabled set in the Display Setup menu (SETUP ► DISPLAY SETUP ► SCREEN SAVER tab).
- A **camera icon**  on the left top corner is for screen snapshot use. Up to 16 snapshots can be stored in the display and can be copied to a USB memory stick. On any screen that displays the camera icon, press the camera to record the screen image.

## Sola page navigation

- The pages are arranged in a tree structure, as shown in Figure 63, page 61.

**Figure 60** Sola display Home page (Single boiler system —boiler in normal operation)



**Figure 61** Sola display Home page (Boiler #1 in multiple boiler system —boiler in normal operation)



**Figure 62** The Home page boiler icon will appear in one of four colors, indicating the boiler status —

**NOTICE**

**Boiler icon color:**


**PEWTER** — Normal operation

**RED** — Lockout condition


**YELLOW** — Holding mode (this is a normal condition, and indicates that the control is waiting for an event to complete)

**BLACK** — Communication error (disconnected or power off)

**NOTICE**

Pressing the **BOILER ICON**  opens the control's status page. Control adjustment and diagnostic pages are accessible from here. See Figure 63, page 61 for navigation details.

## Contractor log-in

- The installer/technician must log in to change control settings other than temperature and those settings available to the user. To log in, press the **PADLOCK**  button from any setup or configuration screen.
- Enter this code: **sf** (must be lower case)
- After 10 minutes of inactivity, the control will automatically lock again. Log in again using the same procedure as above.
- Then hit the enter key. The padlock should now display as open instead of locked. You must log in again if inactivity time lapses (padlock will show as closed).
- Hit the padlock again to re-lock the control.

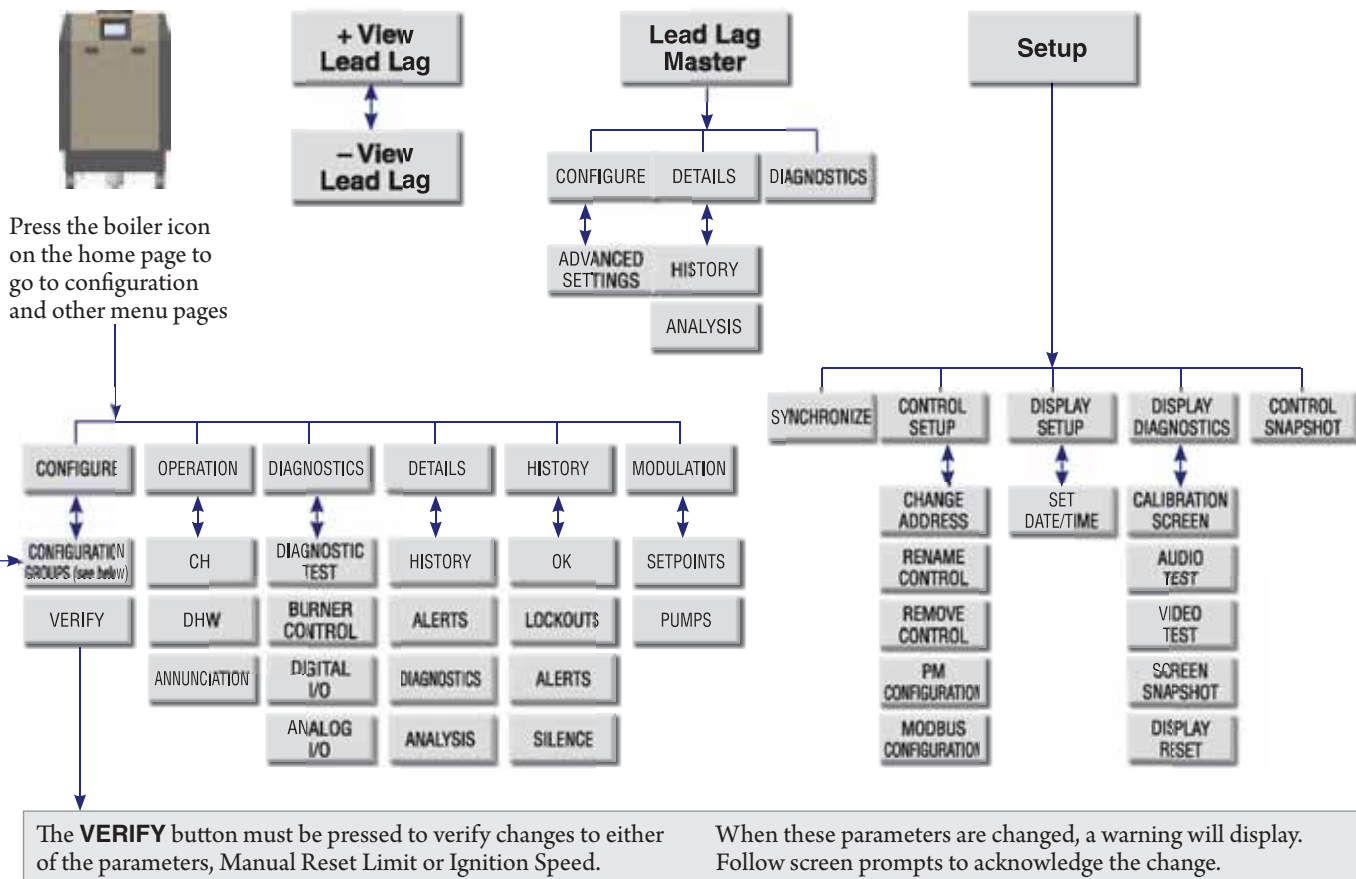
## Home page

- A screen similar to Figure 60 or Figure 61 appears after the display has completely powered up. The Boiler icon will appear in one of four colors, indicating the boiler status. See Figure 62.
- The Home page includes buttons for Lead Lag configuration when lead lag master or slave in the Sola control is enabled. The LEAD LAG MASTER button only appears on the master boiler's home page.
- Pressing the **SETUP** button on the Home page displays miscellaneous setup and diagnostic functions. It also contains the setup configuration for building management system applications.



# Sola control interface and menus *(continued)*

**Figure 63** Sola display page flow — top row below shows buttons available from the home page (must log in to change) Most pages have a Home button on the top-left corner of the screen and a Back button on the top-right corner of the screen. The Home button returns the user to the Home page and terminates any operation in progress. The Back button returns the user to the previous page.



**CONFIGURATION GROUPS** (Available from CONFIGURE page — Scroll down the display page to access desired group)  
 (See complete description of all Sola setup options in Figure 60, page 60)

Group name	Functions	Group name	Functions
System Identification & Access	Boiler name and installation data	Frost Protection Configuration	Enable/disable & set operating characteristics
CH – Central Heat Configuration	Enable/disable & demand switch, priority, setpoint and modulation settings	Annunciation Configuration	Set up annunciation source names
Outdoor Reset Configuration	Enable/disable & set operating temperatures	Burner Control Timings & Rates	Parameters cannot be changed
DHW – Domestic Hot Water Configuration	Enable/disable & set operation characteristics	Burner Control Ignition	Parameters cannot be changed
Warm Weather Shutdown Configuration	Enable/disable & set outdoor temperature	Burner Control Flame Failure	Parameters cannot be changed
Demand Priority Configuration	Set boiler's operating priorities	System Configuration	Set temperature units and operation timings
Modulation Configuration	Set modulation rates and operation characteristics	Sensor Configuration	Set up outdoor sensor, when used
Pump Configuration	Program pump operation of the 3 pump outputs	Lead Lag Slave Configuration	Enable/disable, set Modbus address and other
Statistics Configuration	Observe and reset operating statistics	Lead Lag Master Configuration	Enable/disable, set Modbus address and other
High Limits	Parameters cannot be changed		



# Sola control interface and menus *(continued)*

## Configuration

(HOME PAGE → → CONFIGURE)

1. Most parameter setup changes are done with one of the CONFIGURATION GROUPS shown in Figure 63, page 61.
2. See information beginning on page 68 for typical configuration setups.

## Alarm silencing

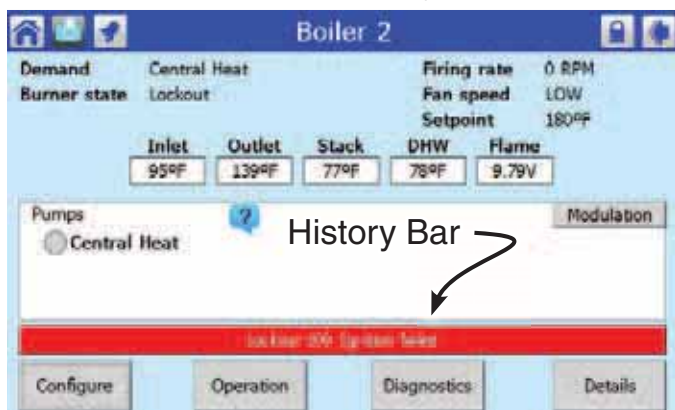
1. To silence an alarm, press the reset button on the top of the boiler or press the Silence button from the History screen (see Figure 66).

## Fault/Alarm Handling

(HOME PAGE → → HISTORY BAR)

1. Safety lockouts are indicated on all pages in the Title bar as an alarm bell symbol. At the status page, the History bar turns red (see Figure 64).

**Figure 64** Red history bar on Status page



**Figure 65** Red Boiler icon on Home page



2. In an alarm condition, the home page boiler icon will turn red (see Figure 65).

3. The lockout history can be displayed by accessing the History screens as described in the next section.

## History and Alert Log

(HOME PAGE → → DETAILS → HISTORY) or

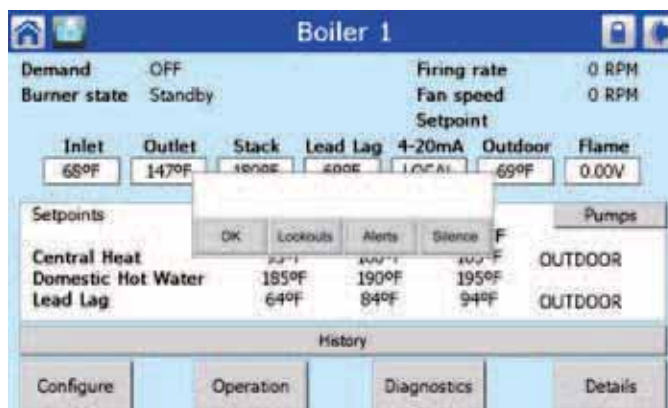
(HOME PAGE → → HISTORY BAR → LOCKOUTS or ALERTS)

**NOTICE**

The Sola control records the **date and time** of fault occurrences. To ensure accuracy of this information, the date and time must be set using the display setup menu as instructed on page 67.

1. The History bar on the Status page serves not only as a button, but also displays Sola Control lockouts, holds, and alerts as they occur. The example in Figure 63 shows the History bar readout for an Ignition failure, along with the lockout fault code.
2. Press the History bar to access lockout and alert history. This will activate a small dialog box in the middle of the screen as shown in Figure 66.
3. Selection options:
  - a. Press OK to return.
  - b. Press Lockouts to see the Lockout History screen (Figure 67).
  - c. Press Alerts to see the Alerts History screen (Figure 69).
  - d. Press Silence to silence the alarm.

**Figure 66** History screen (appears when History bar is pressed) — center dialog box will also show current fault, if any



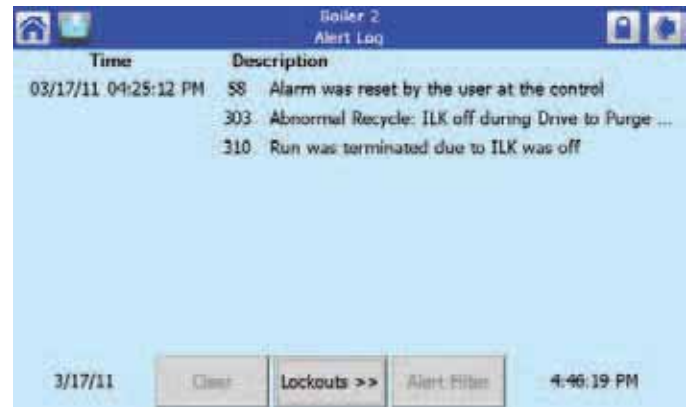


# Sola control interface and menus *(continued)*

**Figure 67** History screen, typical

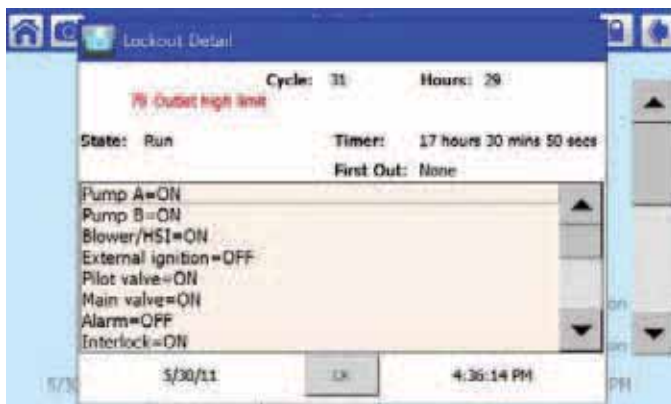


**Figure 69** Alert log example



4. History screen overview
  - a. The entire 15 fault code history is displayed in a scrollable list, with faults listed in reverse order of occurrence.
  - b. Summary information is displayed for each fault entry, including the burner cycle count, fault code, and fault number with description. See Figure 67.
  - c. Detailed information for a specific fault entry that also includes burner control sequence state, burner run-time hours, annunciation status, etc., is viewed by selecting (touching the History line) the lockout entry in the list.
  - d. Press the CLEAR LOCKOUT button to acknowledge and clear (reset) the Sola control. (This can also be done by pressing the reset button on top of the boiler.)
5. History exploded view — Press the screen on one of the items in the history log to show details of this fault occurrence, as in Figure 68.
6. Alert screen overview
  - a. Press the Alerts button from the History screen to access the alerts log.
  - b. Alerts are records of non-lockout events, such as holds. See Figure 69 for examples.
  - c. Press the screen on one of the alert items to see an exploded (detailed) record of the event.

**Figure 68** History example (exploded view)



## Diagnostics Button

(HOME PAGE → → DIAGNOSTICS)

1. The **DIAGNOSTICS** button displays analog and digital I/O status of the Sola Control (Figure 70). The diagnostic status is displayed and this screen and is updated once per second.

- NOTICE** The term, I/O, means inputs and outputs, such as limits, thermostats, relay contacts, etc.
2. The digital I/O Status data is displayed as LEDs that are either on (green) or off (gray).
  3. Not all digital I/O can be displayed at the same time on the page, so a horizontal scroll bar is used to move the view left and right to show all digital I/O data.

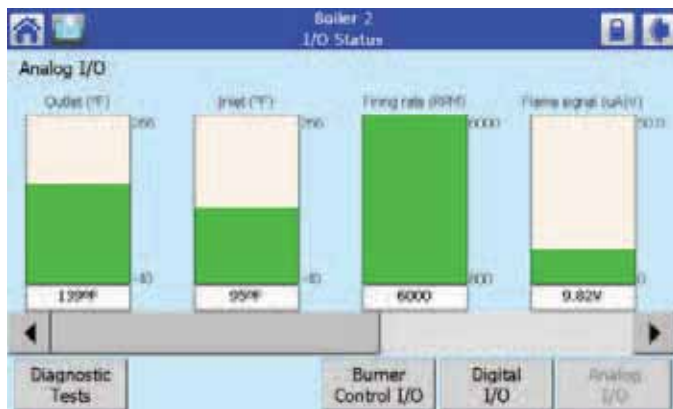
**Figure 70** Digital I/O Status page  
(HOME PAGE → → DIAGNOSTICS)



4. The control analog I/O can also be viewed on the Display. A snapshot of the diagnostic status is displayed and updated as it changes in the control. The analog I/O data is displayed as bar charts with I/O level represented in the I/O range (see Figure 71).
5. Analog I/O that is not enabled for the installation displays a blank I/O level. Not all analog I/O can be displayed at the same time on the page, so a horizontal scroll bar is used to move the view left and right to show all analog I/O status.

## Sola control interface and menus *(continued)*

**Figure 71** Analog I/O Status page

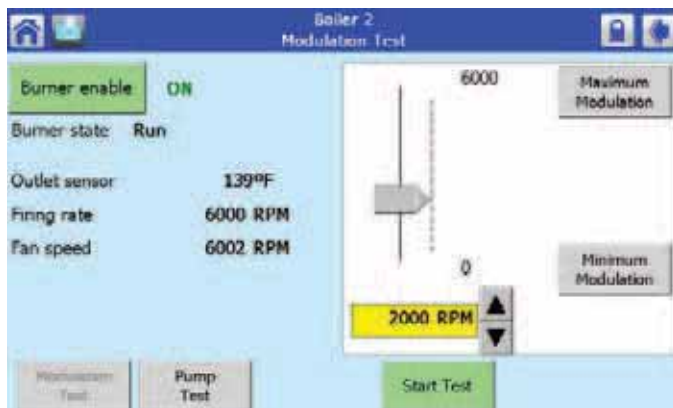


### Diagnostics Tests

(HOME PAGE → → DIAGNOSTICS → DIAGNOSTICS TESTS)

- Pressing the DIAGNOSTICS TESTS button launches the diagnostic tests (Figure 72).
- This screen enables the user to perform the following tests:
  - Modulation Test: enables the user to verify that the burner is firing at the correct rate. (See Figure 72.)
  - Pump Test: enables the user to verify that the correct pump is on or off. The Start Test button will test all pumps; pressing an individual pump tests that pump only. (See Figure 73, page 64.)
  - Burner Switch: this button turns the burner on or off.
  - Start Test: runs the test for 5 minutes.

**Figure 72** Modulation test



**NOTICE**

Use the modulation test screen to manually control the boiler firing rate during startup combustion verification.

**Figure 73** Pump test.

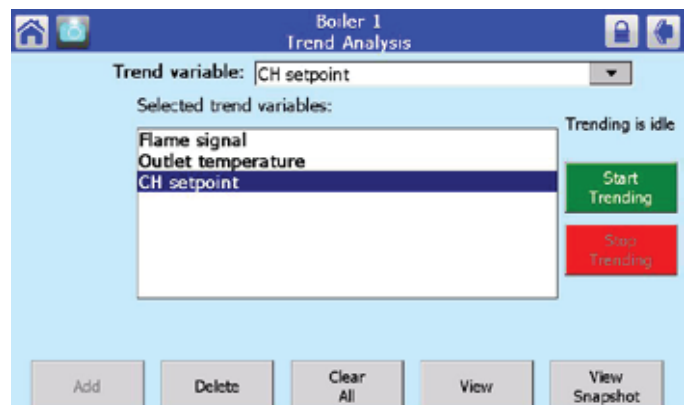


### Trend Analysis

(HOME PAGE → → DETAILS → ANALYSIS)

- Use the Sola control's trend analysis functions to see graphical displays of operating data vs time (see Figure 75).
- To start a trend analysis:
  - Press the ANALYSIS button on the Details screen. Select the operating data to be monitored.
  - The Trend Analysis screen will appear (Figure 75).
  - Up to 10 variables can be trended at the same time.
  - To add an operating variable to the list, use the Trend Variable drop-down menu at the top. Select an item. Then press the ADD button (bottom left).
  - To remove items from the list, press DELETE for a single highlighted item or CLEAR ALL to remove all items.
  - Only two different measurement units can be trended (such as degrees and RPM's, for example). The control won't accept another item if it requires a different unit.
  - When ready to view the graph, press the START TRENDING button (upper right). To stop a trend run, press the STOP TRENDING button (right center).
  - To see the graph, press the VIEW button to go to the graph screen.
  - To see a saved trend analysis, press the VIEW SNAPSHOT button. From the next screen, select the saved analysis desired.

**Figure 74** Trend analysis menu



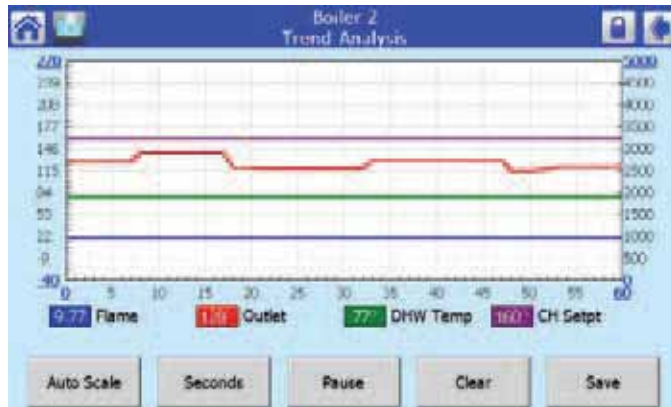




## Sola control interface and menus *(continued)*

3. Trend analysis graph page
  - a. This page shows a graph that updates over time.
  - b. The graphs shows the values of operating variables selected on the Trend Analysis menu page.
  - c. Each status variable displayed in the trend analysis is represented by a different colored line.

**Figure 75** Trend analysis page, typical



4. The X-axis — time range
  - a. Trend data can be viewed in intervals of Seconds (0–60 sec), Minutes (0–60 min.) Hours (0–24 hr.) or Days (0–30 days).
  - b. The button to the right of AUTO SCALE shows the current interval. Press this button to toggle between seconds, minutes, hours or days.

**NOTICE** Full graphs require that the display has been monitoring the Sola control for the complete time range of the X-axis. Otherwise, the values only display up to the amount of time elapsed since pressing the Start Trending button.

- c. The display will update once per second.
  - d. When the readout reaches the right side of the graph, data will be dropped from the left, with the current value always at the right of the lines.
5. The Y-axis, left and right scales
  - a. Only two measurement units are allowed when selecting variables.
  - b. The left scale will always show degrees if any of the variables uses degrees. Otherwise, the left side will be the unit for the first variable in the list.
  - c. The right scale will show the second measurement unit.
  - d. The scale range is set by the variable with the largest range.

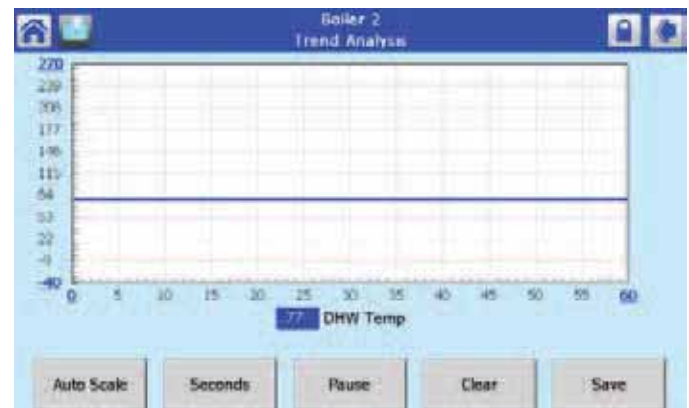
**NOTICE** Pressing the PAUSE button will pause trend data updates of the graph. The graph “freezes” the view when stopped. However, trend data continues regardless whether the graph update is stopped or not. Restarting the updates causes the graph to be refreshed with the latest data samples.

6. Press the CLEAR button to clear the trend sample data. All trend data is cleared including variables that are not included in the graph. The user is asked to confirm this action before proceeding.

**NOTICE** Press the SAVE button to store a snapshot of the screen. While this snapshot is saved, trend data sampling is temporarily halted. Gaps or static level values occur in the trend data as a result.

7. Operation Trend analysis graphs can be viewed for CH, DHW, and Lead Lag demands. These are available as selections on the Trend Analysis page, and automatically select related variables to be monitored. See a typical example graph in Figure 76.
  - a. The default sample rate is 15 sec periods (a tick mark on the X axis for every 15 second period, with minutes displayed every 4 tick marks).

**Figure 76** Operation Trend analysis graph



8. Trend analysis graph for heat exchanger operation can also be selected on the Trend Analysis (see a typical example in Figure 77).

**Figure 77** Vessel analysis graph



**NOTICE** Automatic sampling of trend data takes place when the trend analysis report is displayed. No user intervention is necessary to invoke sampling.

Sample data is collected and stored in the display. Any reset causes all sampling to start over with no data.

## Sola control interface and menus *(continued)*

### Trend Analysis Snapshot

1. The trend analysis snapshot file is stored in Comma Separated Value (CSV) format in the display so it can be imported into a spreadsheet program such as Microsoft Excel. The trend analysis snapshot file can be viewed in graph form on the display. It can also be copied to a USB device.
2. To save the trend analysis page, the SAVE button must be pressed on the trend analysis page. From there, the trend file can be given a name. To save to a USB drive, press VIEW SNAPSHOT, select the snapshot, then press COPY TO USB (see Figure 74).
3. At any time, pressing the “camera” button on the top left corner in the menu bar will capture a screenshot, which can be transferred to a USB memory stick. Go to Home page--> Setup--> Display Diagnostics--> Screenshot--> press the snapshot file on the list --> Copy to USB.

### System Configuration

(HOME PAGE → SETUP)

1. Pressing the DISPLAY REFRESH button starts a search procedure.
  - a. A new boiler control is identified by “Unknown” status next to its name in the boiler system list (see Figure 78).
  - b. “Unknown” indicates that configuration data has not been retrieved from the control yet.
  - c. Once the control is located it must be synchronized with the display before it can be displayed. New controls are not displayed on the Home page until this synchronization is performed.

**Figure 78** System refresh and synchronize screen



### System Synchronization

(HOME PAGE → SETUP → SYNCHRONIZE)

1. Manually synchronize configuration data from the connected controls at any time.
2. A new control is visible when configuration and status data is gathered from it.
  - a. This collection procedure takes a few minutes. The control is marked as “Unknown” when no configuration information exists. Normally, control configuration data collection only needs to be performed when the control is initially installed.

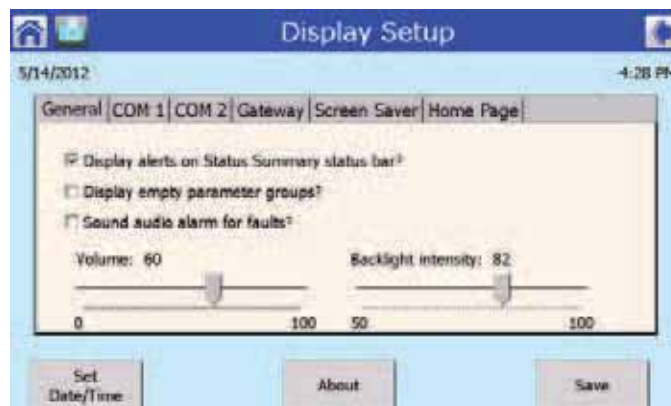
3. Press the SYNCHRONIZE button to begin synchronization with the control.

### Display setup

(HOME PAGE → SETUP → DISPLAY SETUP)

1. The SETUP page allows the user to configure display settings. Press the SETUP button on the Home page to bring up the Setup page (See Figure 78).
2. Press the DISPLAY SETUP button to display options that can be set by the user.
3. The GENERAL tab (Figure 79) contains the following settings:
  - a. Display alerts on Status Summary Bar? This determines whether non-safety alerts will be shown on the summary bar of the Status page.
  - b. Display empty parameter groups? This cleans up the home page by hiding unused parameter groups.
  - c. Sound audio alarm for faults? This uses the display speaker to sound an alarm on shutdown for Sola faults.

**Figure 79** Display setup page - General setup tab



4. The COM1 and COM2 tabs contain the following settings:
  - a. Enable COM1/COM2 port — DO NOT change.
  - b. Modbus address range 1-N: Sets the range of Modbus addresses to search for connected devices (range is 1 to 250).
  - c. Modbus baud rate — DO NOT change.

**NOTICE**

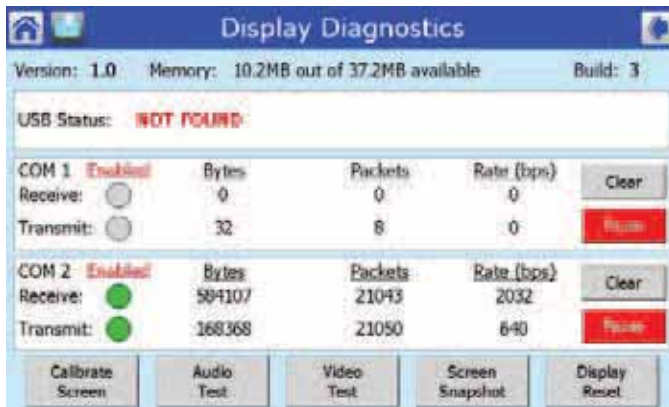
**DO NOT CHANGE COM SETTINGS OR BAUD RATES.** Changing these settings can cause the control from operating.

5. Pressing the DISPLAY DIAGNOSTICS button (HOME PAGE → SETUP → DISPLAY DIAGNOSTICS) permits display hardware diagnostics. Normally, these diagnostics are applicable only for factory testing purposes, but conditions may arise that warrant this testing. The CONTROL SNAPSHOT button allows the user to dump the current status and/or configuration settings of any Sola control into a text document. The text document can be viewed on the display, saved for later viewing, and can be written to a USB stick for viewing on a PC or file transfer.
6. Press the GATEWAY to verify that ENABLE MODBUS GATEWAY? is NOT checked unless the boiler is connected to a BMS. If a BMS is used, see the SlimFit Modbus manual for details.
7. Press the Screen Saver tab to select the screen saver and to set screen saver idle wait time.



# Sola control interface and menus *(continued)*

**Figure 80** Display diagnostics



- Each test is invoked by pressing the TEST button next to the diagnostic.

## To set Date and Time

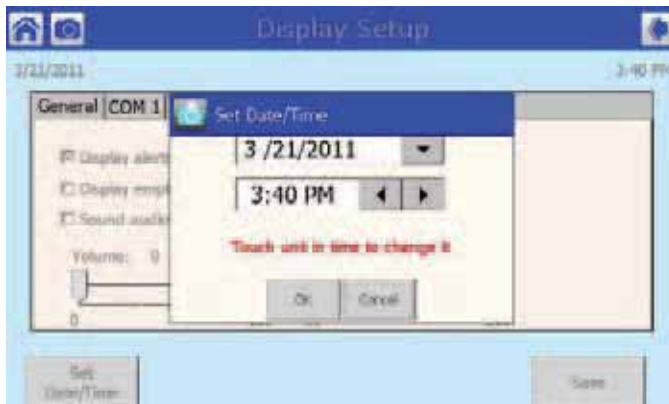
(HOME PAGE → SETUP → DISPLAY SETUP → DATE/TIME)

- Set the time/date by selecting the SET DATE/TIME button on the Display Setup page (see Figure 81).
  - Edit the date and time and press the OK button to set the new settings.
  - Press the CANCEL button to exit without changing the time or date.

**NOTICE** Set the date and time to ensure accuracy of time stamping for faults and alerts stored by the Sola control.

The time and date need to be reset should power be interrupted to the display. (See information about the display battery in this section.)

**Figure 81** Display Date and Time



## Display Reset

(HOME PAGE → SETUP → DISPLAY DIAGNOSTICS → DISPLAY RESET)

- The user can reset the display and force a power-up by pressing the Display Reset button. A pop-up dialog box confirming the reset request displays (Figure 82) before the reset proceeds.

**Figure 82** Processor Reset



- When the Display is reset, the display will reboot and automatically seek out the Modbus device connected to it. When the search is complete, the display will return to the home page.

## Display battery

- The display is fitted with a CR2032 coin battery, located on the rear of the display.
- This battery will maintain display setup data during brief power outages.

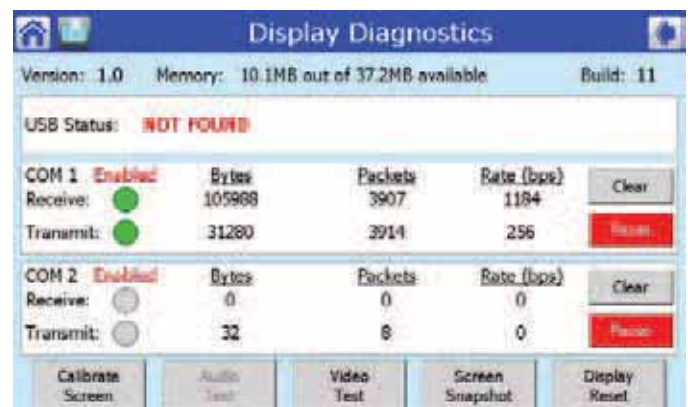
**NOTICE** **Battery replacement** — When the display battery loses charge, it will no longer ensure data is maintained. If the display time changes unexpectedly, the battery probably needs to be replaced.

## Version

(HOME PAGE → SETUP → DISPLAY DIAGNOSTICS)

- Pressing the DISPLAY DIAGNOSTICS button in the Setup page will display the software version, build and memory information (see Figure 83).

**Figure 83** Code version





# Sola control express setup — single boiler

## Sola control single boiler setup

1. The Sola control is adapted to meet the system operation needs using adjustable parameters. The complete list of these parameters is in “Sola control parameter table” beginning on page 72.
2. The factory default settings for the Sola parameters meet the needs of most systems, requiring only a few adjustments. These express setup instructions provide guidelines for checking and/or changing only those parameters needed for general operation.
3. Also covered in express setup are instructions for setting up the Sola control for analog input (remote setpoint or modulation control).
4. Enter **installation information** in HOME PAGE → → CONFIGURE → SYSTEM IDENTIFICATION & ACCESS.
5. Go to HOME PAGE → SETUP → DISPLAY SETUP → SET DATE/TIME to set **date and time**.
6. **Temperature settings** — review Figure 84 to see if changes are needed for job requirements. See page 59 for Outdoor reset temperature value explanations.
7. **Other factory presets** — review Figure 84 to see if other common parameters need to be adjusted for the application.
8. **Power wiring** — see Field Wiring instructions beginning on page 51.
9. **Outdoor sensor** — locate on an exterior wall and shield to prevent solar gain. Wire to OUTDOOR/HEADER terminals on terminal strip C. Thermostat wire is acceptable.
10. **System sensor** — **no system sensor is used**. The Sola control will regulate boiler outlet water temperature.
11. **Thermostat** — Space heating thermostat, end switch or call for heat contact wires to the T-STAT terminals on terminal strip C.
12. **DHW aquastat** — DHW tank aquastat wires to DHW terminals on terminal strip C.

**Figure 84** Factory default settings (most common parameters— see complete list in “Sola control parameter table” beginning on page 72)

Temperatures — CH	Value	Menu page
Setpoint	180°F	HOME PAGE →  → CONFIGURE → <b>CH-Central Heat Configuration</b> <small>(Use the upper scroll arrows to scroll left or right until the heading says Setpoint)</small>
Max. outdoor temp.	80°F	HOME PAGE →  → CONFIGURE → <b>Outdoor Reset Configuration</b>
Min. outdoor temp.	0°F	
Low water temp.	120°F	
Min. boiler water temp.	0°F	

Temperatures — DHW	Value	Menu page
Setpoint	190°F	HOME PAGE →  → CONFIGURE → <b>DHW-Domestic Hot Water Configuration</b>

Priority — DHW	Value	Menu page
DHW priority vs CH	DHW>CH	HOME PAGE →  → CONFIGURE → <b>DHW-Domestic Hot Water Configuration</b>
DHW priority override time	60 min	

Pumps	Value	Menu page
Boiler pump	Pump A	HOME PAGE →  → CONFIGURE → <b>Pump Configuration</b> <small>(Use the upper scroll arrows to scroll left or right until the heading shows Boiler pump, System pump, or DHW pump)</small>
System pump	Pump B	
DHW pump	Pump C	

Warm Weather SD	Value	Menu page
Warm weather shutdown enable	Disabled	HOME PAGE →  → CONFIGURE → <b>Warm Weather Shutdown Configuration</b>
Warm weather shutdown setpoint	60°F	

Frost protection	Value	Menu page
CH frost protection enable	Disabled	HOME PAGE →  → CONFIGURE → <b>Frost Protection Configuration</b>
DHW frost protection enable	Disabled	
Outdoor frost protection setpoint	32°F	
CH frost protection overrun time	1 min	
DHW frost protection overrun time	1 min	

**⚠ WARNING** The system must provide for pump flow during overrun times. Failure to comply could result in severe personal injury, death or substantial property damage.



# Sola control express setup — single boiler *(continued)*

## Zoning with zone valves — Primary/secondary piping

[Apply for Figure 16, page 17 or Figure 17, page 18]

1. No changes are needed unless the factory default values in Figure 84 need to be adjusted.

## Zoning with pumps — Primary/secondary piping

[Apply for Figure 18, page 19]

1. Pumps
  - a. Connect the Boiler pump to Pump A terminals on terminal strip D.
  - b. Connect the DHW pump to Pump C terminals on terminal strip D.
  - c. The other pump output (Pump B) is not used for pump control.

## Radiant heating applications

[Apply for Figure 19, page 20]

1. No changes are needed unless the factory default values in Figure 84 need to be adjusted.

**⚠ WARNING** See **WARNING** on page 58 regarding protection of systems from excessive temperature. Set the Sola temperatures appropriately for the system and provide limit controls if necessary.

## Analog input option — setpoint

1. Go to HOME PAGE → → CONFIGURE → CH-CENTRAL HEAT CONFIGURATION
  - a. Menu title should say Setpoint. If not, use the upper right or left arrow to toggle to the Setpoint page.
  - b. Press CH Setpoint source.
  - c. Select S2 (J8-6) 4–20mA.
  - d. Press 4mA water temperature — select water temperature at minimum signal.
  - e. Press 20mA water temperature — select water temperature at maximum signal.

## Analog input option — modulation

1. Go to HOME PAGE → → CONFIGURE → CH-CENTRAL HEAT CONFIGURATION
  - a. Use upper right or left arrow to toggle to the Modulation page.
  - b. Press CH modulation rate source.
  - c. Select S2 (J8-6) 4–20mA and burner on/off.
2. Connect a thermostat or call for heat contact across the T-STAT terminals on terminal strip C.
  - a. Modulation operates based on the 4–20mA input signal.
  - b. The boiler is turned on/off by the T-STAT input.

## High altitude installations *(above 5500 feet)*

**⚠ WARNING** For altitudes above 5,500 feet, **the Sola control must be set to the proper Lightoff rate.** In addition, the minimum and maximum firing rates must be set as specified for high altitude. Follow the procedures given in “Set/verify blower speed settings” on page 90. Failure to properly set the firing rates could result in unreliable operation and loss of heating.



# Sola control express setup — multiple boilers

## Multiple boiler system requirements

- Up to 8 SlimFit boilers on a system.
- Boilers must be connected from boiler to boiler with twisted 3-wire cable on LEAD/LAG CONNECTION terminals on terminal strip F. Cable length must not exceed 600 feet (may require terminating resistors on long runs).
- **System sensor** must be installed on system supply header and connected to master boiler.
- **Outdoor sensor** (recommended) must be connected to one of the **slave** boilers on the OUTDOOR/HEADER terminals on terminal strip C.
- **Power wiring** — see Field Wiring instructions beginning on page 51.

## Setup required on EVERY boiler

1. Go to HOME PAGE → → CONFIGURE → SYSTEM IDENTIFICATION & ACCESS.
  - a. Select Installation information and input description.
  - b. Scroll down to **MB2** Modbus address (**NOT MB1**). Enter “1” on the master boiler control. Enter a number from 2 to 8 on each of the slave boilers. Each boiler must have a different number.

**⚠ WARNING** DO NOT change the setting for **MB1** from the factory default setting of (1).

2. Go to HOME PAGE → SETUP → DISPLAY SETUP → SET DATE/TIME to set **date and time**.
3. Go to HOME PAGE → → CONFIGURE → PUMP CONFIGURATION.
  - a. Use the upper arrows to toggle to the Boiler pump screen.
  - b. Press the **ADVANCED** button (bottom right).
  - c. Remove the check mark next to Central Heat: Service active.
4. The Sola control is adapted to meet the system operation needs using adjustable parameters. The complete list of these parameters is in “Sola control parameter table” beginning on page 72.
5. The factory default settings for the Sola parameters meet the needs of most systems, requiring only a few adjustments. These express setup instructions provide guidelines for checking and/or changing only those parameters needed for general operation.

## Analog input options

1. Make the same changes as instructed for a single boiler on page 69, but use the Central Heat page of the Lead Lag Master Configuration menu Advanced Settings.

## High altitude installations *(above 5500 feet)*

**⚠ WARNING** For altitudes above 5,500 feet, **the Sola control must be set to the proper Lightoff rate**. In addition, the minimum and maximum firing rates must be set as specified for high altitude. Follow the procedures given in “Set/verify blower speed settings” on page 90. Failure to properly set the firing rates could result in unreliable operation and loss of heating.

**Figure 85** Factory default settings for lead lag (most common parameters — see complete list in “Sola control parameter table” beginning on page 72)

Temperatures — CH	Value	Menu page
Setpoint	170°F	HOME PAGE →  → CONFIGURE → <b>Lead Lag Master Configuration</b>
Max. outdoor temp.	80°F	HOME PAGE →  → CONFIGURE → LEAD LAG MASTER CONFIGURATION → ADVANCED SETTINGS → <b>Outdoor Reset</b>
Min. outdoor temp.	0°F	
Low water temp.	120°F	
Min. blr. water temp.	0°F	

Temperatures & Priority — DHW	Value	Menu page
Setpoint	190°F	HOME PAGE →  → CONFIGURE → LEAD LAG MASTER CONFIGURATION → ADVANCED SETTINGS → <b>Domestic Hot Water</b>
DHW has priority over CH? <i>(applies only if DHW is supplied by the entire lead lag group)</i>	DHW> CH	
DHW priority override time	60 min	HOME PAGE →  → CONFIGURE → <b>Outdoor Reset Configuration</b>
DHW has priority over LL? <i>(applies to any boiler with direct-connected DHW)</i>	DHW> LL	

Pumps	Value	Menu page
Boiler pump	Pump A	HOME PAGE →  → CONFIGURE → <b>Pump Configuration</b> <i>(Use the upper scroll arrows to scroll left or right until the heading shows Boiler pump, System pump, or DHW pump)</i>
System pump	Pump B	
DHW pump	Pump C	

Warm Weather SD	Value	Menu page
Warm weather shutdown enable	Disabled	HOME PAGE →  → CONFIGURE → LEAD LAG MASTER CONFIGURATION → ADVANCED SETTINGS → <b>Warm Weather Shutdown</b>
Warm weather shutdown setpoint	60°F	

Frost protection	Value	Menu page
Enable	Disabled	HOME PAGE →  → CONFIGURE → LEAD LAG MASTER CONFIGURATION → ADVANCED SETTINGS → <b>Frost Protection</b>
Outdoor setpoint	32°F	

**⚠ WARNING** The system must provide for pump flow during overrun times. Failure to comply could result in severe personal injury, death or substantial property damage.



## Sola control express setup — multiple boilers *(continued)*

### MASTER boiler setup

- System sensor** — attach the system sensor to the system supply piping. Wire from the sensor to the OUTDOOR/HEADER terminals on terminal strip C.
- Thermostat** — Space heating thermostat, end switch or call for heat contact wires to the T-STAT terminals on terminal strip C of the master boiler.
- System pump** —
  - Connect the System pump to the master boiler Pump B terminals on terminal strip D.
- Boiler pump** —
  - Connect the master boiler's Boiler pump to the master boiler's Pump A terminals on terminal strip D.
- DHW options** —
  - DHW as a system zone or supplied by the entire multiple boiler group — DHW tank aquastat wires to DHW terminals on terminal strip C of the master boiler. Connect the DHW pump to the master boiler Pump C terminals on terminal strip D. (Also, set DHW demand switch to "DHW (S6) sensor shorted" on the Lead Lag Master Configuration ➤ Domestic Hot Water page.)
  - DHW connected to one of the slave boilers — DHW tank aquastat wires to DHW terminals on terminal strip C of the slave boiler. Connect the DHW pump to the slave boiler Pump C terminals on terminal strip D.
- Enable master boiler (as master)**
  - The master boiler must be set up both as master and as a slave boiler. This allows it to operate when the Sola control rotates lead/lag sequencing.
  - Go to HOME PAGE ➤ ➤ CONFIGURE ➤ LEAD LAG MASTER CONFIGURATION ➤ Master Enable.
  - Select "Enabled."
- Master — Setpoint temperature setting**
  - From the Lead Lag Master Configuration main screen, press the ADVANCED SETTINGS button.
  - Use the scroll arrow at upper right or left to scroll to the Central Heat menu.
  - Select Setpoint and enter the required setpoint temperature.
- Master — Outdoor reset settings**
  - From the Lead Lag Master Configuration Central Heat menu, use the scroll arrow at upper right or left to scroll to the Outdoor Reset menu.
  - If the first parameter, Enable, does not show Enabled, select it and change to Enabled.
  - The Setpoint selected in the previous step is the top line of the reset curve.
  - Set the remaining outdoor reset temperatures as required for the installation. See page 59 for Outdoor reset temperature value explanations.
  - Go to HOME PAGE ➤ ➤ CONFIGURE ➤ SENSOR CONFIGURATION ➤ Outdoor temperature source. Change the value to "UNCONFIGURED."
- Enable master boiler (as slave)**
  - From the Lead/Lag Master screens, press the Return button on the upper right of the screen to return to the Configure list.
  - Select LEAD LAG SLAVE CONFIGURATION.
  - From the Lead Lag Configuration main page, select the Enable line.
  - Select "Enable slave for built-in Lead Lag master."
- Other factory presets** — review Figure 85 to see if other lead lag common parameters need to be adjusted for the application. See "Sola control parameter table" beginning on page 72 for the complete list of parameters.

### SLAVE boiler setup

- Enable slave boiler**
  - Go to HOME PAGE ➤ ➤ CONFIGURE ➤ LEAD LAG SLAVE CONFIGURATION ➤ Enable.
  - Select "Enable slave for built-in Lead/Lag master"
- Outdoor sensor** — locate on an exterior wall and shield to prevent solar gain. Wire to OUTDOOR/HEADER terminals on terminal strip C to any one of the **SLAVE** boilers. Thermostat wire is acceptable. The Sola control will recognize this as the outdoor sensor (provided the slave boiler's factory default setting for Outdoor temperature source under SENSOR CONFIGURATION has NOT been changed — should show "S5 (J8-11) sensor").
- Boiler pump** —
  - Connect the Boiler pump of each slave boiler to the slave boiler's Pump A terminals on terminal strip D.
- DHW aquastat and DHW pump**—
  - DHW connected to one of the slave boilers — DHW tank aquastat wires to DHW terminals on terminal strip C of the slave boiler. Connect the DHW pump to the slave boiler Pump C terminals on terminal strip D.
  - See Figure 84, page 68 for default DHW settings.

### Multiple boilers — Space heating

*[Apply for Figure 21, page 23 or Figure 22, page 24]*

- Setup master and slave boilers as instructed in this section if using factory default pump assignments.

### Multiple boilers — Space heating with DHW as a zone

*[Apply for Figure 21, page 23 or Figure 22, page 24]*

- Setup master and slave boilers as instructed in this section.
- The DHW aquastat and DHW pump connect to the master boiler.
- Setup based on the instructions related to DHW supplied by the complete lead lag group.

### Multiple boilers — Space heating with DHW connected to a boiler

*[Apply for Figure 21, page 23 or Figure 22, page 24]*

- Setup master and slave boilers as instructed in this section.
- The DHW aquastat and pump connect to the boiler with the DHW piped to it.
- Setup based on the Slave boiler with DHW instructions in this section.

# Sola control parameter table

HOME PAGE →  → CONFIGURATION

**Figure 86** Sola CONFIGURATION VALUES — setup options — White text on black titles are configuration groups — see Figure 63, page 61 for location of configuration group in menus (**Enter changed values in the last column**)

Menu/Item	Units	Low Value	High Value	Default	Description	Changed to
<b>System Identification &amp; Access</b>						
Burner name	20 chars				This parameter allows each Sola control to have a unique name.	
Installation data	20 chars				The installer may edit this parameter to provide installation information.	
<b>CH – Central Heat Configuration</b>						
<b>Central Heat Page</b> (Use scroll arrows to toggle between Central Heat, Setpoint and Modulation pages)						
CH enable		Enable	Disable	Enable	This parameter determines whether the CH loop is enabled or disabled. When disabled heat demand caused by the input assigned to the CH loop is ignored. It may be disabled to turn it off temporarily, or because the application does not use this feature.	
CH demand switch		Sensor or STAT Terminal		STAT Terminal	This parameter specifies the source of CH loop heat demand: Sensor means use modulation sensor only STAT terminal means use STAT terminal input	
CH has priority over LL		Yes or No		No	This controls whether a local Central Heat demand has priority over the demand requested by the lead lag master, when this boiler is enabled as a slave.	
<b>Setpoint Page</b> (Use scroll arrows to toggle between Central Heat, Setpoint and Modulation pages)						
CH setpoint source		Local or S2(4–20mA)		Local	Determines the source of the setpoint for Central Heat: Local — use the setpoint determined by the Sola control S2 (4–20mA) — use remote analog input (4–20mA)	
CH setpoint	°F or °C	70°F (21°C)	190°F (88°C)	180°F (82°C)	This Setpoint is used when the time-of-day input is off. If the ODR function is active, this Setpoint provides one coordinate for the outdoor reset curve, as described for the CH Outdoor Reset parameter.	
CH TOD setpoint	°F or °C	70°F (21°C)	190°F (88°C)	160°F (71°C)	This Setpoint is used when the time-of-day input is on. If the ODR function is active, this Setpoint provides one coordinate for the shifted (because TOD is on) outdoor reset curve, as described for the CH Outdoor Reset parameter.	
CH off hysteresis	°F or °C	2°F (1°C)	8°F (6°C)	5°F (3°C)	The off hysteresis is added to the CH setpoint to determine the temperature at which burner demand turns off.	
CH on hysteresis	°F or °C	2°F (1°C)	10°F (6°C)	5°F (3°C)	The on hysteresis is subtracted from the CH Setpoint to determine the temperature at which burner demand turns on.	
CH 4 mA water temperature		60°F (16°C)	190°F (88°C)	70°F (21°C)	Analog input, Setpoint operation — Sets the water temperature setting at an analog input of 4mA.	
CH 20 mA water temperature		60°F (16°C)	190°F (88°C)	180°F (82°C)	Analog input, Setpoint operation — Sets the water temperature setting at an analog input of 20mA.	
<b>Modulation Page</b> (Use scroll arrows to toggle between Central Heat, Setpoint and Modulation pages)						
CH modulation sensor		Outlet sensor or S5 sensor		Outlet sensor	This selects the sensor used for modulation and burner demand for Central Heat. Outlet sensor — uses boiler outlet temperature sensor S5 sensor — uses system temperature sensor (HEADER SENSOR) connected to terminal strip C — can be connected to any boiler in a lead lag system	
CH modulation rate source		Local or S2 (4–20mA)		Local	This selects the source of modulation rate information for the central heat. Local — uses rate determined by Sola control S2 — uses modulation rate based on 4–20mA input value; modulation sensor turns boiler on/off	





# Sola control parameter table *(continued)*

HOME PAGE → → CONFIGURATION

**Figure 86** (continued) Sola CONFIGURATION VALUES — setup options — White text on black titles are configuration groups — see Figure 63, page 61 for location of configuration group in menus (**Enter changed values in the last column**)

Menu/Item	Units	Low Value	High Value	Default	Description	Changed to
<b>Outdoor Reset Configuration</b>						
Enable		Enable or Disable		Enabled	If outdoor reset is enabled, then the current outdoor temperature is used to determine the Setpoint by interpolation using CH Setpoint (or CH Time-Of-Day Setpoint if TOD is on), the low water temperature, and the min and max outdoor temperatures.	
Maximum outdoor temperature	°F or °C	50°F (10°C)	100°F (38°C)	80°F (27°C)	This parameter determines the maximum outdoor temperature for the CH outdoor reset graph. At or above the maximum outdoor temperature, the water temperature setpoint will be at the low water temperature.	
Minimum outdoor temperature	°F or °C	-40°F (-40°C)	100°F (38°C)	0°F (-18°C)	This parameter determines the X coordinate of one point on the CH outdoor reset graph. At this outdoor temperature the setpoint will be the CH setpoint (or the CH TOD setpoint, if TOD is on).	
Low water temperature	°F or °C	60°F (16°C)	190°F (88°C)	120°F (49°C)	This parameter provides the CH outdoor reset setpoint when the outdoor temperature is at or above the maximum specified by the Max outdoor temperature.	
Minimum boiler water temperature	°F or °C	60°F (16°C)	190°F (88°C)	0°F (-18°C)	The Sola control will always use a setpoint at least as warm as this setting, even when the reset curve would call for a lower temperature.	
Outdoor boost time	hr mm ss	0m 0s	60m 0s	0m 0s	When CH outdoor reset is active and demand has not been met for a period of time, then the setpoint is boosted, and when demand is met, it steps back toward normal. This parameter provides the time interval for each step, both up and down.	
Outdoor boost maximum off point	°F or °C	70°F (21°C)	190°F (88°C)	Unconfigured	This limits the maximum setpoint temperature, preventing setpoint from exceeding this value when setpoint is increased due to Boost.	
SHOW LINE					Press this button to see a graph of the reset curve.	
<b>Domestic Hot Water Configuration</b>						
DHW enable		Enable or Disable		Disabled	This parameter determines whether the DHW loop is enabled or disabled. When disabled the demand caused by the DHW sensor is ignored. It may be disabled to turn it off temporarily or because the application does not use this feature.	
Priority source		See description		DHW Heat Demand	DHW Heat demand or Disabled (disables DHW priority)	
Priority method		See description		Drop after priority time	Boost DHW during priority time Drop after priority time	
Setpoint	°F or °C	120°F (49°C)	190°F (88°C)	190°F (88°C)	This Setpoint is used for DHW whenever the time-of-day switch is off or not connected (unused).	
Time of day setpoint	°F or °C	120°F (49°C)	190°F (88°C)	180°F (82°C)	This Setpoint is used for DHW when the time-of-day switch is on.	
Off hysteresis	°F or °C	2°F (1°C)	10°F (6°C)	5°F (3°C)	The off hysteresis is added to the DHW Setpoint to determine the temperature at which DHW burner demand turns off.	
On hysteresis	°F or °C	2°F (1°C)	10°F (6°C)	5°F (3°C)	The on hysteresis is subtracted from the DHW Setpoint to determine the temperature at which DHW burner demand turns on.	
DHW priority override time	hr mm ss	0m 0s	720m 0s	60m 0s	If this parameter is non-zero then a DHW demand will shift its priority vs. other demand sources according to the specified time. The priority override timing is reset when demand from the DHW source turns off.	
DHW priority vs CH		DHW>CH or CH>DHW		DHW>CH	This parameter determines the priority of DHW vs. CH call-for-heat, when both of these are enabled and active. (The DHW priority also may shift for a period of time, as specified by DHW Priority time and method parameters.)	
DHW priority vs Lead Lag		DHW>Lead Lag or Lead Lag>DHW		DHW > Lead Lag	This parameter determines the priority of DHW vs. CH call-for-heat, when both of these are enabled and active. (The DHW priority also may shift for a period of time, as specified by DHW Priority time and method parameters.)	



# Sola control parameter table *(continued)*

HOME PAGE → → CONFIGURATION

**Figure 86** (continued) Sola CONFIGURATION VALUES — setup options — White text on black titles are configuration groups — see Figure 63, page 61 for location of configuration group in menus (**Enter changed values in the last column**)

Menu/Item	Units	Low Value	High Value	Default	Description	Changed to
<b>Warm Weather Shutdown Configuration</b>						
Warm Weather Shutdown Enable	°F	Enable or Disable		Disabled	Boiler does not fire on call for central heating if outdoor temperature is above this setting.	
Warm Weather Shutdown Setpoint	°F	-40	266	60°F	Outdoor air temperature that forces the maximum supply water to be target temperature	
<b>Modulation Configuration</b>						
CH maximum modulation rate	%   RPM	Model Specific			Provides the upper limit of analog output or fan speed during modulation when firing for CH or LL slave mode.	
DHW maximum modulation rate	%   RPM	Model Specific			Provides the upper limit of analog output or fan speed during modulation when firing for DHW.	
Minimum modulation rate	%   RPM	Model Specific			Provides the lower limit of analog output or fan speed during modulation.	
CH slow start enable				Disabled	This parameter enables or disables the slow start limit function for CH (or LL slave) demand.	
DHW slow start enable				Disabled	This parameter enables or disables the slow start limit function for DHW demand.	
Analog input hysteresis	mA   (10ths OK)	Not adjustable			Analog input hysteresis on 4-20mA input. There is no resistance to change in the same direction as the last change, but to reverse directions, the input change must exceed the value provided here.	
Analog rate tracking		See Description		Analog rate tracking disabled	Analog rate tracking, options: Analog rate tracking disabled Stand-alone rate (RPM) tracking 4-20mA Stand-alone rate (RPM) tracking 0-10V LL master rate tracking 4-20mA LL master rate tracking 0-10V	
<b>Pump Configuration</b>						
<b>Central Heat Pump main page</b>						
<i>(Use scroll arrows to toggle between Central Heat Pump, Boiler Pump, Domestic Hot Water Pump, System Pump, Auxiliary 1 Pump, and Auxiliary 2 Pump pages)</i>						
Pump control		Auto or ON		Auto	The Pump can be turned on manually, or it can be set to operate automatically. If it is turned on then it remains on until changed back to Auto. In Auto mode it operates according to the demand sources listed above and the overrun time.	
Pump output		Pump A, Pump B, Pump C or NONE		NONE	This parameter allows the Pump function to be disabled or to activate any of the three pump outputs on terminal strip D.	
Overrun time	hr mm ss	0h0m0s	18h0m0s	0h0m0s	This time indicates how long the Pump should remain on after demand from any source ends. That is, whenever the pump has been on, but the last requests for the pump to be on ends, it always continues to run for the time given by this parameter.	
Use for local demands		<input checked="" type="checkbox"/> or <input type="checkbox"/>		<input checked="" type="checkbox"/>	Enables pump demand from the local Sola: the one which contains this pump control block. If not enabled then all local Sola pump demands are ignored by this pump control block.	
Use for lead lag master demands		<input checked="" type="checkbox"/> or <input type="checkbox"/>		<input type="checkbox"/>	Enables the Sola LL Master's demands to operate this pump control block. If not enabled then all Sola LL Master demands are ignored by this pump control block	



# Sola control parameter table *(continued)*

HOME PAGE → → CONFIGURATION

**Figure 86** (continued) Sola CONFIGURATION VALUES — setup options — White text on black titles are configuration groups — see Figure 63, page 61 for location of configuration group in menus (**Enter changed values in the last column**)

Menu/Item	Units	Low Value	High Value	Default	Description	Changed to
<b>Central Heat Pump ADVANCED — ON OPTIONS tab</b>						
<i>(Use scroll arrows to toggle between Central Heat Pump, Boiler Pump, Domestic Hot Water Pump, System Pump, Auxiliary 1 Pump, and Auxiliary 2 Pump pages)</i>						
Central Heat: Demand		<input checked="" type="checkbox"/> or <input type="checkbox"/>		<input type="checkbox"/>	If CH is calling for heat (local or Sola LL master) then this pump will have normal pump-on demand. A CH call-for-heat will operate the pump even if some other service source (e.g. DHW) is actually in control of the boiler on higher priority.	
Central Heat: Service active		<input checked="" type="checkbox"/> or <input type="checkbox"/>		<input checked="" type="checkbox"/>	If CH is the active service (local or Sola LL master) controlling the heating system (has heat demand AND is in control) then this pump will have normal pump-on demand.	
DHW Service active		<input checked="" type="checkbox"/> or <input type="checkbox"/>		<input type="checkbox"/>	If DHW is the active service controlling the heating system (has heat demand AND is in control) then this pump will have normal pump-on demand.	
Local Lead Lag: Service active		<input checked="" type="checkbox"/> or <input type="checkbox"/>		<input type="checkbox"/>	This pump will respond when LL service is currently the highest priority service for this slave and the Sola LL master has commanded this slave Sola to start up and fire.	
Frost protection: Central Heat		<input checked="" type="checkbox"/> or <input type="checkbox"/>		<input checked="" type="checkbox"/>	If CH frost protection is active then this pump will have normal pump-on demand.	
Frost protection: DHW		<input checked="" type="checkbox"/> or <input type="checkbox"/>		<input type="checkbox"/>	If DHW frost protection is active then this pump will have normal pump-on demand.	
<b>Central Heat Pump ADVANCED — Force On tab — Force pump on when:</b>						
<i>(Use scroll arrows to toggle between Central Heat Pump, Boiler Pump, Domestic Hot Water Pump, System Pump, Auxiliary 1 Pump, and Auxiliary 2 Pump pages)</i>						
Local burner demand		<input checked="" type="checkbox"/> or <input type="checkbox"/>		<input type="checkbox"/>	If Local demands are enabled, then when the burner has demand (is firing or preparing to fire, always local) the output will be forced on. Example, this feature might be used to open a boiler room air damper (but does NOT implement airflow safety).	
Lead Lag slave demand		<input checked="" type="checkbox"/> or <input type="checkbox"/>		<input type="checkbox"/>	If Sola LL Master demand is enabled, then whenever the master is asking for heat from any slave, this output will be forced on. Example, this feature might be used to open a boiler room air damper (but does Not implement airflow safety).	
<b>Central Heat Pump ADVANCED — Miscellaneous tab</b>						
<i>(Use scroll arrows to toggle between Central Heat Pump, Boiler Pump, Domestic Hot Water Pump, System Pump, Auxiliary 1 Pump, and Auxiliary 2 Pump pages)</i>						
Local demand inhibited for faults		<input checked="" type="checkbox"/> or <input type="checkbox"/>		<input type="checkbox"/>	If the local Sola is disabled (e.g. via the burner switch parameter) or locked out, inhibit local demand sources (are selected) that might otherwise request the pump to be on. Otherwise these will run the pump even though the sola cannot fire.	
<b>Pump Configuration <i>(continued)</i></b>						
<b>Boiler Pump main page</b>						
<i>(Use scroll arrows to toggle between Boiler Pump, Boiler Pump, Domestic Hot Water Pump, System Pump, Auxiliary 1 Pump, and Auxiliary 2 Pump pages)</i>						
Pump control		Auto or ON		Auto	The Pump can be turned on manually, or it can be set to operate automatically. If it is turned on then it remains on until changed back to Auto. In Auto mode it operates according to the demand sources listed above and the overrun time.	
Pump output		Pump A, Pump B, Pump C or NONE		Pump A	This parameter allows the Pump function to be disabled or to activate any of the three pump outputs on terminal strip D.	
Overrun time	hr mm ss	0h 0m 0s		0h 0m 30s	This time indicates how long the Pump should remain on after demand from any source ends. That is, whenever the pump has been on, but the last requests for the pump to be on ends, it always continues to run for the time given by this parameter.	
Use for local demands		<input checked="" type="checkbox"/> or <input type="checkbox"/>		<input checked="" type="checkbox"/>	Enables pump demand from the local Sola: the one which contains this pump control block. If not enabled then all local Sola pump demands are ignored by this pump control block.	



# Sola control parameter table *(continued)*

HOME PAGE → → CONFIGURATION

**Figure 86** (continued) Sola CONFIGURATION VALUES — setup options — White text on black titles are configuration groups — see Figure 63, page 61 for location of configuration group in menus (**Enter changed values in the last column**)

Menu/Item	Units	Low Value	High Value	Default	Description	Changed to
Use for lead lag master demands		<input checked="" type="checkbox"/> or <input type="checkbox"/>		<input checked="" type="checkbox"/>	Enables the Sola LL Master's demands to operate this pump control lock. If not enabled then all Sola LL Master demands are ignored by this pump control block	
<b>Boiler Pump ADVANCED — ON OPTIONS tab</b>						
<i>(Use scroll arrows to toggle between Central Heat Pump, Boiler Pump, Domestic Hot Water Pump, System Pump, Auxiliary 1 Pump, and Auxiliary 2 Pump pages)</i>						
Central Heat: Service active		<input checked="" type="checkbox"/> or <input type="checkbox"/>		<input checked="" type="checkbox"/>	If DHW is the active service controlling the heating system (has heat demand AND is in control) then this pump will have normal pump-on demand.	
DHW Service active		<input checked="" type="checkbox"/> or <input type="checkbox"/>		<input type="checkbox"/>	If DHW is the active service controlling the heating system (has heat demand AND is in control) then this pump will have normal pump-on demand.	
Local Lead Lag: Service active		<input checked="" type="checkbox"/> or <input type="checkbox"/>		<input checked="" type="checkbox"/>	This pump will respond when LL service is currently the highest priority service for this slave and the Sola LL master has commanded this slave Sola to start up and fire.	
Frost protection: Central Heat		<input checked="" type="checkbox"/> or <input type="checkbox"/>		<input checked="" type="checkbox"/>	If CH frost protection is active then this pump will have normal pump-on demand.	
Frost protection: DHW		<input checked="" type="checkbox"/> or <input type="checkbox"/>		<input type="checkbox"/>	If DHW frost protection is active then this pump will have normal pump-on demand.	
<b>Boiler Pump ADVANCED — Force On tab — Force pump on when:</b>						
<i>(Use scroll arrows to toggle between Central Heat Pump, Boiler Pump, Domestic Hot Water Pump, System Pump, Auxiliary 1 Pump, and Auxiliary 2 Pump pages)</i>						
Local burner demand		<input checked="" type="checkbox"/> or <input type="checkbox"/>		<input type="checkbox"/>	If Local demands are enabled, then when the burner has demand (is firing or preparing to fire, always local) the output will be forced on. Example, this feature might be used to open a boiler room air damper (but does NOT implement airflow safety).	
Lead Lag slave demand		<input checked="" type="checkbox"/> or <input type="checkbox"/>		<input type="checkbox"/>	If Sola LL Master demand is enabled, then whenever the master is asking for heat from any slave, this output will be forced on. Example, this feature might be used to open a boiler room air damper (but does Not implement airflow safety).	
<b>Boiler Pump ADVANCED — Miscellaneous tab</b>						
<i>(Use scroll arrows to toggle between Central Heat Pump, Boiler Pump, Domestic Hot Water Pump, System Pump, Auxiliary 1 Pump, and Auxiliary 2 Pump pages)</i>						
Local demand inhibited for faults		<input checked="" type="checkbox"/> or <input type="checkbox"/>		<input type="checkbox"/>	If the local Sola is disabled (e.g. via the burner switch parameter) or locked out, inhibit local demand sources (are selected) that might otherwise request the pump to be on. Otherwise these will run the pump even though the sola cannot fire.	

<b>Pump Configuration <i>(continued)</i></b>						
<b>DHW Pump main page</b>						
<i>(Use scroll arrows to toggle between DHW Pump, Boiler Pump, Domestic Hot Water Pump, System Pump, Auxiliary 1 Pump, and Auxiliary 2 Pump pages)</i>						
Pump control		Auto or ON		Auto	The Pump can be turned on manually, or it can be set to operate automatically. If it is turned on then it remains on until changed back to Auto. In Auto mode it operates according to the demand sources listed above and the overrun time.	
Pump output		Pump A, Pump B, Pump C or NONE		Pump C	This parameter allows the Pump function to be disabled or to activate any of the three pump outputs on terminal strip D.	
Overrun time	hr mm ss	0h0m0s	18h0m0s	0h0m30s	This time indicates how long the Pump should remain on after demand from any source ends. That is, whenever the pump has been on, but the last requests for the pump to be on ends, it always continues to run for the time given by this parameter.	
Use for local demands		<input checked="" type="checkbox"/> or <input type="checkbox"/>		<input checked="" type="checkbox"/>	Enables pump demand from the local Sola: the one which contains this pump control block. If not enabled then all local Sola pump demands are ignored by this pump control block.	
Use for lead lag master demands		<input checked="" type="checkbox"/> or <input type="checkbox"/>		<input type="checkbox"/>	Enables the Sola LL Master's demands to operate this pump control lock. If not enabled then all Sola LL Master demands are ignored by this pump control block.	



# Sola control parameter table *(continued)*

HOME PAGE → → CONFIGURATION

**Figure 86** (continued) Sola CONFIGURATION VALUES — setup options — White text on black titles are configuration groups — see Figure 63, page 61 for location of configuration group in menus (**Enter changed values in the last column**)

Menu/Item	Units	Low Value	High Value	Default	Description	Changed to
<b>DHW Pump ADVANCED — ON OPTIONS tab</b>						
<i>(Use scroll arrows to toggle between Central Heat Pump, Boiler Pump, Domestic Hot Water Pump, System Pump, Auxiliary 1 Pump, and Auxiliary 2 Pump pages)</i>						
Central Heat: Service active		<input checked="" type="checkbox"/> or <input type="checkbox"/>		<input type="checkbox"/>	If DHW is the active service controlling the heating system (has heat demand AND is in control) then this pump will have normal pump-on demand.	
DHW: Demand		<input checked="" type="checkbox"/> or <input type="checkbox"/>		<input type="checkbox"/>	If DHW is calling for heat then this pump will have normal pump-on demand. A DHW call-for-heat will operate the pump even if some other service source (e.g. CH) is actually in control of the boiler on higher priority.	
DHW: Service active		<input checked="" type="checkbox"/> or <input type="checkbox"/>		<input checked="" type="checkbox"/>	If DHW is the active service controlling the heating system (has heat demand AND is in control) then this pump will have normal pump-on demand.	
Local Lead Lag: Service active		<input checked="" type="checkbox"/> or <input type="checkbox"/>		<input type="checkbox"/>	This pump will respond when LL service is currently the highest priority service for this slave and the Sola LL master has commanded this slave Sola to start up and fire.	
Frost protection: Central Heat		<input checked="" type="checkbox"/> or <input type="checkbox"/>		<input type="checkbox"/>	If CH frost protection is active then this pump will have normal pump-on demand.	
Frost protection: DHW		<input checked="" type="checkbox"/> or <input type="checkbox"/>		<input checked="" type="checkbox"/>	If DHW frost protection is active then this pump will have normal pump-on demand.	
<b>DHW Pump ADVANCED — Force On tab — Force pump on when:</b>						
<i>(Use scroll arrows to toggle between Central Heat Pump, Boiler Pump, Domestic Hot Water Pump, System Pump, Auxiliary 1 Pump, and Auxiliary 2 Pump pages)</i>						
Local burner demand		<input checked="" type="checkbox"/> or <input type="checkbox"/>		<input type="checkbox"/>	If Local demands are enabled, then when the burner has demand (is firing or preparing to fire, always local) the output will be forced on. Example, this feature might be used to open a boiler room air damper (but does NOT implement airflow safety).	
Lead Lag slave demand		<input checked="" type="checkbox"/> or <input type="checkbox"/>		<input type="checkbox"/>	If Sola LL Master demand is enabled, then whenever the master is asking for heat from any slave, this output will be forced on. Example, this feature might be used to open a boiler room air damper (but does Not implement airflow safety).	
<b>DHW Pump ADVANCED — Miscellaneous tab</b>						
<i>(Use scroll arrows to toggle between Central Heat Pump, Boiler Pump, Domestic Hot Water Pump, System Pump, Auxiliary 1 Pump, and Auxiliary 2 Pump pages)</i>						
Local demand inhibited for faults		<input checked="" type="checkbox"/> or <input type="checkbox"/>		<input type="checkbox"/>	If the local Sola is disabled (e.g. via the burner switch parameter) or locked out, inhibit local demand sources (are selected) that might otherwise request the pump to be on. Otherwise these will run the pump even though the sola cannot fire.	
<b>Pump Configuration <i>(continued)</i></b>						
<b>System Pump main page</b>						
<i>(Use scroll arrows to toggle between System Pump, Boiler Pump, Domestic Hot Water Pump, System Pump, Auxiliary 1 Pump, and Auxiliary 2 Pump pages)</i>						
Pump control		Auto or ON		Auto	The Pump can be turned on manually, or it can be set to operate automatically. If it is turned on then it remains on until changed back to Auto. In Auto mode it operates according to the demand sources listed above and the overrun time.	
Pump output		Pump A, Pump B, Pump C or NONE		Pump B	This parameter allows the Pump function to be disabled or to activate any of the three pump outputs on terminal strip D.	
Overrun time	hr mm ss	0h0m0s	18h0m0s	0h0m0s	This time indicates how long the Pump should remain on after demand from any source ends. That is, whenever the pump has been on, but the last requests for the pump to be on ends, it always continues to run for the time given by this parameter.	
Use for local demands		<input checked="" type="checkbox"/> or <input type="checkbox"/>		<input checked="" type="checkbox"/>	Enables pump demand from the local Sola: the one which contains this pump control block. If not enabled then all local Sola pump demands are ignored by this pump control block.	



# Sola control parameter table *(continued)*

HOME PAGE → → CONFIGURATION

**Figure 86** (continued) Sola CONFIGURATION VALUES — setup options — White text on black titles are configuration groups — see Figure 63, page 61 for location of configuration group in menus (**Enter changed values in the last column**)

Menu/Item	Units	Low Value	High Value	Default	Description	Changed to
Use for lead lag master demands		<input checked="" type="checkbox"/> or <input type="checkbox"/>		<input checked="" type="checkbox"/>	Enables the Sola LL Master's demands to operate this pump control block. If not enabled then all Sola LL Master demands are ignored by this pump control block.	
<b>System Pump ADVANCED — ON OPTIONS tab</b>						
<i>(Use scroll arrows to toggle between Central Heat Pump, Boiler Pump, Domestic Hot Water Pump, System Pump, Auxiliary 1 Pump, and Auxiliary 2 Pump pages)</i>						
Central Heat: Demand		<input checked="" type="checkbox"/> or <input type="checkbox"/>		<input type="checkbox"/>	If CH is calling for heat (local or Sola LL master) then this pump will have normal pump-on demand. A CH call-for-heat will operate the pump even if some other service source (e.g. DHW) is actually in control of the boiler on higher priority.	
Central Heat: Service active		<input checked="" type="checkbox"/> or <input type="checkbox"/>		<input checked="" type="checkbox"/>	If CH is the active service (local or Sola LL master) controlling the heating system (has heat demand AND is in control) then this pump will have normal pump-on demand.	
DHW: Demand		<input checked="" type="checkbox"/> or <input type="checkbox"/>		<input type="checkbox"/>	If DHW is calling for heat then this pump will have normal pump-on demand. A DHW call-for-heat will operate the pump even if some other service source (e.g. CH) is actually in control of the boiler on higher priority.	
DHW Service active		<input checked="" type="checkbox"/> or <input type="checkbox"/>		<input type="checkbox"/>	If DHW is the active service controlling the heating system (has heat demand AND is in control) then this pump will have normal pump-on demand.	
Local Lead Lag: Service active		<input checked="" type="checkbox"/> or <input type="checkbox"/>		<input type="checkbox"/>	This pump will respond when LL service is currently the highest priority service for this slave and the Sola LL master has commanded this slave Sola to start up and fire.	
Frost protection: Central Heat		<input checked="" type="checkbox"/> or <input type="checkbox"/>		<input checked="" type="checkbox"/>	If CH frost protection is active then this pump will have normal pump-on demand.	
Frost protection: DHW		<input checked="" type="checkbox"/> or <input type="checkbox"/>		<input type="checkbox"/>	If DHW frost protection is active then this pump will have normal pump-on demand.	
<b>System Pump ADVANCED — Force On tab — Force pump on when:</b>						
<i>(Use scroll arrows to toggle between Central Heat Pump, Boiler Pump, Domestic Hot Water Pump, System Pump, Auxiliary 1 Pump, and Auxiliary 2 Pump pages)</i>						
Local burner demand		<input checked="" type="checkbox"/> or <input type="checkbox"/>		<input type="checkbox"/>	If Local demands are enabled, then when the burner has demand (is firing or preparing to fire, always local) the output will be forced on. Example, this feature might be used to open a boiler room air damper (but does NOT implement airflow safety).	
Lead Lag slave demand		<input checked="" type="checkbox"/> or <input type="checkbox"/>		<input type="checkbox"/>	If Sola LL Master demand is enabled, then whenever the master is asking for heat from any slave, this output will be forced on. Example, this feature might be used to open a boiler room air damper (but does Not implement airflow safety).	
<b>System Pump ADVANCED — Miscellaneous tab</b>						
<i>(Use scroll arrows to toggle between Central Heat Pump, Boiler Pump, Domestic Hot Water Pump, System Pump, Auxiliary 1 Pump, and Auxiliary 2 Pump pages)</i>						
Local demand inhibited for faults		<input checked="" type="checkbox"/> or <input type="checkbox"/>		<input type="checkbox"/>	If the local Sola is disabled (e.g. via the burner switch parameter) or locked out, inhibit local demand sources (are selected) that might otherwise request the pump to be on. Otherwise these will run the pump even though the sola cannot fire.	

<b>Pump Configuration <i>(continued)</i></b>						
<b>Auxiliary 1 Pump main page</b>						
<i>(Use scroll arrows to toggle between Aux 1 Pump, Boiler Pump, Domestic Hot Water Pump, System Pump, Auxiliary 1 Pump, and Auxiliary 2 Pump pages)</i>						
Pump control		Auto or ON		Auto	The Pump can be turned on manually, or it can be set to operate automatically. If it is turned on then it remains on until changed back to Auto. In Auto mode it operates according to the demand sources listed above and the overrun time.	
Pump output		Pump A, Pump B, Pump C or NONE		NONE	This parameter allows the Pump function to be disabled or to activate any of the three pump outputs on terminal strip D.	
Pump start delay		0h0m0s	18h0m0s	0h0m0s	This time indicates how long the pump should remain off after demand is initiated.	



# Sola control parameter table *(continued)*

HOME PAGE → → CONFIGURATION

**Figure 86** (continued) Sola CONFIGURATION VALUES — setup options — White text on black titles are configuration groups — see Figure 63, page 61 for location of configuration group in menus (**Enter changed values in the last column**)

Menu/Item	Units	Low Value	High Value	Default	Description	Changed to
Overrun time	hr mm ss	0h0m0s	18h0m0s	0h0m0s	This time indicates how long the Pump should remain on after demand from any source ends. That is, whenever the pump has been on, but the last requests for the pump to be on ends, it always continues to run for the time given by this parameter.	
Use for local demands		<input checked="" type="checkbox"/> or <input type="checkbox"/>		<input checked="" type="checkbox"/>	Enables pump demand from the local Sola: the one which contains this pump control block. If not enabled then all local Sola pump demands are ignored by this pump control block.	
Use for lead lag master demands		<input checked="" type="checkbox"/> or <input type="checkbox"/>		<input checked="" type="checkbox"/>	Enables the Sola LL Master's demands to operate this pump control block. If not enabled then all Sola LL Master demands are ignored by this pump control block.	
<b>Auxiliary 1 Pump ADVANCED — Force On tab — Force pump on when:</b> <i>(Use scroll arrows to toggle between Central Heat Pump, Boiler Pump, Domestic Hot Water Pump, System Pump, Auxiliary 1 Pump, and Auxiliary 2 Pump pages)</i>						
Local burner demand		<input checked="" type="checkbox"/> or <input type="checkbox"/>		<input checked="" type="checkbox"/>	If Local demands are enabled, then when the burner has demand (is firing or preparing to fire, always local) the output will be forced on. Example, this feature might be used to open a boiler room air damper (but does NOT implement airflow safety).	
Lead Lag slave demand		<input checked="" type="checkbox"/> or <input type="checkbox"/>		<input checked="" type="checkbox"/>	If Sola LL Master demand is enabled, then whenever the master is asking for heat from any slave, this output will be forced on. Example, this feature might be used to open a boiler room air damper (but does Not implement airflow safety).	

<b>Pump Configuration <i>(continued)</i></b>						
<b>Auxiliary 2 Pump main page</b> <i>(Use scroll arrows to toggle between Auxiliary 2 Pump, Boiler Pump, Domestic Hot Water Pump, System Pump, Auxiliary 1 Pump, and Auxiliary 2 Pump pages)</i>						
Pump control		Auto or ON		Auto	The Pump can be turned on manually, or it can be set to operate automatically. If it is turned on then it remains on until changed back to Auto. In Auto mode it operates according to the demand sources listed above and the overrun time.	
Pump output		Pump A, Pump B, Pump C or NONE		NONE	This parameter allows the Pump function to be disabled or to activate any of the three pump outputs on terminal strip D.	
Pump start delay		0h0m0s	18h0m0s	0h0m0s	This time indicates how long the pump should remain off after demand is initiated.	
Overrun time	hr mm ss	0h0m0s	18h0m0s	0h0m0s	This time indicates how long the Pump should remain on after demand from any source ends. That is, whenever the pump has been on, but the last requests for the pump to be on ends, it always continues to run for the time given by this parameter.	
Use for local demands		<input checked="" type="checkbox"/> or <input type="checkbox"/>		<input type="checkbox"/>	Enables pump demand from the local Sola: the one which contains this pump control block. If not enabled then all local Sola pump demands are ignored by this pump control block.	
Use for lead lag master demands		<input checked="" type="checkbox"/> or <input type="checkbox"/>		<input type="checkbox"/>	Enables the Sola LL Master's demands to operate this pump control block. If not enabled then all Sola LL Master demands are ignored by this pump control block.	
<b>Auxiliary 2 Pump ADVANCED — ON OPTIONS tab</b> <i>(Use scroll arrows to toggle between Central Heat Pump, Boiler Pump, Domestic Hot Water Pump, System Pump, Auxiliary 1 Pump, and Auxiliary 2 Pump pages)</i>						
Central Heat: Demand		<input checked="" type="checkbox"/> or <input type="checkbox"/>		<input type="checkbox"/>	If CH is calling for heat (local or Sola LL master) then this pump will have normal pump-on demand. A CH call-for-heat will operate the pump even if some other service source (e.g. DHW) is actually in control of the boiler on higher priority.	
Central Heat: Service active		<input checked="" type="checkbox"/> or <input type="checkbox"/>		<input type="checkbox"/>	If CH is the active service (local or Sola LL master) controlling the heating system (has heat demand AND is in control) then this pump will have normal pump-on demand.	
DHW: Demand		<input checked="" type="checkbox"/> or <input type="checkbox"/>		<input type="checkbox"/>	If DHW is calling for heat then this pump will have normal pump-on demand. A DHW call-for-heat will operate the pump even if some other service source (e.g. CH) is actually in control of the boiler on higher priority.	



# Sola control parameter table *(continued)*

HOME PAGE → → CONFIGURATION

**Figure 86** (continued) Sola CONFIGURATION VALUES — setup options — White text on black titles are configuration groups — see Figure 63, page 61 for location of configuration group in menus (**Enter changed values in the last column**)

Menu/Item	Units	Low Value	High Value	Default	Description	Changed to
DHW Service active		<input checked="" type="checkbox"/> or <input type="checkbox"/>		<input type="checkbox"/>	If DHW is the active service controlling the heating system (has heat demand AND is in control) then this pump will have normal pump-on demand.	
Local Lead Lag: Demand		<input checked="" type="checkbox"/> or <input type="checkbox"/>		<input type="checkbox"/>	This pump will respond if the Sola LL master has heat demand and therefore sends a LL pump demand request to this Sola because it is the lead slave (it also will have LL service as the highest priority, otherwise some other Sola would be the lead).	
Local Lead Lag: Service active		<input checked="" type="checkbox"/> or <input type="checkbox"/>		<input type="checkbox"/>	This pump will respond when LL service is currently the highest priority service for this slave and the Sola LL master has commanded this slave Sola to start up and fire.	
Frost protection: Central Heat		<input checked="" type="checkbox"/> or <input type="checkbox"/>		<input type="checkbox"/>	If CH frost protection is active then this pump will have normal pump-on demand.	
Frost protection: DHW		<input checked="" type="checkbox"/> or <input type="checkbox"/>		<input type="checkbox"/>	If DHW frost protection is active then this pump will have normal pump-on demand.	
<b>Auxiliary 2 Pump ADVANCED — Force On tab — Force pump on when:</b>						
<i>(Use scroll arrows to toggle between Central Heat Pump, Boiler Pump, Domestic Hot Water Pump, System Pump, Auxiliary 1 Pump, and Auxiliary 2 Pump pages)</i>						
Local burner demand		<input checked="" type="checkbox"/> or <input type="checkbox"/>		<input type="checkbox"/>	If Local demands are enabled, then when the burner has demand (is firing or preparing to fire, always local) the output will be forced on. Example, this feature might be used to open a boiler room air damper (but does NOT implement airflow safety).	
Outlet High Limit		<input checked="" type="checkbox"/> or <input type="checkbox"/>		<input type="checkbox"/>	If Local demands are enabled, then when the Outlet High Limit condition is active (always local) this pump will be forced on.	
Lead Lag slave demand		<input checked="" type="checkbox"/> or <input type="checkbox"/>		<input type="checkbox"/>	If Sola LL Master demand is enabled, then whenever the master is asking for heat from any slave, this output will be forced on. Example, this feature might be used to open a boiler room air damper (but does Not implement airflow safety).	
<b>Auxiliary 2 Pump ADVANCED — Force OFF tab — Force pump off when:</b>						
<i>(Use scroll arrows to toggle between Central Heat Pump, Boiler Pump, Domestic Hot Water Pump, System Pump, Auxiliary 1 Pump, and Auxiliary 2 Pump pages)</i>						
DHW priority is active		<input checked="" type="checkbox"/> or <input type="checkbox"/>		<input type="checkbox"/>	Forces pump off when DHW is active priority.	
<b>Auxiliary 2 Pump ADVANCED — Miscellaneous tab</b>						
<i>(Use scroll arrows to toggle between Central Heat Pump, Boiler Pump, Domestic Hot Water Pump, System Pump, Auxiliary 1 Pump, and Auxiliary 2 Pump pages)</i>						
Local demand inhibited for faults		<input checked="" type="checkbox"/> or <input type="checkbox"/>		<input type="checkbox"/>	If the local Sola is disabled (e.g. via the burner switch parameter) or locked out, inhibit local demand sources (are selected) that might otherwise request the pump to be on. Otherwise these will run the pump even though the sola cannot fire.	

<b>Statistics Configuration</b>						
Burner cycles		0		0	Number of burner cycles since last reset to 0	
Burner run time	Hrs	0		0	Accumulated burner run time since last reset to 0	
CH pump cycles		0		0	Number of CH pump cycles since last reset to 0	
DHW pump cycles		0		0	Number of DHW pump cycles since last reset to 0	
Boiler pump cycles		0		0	Number of boiler pump cycles since last reset to 0	

<b>High Limits <i>(read only — not changeable)</i></b>						
Outlet high limit response		Not changeable		Lockout	For Recycle and Delay, the burner control recycles and holds while waiting for a delay (see the Stack Limit Delay parameter) to expire, and after the delay it tries again.	
Outlet high limit setpoint		Not changeable		200°F	If the stack temperature exceeds the temperature given by this parameter then the response defined for the Stack Limit Response parameter will occur. As the temperature approaches this limit, the Stepped Modulation Limiting function is active.	





# Sola control parameter table *(continued)*

HOME PAGE → → CONFIGURATION

**Figure 86** (continued) Sola CONFIGURATION VALUES — setup options — White text on black titles are configuration groups — see Figure 63, page 61 for location of configuration group in menus (**Enter changed values in the last column**)

Menu/Item	Units	Low Value	High Value	Default	Description	Changed to
<b>Frost Protection Configuration</b>						
CH frost protection enable		Enable or Disable	Disabled	Disabled	The CH frost protection feature can be enabled to run a pump (or pumps) and possibly fire the burner whenever the CH input sensor is too cold.	
DHW frost protection enable		Enable or Disable	Disabled	Disabled	The DHW frost protection feature can be enabled to run a pump (or pumps) and possibly fire the burner whenever the DHW input sensor is too cold.	
LL frost protection enable		Enable or Disable	Disabled	Disabled	The LL frost protection feature can be enabled to run a pump (or pumps) and possibly fire the burner whenever the LL input sensor is too cold.	
Outdoor frost protection setpoint	°F or °C	-40°F	266°F	32°F (0°C)	This parameter provides the setpoint for frost protection based on outdoor temperature. When the outdoor temperature falls below this threshold then frost protection will be active.	
LL frost protection rate	%	0%	100%	0%	Sets firing rate during frost protection cycle.	
CH Pump frost overrun time	hr mm ss	0h0m0s	18h0m0s	0h 1m0s	This time indicates how long pump demand should remain on after frost protection ends. That is, any pump configured to respond to frost protection will continue to run after frost protection ends, for the amount of time given by this parameter.	
DHW Pump frost overrun time	hr mm ss	0h0m0s	18h0m0s	0h 1m0s	This time indicates how long pump demand should remain on after frost protection ends. That is, any pump configured to respond to frost protection will continue to run after frost protection ends, for the amount of time given by this parameter.	
<b>Annunciation Configuration</b>						
Annunciator		Not changeable			Drop-down list of monitored devices	
Location		Not changeable			Sola control input location (shows the circuit in which the device is wired)	
Short name		Not changeable			Abbreviated device name	
Name		Not changeable			Complete device name	
<b>Burner Control Timings &amp; Rates</b>						
Lightoff rate	RPM	Varies by boiler model			This parameter specifies the analog output or fan speed used during Ignition.	
<b>Burner Control Ignition</b> <i>(read only — not changeable)</i>						
Pilot test hold		Not changeable	OFF	OFF	Does not apply to SlimFit boiler	
Flame threshold		Not changeable	0.2			
<b>Burner Control Flame Failure</b> <i>(read only — not changeable)</i>						
Ignite failure response		Not changeable	Retry N times, then lockout		If ignition fails then several responses are possible. This parameter selects one of these responses.	
Ignite failure delay		Not changeable	1 min		When Recycle && Hold after Retries is selected as the response for an ignition failure, this parameter provides the delay time for the Standby hold.	
Ignite failure retries		Not changeable	1 retry		This parameter provides the number of retries allowed for an ignition failure, if the response to failure of ignition includes retries.	
Run flame failure response		Not changeable	Recycle		If flame fails in Run and recycle is selected then the burner control recycles back to the beginning of Prepurge, then continues with the normal burner startup process to attempt to light the burner again.	



# Sola control parameter table *(continued)*

HOME PAGE → → CONFIGURATION

**Figure 86** (continued) Sola CONFIGURATION VALUES — setup options — White text on black titles are configuration groups — see Figure 63, page 61 for location of configuration group in menus (**Enter changed values in the last column**)

Menu/Item	Units	Low Value	High Value	Default	Description	Changed to
<b>System Configuration</b>						
Temperature units		Fahrenheit or Centigrade		Fahrenheit	This parameter determines whether temperature is represented in units of Fahrenheit or Celsius degrees.	
Anti short-cycle time	hr mm ss	0h0m0s	18h0m0s	0h1m0s	Whenever the burner is turned off due to no demand the anti-short-cycle timer is started and the burner remains in a Standby Delay condition waiting for this time to expire. Does not apply, however, to recycle events or DHW demand.	
Burner switch		ON or OFF		ON	This parameter enables or disables the burner control. When it is off, the burner will not fire.	
Low fire cutoff time		Not changeable		0h0m0s		
Burner off inhibit time	hr mm ss	0h0m0s	0h10m0s	0h0m0s	Burner is forced to remain on at low fire for this amount of time before shut-off.	
Line frequency		Not changeable			Auto detects frequency, accepting 48 through 63 hz	
<b>Sensor Configuration</b>						
Outdoor temperature source		See description		S5	Configures which source to get Outdoor temperature data from: S5 sensor (terminal strip C), S10 sensor, Enviracom sensor, or Modbus communication.	
Outdoor temperature correction offset		-72°F	-72°F	0	Value to compensate for outdoor sensor accuracy; variations can occur due to solar gain or other factors.	
<b>Lead Lag Slave Configuration</b>						
Slave enable		Enable or disable		Disabled	Enables boiler as lead lag slave — options are Disabled or Enable slave for built-in lead lag master	
Slave mode				Equalize runtime	Each slave burner can specify how it should be handled by the Lead Lag master's sequencer. This parameter selects one of those methods. Options are: Equalize runtime, Use first according to priority, or Use last according to priority	
Base load rate	%	0%	100%	40%	Until all boilers are firing - No boiler is requested to exceed the common base load rate.	
Slave sequence order		1	8	0	Initial order for firing slave boiler	
Demand to firing delay	mm ss	0m 0s	20m 0s	10m 0s	This delay time is needed by the LL master to determine the length of time to wait between requesting a slave SOLA to fire and detecting that it has failed to start. It should be set to the total time normally needed for the burner to transition from Standby to Run, including such things as transition to purge rate, prepurge time, transition to lightoff rate, all ignition timings, and include some extra margin.	
Fan rate during off cycle	%	0%	100%	0	This determines if or where the fan is to be operating during the standby period.	
Modbus port		MB1	MB2	MB1	Modbus port for communication between boiler and master; options are MB1, MB2 or No Port	
Modbus address		1	8	0	Select an address number for this boiler; unique from others on the lead lag system.	



# Sola control parameter table *(continued)*

HOME PAGE → → CONFIGURATION

**Figure 86** (continued) Sola CONFIGURATION VALUES — setup options — White text on black titles are configuration groups — see Figure 63, page 61 for location of configuration group in menus (**Enter changed values in the last column**)

Menu/Item	Units	Low Value	High Value	Default	Description	Changed to
<b>Lead Lag Master Configuration</b>						
<b>Lead Lag Master Configuration main page</b>						
Master enable		Enable or Disable		Disable	Enable if this boiler is to be the master for the lead lag system.	
CH setpoint (set here or in Central Heat tab)	°F or °C	70°F (21°C)	190°F (88°C)	170°F (77°C)	This Setpoint is used when the time-of-day input is off. If the ODR function is active, this Setpoint provides one coordinate for the outdoor reset curve, as described for the CH Outdoor Reset parameter.	
CH time of day setpoint (set here or in Central Heat tab)	°F or °C	70°F (21°C)	190°F (88°C)	160°F (71°C)	This Setpoint is used when the time-of-day input is on. If the ODR function is active, this Setpoint provides one coordinate for the shifted (because TOD is on) outdoor reset curve, as described for the CH Outdoor Reset parameter.	
DHW setpoint (set here or in DHW tab)	°F or °C	120°F (49°C)	190°F (88°C)	190°F (88°C)	This Setpoint is used for DHW whenever the time-of-day switch is off or not connected (unused).	
DHW time of day setpoint (set here or in DHW tab)	°F or °C	120°F (49°C)	190°F (88°C)	No setting	This Setpoint is used for DHW when the time-of-day switch is on.	
Modbus port		See description		Use MB2	<ul style="list-style-type: none"> <li>• Use MBI port for Lead Lag messaging</li> <li>• Unassigned Modbus port</li> <li>• Use MB2 port for Lead Lag messaging</li> </ul>	
Operation enable		ON or OFF		ON	Enable or disable lead lag operation.	
<b>Lead Lag Master Configuration ADVANCED — Central Heat tab</b>						
<i>(Use scroll arrows to toggle between Central Heat, Domestic Hot Water, Mix, Frost Protection, Outdoor reset, Warm Weather Shutdown, Algorithms, Rate Allocation, Add Stage, Drop Stage and Modulation pages)</i>						
Demand switch		See description		STAT	Input to call for space heating — options: <ul style="list-style-type: none"> <li>• STAT terminal</li> <li>• CH loop is disabled</li> <li>• Modulation sensor below ON setpoint</li> </ul>	
Setpoint source		See description		Local setpoint	<ul style="list-style-type: none"> <li>• Local setpoint is used (setpoint is determined by the Sola control)</li> <li>• 4-20mA (S2) setpoint is used (setpoint is based on analog input)</li> </ul>	
Setpoint	°F or °C	70°F (21°C)	190°F (88°C)	170°F (77°C)	This Setpoint is used when the time-of-day input is off. If the ODR function is active, this Setpoint provides one coordinate for the outdoor reset curve, as described for the CH Outdoor Reset parameter.	
Time of day setpoint	°F or °C	70°F (21°C)	190°F (88°C)	160°F (71°C)	This Setpoint is used when the time-of-day input is on. If the ODR function is active, this Setpoint provides one coordinate for the shifted (because TOD is on) outdoor reset curve, as described for the CH Outdoor Reset parameter.	
4 mA water temperature	°F or °C	60°F (16°C)	190°F (88°C)	No setting	Analog input, Setpoint operation — Sets the water temperature setting at an analog input of 4mA.	
20 mA water temperature	°F or °C	60°F (16°C)	190°F (88°C)	No setting	Analog input, Setpoint operation — Sets the water temperature setting at an analog input of 20mA.	
<b>Lead Lag Master Configuration ADVANCED — Domestic Hot Water tab</b>						
<i>(Use scroll arrows to toggle between Central Heat, Domestic Hot Water, Mix, Frost Protection, Outdoor reset, Warm Weather Shutdown, Algorithms, Rate Allocation, Add Stage, Drop Stage and Modulation pages)</i>						
Demand switch		See description		Disabled	DHW call for heat source: Disabled or S6 (DHW terminals on terminal strip C)	
Setpoint	°F or °C	120°F (49°C)	190°F (88°C)	190°F (88°C)	This Setpoint is used for DHW whenever the time-of-day switch is off or not connected (unused).	
Time of day setpoint	°F or °C	120°F (49°C)	190°F (88°C)	No setting	This Setpoint is used for DHW when the time-of-day switch is on.	
Priority source		See description		DHW Heat Demand	DHW Heat demand or Disabled (disables DHW priority)	
Priority method		See description		Drop after priority time	Boost DHW during priority time Drop after priority time	



# Sola control parameter table *(continued)*

HOME PAGE → → CONFIGURATION

**Figure 86** (continued) Sola CONFIGURATION VALUES — setup options — White text on black titles are configuration groups — see Figure 63, page 61 for location of configuration group in menus (**Enter changed values in the last column**)

Menu/Item	Units	Low Value	High Value	Default	Description	Changed to
DHW priority override time	hr mm ss	0m 0s	720m 0s	60m 0s	If this parameter is non-zero then a DHW demand will shift its priority vs. other demand sources according to the specified time. The priority override timing is reset when demand from the DHW source turns off.	
DHW has priority over CH?		DHW>CH or CH>DHW		DHW>CH	This parameter determines the priority of DHW vs. CH call-for-heat, when both of these are enabled and active. (The DHW priority also may shift for a period of time, as specified by DHW Priority time and method parameters.)	
<b>Lead Lag Master Configuration ADVANCED — Frost Protection tab</b>						
<i>(Use scroll arrows to toggle between Central Heat, Domestic Hot Water, Mix, Frost Protection, Outdoor reset, Warm Weather Shutdown, Algorithms, Rate Allocation, Add Stage, Drop Stage and Modulation pages)</i>						
Enable		Enable or Disable		Disabled	Enables automatic operation of boiler	
Outdoor setpoint	°F or °C	-40°F (-40°C)	32°F (0°C)	32°F (0°C)	This parameter provides the setpoint for frost protection based on outdoor temperature. When the outdoor temperature falls below this threshold then frost protection will be active.	
Frost protection rate	%	0	100	0%	Sets firing rate during frost protection cycle.	
<b>Lead Lag Master Configuration ADVANCED — Outdoor Reset tab</b>						
<i>(Use scroll arrows to toggle between Central Heat, Domestic Hot Water, Mix, Frost Protection, Outdoor reset, Warm Weather Shutdown, Algorithms, Rate Allocation, Add Stage, Drop Stage and Modulation pages)</i>						
Enable		Enable or Disable		Enabled	If outdoor reset is enabled, then the current outdoor temperature is used to determine the Setpoint by interpolation using CH Setpoint (or CH Time-Of-Day Setpoint if TOD is on), the low water temperature, and the min and max outdoor temperatures.	
Maximum outdoor temperature	°F or °C	50°F (10°C)	100°F (38°C)	80°F (27°C)	This parameter determines the maximum outdoor temperature for the CH outdoor reset graph. At or above the maximum outdoor temperature, the water temperature setpoint will be at the low water temperature.	
Minimum outdoor temperature	°F or °C	-40°F (-40°C)	100°F (38°C)	0°F (-18°C)	This parameter determines the X coordinate of one point on the CH outdoor reset graph. At this outdoor temperature the setpoint will be the CH setpoint (or the CH TOD setpoint, if TOD is on).	
Low water temperature	°F or °C	60°F (16°C)	190°F (88°C)	120°F (49°C)	This parameter provides the CH outdoor reset setpoint when the outdoor temperature is at or above the maximum specified by the Max outdoor temperature.	
Minimum boiler water temperature	°F or °C	60°F (16°C)	190°F (88°C)	0°F (-18°C)	The Sola control will always use a setpoint at least as warm as this setting, even when the reset curve would call for a lower temperature.	
Outdoor boost time	mm ss	0m 0s	60m 0s	0m 0s	When CH outdoor reset is active and demand has not been met for a period of time, then the setpoint is boosted, and when demand is met, it steps back toward normal. This parameter provides the time interval for each step, both up and down.	
Outdoor boost step	°F or °C	0°F (-32°C)	20°F (11°C)	5°F (3°C)	Number of degrees to increase setpoint temperature with each boost.	
Outdoor boost maximum off point	°F or °C	70°F (21°C)	190°F (88°C)	Unconfigured	This limits the maximum setpoint temperature, preventing setpoint from exceeding this value when setpoint is increased due to Boost.	
SHOW LINE					Press this button to see a graph of the reset curve.	
<b>Lead Lag Master Configuration ADVANCED — Warm Weather Shutdown tab</b>						
<i>(Use scroll arrows to toggle between Central Heat, Domestic Hot Water, Mix, Frost Protection, Outdoor reset, Warm Weather Shutdown, Algorithms, Rate Allocation, Add Stage, Drop Stage and Modulation pages)</i>						
Enable	°F	Enable or Disable		Disabled	Boiler does not fire on call for central heating if outdoor temperature is above this setting.	
Setpoint	°F	-40°F (40°C)	266°F (130°C)	60°F (15°C)	Outdoor air temperature that forces the maximum supply water to be target temperature	



# Sola control parameter table *(continued)*

HOME PAGE → → CONFIGURATION

**Figure 86** (continued) Sola CONFIGURATION VALUES — setup options — White text on black titles are configuration groups — see Figure 63, page 61 for location of configuration group in menus (**Enter changed values in the last column**)

Menu/Item	Units	Low Value	High Value	Default	Description	Changed to
<b>Lead Lag Master Configuration ADVANCED — Algorithms tab</b>						
<i>(Use scroll arrows to toggle between Central Heat, Domestic Hot Water, Mix, Frost Protection, Outdoor reset, Warm Weather Shutdown, Algorithms, Rate Allocation, Add Stage, Drop Stage and Modulation pages)</i>						
Lead selection method		See description		Lowest measured run time	<ul style="list-style-type: none"> <li>Lowest measured run time or</li> <li>Rotate in sequence order</li> </ul>	
Lag selection method		See description		Lowest measured run time	<ul style="list-style-type: none"> <li>Lowest measured run time or</li> <li>Rotate in sequence order</li> </ul>	
Lead rotation time	day hr min	0d 0h 0m	45d 0h 0m	1d 0h 0m	Toggles lead boiler after this time has elapsed	
Force lead rotation time	day hr min	0d 0h 0m	45d 0h 0m	0d 0h 0m	Forces lead lag rotation	
<b>Lead Lag Master Configuration ADVANCED — Rate Allocation tab</b>						
<i>(Use scroll arrows to toggle between Central Heat, Domestic Hot Water, Mix, Frost Protection, Outdoor reset, Warm Weather Shutdown, Algorithms, Rate Allocation, Add Stage, Drop Stage and Modulation pages)</i>						
Base load rate	%	0%	100%	40%	Until all boilers are firing - No boiler is requested to exceed the common base load rate.	
<b>Lead Lag Master Configuration ADVANCED — Add Stage tab</b>						
<i>(Use scroll arrows to toggle between Central Heat, Domestic Hot Water, Mix, Frost Protection, Outdoor reset, Warm Weather Shutdown, Algorithms, Rate Allocation, Add Stage, Drop Stage and Modulation pages)</i>						
Method I		See description		Use error threshold	<ul style="list-style-type: none"> <li>Use error threshold to add stage or</li> <li>Do not add stage</li> </ul>	
Detection time I	hr mm ss	0h 0m 0s	0h 10m 0s	0h 2m 0s	Delay before adding a stage once temperature has dropped to setpoint minus the error threshold.	
Error threshold	°F or °C	2	20	10°F (6°C)	Temperature drop below setpoint required before more stages are added.	
Inter-stage delay	hr mm ss	0h 0m 0s	18h 0m 0s	0h 2m 0s	Minimum time after a stage is added before another stage can be added.	
<b>Lead Lag Master Configuration ADVANCED — Drop Stage tab</b>						
<i>(Use scroll arrows to toggle between Central Heat, Domestic Hot Water, Mix, Frost Protection, Outdoor reset, Warm Weather Shutdown, Algorithms, Rate Allocation, Add Stage, Drop Stage and Modulation pages)</i>						
Method I		See description		Use error threshold	<ul style="list-style-type: none"> <li>Use error threshold to add stage or</li> <li>Do not add stage</li> </ul>	
Detection time I	hr mm ss	0h 0m 0s	0h 10m 0s	0h 0m 30s	Delay before dropping a stage once temperature has risen to setpoint plus the error threshold.	
Error threshold	°F or °C	2	20	10°F (6°C)	Temperature rise above setpoint required before more stages are dropped.	
Inter-stage delay	hr mm ss	0h 0m 0s	0h 10m 0s	0h 0m 15s	Minimum time after a stage is dropped before another stage can be dropped.	
Boiler off options		See description		All boilers off . .	<ul style="list-style-type: none"> <li>All boilers off at threshold (all boilers shut down at error threshold)</li> <li>Lead boiler off at threshold (only the lead boiler shuts down)</li> </ul>	
All boilers off threshold	°F or °C	70°F (21°C)	195°F (91°C)	195°F (91°C)	Temperature at which all boilers are turned off.	



# Sola control parameter table *(continued)*

HOME PAGE → → CONFIGURATION

**Figure 86** (continued) Sola CONFIGURATION VALUES — setup options — White text on black titles are configuration groups — see Figure 63, page 61 for location of configuration group in menus (**Enter changed values in the last column**)

Menu/Item	Units	Low Value	High Value	Default	Description	Changed to
<b>Lead Lag Master Configuration ADVANCED — Modulation tab</b>						
<i>(Use scroll arrows to toggle between Central Heat, Domestic Hot Water, Mix, Frost Protection, Outdoor reset, Warm Weather Shutdown, Algorithms, Rate Allocation, Add Stage, Drop Stage and Modulation pages)</i>						
Modulation backup sensor		See description		Disabled	<ul style="list-style-type: none"> <li>• Disabled</li> <li>• Lead boiler outlet sensor</li> <li>• Slave boiler outlet sensor average</li> </ul>	
Off hysteresis	°F or °C	2°F (1°C)	20°F (11°C)	10°F (6°C)	Temperature rise above setpoint where lead lag operation ends.	
On hysteresis	°F or °C	2°F (1°C)	20°F (11°C)	10°F (18°C)	Temperature drop below setpoint where lead lag operation starts.	
P gain		Not adjustable		50	Gain adjustment for proportional calculation of load response.	
I gain		Not adjustable		50	Gain adjustment for integral calculation of load response.	
D gain		Not adjustable		50	Gain adjustment for differential calculation of load response.	



# Startup — fill the system

## Clean system to remove sediment

**▲WARNING** You must thoroughly flush the system (without boiler connected) to remove sediment. The high-efficiency heat exchanger can be damaged by buildup or corrosion due to sediment.

- If necessary, use an approved chemical cleaning agent, following the manufacturer's guidelines for procedures.
  - A list of approved cleaning products is available at [www.Weil-McLain.com](http://www.Weil-McLain.com).
  - See Replacement parts at the end of this manual for Weil-McLain part numbers to obtain cleaning agents through a Weil-McLain distributor.
- For zoned systems, flush each zone separately through a purge valve.
  - If purge valves and isolation valves are not already installed, install them to properly clean the system.
- Flush the system until water runs clean and you are sure all piping is free of sediment.

**▲WARNING** Do not use petroleum-based cleaning or sealing compounds in the boiler system. Damage to elastomer seals and gaskets in the system could occur, resulting in substantial property damage.

Before filling the boiler and system with water, verify the water chemistry complies with these instructions.

**DO NOT fill with softened water.** Boiler corrosion can occur.

Failure to comply could result in boiler failure or unreliable operation.

**▲WARNING** Install a strainer or other mechanical separator device if necessary to ensure sediment will not enter the boiler.

## Water chemistry

### Water pH between 7.0 and 8.5

- Maintain boiler water pH between 7.0 and 8.5. Test the water with litmus paper or have it chemically analyzed by a water treatment company.
- If pH differs from above, consult a local water treatment company for treatment needed.
- DO NOT** use softened water. Softened water can cause corrosion.

### Hardness must be less than 7 grains

- Consult local water treatment companies for unusually hard water areas (above 7 grains hardness).

### Chlorine concentration must be LESS THAN 200 ppm

- Filling with chlorinated fresh water should be acceptable since drinking water chlorine levels are typically less than 5 ppm.
- Do not use the boiler to directly heat swimming pool or spa water.
- Do not fill boiler or operate with water containing chlorine in excess of 200 ppm.

## Antifreeze

**▲WARNING** Use only antifreeze listed by Weil-McLain as suitable for use with SlimFit Gas Boilers. See additional requirements in the antifreeze WARNING on the next page.

- A list of approved antifreeze products is available at [www.Weil-McLain.com](http://www.Weil-McLain.com).
- See Replacement parts at the end of this manual for Weil-McLain part numbers to obtain antifreeze through a Weil-McLain distributor.

### Use the correct amount of antifreeze

- Determine the **freezing temperature needed** (to protect against lowest likely temperature the system water will encounter).
- Find the **antifreeze percentage** (concentration by volume) needed for this temperature from the antifreeze manufacturer's data on the antifreeze container.

**▲WARNING** DO NOT exceed 50% by volume concentration of antifreeze.

- Calculate the **total volume** (gallons) of all system piping and components, including the expansion tank and boiler.
  - Boiler water content is listed on page 126.
  - Include the expansion tank water content.
- The gallons of antifreeze required equals the total water volume multiplied times the antifreeze percentage required.

## Fill and test water system

- Fill system only after ensuring the water meets the requirements of this manual.
- Close manual and automatic air vents and boiler drain valve.
- Fill to correct system pressure. Correct pressure will vary with each application.
  - Pressure will rise when boiler is turned on and system water temperature increases.
  - Operating pressure should be no higher than 80% of the relief valve setting for most systems.
- At initial fill and during boiler startup and testing, check the system thoroughly for any leaks. Repair all leaks before proceeding further.

**▲WARNING** Eliminate all system leaks. Continual fresh make-up water will reduce boiler life. Minerals can build up in sections, reducing heat transfer, overheating heat exchanger, and causing heat exchanger failure.

## Purge air from water system

- Connect a hose to the purge valve (see purge/drain valves shown in piping diagrams beginning on page 16). Route the hose to an area where water can drain and be seen.
- Close the boiler or system isolation valve between the purge valve and fill connection to the system.
- Close zone isolation valves.
- Open quick-fill valve on cold water make-up line.
- Open purge valve.



## Startup — fill the system *(continued)*

### **▲WARNING** FREEZE PROTECTION *(when used)*

Follow these guidelines to prevent possibility of severe personal injury, death or substantial property damage:

- **NEVER use automotive or standard glycol antifreeze, even glycol made for hydronic systems.** Use only freeze-prevention fluids recommended by Weil-McLain for application in SlimFit Boiler systems.
  - **Thoroughly flush any system that has used glycol** before installing the new SlimFit boiler.
  - **Review the material safety data sheet (MSDS)** for the fluid used with the boiler owner and leave a copy for reference. The MSDS contains information on potential hazards and first aid procedures for exposure or ingestion.
  - **Check antifreeze inhibitor level at least annually.** Glycol concentration and inhibitor levels may change over time. Add antifreeze to increase concentration if necessary. Add inhibitor as needed to bring to acceptable level, using inhibitor test kit to verify.
  - When using freeze protection fluid with automatic fill, **install a water meter to monitor water make-up.** Freeze protection fluid may leak before the water begins to leak, causing concentration to drop, reducing the freeze protection level.
  - **DO NOT exceed 50% antifreeze by volume.** Antifreeze moves more sluggishly than water and can interfere with heat transfer. At antifreeze concentrations higher than 50%, sludge can develop in the boiler, potentially causing damage to the heat exchanger.
  - **Clean the system before filling.** Always drain and flush the system thoroughly before filling with antifreeze. Sludge, iron oxide deposits and other sediment in the system inhibit flow and can cause rapid breakdown of inhibitors.
  - Use only antifreeze recommended by Weil-McLain.
6. One zone at a time, open the isolation valves. Allow water to run through the zone, pushing out the air. Run until no noticeable air flow is present. Close the zone isolation valves and proceed with the next zone. Follow this procedure until all zones are purged.
7. Close the quick-fill water valve and purge valve and remove the hose. Open all isolation valves. Watch that system pressure rises to correct cold-fill pressure.
8. After the system has operated for a while, eliminate any residual air by using the manual air vents located throughout the system.
9. If purge valves are not installed in system, open manual air vents in system one at a time, beginning with lowest floor. Close vent when water squirts out. Repeat with remaining vents.
10. Open automatic air vent (diaphragm-type or bladder-type expansion tank systems only) one turn.
11. Starting on the lowest floor, open air vents one at a time until water squirts out.
12. Repeat with remaining vents.
13. Refill to correct pressure.

**NOTICE** Weil-McLain provides information for application of the antifreeze products listed in this document only for use in Weil-McLain SlimFit boilers. Do not apply these products or instructions for other applications. Local codes may require a backflow preventer or actual disconnection from city water supply.

4. See separate instructions or Weil-McLain website for suggested guidelines to determine how much inhibitor to use.

### **Check/verify water chemistry**

1. The system may have residual substances that could affect water chemistry.
2. After the system has been filled and leak tested, verify water pH and chlorine concentrations are acceptable.
3. Verify antifreeze concentration, when used.
4. Follow the instructions on the Sentinel test kit to sample the system water and verify inhibitor concentration.

### **Check inhibitor and antifreeze concentrations annually**

1. Test the pH of a sample of system water at least annually.
  - a. The pH of the water mixture must be between 7.0 and 8.5.
  - b. Or use the Sentinel inhibitor test kit to check concentration.
2. If pH is outside this range (or inhibitor test kit indicates low level), the inhibitor level may not be sufficient to prevent corrosion.
3. Test antifreeze concentration.

**▲WARNING** Test antifreeze concentration at least annually. If concentration is low, add antifreeze or drain system and refill with correct mixture. Follow instructions on page 87 to determine amount of antifreeze needed.

4. Check inhibitor level after adjustments are made.

### **▲WARNING** X100 inhibitor must be used

1. The SlimFit boiler must have Sentinel X100 added to the system to prevent damage to the boilers' heat exchanger. See Replacement Parts section at the end of this manual for re-ordering information.
2. After filling the system as directed in these instructions, use a caulking gun to inject the X100 inhibitor concentrate into the system, or fill with the X100 in its liquid form, following the instructions on the tube or container.
3. After adding the inhibitor to the system, allow time for the water to circulate and mix. Then check the inhibitor level. Add additional inhibitor if necessary.





# Startup — final checks

## Check thermostat circuit(s)

1. Disconnect the two external wires connected to the boiler thermostat terminals (see instructions beginning on page 51 for terminal locations).
2. Connect a voltmeter across these two incoming wires. Close each thermostat, zone valve and relay in the external circuit one at a time and check the voltmeter reading across the incoming wires.

**▲WARNING** There should NEVER be a voltage reading. Applying voltage across the thermostat terminals will damage the Sola control. If a voltage does occur under any condition, check and correct the external wiring. (This is a common problem when using 3-wire zone valves.)

3. Once the external thermostat circuit wiring is checked and corrected if necessary, reconnect the external thermostat circuit wires. Allow the boiler to cycle.

## Inspect/fill condensate system

### Inspect/check condensate lines and fittings

1. Inspect the condensate drain line and condensate trap. (See page 48 for component locations.)

### Fill condensate trap with water

1. Fill the condensate trap with fresh water, either by removing, filling and re-installing or by pouring water into the inspection caps near the flue connection (piping end of boiler).
2. **To remove the trap**, see page 48 for information.
  - a. Loosen the two stainless steel hose clamps on the flexible coupling
  - b. Slide the flexible coupling over the 1" PVC pipe connected to the trap.
  - c. Loosen the condensate trap inlet connection.
  - d. Remove condensate trap and flush as needed.

**▲WARNING** The condensate trap must be filled with water during all times of boiler operation to avoid flue gas emission from the condensate drain line. Failure to fill the trap could result in severe personal injury or death.

## Inspect pressure switch hoses

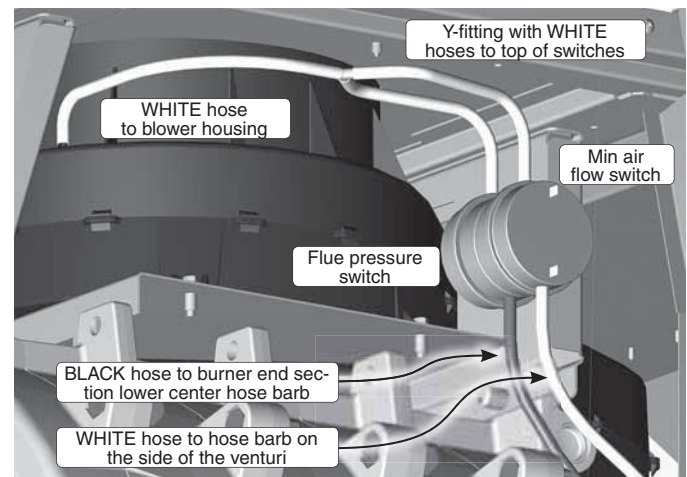
**▲WARNING** The pressure switch sense lines must be in good condition and firmly attached to the correct locations. Incorrect placement or disconnected sense lines can result in unreliable boiler operation.

1. Inspect all pressure switch sense hoses and verify that they are correctly installed (Figure 87). Replace if necessary.
2. Inspect and verify attachment of the plastic gas valve/venturi reference line (Figure 96, page 100). Replace if necessary.

## Final checks before starting boiler

- Read the instructions to adjust and set up the Sola module. Verify that all settings have been made correctly.

Figure 87 Pressure switches



**▲WARNING** For altitudes above 5,500 feet, **the Sola control must be set to the proper Lightoff rate**. Follow instructions on page 90. Failure to correctly set the speed could result in unreliable operation.

- Verify that the boiler and system are full of water and all system components are correctly set for operation.
- Vent any remaining air from system using manual vents. Air in the system will interfere with circulation and cause heat distribution problems and noise.
- Check system piping for leaks. If found, shut down boiler and repair immediately.

**▲WARNING** **Eliminate all system leaks.** Continual fresh make-up water will reduce boiler life. Minerals can build up in sections, reducing heat transfer, overheating heat exchanger, and causing heat exchanger failure.

- Fill condensate trap with water (see above for procedure).
- Verify electrical connections are correct and securely attached.
- Inspect vent piping and air piping (direct vent systems) for signs of deterioration from corrosion, physical damage or sagging. Verify vent piping and air piping are intact and correctly installed per this manual.

**▲WARNING** Venting system must be sealed gas-tight to prevent flue gas spillage and carbon monoxide emissions which will result in severe personal injury or death.


**▲WARNING** Before starting the boiler, and during initial operation, use a leak detector or smell near the floor and around the boiler for gas odorant or any unusual odor. Remove boiler access door and smell interior of boiler enclosure. Do not proceed with startup if there is any indication of a gas leak. Repair any leak at once.

If you discover evidence of any gas leak during operation, shut down the boiler at once. Find the leak source with bubble test and repair immediately. Do not start boiler again until corrected. Failure to comply could result in severe personal injury, death or substantial property damage.



# Startup procedure

## Figure 88 To manually set firing rate for testing:


On the Sola display, navigate to HOME PAGE →  → DIAGNOSTICS → DIAGNOSTICS TESTS → MODULATION TEST.

- This will open the Modulation Test window (Figure 72, page 64).
- Press MAXIMUM MODULATION, then press START TEST to force the boiler to high fire rate. Press STOP TEST to end the test.
- Press MINIMUM MODULATION, then press START TEST to force the boiler to low fire rate. Press STOP TEST to end the test.

**⚠ WARNING** You must log in with the contractor password before testing or making adjustments to Sola parameters. See Contractor log-in on page 60 for the procedure.

## Set/verify blower speed settings

### High fire and low fire speed settings


1. On the Sola display, navigate to HOME PAGE →  → CONFIGURE → MODULATION CONFIGURATION.
2. Press the padlock icon (upper right corner) to log in.
3. Check the CH and DHW Maximum Modulate rates and the Minimum Modulation rate on the display.
4. If the rates do not coincide with Figure 89, change the values:
  - a. Use high altitude values if the installation is above 5,500 feet.
  - b. Maximum rates for CH and DHW must be at or below the value shown in Figure 89.
  - c. Minimum rate must be at or above the value shown in Figure 89.

**Figure 89** Blower speed — required settings (High altitude means installations above 5,500 feet)

Boiler	Low fire		Ignition		High fire	
	Factory setting	High altitude	Factory setting	High altitude	Factory setting	Maximum setting
<b>SF1000</b>	1300	1600	2200	2900	5200	5200
<b>SF1500</b>	1200	1500	2300	3000	5100	5100
<b>SF2000</b>	1025	1325	1600	2100	4500	4500

### Ignition speed setting

**⚠ WARNING** The ignition (lightoff) blower speed must be set to the value given in Figure 89. Incorrect ignition speed can result in unreliable operation of the boiler, causing possible loss of heat.

1. On the Sola display, navigate to HOME PAGE →  → BURNER CONTROL TIMINGS & RATES.
2. Check the value shown on the display for Lightoff rate. This value must agree with that in Figure 89. (High altitude values apply for installations over 5,500 feet.)

3. If the rate on the display is correct, proceed to start.
4. If the rate must be changed, press the Lightoff rate line.
  - a. A Warning will appear. Read and acknowledge the warning.
  - b. Press the Return arrow (upper right corner of screen) to return to the Configure menu.
  - c. Press the VERIFY button at the bottom right of the screen.
  - d. Press BEGIN to start the verification process.
  - e. Read the values shown on the screen. If the values are correct, press YES.
  - f. Follow the screen prompt to press the Sola reset button (on top of boiler).
  - g. The screen will show VERIFICATION FINISHED.


## To start the boiler

1. Turn OFF the boiler ON/OFF switch.
2. Read and follow the Operating Instructions, Figure 92, page 93.
3. The Sola control will initialize and follow its sequence of operation (see page 58).

## If boiler does not start correctly

1. Check for loose connections, blown fuse or service switch off?
2. Is external limit control (if used) open? Is boiler water temperature above 200 °F?
3. Is thermostat set below room temperature?
4. Is gas turned on at meter or boiler?
5. Is incoming gas pressure greater or less than required on page 49?
6. Are parameters set correctly as per this manual?
7. Is the warm weather shutdown activated?
8. If none of the above corrects the problem, refer to Troubleshooting, beginning on page 103.

## Check combustion using instruments

1. Initiate a call for heat on one of the inputs.
2. Remove the cap from the flue sample port on the rear of the boiler flue connection. Insert a flue gas sample probe. 
3. Force the boiler to **high fire** (see Figure 88).
4. Look at the flame through the flame inspection window. The high fire flame should be blue and should be stable. The burner surface should be covered with orange dots.
5. Test for CO<sub>2</sub> (or O<sub>2</sub>) and for CO. The CO<sub>2</sub> values must be within the range allowed in Figure 90.
  - a. If results are acceptable, press STOP TEST and proceed to step 1.
  - b. If results are NOT acceptable, follow the instructions under “Gas valve adjustment procedure” to set the CO<sub>2</sub> values.
6. Force the boiler to **low fire** (see Figure 88).
7. Look at the flame through the flame inspection window. The low fire flame should be stable and evenly distributed over burner surface with a uniform orange color.
8. Perform the combustion test described above.



## Startup procedure *(continued)*

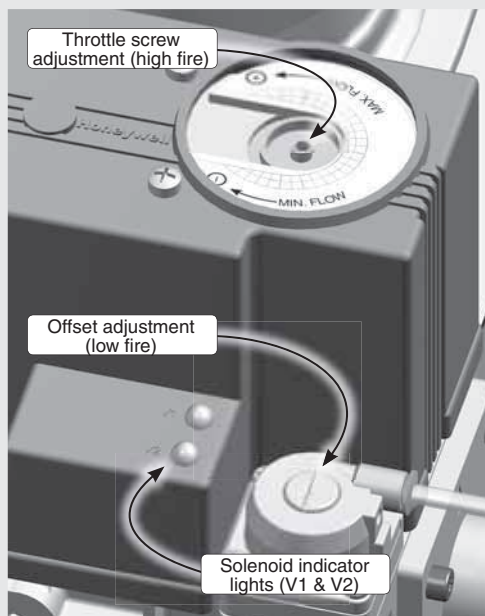
### ⚠ WARNING

If combustion at either high or low fire is outside the range given in Figure 90, follow the procedure given for adjusting the throttle screw on the gas valve. If throttle screw adjustment does not correct the problem, then shut down the boiler and contact your local Weil-McLain representative. Throttle screw adjustment must be done only by a qualified technician, using calibrated test instruments. Failure to comply could result in severe personal injury, death or substantial property damage.

**Figure 90** Acceptable CO<sub>2</sub> and CO values

Boiler	High fire		Low fire	
	%CO <sub>2</sub> Note 1	CO ppm	%CO <sub>2</sub> Note 2	CO ppm
SF1000	9.00	< 60	8.75	< 60
SF1500	9.00	< 60	8.75	< 60
SF2000	9.00	< 60	8.75	< 60
Note 1	The high fire CO <sub>2</sub> listed is typical. The value may vary with conditions, but must not be lower than 8.5% nor higher than 10.0%.			
Note 2	The low fire CO <sub>2</sub> listed is typical. The value may vary with conditions, but must not be higher than the high fire CO <sub>2</sub> nor more than 0.5% less than the high fire CO <sub>2</sub> .			

**Figure 91** Gas valve adjustment locations *(ONLY for use by a qualified technician, using calibrated combustion test instruments)*



### ⚠ WARNING

You must re-install the flue gas sample port cover to prevent flue gas spillage into the boiler room. Failure to comply could result in severe personal injury, death or substantial property damage.

## Gas valve adjustment procedure

### ⚠ WARNING

**DO NOT** attempt to adjust the gas valve settings unless you are a qualified technician, and with the use of calibrated combustion test instruments. Follow instructions in this section.

### ⚠ WARNING

**DO NOT adjust or attempt to measure gas valve outlet pressure.** The gas valve is factory-set for the correct outlet pressure, requiring no field adjustment. Attempting to alter or measure the gas valve outlet pressure could result in damage to the valve, causing potential severe personal injury, death or substantial property damage.

1. **This procedure is only necessary when combustion tests indicate the need.**
2. Boiler behavior that might indicate a need to check combustion values at high fire (as per page 90) to verify boiler is in adjustment include: difficulty igniting, poor flame stability at low fire, combustion noise or high carbon monoxide values.
3. Combustion readings must be taken at both high fire and low fire.

### Adjust valve at high fire

1. Manually set the boiler to high fire (see Figure 88). Perform combustion test as described at left.
  - a. Remove the blue cover on the throttle screw opening with a straight-bit screwdriver.

### NOTICE

For the following, make only small (1/8-turn) throttle screw adjustments. Adjustment can be sensitive. Use a 3-mm hex wrench.

- b. If the CO<sub>2</sub> is HIGH, turn the throttle screw **CLOCKWISE** to lower the input. Allow the boiler to stabilize and take another reading. Continue until the desired CO<sub>2</sub> value is achieved.
- c. If the CO<sub>2</sub> is LOW, turn the throttle screw **COUNTER-CLOCKWISE** to increase the input. Allow the boiler to stabilize and take another reading. Continue until the desired CO<sub>2</sub> value is achieved.
- d. Re-install the blue cover on the gas valve.

### Adjust valve at low fire

1. Manually set the boiler to low fire (see Figure 88). Perform combustion test as described at left.
2. If results are acceptable at low fire, verify high fire readings again and restore the boiler to automatic operation.
3. If combustion results are not acceptable, remove the cover screw over the offset adjustment (see Figure 91).
  - a. Use a T40 Torx driver to adjust the setting. Rotate clockwise to increase CO<sub>2</sub>, rotate counterclockwise to decrease CO<sub>2</sub>. Re-install the cover screw when completed.
  - b. After making an adjustment, go back to check high fire. If the adjustment on low fire is large enough it can impact the high fire setting. The process may need to be repeated.
4. Consult your local Weil-McLain representative if acceptable results cannot be obtained for both high and low fire.



## Startup procedure *(continued)*

### Adjust and test boiler controls

- Follow instructions in this manual to set and verify operation of the boiler controls.
- Test the gas pressure switches. Then restore the settings to the following:
  - High gas pressure switch — 14" w.c.
  - Low gas pressure switch — 2" w.c.
  - Make sure gas pressure complies with instructions on page 49.

### Gas valve leakage testing

**▲WARNING** DO NOT connect a manometer to the manual gas valve or the automatic gas valve. The high vacuum from the blower could pull fluid into the gas line, possibly damaging the gas valves.

- Refer to the gas valve manufacturer's instructions for the procedure to test the valve. Use the procedure below to turn the gas valve's two solenoid valves on one at a time.

### Operating gas valves solenoids for leak testing

- Turn off power to the boiler.
- Obtain the gas valve test harness, located in the envelope assembly.
- Disconnect the gas valve electrical harness
- Plug in the gas valve test harness between the gas valve and the gas valve electrical harness.
- Ensure both test harness rocker switches are in the ON position.
- Turn on power to the boiler.
- Give the boiler a call for heat.
- Verify that the boiler operates through a normal ignition sequence.
- To operate each of the gas valve's solenoids individually:
  - Turn the test harness rocker switches to OFF.
  - Turn on one of the rocker switches.
  - Provide a call for heat.
  - When the gas valve is energized, you should only see one indicator light on, V1 or V2 (Figure 91).
  - Use a piece of tape to label this rocker switch as V1 or V2, depending on which light was turned on.
  - Label the other rocker switch with the name of the other indicator light (V1 or V2).
  - Power the boiler on and off and use the rocker switches to operate solenoid V1 or V2 independently as called for in the gas valve manufacturer's leak test instructions.
- Once testing is complete, turn power off to boiler.



**▲WARNING** Disconnect the gas valve test harness and place back in the envelope assembly for future use. Reconnect gas valve electrical harness.

- Turn power back on to boiler.
- Operate the boiler through an ignition cycle to ensure proper operation.

### Check gas input rate

- Measure natural gas input:
  - Operate boiler 10 minutes.
  - Turn off other appliances.
  - At natural gas meter, measure time (in seconds) required to use one cubic foot of gas.
  - Calculate gas input:

$$\frac{3600 \times 1000}{\text{number of seconds from step c}} = \text{Btuh}$$

- Btuh calculated should approximate input rating on boiler rating label.

### Verification check list

- Verified that the Sola control is programmed correctly?
- Verified that boiler and heat distribution units filled with water?
- Verified water chemistry per page 87?
- Automatic air vents, if used, opened one full turn?
- Air purged from system?
- Air purged from gas piping? Piping checked for leaks?
- Filled condensate trap with water?
- Thermostat circuit wiring checked to ensure there are no stray voltages?
- Followed Operating Instructions, Figure 92, page 93
- Burner flame and combustion verified per page 90?
- Verified control operation for space heating and DHW (if used) per this manual?
- Tested additional field-installed controls? Verified controls cause automatic reset or manual reset lockout as desired.
- Set additional field-installed limit control(s) to system temperature requirements?
- Adjusted balancing valves and controls to provide design temperature to system?
- For multiple zones, adjusted for correct flow in each zone?
- Verified thermostat heat anticipator (if available) set properly (see page 55 for requirements)?
- Cycled boiler with thermostat (and with DHW aquastat, if installed) — Raised to highest setting and verified boiler goes through normal startup cycle? Lowered to lowest setting and verified boiler goes off?
- Measured natural gas input?
- Checked incoming gas pressure as specified on page 49.
- Observed several operating cycles for proper operation.
- Set room thermostat to desired room temperature (and DHW aquastat, if installed, to desired DHW storage temperature)?
- Reviewed all instructions shipped with this boiler with owner or maintenance person?
- Filled in **Installation certificate** on page 128?
- Filled out the warranty registration card and send to Weil-McLain?

**▲WARNING** Return instructions to envelope and give to owner or place inside boiler housing. Instructions must be available for all service and adjustment of the boiler.



## Startup procedure *(continued)*

Figure 92 Operating instructions (WARNING — Verify that the Sola is set correctly before proceeding.)

FOR YOUR SAFETY  
READ BEFORE OPERATING

⚠ WARNING

If you do not follow these instructions exactly, a fire or explosion may result causing property damage, personal injury or loss of life.

A. This appliance does not have a pilot. It is equipped with an ignition device which automatically lights the burner. Do not try to light the burner by hand.

B. Before OPERATING, smell all around the appliance area for gas. Be sure to smell next to the floor because some gas is heavier than air and will settle on the floor. See below.

C. Use only your hand to turn the gas valve handle. Never use tools. If the handle will not turn by hand, don't try to repair it, call a qualified service technician. Force or attempted repair may result in a fire or explosion.

D. Do not use this appliance if any part has been under water. Immediately call a qualified service technician to inspect the appliance and to replace any part of the control system and any gas control, which has been under water.

WHAT TO DO IF YOU SMELL GAS


- Do not try to light any appliance.
- Do not touch any electric switch; do not use any phone in your building.

- Immediately call your gas supplier from a neighbor's phone. Follow the gas supplier's instructions.
- If you cannot reach your gas supplier, call the fire department.


OPERATING INSTRUCTIONS



1. Stop! Read the safety information at left on this label. This appliance is equipped with an ignition device which automatically lights the burner. Do not try to light the burner by hand.
2. Set room thermostat(s) to lowest setting. Verify external manual gas cock is open (valve handle parallel to gas piping).
3. Turn OFF all electrical power to the appliance.
4. Remove boiler access door by lifting up.
5. Turn boiler manual gas valve handle counterclockwise ↺ to open gas supply.
6. Wait five (5) minutes to clear out any gas. Then smell for gas, including near the floor. If you smell gas, STOP! Follow "B" in the safety information to the left. If you don't smell gas, go to the next step.
7. Turn ON all electrical power to the appliance.
8. Set thermostat(s) to desired setting.
9. The display will show symbols and text describing the status of the boiler as it proceeds through its operating sequence.
10. If the appliance will not operate when there is a call for heat and piping is not hot, follow the instructions "To Turn Off Gas To Appliance" below and call your service technician or gas supplier.

**Gas valve  
CLOSED**



**Gas valve  
OPEN**



11. Replace jacket front panel. Make sure panel is seated firmly in place.

TO TURN OFF GAS TO THE APPLIANCE

1. Set room thermostats to lowest setting.
2. Turn OFF all electrical power to the appliance.

3. Close external manual gas cock (valve handle perpendicular to gas piping). Remove boiler access door. Turn boiler manual gas valve handle clockwise ↻ to close gas supply.
4. Replace boiler access door.

550-101-262 (0213)



# Sola Information and Operations screens

**WARNING**

**DO NOT OPERATE THIS BOILER** without following all instructions and procedures specified in the following sections:

- Startup — fill the system (page 87)
- Startup — final checks (page 89)
- Startup procedure (page 90).

Failure to follow the instructions in this manual could result in severe personal injury, death or substantial property damage.

**Use the Information screen (below) and Operation screen (see next page) to monitor and manually operate the boiler.**



Press the boiler icon on the home page to go to the information screen.

**Boiler 1**

Demand and burner status

Demand OFF      Firing rate 0 RPM  
 Burner state Standby      Fan speed 0 RPM

Temperatures, analog input and flame signal

Setpoint

Inlet	Outlet	Stack	Lead Lag	4-20mA	Outdoor	Flame
69°F	147°F	180°F	69°F	LOCAL	69°F	0.00V

Operating conditions (toggle between Pumps, Setpoints and Modulation)

Setpoints	ON	Modulation	OFF	Pumps
Central Heat	95°F	100°F	105°F	OUTDOOR
Domestic Hot Water	185°F	190°F	195°F	OUTDOOR
Lead Lag	64°F	84°F	94°F	OUTDOOR

History

Configure      Operation      Diagnostics      Details

See instructions beginning on page 62.

See next page for overview.

See instructions beginning on page 63.

See instructions beginning on page 64. (under Trend analysis)

See instructions beginning on page 62.

- Three information screens (left column) are available:
- Setpoints (shows current setpoints for CH, DHW and Lead/lag)
  - Pumps (shows status of pumps)
  - Modulation (shows modulation conditions)

Use the button labeled Pumps, Modulate or Setpoint to toggle between the views.



# Sola Information and Operations screens (continued)

Figure 93 Sola display information and operation screen navigation



Press the boiler icon on the home page to go to the information screen.



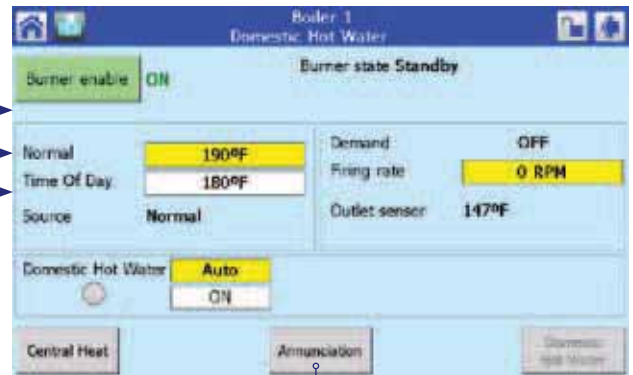
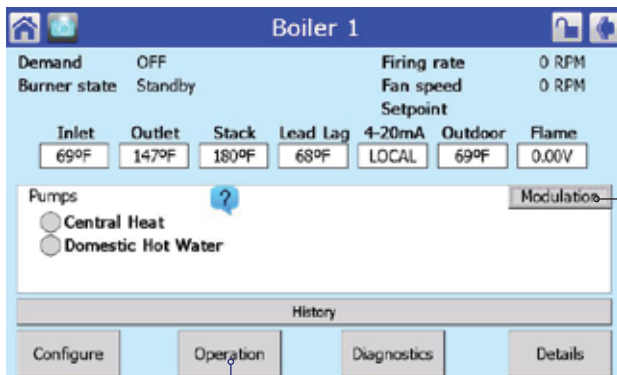
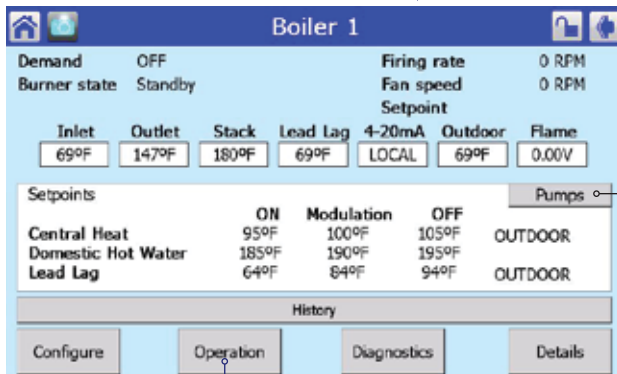
**WARNING** Make sure to return the boiler to automatic operation after using the operation screen for manual operation. Failure to do so could cause loss of heating.

Use the **Operation** screen (below) to

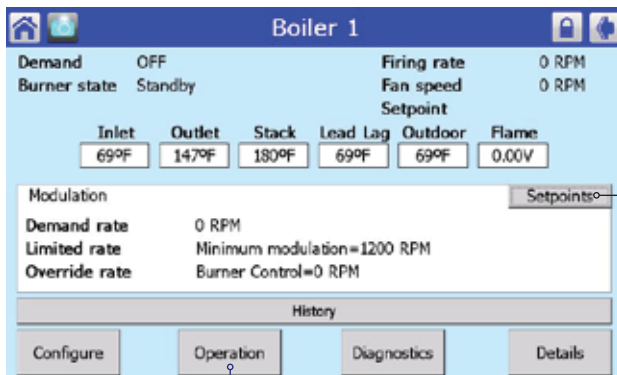
- manually activate central heating or DHW.
- manually set the firing rate
- enable/disable the burner
- change normal and time of day setpoints for CH

**Firing rate box** (rate side of screen) — Use to manually set the blower speed. When the box is pressed, a blower speed screen opens, and allows:

- numerically entering the firing rate.
- selecting manual or automatic operation of firing rate:
  - a. Automatic allows the Sola control to set blower speed (firing rate).
  - b. Manual in run sets the blower speed to the value set on the right of the screen during burner run periods.
  - c. Manual in run and standby sets the blower to the speed entered on the right side of the screen both during burner run and standby.



The Annunciation screen shows the status of input and interlock circuits (ON or OFF).





# Annual startup and maintenance schedule

Figure 94 Service and maintenance schedules

<b>Service technician</b>		<b>Owner maintenance</b>	
<i>(see following pages for instructions)</i>		<i>(see SlimFit User's Information Manual for instructions)</i>	
ANNUAL STARTUP (See First-year special inspection)	<b>General:</b>	Daily	<ul style="list-style-type: none"> <li>Check boiler area.</li> <li>Check air openings.</li> <li>Check pressure/temperature gauge.</li> </ul>
	Investigate reported problems. Inspect air inlet box screen; clean and vacuum if necessary; WARNING — no solvents. Clean base collector and condensate trap and fill with fresh water. Check for leaks (water, gas, flue, condensate). Check system water chemistry, inhibitor level and antifreeze concentration, if used. Check boiler relief valve. Verify flue and air lines in good condition and sealed tight. Check system water pressure/system piping/expansion tank. Ignition electrode and flame sense rods (inspect, clean and check spacings). Ignition and ground wiring. Check control function/settings: <ul style="list-style-type: none"> <li>High gas pressure switch</li> <li>Low gas pressure switch</li> <li>Low water cut off</li> </ul> Wiring and connections. Perform startup checkout and performance verification beginning with Startup — fill the system, page 87. Flame inspection (stable, uniform). Flame signal. Clean heat exchanger if flue temp is more than 30°F above return water temp. Check blower speed settings.	Monthly	<ul style="list-style-type: none"> <li>Check vent piping.</li> <li>Check air piping.</li> <li>Check relief valve.</li> <li>Check condensate drain system.</li> <li>Check automatic air vents (if used).</li> </ul>
	<b>Additional if combustion or performance indicate need:</b>	Periodically	<ul style="list-style-type: none"> <li>Test low water cutoff by pressing test button.</li> </ul>
	Clean heat exchanger. Remove and clean burner using compressed air only. Vacuum the blower.	Every 6 months	<ul style="list-style-type: none"> <li>Check boiler piping (gas and water).</li> <li>Operate relief valve.</li> </ul>
	<b>Review:</b> Review with owner.	End of season	<ul style="list-style-type: none"> <li>Shut boiler down (unless boiler used for domestic water).</li> </ul>

**WARNING** Follow the service and maintenance procedures given throughout this manual and in component literature shipped with the boiler. Failure to perform the service and maintenance could result in damage to the boiler or system. Failure to follow the directions in this manual and component literature could result in severe personal injury, death or substantial property damage.





# Annual startup

## HANDLING CERAMIC FIBER MATERIALS

### REMOVAL OF SIGHT GLASS GASKET



The sight glass gasket in this product contains ceramic fiber material. Ceramic fibers can be converted to cristobalite in very high temperature applications. The International Agency for Research on Cancer (IARC) has concluded, “Crystalline silica inhaled in the form of quartz or cristobalite from occupational sources is carcinogenic to humans (Group 1).”:

- Avoid breathing dust and contact with skin and eyes.
  - Use NIOSH certified dust respirator (N95). This type of respirator is based on the OSHA requirements for cristobalite at the time this document was written. Other types of respirators may be needed depending on the job site conditions. Current NIOSH recommendations can be found on the NIOSH web site at <http://www.cdc.gov/niosh/homepage.html>. NIOSH approved respirators, manufacturers, and phone numbers are also listed on this web site.
  - Wear long-sleeved, loose fitting clothing, gloves, and eye protection.
- Apply enough water to the sight glass gasket to prevent airborne dust.
- Remove sight glass gasket from the boiler and place it in a plastic bag for disposal.
- Wash potentially contaminated clothes separately from other clothing. Rinse clothes washer thoroughly.

### NIOSH stated First Aid

- Eye: Irrigate immediately
- Breathing: Fresh air.

## FIRST-YEAR SPECIAL INSPECTION

1. **No later than 12 months** after the boiler is installed, obtain an Annual Maintenance kit and perform a first-year inspection of the boiler. This must include the following **in addition to annual maintenance and startup procedures**.
  - a. Remove the heat exchanger cleanout plate. Inspect the heat exchanger and clean if necessary. See instructions for removing and replacing the heat exchanger cleanout plate, and for cleaning the heat exchanger, in the Maintenance section of this manual.
  - b. Make sure the burner is clean.
  - c. Make sure the burner gasket is in good condition. Replace if necessary.
  - d. Disconnect condensate trap and drain lines. Inspect, then flush thoroughly.
2. Determine follow-up maintenance and service needs based on the condition of the heat exchanger and condensate lines.
  - a. If the heat exchanger shows substantial fouling, or if condensate lines show accumulation of sediment, schedule a follow-up service call to perform the annual inspection again, sooner than the normal twelve months between.
  - b. Heavy fouling of the exchanger or condensate lines indicates possible combustion air contamination. Inspect the air intake area carefully, and remove possible contaminants. See “Corrosive contaminants and sources,” Figure 26, page 29, for products to avoid.



You must eliminate causes of corrosion and contamination to ensure reliable operation of the boiler and system.



## Annual startup *(continued)*

**⚠ WARNING** The boiler should be inspected and started annually, at the beginning of the heating season, only by a qualified service technician. In addition, the maintenance and care of the boiler designated in Figure 94, page 96 and explained on the following pages must be performed to assure maximum boiler efficiency and reliability. Failure to service and maintain the boiler and system could result in equipment failure.

**⚠ WARNING** Electrical shock hazard — Turn off power to the boiler before any service operation on the boiler except as noted otherwise in this instruction manual. Failure to turn off electrical power could result in electrical shock, causing severe personal injury or death.

**⚠ WARNING** Do not use solvents to clean any of the boiler components. The components could be damaged, resulting in unreliable or unsafe operation.

### Address reported problems

1. Inspect any problems reported by owner and correct before proceeding.

### Inspect boiler area

1. Verify that boiler area is free of any combustible materials, gasoline and other flammable vapors and liquids.
2. Verify that air intake area is free of any of the contaminants listed on page 29 of this manual. If any of these are present in the boiler intake air vicinity, they must be removed. If they cannot be removed, reinstall the air and vent lines per this manual and the SlimFit Boiler Vent Supplement.

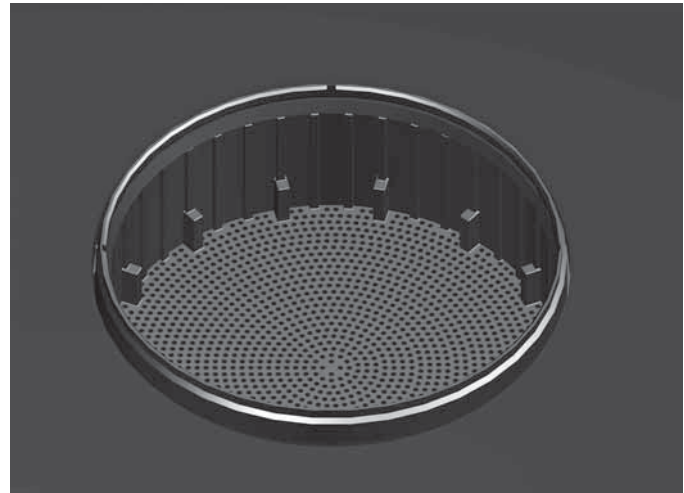
### Inspect air inlet box screen

1. Direct vent installations — Remove the cover from the air pipe connection inspection tee (in installed) or remove air piping as necessary to access the inlet box.
2. If unable to look directly down into the air inlet box (Figure 95), use an inspection mirror.
3. Thoroughly inspect the air inlet screen.
4. If debris has collected on the air inlet screen, use a vacuum to remove accumulation. Brush with a soft brush if necessary to loosen material.
5. Direct vent installations — Re-install the cover on the air pipe connection tee when complete.
6. Direct Exhaust installations – Inspect and clean screen as needed.

### Clean the condensate trap

1. Inspect the condensate trap. If the reservoir or trap portion has debris accumulated, remove the trap and clean.

**Figure 95** Air inlet box screen



2. To remove, see page 48 for information.
3. Loosen the two stainless steel hose clamps on the flexible coupling
4. Slide the flexible coupling over the 1" PVC pipe connected to the trap.
5. Loosen the condensate trap inlet connection.
6. Remove condensate trap and flush as needed.
7. Fill condensate trap with fresh water before re-installing or re-install the trap and fill using the inspection caps near the flue connection (piping end of boiler).
8. Ensure the condensate line gasket is in place. Then tighten the condensate trap inlet connection clamp nut securely by hand.
9. Slide the flexible coupling back into place, connecting the condensate trap and the condensate drain piping.
10. Tighten the stainless steel hose clamps to secure the flexible coupling in place.
11. Verify that all the connections are made with no leaks to complete installation.

### Check all piping for leaks

**⚠ WARNING** Eliminate all system or boiler leaks. Continual fresh make-up water will reduce boiler life. Minerals can build up in sections, reducing heat transfer, overheating heat exchanger, and causing heat exchanger failure. Leaking water may also cause severe property damage.

1. Inspect all water and gas piping and verify to be leak free.
2. Look for signs of leaking lines and correct any problems found.
3. Check gas line using procedure on page 49.

### Check air openings

1. Verify that combustion and ventilation air openings to the boiler room and/or building are open and unobstructed. Check operation and wiring of automatic combustion air dampers, if used.



## Annual startup *(continued)*

2. Verify that boiler vent discharge and air intake are clean and free of obstructions.

### Flue vent system and combustion air piping

1. Visually inspect entire flue gas venting system (and air piping, if installed) for blockage, deterioration or leakage. Repair any joints that show signs of leakage in accordance with vent manufacturer's instructions. When air is ducted to boiler, verify that air inlet pipe is connected and properly sealed.

**▲WARNING** Failure to inspect for the above conditions and have them repaired can result in severe personal injury or death.

### Check water system

1. Verify all system components are correctly installed and operational.
2. Check the cold fill pressure for the system. Verify it is correct (usually around 12 psig).
3. Watch the system pressure as the boiler heats up (during testing) to ensure pressure doesn't rise too high. Excessive pressure rise indicates expansion tank sizing or performance problem.
4. Inspect automatic air vents and air separators. Remove air vent caps and briefly press push valve to flush vent. Reinstall caps. Make sure vents do not leak. Replace any leaking vents.
5. Check system water chemistry (inhibitor concentration, pH and hardness). See page 87.

### Check boiler relief valve

1. Inspect the relief valve and lift the lever to verify flow as in the following warnings, excerpted from a relief valve manufacturer's warning label. Before operating any relief valve, ensure that it is piped with its discharge in a safe area to avoid severe scald potential. Read manual section 3, page 12, before proceeding further.
2. If the relief valve weeps or will not seat properly, replace the relief valve. Ensure that the reason for relief valve weeping is the valve and not over-pressurization of the system due to expansion tank waterlogging or under-sizing.

**▲WARNING** Safety relief valves should be reinspected AT LEAST ONCE EVERY THREE YEARS, by a licensed plumbing contractor or authorized inspection agency, to ensure that the product has not been affected by corrosive water conditions and to ensure that the valve and discharge line have not been altered or tampered with illegally. Certain naturally occurring conditions may corrode the valve or its components over time, rendering the valve inoperative. Such conditions are not detectable unless the valve and its components are physically removed and inspected. This inspection must only be conducted by a plumbing contractor or authorized inspection agency — not by the owner. Failure to reinspect the boiler relief valve as directed could result in unsafe pressure buildup, which can result in severe personal injury, death or substantial property damage.

**▲WARNING**

Following installation, the valve lever must be operated AT LEAST ONCE A YEAR to ensure that waterways are clear. Certain naturally occurring mineral deposits may adhere to the valve, rendering it inoperative. When manually operating the lever, water will discharge and precautions must be taken to avoid contact with hot water and to avoid water damage. Before operating lever, check to see that a discharge line is connected to this valve directing the flow of hot water from the valve to a proper place of disposal. Otherwise severe personal injury may result. If no water flows, valve is inoperative. Shut down boiler until a new relief valve has been installed.

### Check expansion tank

1. Expansion tanks provide space for water to move in and out as the heating system water expands due to temperature increase or contracts as the water cools. Tanks may be open, closed or diaphragm or bladder type. See section 3 of this manual for suggested best location of expansion tanks and air eliminators.
  - Open-type — located above highest radiator or baseboard unit, usually in the attic or closet. Has a gauge glass and overflow pipe to a drain.
  - Closed-type — welded gas tight and located above boiler. Tank is partially filled with water, leaving an air cushion for expansion.
    - Make sure this type of tank is fitted with a tank fitting, such as the B & G Tank-Trol or Taco Taco-Trol. This fitting reduces gravity circulation of air-saturated tank water back to the system and prevents the air from bubbling up through the water as it returns from the system.
    - Do not use automatic air vents in systems with closed-type tanks. The air will escape from the system instead of returning to the tank. Eventually, the tank will waterlog and no longer control pressurization. The boiler relief valve will weep frequently.
  - Diaphragm- or bladder-type — welded gas tight with a rubber membrane to separate the tank pressurizing air and the water. May be located at any point in the system, but most often found near the boiler.
    - Systems with this type of expansion tank require at least one automatic air vent, preferably located on top of an air eliminator, as shown in examples in this manual.
2. If relief valve has tended to weep frequently, the expansion tank may be waterlogged or undersized.
  - **Closed-type tank** — tank is most likely waterlogged. Install a tank fitting if not already installed. Then check fill level per fitting manufacturer's instructions. If fill level is correct, check tank size against manufacturer's instructions. Replace with a larger tank if necessary.
  - **Diaphragm- or bladder-type** — first, check tank size to be sure it is large enough for the system. If size is too small, add additional tank (or tanks) as necessary to provide sufficient expansion. If tank size is large enough, remove tank from system and check charge pressure (usually 12 psig for residential applications). If tank won't hold pressure, membrane has been damaged. Replace tank.

## Annual startup *(continued)*

### Inspect ignition electrode

1. Remove the ignition electrode from the boiler heat exchanger burner end section. See image at right. Ignition electrode is longer than the flame sensor (see below) and has a brown ceramic insulator.
2. Remove any white oxides accumulated on the ignition electrode using steel wool. If the ignition electrode cannot be cleaned satisfactorily, replace ignitor with a new one.
3. Reinstall ignition electrode, making sure gasket is in good condition and correctly positioned.
4. Replace gasket if necessary.
5. Make sure the ignition electrode ground wire is under the top screw that secures the ignitor to the casting.



**WARNING** The ignition electrode must be installed on the burner end section. The flame sensor must be installed on the piping end section. Installing these components in the wrong locations could cause poor ignitions and lockout, resulting in loss of heat.

### Check ignition wiring

1. Check ignition cable electrical resistance. A good cable will have resistance between 900 and 1000 ohms. Replace if not acceptable.
2. Inspect boiler ground wire from ignition electrode to ground terminal strip.
3. Verify all wiring is in good condition and securely attached.
4. Check ground continuity of wiring using continuity meter.
5. Replace ground wires if results are not satisfactory.

### Inspect flame sense assembly

1. Remove the flame sensor assembly from the boiler heat exchanger piping end section. See image at right. Flame sensor insertion length is shorter than the ignition electrode (see above) and has a pink ceramic insulator.
2. Remove any white oxides accumulated on the flame sense rods using steel wool. If the flame sense rods cannot be cleaned satisfactorily, replace flame sense assembly with a new one.
3. Reinstall flame sense assembly, making sure gasket is in good condition and correctly positioned.
4. Replace gasket if necessary.
5. Inspect the flame sense harness and connections. Replace if necessary. See WARNING above about flame sensor location.



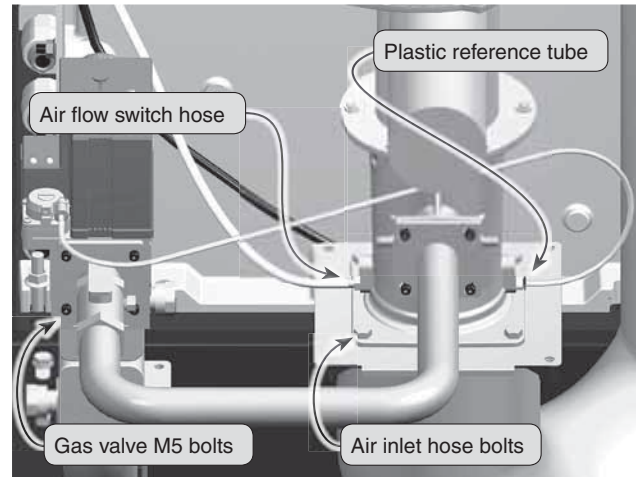
### Check all boiler wiring

1. Inspect all boiler wiring, making sure wires are in good condition and securely attached.

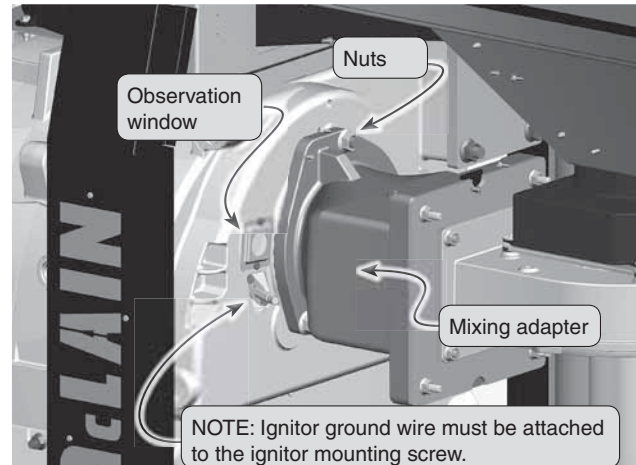
### Check control settings

1. Use the Sola display to navigate through all settings. Adjust settings if necessary.
2. Check settings of external limit controls (if any) and adjust if necessary.

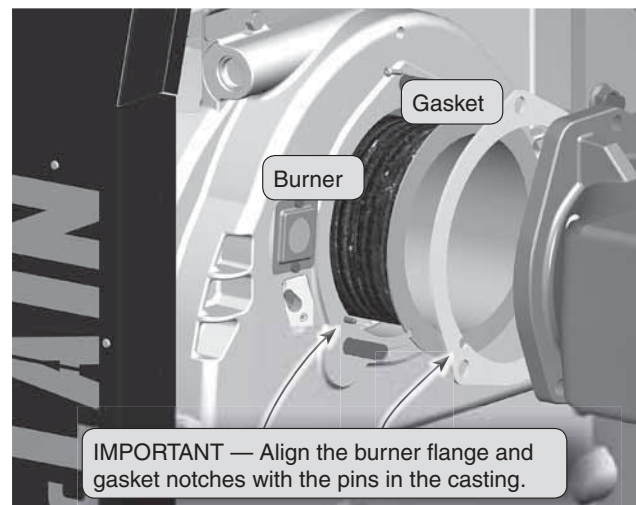
**Figure 96** Gas valve and venturi



**Figure 97** Burner access



**Figure 98** Burner removal and replacement





## Annual startup *(continued)*

### Perform startup procedure per manual

1. Perform all startup procedures on pages page 90 through page 93.

### Check burner flame

1. Inspect flame through the observation window using the procedure on page 90.
  - a. The high fire flame should be blue and should be stable. The burner surface should be covered with orange dots.
  - b. The low fire flame should be stable and evenly distributed over burner surface with a uniform orange color.
2. If the flame is unsatisfactory at either high fire or low fire, perform the testing specified on page 90. If the problem remains, turn off the boiler and allow the boiler to cool down.

### To access the burner:

**▲WARNING** The boiler contains ceramic fiber materials. Use care when handling these materials per instructions on page 97 of this manual. Failure to comply could result in severe personal injury.

1. Shut off power to unit.
2. Disconnect the two wire harnesses from the blower.
3. Remove the wire harnesses (and ground wire) from the igniter (burner end section) and flame sense assembly (piping end section).

**▲WARNING** Use a Phillips-head screwdriver to remove the igniter assembly (burner end section) and flame sense assembly (piping end section, Figure 99, item 6) before removing the burner. Damage to the burner and or igniters can occur during this process.

4. Remove the piping end section combustion chamber access cover (item 11 in Figure 99).
  - a. Items are: cover plate (item 1), three nuts (item 2), refractory (item 3), screw-on refractory clip (item 4), gasket (5).

**NOTICE** Leave the refractory attached to the access plate unless the refractory has to be replaced.

5. Remove plastic reference tube from venturi (Figure 96) — Push in on the tube and the plastic ring on the tube fitting. While keeping the ring pushed in, pull out on the tube.
6. Pull the air flow switch tube off of the hose barb on the venture (Figure 96).
7. Disconnect the air inlet hose from Venturi (Figure 96):
  - a. SF1000 & SF1500 — Remove M5 flange bolts (4) from venturi / air inlet hose connection with 8mm socket.
  - b. SF2000 — Remove M8 bolts (4) from venturi / air inlet hose connection with 13mm socket.
8. Remove the M5 bolts (4) from the gas valve to gas manifold assembly with 4mm Allen wrench (Figure 96).
9. Remove the M12 Flange nuts(3) from Mixing adapter and front section with 17mm wrench or socket (Figure 97).
10. Carefully slide blower/venturi/mixing adapter off of M12 studs, the assembly can be placed nearby.

Figure 99 Combustion chamber access cover removal

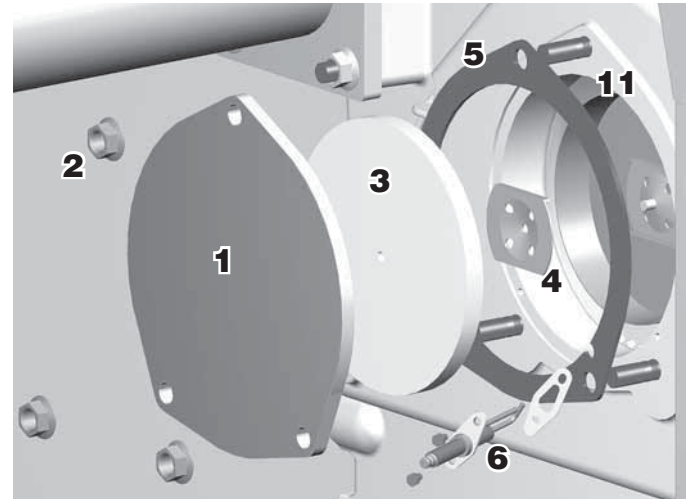
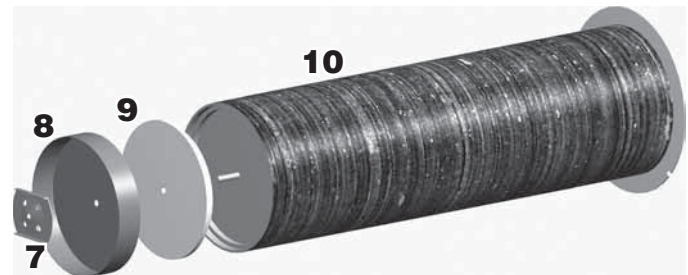


Figure 100 Burner end assembly



**▲WARNING** The blower/venturi/mixing adapter assembly is heavy, weighing up to 60 pounds on larger units. Handle carefully to avoid possible personal injury or damage to the components.

11. Remove the burner gasket.
12. Remove the burner:
  - a. Place your hand and or arm inside the burner for control and stability during removal.

**▲WARNING** There may be sharp edges on and inside the burner. Use proper protection on your hand and arm to prevent possible personal injury.

- b. Slowly pull the burner out, being careful not to drag the Fiber mesh on the casting during the process.

13. Clean the burner:

- a. Vacuum cleaner method — Vacuum inside and out, being careful not to rub or scrape the fiber mesh.

**▲WARNING** Compressed air method — Take precautions, including close-fitting eye protection, due to possible airborne debris during use of compressed air.

- b. Water flush — **Water Only!** — Before water can used, the refractory disc needs to be removed from the end of the burner (see Figure 100). Carefully twist the screw-on clip (item 7) counter clockwise to remove it from the burner (item 10).



## Annual startup *(continued)*

This should allow for removal of the metal dish (item 8) and the refractory disc (item 9). Then rinse the burner from inside out. Allow to dry completely. Re-attach the refractory disc and retainer to the burner after cleaning.

14. Re-install the burner:
  - a. Carefully insert the burner, avoid dragging fiber mesh as its inserted.
  - b. Align small dowel pins at the 5 and 7 o'clock positions with the notches in the burner flange.
  - c. Insert burner into machined pocket on end section, burner should tilt down slightly as the end of the burner rests on opposite end section
  - d. Place Burner gasket over studs and against burner
15. Carefully slide blower/venturi/mixing adapter onto the M12 studs.


**WARNING** The blower/venturi/mixing adapter assembly is heavy, weighing up to 60 pounds on larger units. Handle carefully to avoid possible personal injury or damage to the components.

16. Make sure that the burner flange is still resting inside the machined pocket on the end section.
17. Tighten the M12 flange nuts on the Mixing adapter to 22 Ft-lbs (30 N-m).
18. Connect gas manifold back to gas valve with the M5 Allen bolts (4), with torque 53 in-lbs (6 N-m). **Make sure O-ring is still in position on the gas valve.**
19. Reconnect air inlet pipe to venturi, with torque 53 in-lbs (6 N-m).
20. Reconnect plastic reference line to venturi push tube into fitting. The fitting will self-tighten on the tube. Test the connection by lightly pulling on the plastic tube.
21. Press the air flow switch tube back onto the venturi hose barb.

**WARNING** The air flow switch hose and plastic reference line **MUST** be replaced correctly on the venturi.

22. Reconnect the two blower wire harnesses.
23. Re-install the piping end section combustion chamber access plate assembly. Tighten the M12 flange nuts on the access plate 22 Ft-lbs (30 N-m).
24. Re-install the igniter assembly and flame sensor assembly. Make sure the gaskets are in good condition.
25. Re-attach the wiring connections to the igniter and flame sensor.
26. Verify there are no gas/air leaks.
27. Reconnect any wiring that was disconnected.
28. Retest the boiler, making sure the flame is acceptable after the cleaning.

### Check flame signal

1. On the Sola display, navigate to HOME PAGE  DETAILS. Then use the upper right or left scroll arrow to toggle to the Flame Detection screen.
2. The screen will show whether flame has been detected and list the flame signal value.
3. You can hit the ANALYSIS button to go to the Trend Analysis page (see page 64 for explanation). Select Flame signal, press START

TRENDING, and then press VIEW. The graph will show flame signal value vs time.

4. The flame signal strength will change with firing rate, the value increasing with firing rate increase. Check the flame signal both at maximum and minimum firing rate, with the burner running steady.
  - a. Force the boiler to low fire using the procedure in Figure 88, page 90.
  - b. Use the Sola display to see the flame signal strength using the procedure described above.
  - c. The flame signal must be at least 0.8 volts at low fire.
  - d. Force the boiler to high fire using the procedure in Figure 88, page 90.
  - e. Use the Sola display to see the flame signal strength using the procedure described above.
  - f. The high fire flame signal should be higher than the low fire signal, typically 14 volts or more.
5. If the flame signal is lower than it should be, the flame sensor may be fouled or its ceramic insulator may be damaged.
  - a. Remove, inspect and clean the flame sensor assembly using the method in "Inspect flame sense assembly" on page 100.
  - b. If flame signal remains low after cleaning, replace the flame sensor assembly.

### Check flue gas temperature

1. Set the boiler to high fire. Then adjust the Sola module display to view flue gas temperature and boiler return temperature.
2. The flue gas temperature should be no more than 30°F higher than the boiler return temperature.
3. If the flue temperature is higher than this, shut down the boiler, allow to cool, and follow the procedure starting on page 112 to clean the heat exchanger.

### Check blower speeds

1. If blower speed settings in the Sola have not already been checked, follow the Startup procedure, page 90, to check (and change if necessary) the blower speed settings in the Sola control.

### Review with owner

1. Review the SlimFit User's Information Manual with the owner.
2. Emphasize the following to the owner:
  - a. Perform the maintenance schedule specified in the User's Information Manual.
  - b. Call a licensed contractor should the boiler or system exhibit any unusual behavior.
  - c. Follow the proper shutdown procedure.
  - d. Schedule an annual startup at the beginning of the next heating season.



# Troubleshooting

## VERIFY PROPER OPERATION AFTER SERVICING.

**CAUTION** Before servicing and making connections . . . **ALWAYS TURN POWER OFF TO THE BOILER TO PREVENT ELECTRICAL SURGES, WHICH CAN DAMAGE BOILER COMPONENTS.**

**NOTICE** Before calling, always complete the “SlimFit Gas Data Collection Sheet” (page 111).

Record the boiler size and CP number (located on boiler top jacket panel, next to the air inlet connection).

**WARNING** **ELECTRICAL SHOCK HAZARD** — The boiler ON/OFF switch does not turn off all power to the boiler. **TURN OFF ALL POWER TO THE BOILER WHEN SERVICING.** Internal wiring is still powered when the switch is off.

Label all wires prior to disconnection when servicing controls. Wiring errors can cause improper and dangerous operation. Always disconnect power to boiler before servicing. Failure to comply could result in severe personal injury, death or substantial property damage.

**WARNING** Never jumper (bypass) any device except for momentary testing. Severe personal injury, death or substantial property damage can result.

## Before troubleshooting:

1. See Figure 101 for tools and kits recommended for troubleshooting SlimFit boilers.
2. Check for 120 VAC (minimum 102 VAC to maximum 132 VAC) to boiler.
3. Follow the instructions on page 62 to use the Sola display to review lockout and alert events.

**Figure 101** Tools and kits for troubleshooting

Tools needed	Purpose
#2 Phillips Screwdriver	Remove 4 screws to remove the top front cover
1/16" flat blade screwdriver	Used for wiring on terminal blocks.
3/16" Allen Wrench (Hex Key)	To remove gas valve pressure tap plugs
13 mm Nut driver/ratchet	To remove the heat exchanger cleanout plate, mixing tube or blower
3 mm Allen wrench (Hex Key)	To adjust gas valve throttle
4 mm Allen wrench (Hex Key)	To add orifice to change from natural to propane

Tools needed	Purpose
13 mm wrench	To access combustion system and heat exchanger assembly, blower or mixing tube
Multimeter	To take measurement readings on sensors and electrical components
Manometer (Inclined or digital)	To measure the gas pressure coming to the boiler.
Combustion analyzer (Digital preferred)	For combustion testing.
Contact thermometer	For checking surface temperatures of heat exchanger and pipes
T40 Torx driver	For gas valve offset adjustment
8 mm wrench	For gas piping to venturi



# Troubleshooting *(continued)*

## Check the following:

1. Space heating:
  - a. Make sure thermostat is calling for heat and contacts (including appropriate zone controls) are closed.
  - b. Check for 24 VAC between thermostat wire nuts and ground.
2. DHW:
  - a. Make sure tank aquastat is calling for heat.
3. BMS systems
  - a. Make sure the BMS is calling for heat.
4. Make sure all external limit controls are either installed (and closed) or temporarily jumpered for testing.
5. Make sure that connectors to the Sola control module are securely plugged in at module and originating controls and harness connectors.
6. Gas pressure must be as specified on page 49. Make sure gas pressure switches are not tripped.

## Check control circuit fuse

1. Turn OFF power to boiler at external line switch.
2. Remove jacket access panel.
3. Locate the fused terminal block in the control harness (Figure 102).
4. Remove, inspect and replace the fuse, if necessary. The fuse must be 2-amp 74-5FG2A automatic-style cartridge fuse.

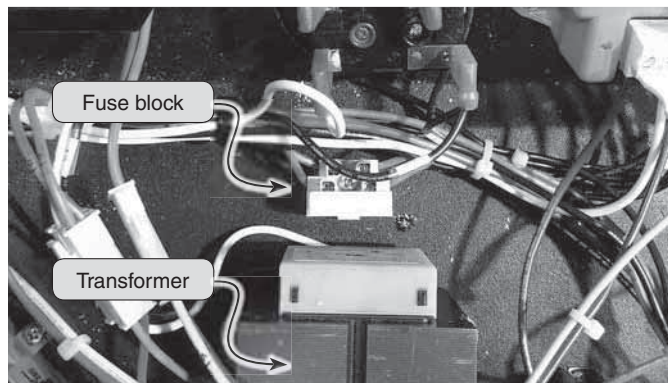
**⚠ WARNING** Do not jumper the fuse or replace with any fuse except as specified. Failure to comply could result in severe personal injury, death or substantial property damage.

5. Reinstall jacket top access panel.
6. Restore power to the boiler at external line switch and verify boiler operation after completing boiler service.

## Checking temperature sensors

1. The boiler temperature sensors are all resistance-type devices.
2. Figure 103 shows the correct value for each sensor at various temperatures.
3. Use the resistance values at 32°F, 60°F, 70°F and 212°F to measure the sensor resistance at known temperatures (freezing point, room temperature and sea level boiling point). For freezing point and boiling point, insert the sensor in water at that temperature. Use an ohmmeter to read resistance value.
4. To check whether the control module is correctly sensing temperature, you can use a resistance decade box. Connect the decade box temporarily in place of a sensor and read the corresponding temperature on the Sola display. The temperature should be close to the value corresponding to the input resistance.

**Figure 102** Control circuit fuse block in control harness



**Figure 103** Sensor resistance values

Sensor resistances for Return sensor, Outdoor sensor, Header sensor					
Temp (°F)	Sensor ohms		Temp (°F)	Sensor ohms	
	Min	Max		Min	Max
32	34265	37871	120	4517	4992
40	27834	30764	130	3698	4088
50	21630	23907	140	3043	3364
60	16944	18727	150	2517	2782
70	13372	14780	160	2091	2311
80	10629	11747	170	1744	1928
90	8504	9399	180	1461	1615
100	6847	7568	190	1229	1359
110	5545	6129	200	1038	1147

Sensor resistances for Boiler outlet sensor, Flue temperature sensor			
Temp (°F)	Sensor ohms	Temp (°F)	Sensor ohms
32	32624	131	2982
41	25381	140	2483
50	19897	149	2079
59	15711	158	1748
68	12493	167	1476
77	10000	176	1252
86	8056	185	1066
95	6530	194	912
104	5324	203	782
113	4365	212	674
122	3599		





# Troubleshooting *(continued)*



Make sure to determine the causes of outages. Do not leave the boiler operating without a complete diagnosis.

## Sola control lockout causes

Lockout occurs if any of the following occur during the indicated period:

1. INITIATE Period:
  - a. A/C line power errors occurred.
  - b. Four minute INITIATE period has been exceeded.
2. STANDBY Period:
  - a. Flame signal is present after 240 seconds.
  - b. Preignition Interlock is open an accumulative time of 30 seconds.
  - c. Interlock Start check feature is enabled and the Interlock String is closed for 120 seconds with the controller closed. (jumpered or welded Interlock).
  - d. Main Valve is energized.
  - e. Internal system fault occurred.
3. PREPURGE Period:
  - a. Preignition Interlock opens anytime during PREPURGE period.
  - b. Flame signal is detected for 10 seconds accumulated time during PREPURGE.
  - c. Purge Rate Blower RPM fails to close within four minutes and fifteen seconds after the firing rate motor is commanded to drive to the high fire position at the start of PREPURGE.
  - d. Light off Rate Blower RPM fails to close within four minutes and fifteen seconds after the firing rate motor is commanded to drive to the low fire position at the end of PREPURGE.
  - e. Lockout Interlock (if programmed) does not close within 10 seconds.
  - f. Lockout Interlock opens during PREPURGE.
  - g. Main Valve is energized.
  - h. Internal system fault occurred.
4. PRE-IGNITION TIME
  - a. Lockout Interlock opens.
  - b. Preignition Interlock opens.
  - c. Main Valve is energized.
5. MAIN FLAME ESTABLISHING PERIOD (MFEP).
  - a. Lockout Interlock opens (if enabled).
  - b. Main Valve is not energized.
  - c. No flame present at the end of MFEP.
  - d. Internal system fault occurred.
6. RUN Period:
  - a. No flame is present, or flame is lost.
  - b. Lockout Interlock opens.
  - c. Main Valve is not energized.
  - d. Internal system fault occurred.
7. POSTPURGE Period.
  - a. Preignition Interlock does not close in five seconds.
  - b. Main Valve is energized.
  - c. Internal system fault occurred.
  - d. Flame sensed 240 seconds accumulated time after the RUN period.

## Shutdown behavior due to lockout

1. If the lockout interlocks open or a sensor designated as a safety limit are read as defective, the Sola control will lockout and the blower motor will be de-energized.
2. If these open during the firing period, all fuel valves will be de-energized, the system will complete postpurge, and will lockout indicated by an alarm.
3. If the main flame is not detected at the end of the last recycle attempt of the main flame establishing period, all fuel valves will be de-energized, the device will complete postpurge, and will lockout indicated by an alarm.
4. Manual reset is required following any lockout.
5. Manual reset may be accomplished by pressing the push button on the Sola module, pressing the SlimFit reset button on top of the boiler, or by using the Sola display.
6. Interrupting power to the Sola control will cause electrical resets, but does not reset a lockout condition.

## Lockouts and alerts

1. See Figure 104, page 106 for common lockout and alert codes.
2. See page 62 for instructions on using the Sola display for lockout and alert histories.



## Troubleshooting *(continued)*

**Figure 104** Sola control History (HOME PAGE ➔ BOILER ICON ➔ DETAILS ➔ HISTORY)

### Sola Lockout History

The Sola is able to record information about the boiler's condition at the time of up to 15 previous lockouts. This information is available to view in the HISTORY menu. Select the LOCKOUTS button at the bottom to see the lockouts page.

Error code	Description	Error code	Description
<b>2</b>	Waiting for safety data verification	<b>91</b>	Inlet sensor fault
<b>3 to 46</b>	Internal Fault	<b>92</b>	Outlet Sensor fault
<b>47</b>	Flame Rode to ground leakage	<b>94</b>	Header sensor fault
<b>49</b>	24 VAC voltage low/high	<b>95</b>	Stack sensor fault
<b>53</b>	AC inputs phase reversed	<b>96</b>	Outdoor sensor fault
<b>63</b>	LCI OFF	<b>105</b>	Flame detected out of sequence
<b>64</b>	PII OFF	<b>106</b>	Flame lost in main flame establishing period
<b>67</b>	ILK OFF	<b>107</b>	Flame lost early in run
<b>79</b>	Outlet High Limit	<b>108</b>	Flame lost in run
<b>81</b>	Delta T limit	<b>109</b>	Ignition failed
<b>82</b>	Stack Limit	<b>122 to 132</b>	Rate proving vaults
<b>85</b>	Inlet/Outlet inversion limit	<b>172-178</b>	Internal Control Relay fault
<b>88</b>	Outlet T-Rise limit	<b>184-250</b>	Parameter setting fault

### Sola Alert History

The Sola is able to record information about the boiler's condition at the time of up to 15 previous alerts. This information is available to view in the HISTORY menu. Select the ALERTS button at the bottom to see the alerts page.

Error code	Description	Error code	Description
<b>25</b>	Lead lag operation switch was turned off	<b>183-203</b>	Lead lag parameter errors
<b>26</b>	Lead lag operation switch was turned on	<b>204-213</b>	Lead lag operation errors
<b>29</b>	Burner switch turned off	<b>268</b>	CH 4mA water temperature setting invalid
<b>30</b>	Burner switch turned on	<b>269</b>	CH 20 mA water temperature setting was invalid
<b>44-70</b>	System operation faults	<b>272-360</b>	Abnormal Recycle
<b>74-81</b>	Fan parameter errors	<b>361-382</b>	Internal errors
<b>84-114</b>	Modulation parameter errors	<b>460</b>	LCI lost in run
<b>115-130</b>	Modulation operation faults	<b>461-463</b>	Abnormal recycle: demand lost in run
<b>131-145 and 150-156</b>	CH parameter errors	<b>467-500</b>	Internal data faults
<b>146-149 and 179-182</b>	CH operation error	<b>540-559</b>	Delta T errors
<b>157-170</b>	DHW Parameter errors	<b>560-575</b>	T rise errors
<b>171-187</b>	DHW operation errors	<b>576-581</b>	Pump errors



# Troubleshooting *(continued)*

Figure 104 Troubleshooting suggestions for SlimFit boilers *(continued)*

## Sola Fault Displays, Diagnostics and Suggested Corrective Actions

Display	Condition	Diagnostics	Corrective actions
<b>Nothing shown on display screen and blower running at full speed</b>	Control is not receiving 24V power	Check wiring for short circuit or incorrect wiring.	• Correct wiring per wiring diagram including connection of transformer.
		Check 2-amp low voltage fuse on transformer shown on page 104, Fig. 102.	• Replace fuse with proper part found in replacement part section of this manual. If fuse blows again recheck wiring per diagram.
		Check transformer connection per wiring diagram. Check for 24V output of transformer.	• Replace transformer if it is receiving 120VAC, but not outputting 24VAC.
<b>Nothing is shown in display screen and no other boiler components are operating</b>	Control is not receiving 120V power	Check service switch and/or circuit breaker to boiler turned is on.	• Turn on service switch to power boiler.
		Is there 120 Volts at the service switch?	• Troubleshoot and correct the power supply to the service switch.
		Is the SlimFit ON/OFF POWER SWITCH located on top of the boiler turned on?	• Turn the SlimFit power switch on top of the boiler to ON.
		Check for 120 volts at the line voltage terminal block located inside the control pod.	• Correct wiring inside the control pod using the wiring diagram in this manual.
<b>Nothing is shown on display screen, but boiler is operating</b>	Occurs when power is lost from the to the display.	Check for loose connections and proper pin alignment/engagement in the main harness and the back of the display circuit board.	• Check for continuity on the wire harness from the display to the SlimFit. See repair parts section for proper replacement part.
		Cycle power off and on using boiler power switch and check for operation.	• Replace with new display module. See repair parts section for proper replacement part.
<b>Boiler Icon not shown on display</b>	Occurs when the communication is lost from the Sola to the display.	Display has been disconnected from Sola Control	• Reconnect and perform synchronization process
		Check for loose connections and proper pin alignment/engagement in the main harness and the back of the display circuit board.	• Check for continuity on the wire harness from the display to the SlimFit. See repair parts section for proper replacement part.
<b>Boiler Icon Black on display</b>	Occurs when the communication is lost from the Sola to the display.	Display has been disconnected from Sola Control	• Reconnect and perform synchronization process
		Check for loose connections and proper pin alignment/engagement in the main harness and the back of the display circuit board.	• Check for continuity on the wire harness from the display to the SlimFit. See repair parts section for proper replacement part.
<b>Outlet T-Rise Limit</b>	Occurs when supply water temperature in heat exchanger rises faster than 2°F per second.	Automatically resets after 5 minute delay or using manual reset on display.	• Verify water piping is installed correctly using primary/secondary connection to the boiler loop. Verify that piping methods and sizes comply with the instructions in this manual.
			• Verify proper pump sizing for boiler size and system requirements.
			• Verify boiler pump is energized
			• See message displayed Inlet sensor fault or outlet sensor fault and follow procedure for loose connections.
<b>Delta-T inlet/outlet limit</b>	Boiler Out temperature has exceeded the Boiler In temperature by more than 58°F	Automatically resets after 15 second delay or using manual reset on display.	• Verify water piping is installed correctly using primary/secondary connection to the boiler loop. Verify that piping methods and sizes comply with the instructions in this manual.
		After 20 automatic resets occur in the same heat demand the boiler will need a manual reset.	• Verify proper pump sizing for boiler size and system requirements.
			• Verify boiler pump is energized
			• See message displayed Inlet sensor fault or outlet sensor fault and follow procedure for loose connections.



# Troubleshooting *(continued)*

**Figure 104** Troubleshooting suggestions for SlimFit boilers *(continued)*

Display	Condition	Diagnostics	Corrective actions
<b>Inlet/outlet inversion limit</b>	Occurs when a return water temperature is greater than the corresponding supply temperature for 5 minutes during run.	Manual reset required.	<ul style="list-style-type: none"> <li>Verify proper flow direction of the boiler pump. This pump should be installed to push water through the boiler's return pipe as shown in Figure x on page x.</li> <li>Verify proper placement of system sensors for single or multiple boiler systems. System sensors should be on system piping not on the boiler loop.</li> <li>System sensors may need to be located further away from boiler loop connection to the system if proximity to the boiler loop is causing sensors to be heated inaccurately.</li> </ul>
<b>Inlet Sensor fault; Outlet Sensor fault; Header Sensor fault; Stack Sensor fault; Outdoor sensor fault</b>	Occurs when a temperature sensor has electrically shorted or has become disconnected.	Automatically resets if sensors begin reading temperatures.	<ul style="list-style-type: none"> <li>Check all the temperature readings of the boiler on the Boiler Icon-Diagnostics-Analog I/O and determine if any sensors are currently displayed as SHORT or OPEN.</li> <li>Determine which sensors are suspect and measure their resistance value and compare it to the values shown in Figure 103, page 104. If the resistance values are incorrect, replace the temperature sensor. Refer to repair parts section for proper part number.</li> <li>OUTDOOR/HEADER are the optional outdoor air temperature and system water temperature sensors. If these are not being used they will always be shown as OPEN. This is normal unless the sensors were installed.</li> <li>Check wire harness for loose connections and pin engagement at sensor connection, chassis mount connection through sheet metal cabinet, and Sola Control module. Unplug connection at sensor and at Sola control and check continuity between ends.</li> <li>If problem persists after checking items above replace Sola Control. Refer to repair parts section for kit number.</li> </ul>
	Occurs when dual temperature sensors values have spread by more than 6°F	Automatically resets when sensors are within 6°F.	<ul style="list-style-type: none"> <li>Follow procedure for above for SHORT and OPEN sensor conditions to properly diagnose sensor. If measured resistance values of sensors convert to temperatures separated by more than 6°F replace the sensor.</li> </ul>
<b>Stack Limit</b>	Occurs when flue temperature sensor exceeds 216°F	Automatically resets after 5 minute delay.	<ul style="list-style-type: none"> <li>Follow procedure for above for SHORT and OPEN sensor conditions to properly diagnose sensor. In addition inspect heat exchanger combustion chamber and flue ways for abnormal wear or buildup.</li> <li>Inspect vent system for abnormal wear or damage.</li> <li>Contact Weil-McLain Technical Support.</li> </ul>
<b>Outlet High Limit</b>	Boiler outlet temperature sensor reached 200°F	Reset with manual reset on display	<ul style="list-style-type: none"> <li>Verify all isolation valves are open and pumps are programmed into the Sola Control properly. Refer to the Sola Control Setup section to configure these properly for the system.</li> <li>Verify water piping is installed correctly using primary/secondary connection to the boiler loop. Verify that piping methods and sizes comply with the instructions in this manual.</li> <li>Verify proper pump sizing for boiler size and system requirements.</li> <li>Verify boiler pump is energized</li> </ul>
<b>Flame detected out of sequence</b>	Occurs when flame is detected when there should be no flame	Reset with manual reset on display	<ul style="list-style-type: none"> <li>See message displayed Inlet sensor fault or outlet sensor fault and follow procedure for loose connections.</li> <li>Verify FLAME value on the (Boiler Icon) screen quickly goes to zero when the gas valve closes.</li> <li>Check for flame at burner via flame current with burner off. Turn boiler off and watch flame through observation port. If flame continues after shutdown replace gas valve and venturi.</li> </ul>
<b>Flame lost early in run or Flame lost in run</b>	Flame lost after ignition	Automatically resets after 5 minute delay.	<ul style="list-style-type: none"> <li>Check gas supply pressure</li> <li>Inspect flame sense electrode and wiring</li> </ul>



# Troubleshooting *(continued)*

Figure 104 Troubleshooting suggestions for SlimFit boilers *(continued)*

Display	Condition	Diagnostics	Corrective actions
<b>Light off rate proving failed;</b> <b>Purge rate proving failed;</b> <b>Fan speed failed during prepurge;</b> <b>Fan Speed failed during preignition;</b> <b>Fan speed failed during ignition;</b> <b>Fan Speed failed during run;</b> <b>Fan movement detected during standby</b>	Blower unable to reach required speed or does not reach 0 RPM when turned off.	Requires a manual reset.	<ul style="list-style-type: none"> <li>Check wire harness for loose connections and pin engagement at blower connections, chassis mount connection through sheet metal cabinet, and Sola module. Unplug connection at sensor and at Sola and check continuity between ends. Blower is connected to both low voltage and line voltage harness.</li> <li>Check FAN Boiler Icon-Diagnostics-Analog I/O screen with boiler in standby mode and blower not running. If BLOWER SPEED is not 0 RPM then replace blower.</li> <li>If blower does not rotate during ignition sequence check for 120V power at blower connection. If 120Vac power at blower motor and it doesn't start replace blower. Check power at Blower relay. If 120Vac is not present at Relay when boiler is powered replace Relay. Refer to repair parts section.</li> </ul>
<b>Ignition Failed</b>	Boiler went through 2 ignition attempts and never detected flame A fault has occurred in the control hardware	Requires a manual reset.	<ul style="list-style-type: none"> <li>Fouled, worn, bent, or faulty igniter or flame sense rod. Fouled igniters and flame sensors can be cleaned for additional use with fine grit sand paper or steel wool. Worn or badly fouled igniters and flame sense rods should be replaced with the proper repair part. Igniter rods should be parallel with a 3.0mm (0.118in) spark gap.</li> <li>Dirty burner and/or heat exchanger will cause high back pressure and poor ignition. Follow procedure in maintenance section of this manual to clean burner and heat exchanger using flue cleaning tool and rinse method.</li> <li>Visual inspection of flue ways will often will not be able to diagnose condition.</li> <li>Check combustion settings on high and low fire and adjust per setup instructions if necessary.</li> <li>Check incoming gas pressure with boiler off, at high fire, and at low fire. Adjust within limits on rating label.</li> <li>Verify high altitude settings have been changed for installations 5,500 ft. above sea level.</li> <li>Check ignition cable resistance. Should measure 1000 Ohms (+/- 50 Ohms)</li> <li>Check continuity of flame sense cable.</li> <li>Check ignition transformer is plugged in. If no spark present during ignition replace spark transformer</li> <li>Check for flue pipe and intake pipe restrictions or blockage</li> <li>Check burner fasteners and gaskets</li> <li>Check venturi gaskets</li> <li>Check condensate trap for blockage allowing condensate to accumulate inside heat exchanger</li> </ul>
<b>Internal Fault</b>		Requires a manual reset.	<ul style="list-style-type: none"> <li>Reset control, If fault returns replace Sola control</li> </ul>
<b>ILK OFF (Flue Pressure)</b>	Flue pressure switch is opened during run	Requires manual reset.	<ul style="list-style-type: none"> <li>Check for flue pipe and intake pipe restrictions or blockage</li> <li>Check continuity of flue pressure switch and flue pressure switch wiring</li> </ul>
<b>ILK OFF (Block Temperature)</b>	Block temperature switch reached 203°F	Requires manual reset	<ul style="list-style-type: none"> <li>Verify water piping is installed correctly using primary/secondary connection to the boiler loop. Verify that piping methods and sizes comply with the instructions in this manual.</li> <li>Verify proper pump sizing for boiler size and system requirements.</li> <li>Verify boiler pump is energized</li> <li>See message displayed Inlet sensor fault or outlet sensor fault and follow procedure for loose connections.</li> </ul>



# Troubleshooting *(continued)*

**Figure 104** Troubleshooting suggestions for SlimFit boilers *(continued)*

Display	Condition	Diagnostics	Corrective actions
<b>ILK OFF (Gas Pressure Low)</b>	Low gas pressure switch is open	Requires manual reset of low gas pressure switch and Sola Control	<ul style="list-style-type: none"> <li>Check gas supply pressure, adjust regulator to specification</li> </ul>
<b>ILK OFF (Gas Pressure High)</b>	High gas pressure switch is open	Requires manual reset of high gas pressure switch and Sola Control	<ul style="list-style-type: none"> <li>Check gas supply pressure, adjust regulator to specification 100% Lockup regulator required</li> </ul>
<b>ILK OFF (Low Water Level)</b>	Occurs when Low Water Cutoff Device detects Low water condition	Requires manual reset of low water cutoff and Sola control.	<ul style="list-style-type: none"> <li>Check for low water condition in system. Repair system as necessary refer to piping section of this manual.</li> </ul>
			<ul style="list-style-type: none"> <li>If low water condition does not exist check Low water level Boiler Icon-Diagnostics-Digital I/O screen to view status of Low Water Cutoff. If shown as OFF check wiring between LWCO and Sola.</li> </ul>
			<ul style="list-style-type: none"> <li>Probe may be checked by grounding the tip of the probe to the heat exchanger. If fault continues after reset, replace LWCO probe</li> </ul>
<b>ILK OFF (External Limit)</b>	Occurs when external limit opens (ILK).	Requires manual reset	<ul style="list-style-type: none"> <li>Is there an external safety device connected? If yes, trouble shoot the external limit to determine and correct the cause that opened the limit. Also check for loose wiring connections.</li> </ul>
			<ul style="list-style-type: none"> <li>If no external safety devices are installed, remove the top cover and ensure a jumper is installed between ILK terminals on terminal block</li> </ul>
<b>LCI OFF (Min Air Flow Switch)</b>	Min air flow switch is opened during run	Automatically resets.	<ul style="list-style-type: none"> <li>Check for flue pipe and intake pipe restrictions or blockage</li> </ul>
			<ul style="list-style-type: none"> <li>Check continuity of flue pressure switch, normally open switch (no air flow) Check minimum air flow switch relay in control tray. Terminals 4 and 5 should be normally closed, when gas valve energizes terminals 4 and 5 should open Check continuity of minimum air flow switch relay wiring</li> </ul>
<b>LCI OFF (Load Control Input)</b>	Occurs when external limit opens (LCI).	Automatically resets. Boiler will not enter prepurge until LCI is closed	<ul style="list-style-type: none"> <li>Is there an external safety device connected? If yes, trouble shoot the external limit to determine and correct the cause that opened the limit. Also check for loose wiring connections.</li> </ul>
			<ul style="list-style-type: none"> <li>If no external safety devices are installed, remove the top cover and ensure a jumper is installed between LCI terminals on terminal block</li> </ul>
<b>PII OFF (Pre-Ignition ILK)</b>	Occurs when external limit opens (PII).	Requires manual reset. Ignored during run	<ul style="list-style-type: none"> <li>Is there an external safety device connected? If yes, trouble shoot the external limit to determine and correct the cause that opened the limit. Also check for loose wiring connections.</li> </ul>
			<ul style="list-style-type: none"> <li>If no external safety devices are installed, remove the top cover and ensure a jumper is installed between PII terminals on terminal block</li> </ul>



**SlimFit Gas Boiler Data Collection Sheet**

Customer Info:		Job Info:	
Contact:		Job name:	
Contractor:		Job address:	
Distributor:		City, state:	

Maintenance Info:	
Name:	
Phone:	
Model:	
CP#:	
Installed:	

**Boiler/System Piping Details (Please Sketch)**

Please note the placement of system sensors

System Components:	
Near boiler piping size:	
Boiler Circulator model:	
DHW tank (yes/no)	
DHW model:	
DHW pipe size	
DHW circulator model:	
Is there air in system?	

Lockout History	
Lock out (Red text)	
Cycle:	
Hours:	
State:	
Timer:	
First out:	
Pump A =	
Pump B =	
Pump C =	
Blower/HSI =	
External Ignition =	
Pilot Valve =	
Main Valve =	
Alarm =	
Flue Press. Switch =	
Pre-Ignition ILK =	
Load Control Input =	
STAT =	
Time of Day =	
Safety Relay =	
Low Water Level =	
Gas Pressure Low =	
Gas Pressure High =	
Block Temperature =	
Min Air Flow switch =	
Inlet =	
Outlet =	
Domestic Hot Water (DHW) =	
Outdoor =	
Stack =	
4-20mA =	
Data =	

Lockout History	
Lock out (Red text)	
Cycle:	
Hours:	
State:	
Timer:	
First out:	
Pump A =	
Pump B =	
Pump C =	
Blower/HSI =	
External Ignition =	
Pilot Valve =	
Main Valve =	
Alarm =	
Flue Press. Switch =	
Pre-Ignition ILK =	
Load Control Input =	
STAT =	
Time of Day =	
Safety Relay =	
Low Water Level =	
Gas Pressure Low =	
Gas Pressure High =	
Block Temperature =	
Min Air Flow switch =	
Inlet =	
Outlet =	
Domestic Hot Water (DHW) =	
Outdoor =	
Stack =	
4-20mA =	
Data =	

Lockout History	
Lock out (Red text)	
Cycle:	
Hours:	
State:	
Timer:	
First out:	
Pump A =	
Pump B =	
Pump C =	
Blower/HSI =	
External Ignition =	
Pilot Valve =	
Main Valve =	
Alarm =	
Flue Press. Switch =	
Pre-Ignition ILK =	
Load Control Input =	
STAT =	
Time of Day =	
Safety Relay =	
Low Water Level =	
Gas Pressure Low =	
Gas Pressure High =	
Block Temperature =	
Min Air Flow switch =	
Inlet =	
Outlet =	
Domestic Hot Water (DHW) =	
Outdoor =	
Stack =	
4-20mA =	
Data =	

Lockout History	
Lock out (Red text)	
Cycle:	
Hours:	
State:	
Timer:	
First out:	
Pump A =	
Pump B =	
Pump C =	
Blower/HSI =	
External Ignition =	
Pilot Valve =	
Main Valve =	
Alarm =	
Flue Press. Switch =	
Pre-Ignition ILK =	
Load Control Input =	
STAT =	
Time of Day =	
Safety Relay =	
Low Water Level =	
Gas Pressure Low =	
Gas Pressure High =	
Block Temperature =	
Min Air Flow switch =	
Inlet =	
Outlet =	
Domestic Hot Water (DHW) =	
Outdoor =	
Stack =	
4-20mA =	
Data =	



# Maintenance

## Disconnect power before servicing

**⚠ WARNING** Electrical shock hazard — Disconnect all electrical power to the boiler before attempting maintenance procedures. Failure to complete could result in severe personal injury, death or substantial property damage.

## Perform startup and check/out

**⚠ WARNING** Removing and reinstalling components can change boiler behavior.

After any maintenance procedure, you must verify operation after servicing. To do so, follow the complete procedure for boiler and system startup, beginning on page 87. Failure to comply could result in severe personal injury, death or substantial property damage.

**⚠ CAUTION** Label all wires prior to disconnection when serving controls. Wiring errors can cause improper and dangerous operation.

## General maintenance

1. Oil motors in system requiring regular oiling.
2. See Oiled bearing pumps for motor oiling procedures.

## Oiled-bearing pumps

1. Check pumps in the system. Oil any pumps requiring oil, following pump manufacturer's instructions. Over-oiling will damage the pump.

## Clean the heat exchanger when required — water side

1. In order for the efficiency of boilers to increase beyond the condensing limit, new materials have been introduced for the heat exchanger, including aluminum.
2. Aluminum has excellent heat transfer characteristics and is light in weight.
3. These new materials also require cleaning solutions that differ from those used in conventional cast iron and steel boilers.

**⚠ WARNING** One common cleaning method that **CANNOT** be used with systems containing aluminum is a solution of trisodium phosphate, commonly referred to as "TSP."

The reason that trisodium phosphate cannot be used is that the cleaning solution has a very high pH level — while removing the scale in the system, it also removes the natural protective oxide layer from the aluminum. The oxide layer will reform, but if small amounts of the trisodium phosphate remain in the system, the chemical will continue to remove the protective oxide layer, leading to reduced heat exchanger life.

4. Use **ONLY** the cleaning product available from Weil-McLain, Sentinel X400. See the Repair Parts section at the end of this manual for ordering information.

## Clean the heat exchanger when required — flue side

1. Shut down boiler:
  - a. Follow "To Turn Off Gas to Appliance" instructions on boiler and Lighting instructions.
  - b. Do not drain boiler unless it will be exposed to freezing temperatures. If using freeze prevention fluid in system, do not drain.
2. Allow time for boiler to cool to room temperature if it has been firing.

## Remove heat exchanger cleanout plate and burner

1. Close the external manual gas valve.
2. Disconnect all power to the boiler.
3. Allow the boiler to cool if it has been operating.
4. Use a 13-mm wrench or socket to remove the nuts that secure the heat exchanger cleanout plate to the heat exchanger (Figure 105, page 113).
5. Remove the cleanout plate. Handle the cleanout plate gasket carefully to avoid damage.
6. Follow the procedure on page 101 to remove the burner, piping end combustion chamber access plate and the blower/venturi/mixing tube assembly.

## Use heat exchanger cleaning tool

1. Use the heat exchanger cleaning tool (supplied with the boiler) or a piece of 20-gauge or lighter sheet metal  $\frac{3}{4}$ " wide by about 18 inches long to loosen deposits.
2. Slide the cleaning tool through the heat exchanger pins in the three directions shown in Figure 106, page 113.
3. Vacuum most of the debris out of the base through the flue inspection opening.

## Water spray the heat exchanger

1. Disconnect the condensate line at the bottom of the heat exchanger so debris will not clog the trap.
  - a. Loosen the hose clamps at both ends of the condensate line.
  - b. Remove the line and place a pan under the trap connection.
2. Use the combustion chamber openings at either end to spray water down onto the heat exchanger pins. Continue spraying until all debris on the pins has been flushed into the base.
  - a. Spray water into the flue inspection opening to flush remaining sediment to the condensate outlet.
  - b. Spray water through the condensate line to clean it thoroughly.
  - c. Remove the pan and re-install the condensate line.
  - d. Re-install the flue inspection plug.

## Inspect cleanout plate gasket

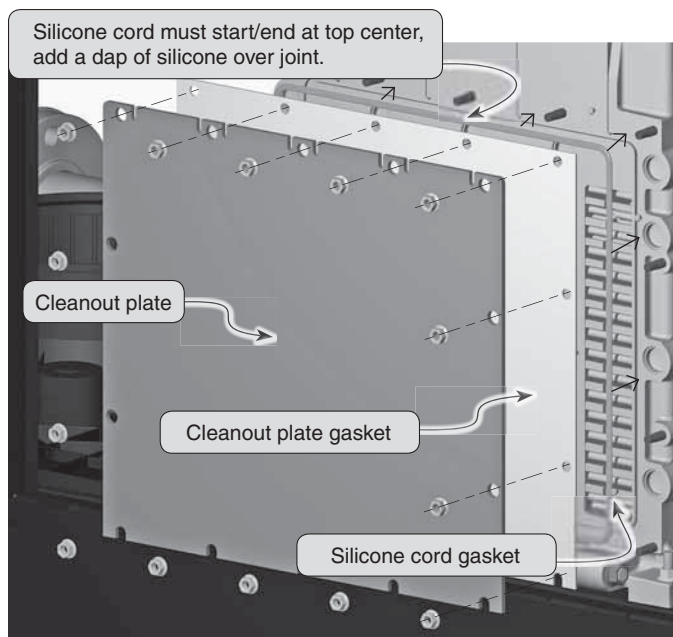
1. Inspect the cleanout plate gasket (Figure 105, page 113). Replace if damaged.





## Maintenance *(continued)*

**Figure 105** Cleanout plate removal/re-installation



### Re-install cleanout plate

1. Install a new silicone cord gasket into the groove. See instructions at right.
2. Re-install the cleanout plate gasket that was removed and inspected earlier.
3. Position the cleanout plate.
4. **See Figure 107, page 114.** Re-install the hex head nuts on the cleanout plate mounting studs and tighten in the staggered pattern shown for the boiler model until the cleanout plate is uniformly tightened.

**▲WARNING** Gradually tighten the cleanout plate nuts in the sequence shown in Figure 107, page 114 until torque reaches 18 N-m/160 in-lbs/13 ft-lbs.

If the tightening is not done using this top-to-bottom, center out method, the plate could buckle, allowing a flue gas leakage.

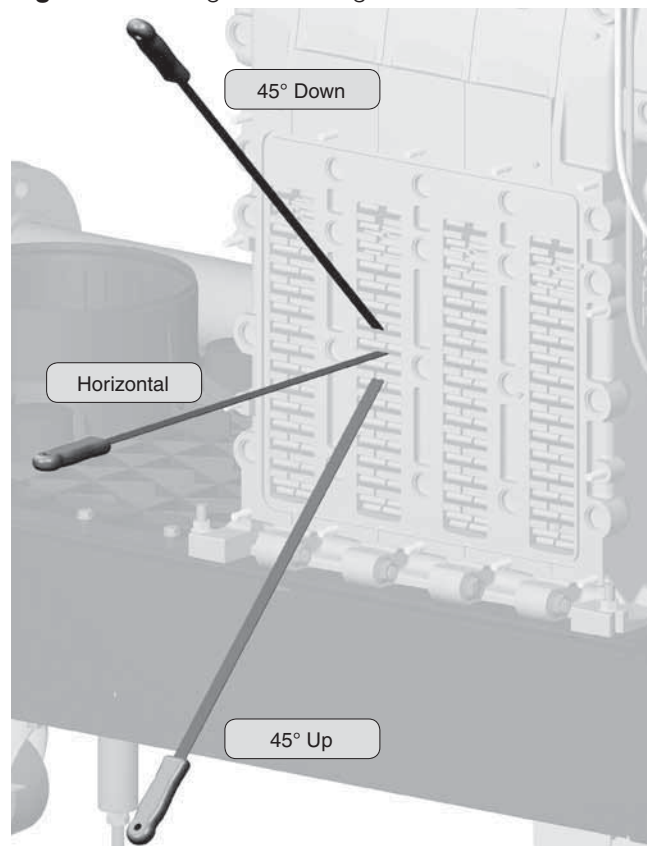
### Re-install venturi/blower/mixing tube assembly

1. Follow the procedure on page 101 to re-install the burner, piping end combustion chamber access plate and the blower/venturi/mixing tube assembly.
2. Reconnect wiring, including the ignitor ground wire connection to the top ignitor mounting screw.

### Restart and test the boiler

1. Restore gas supply and power to the boiler.
2. Start the boiler and verify operation following the procedures given in this manual.

**Figure 106** Using the cleaning tool



**▲WARNING**

**Cleanout plate gaskets** — If the cleanout plate gasket has been damaged, or the silicone cord gasket has been damaged or stretched, replace it before placing the boiler back in operation.

#### To install the silicone cord gasket:

When installing the silicone cord gasket, the seam should start at the top middle of the gasket groove. See Figure 105.

Carefully place the cord in the groove all around the cleanout plate.

Place a dab of silicone on the seam at start and end.

Do not splice pieces together. The gasket must be installed as one piece.

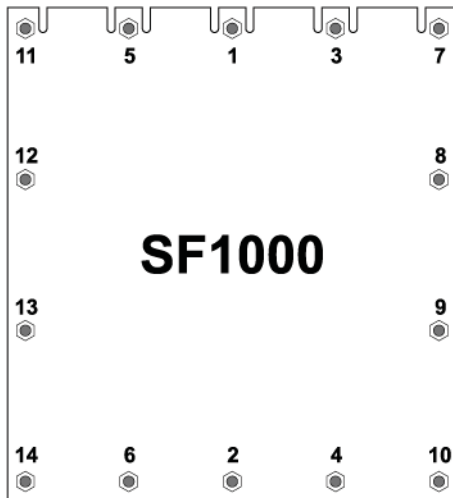
When inserting the gasket, do not stretch the cord or stretch around corners. This could cause the cord not to seal correctly, resulting in possible flue gas or condensate leakage.

Failure to comply could result in severe personal injury, death or substantial property damage.



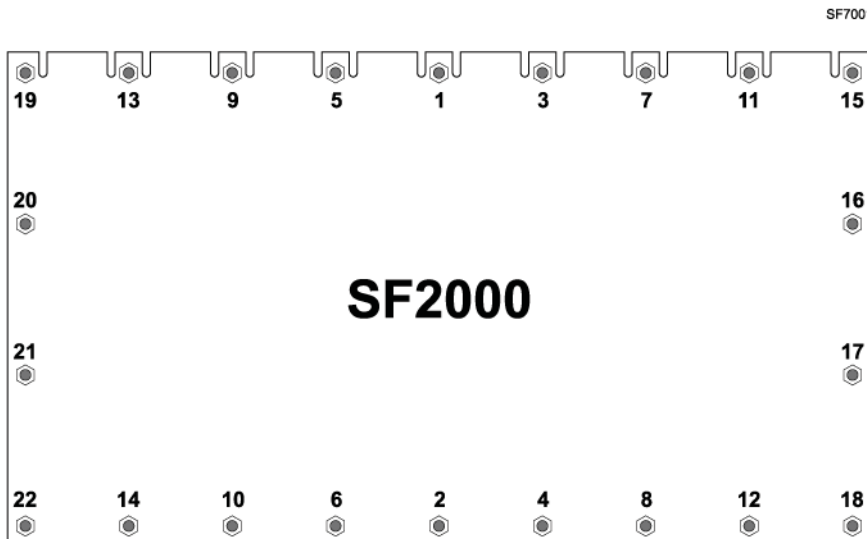
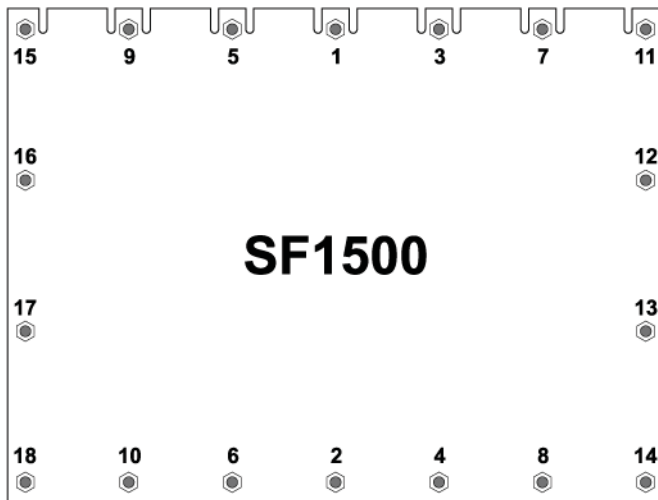
# Maintenance *(continued)*

**Figure 107** Cleanout plate nut tightening sequences



**⚠ WARNING** Gradually tighten the cleanout plate nuts in the sequence shown in Figure 107 until torque reaches 18 N-m/160 in-lbs/13 ft-lbs.

If the tightening is not done using this top-to-bottom, center out method, the plate could buckle, allowing a flue gas leakage.





# Replacement parts

Go to [www.weil-mclain.com](http://www.weil-mclain.com) to locate Weil-McLain distributors

**▲WARNING** Replacement parts must be purchased through a local Weil-McLain distributor. When ordering, specify boiler model and size and include description and part number of replacement part. Results from using modified or other manufactured parts will not be covered by warranty and may damage boiler or impair operation.

**NOTICE** Weil-McLain part numbers are found in Weil-McLain Boilers and Controls Repair Parts Lists.

**▲WARNING** The boiler contains ceramic fiber materials. Use care when handling these materials per instructions on page 97 of this manual. Failure to comply could result in severe personal injury.

**Figure 108** Miscellaneous parts and kits

Item	Description	Part Number for SlimFit 550/750
1	Condensate neutralizer kit (up to 3000 MBH)	383-600-076
2	Heat exchanger cleaning tool	591-706-200
3	Pressure relief valve ASME 30 PSI, 1 1/4" NPT female ASME 50 PSI, 1 1/4" NPT female ASME 80 PSI, 1 1/4" NPT female (includes new P/T gauge) ASME 100 PSI, 1 1/4" NPT female (includes new P/T gauge)	383-600-093 383-600-101 383-600-299 383-600-298
5	Antifreeze, Sentinel X500 (5 liters) . . . . . Corrosion inhibitor, Sentinel X100 (5 gallons) . . . . . Corrosion inhibitor, Sentinel X100 (50 gallons) . . . . . Inhibitor quick-test kit . . . . . Cleaner, Sentinel X400 (one tube, 275 ml) . . . . .	592-900-004 592-900-016 592-900-017 592-900-005 592-900-003
6	Annual maintenance kit consisting of: (1) ignitor (2) washers for ignitor (2) blower connection gaskets (2) ignitor/flame sensor gasket (1) flame sensor (1) length of silicone cord for cleanout (4) screws for ignitor/sensor (1) inhibitor test kit plate	383-600-225
7	Pressure/Temperature Gauge 1/4 NPT 0-75 PSI (for 30 - 50 PSIG relief valves) Pressure/Temperature Gauge 1/4 NPT 0-150 PSI (for 80 - 100 PSIG relief valves)	383-000-000 570-218-055
8	SlimFit Vent/Air Adapter 6 Inch CPVC/PVC – Converts boiler connection to CPVC/PVC diameter.	560-907-739
9	SlimFit Vent/Air Adapter 8 Inch CPVC/PVC – Converts boiler connection to CPVC/PVC diameter.	560-907-738

### Vent/air piping components

Vent Manufacturer	Vent Type	Adapter Description	Vent Mfr's P/N
Centrotherm	InnoFlue SW Polypropylene	Tapered 10" to 6" reducer	ISTR1006
		Tapered 10" to 8" reducer	ISTR1008
DuraVent	PolyPro Polypropylene	9.85" to 6" PP (Exhaust)	810007177
		9.85" Adapter to 6" PP (Air)	810007178
		9.85" Adapter to 8" PP (Exhaust)	810007179
		9.85" Adapter to 8" PP (Air)	810007180
	FasNSeal AL29-4C	9.85" Adapter to 6" FNS (Exhaust)	810007181
		9.85" Adapter to 6" FNS (Air)	810007182
		9.85" Adapter to 8" FNS (Exhaust)	810007183
		9.85" Adapter to 8" FNS (Air)	810007184
Heatfab / Selkirk	SAF-T Vent EZ SEAL AL29-4C	SlimFit adapter to 6"	96WMSF
		SlimFit adapter to 8"	98WMSF
MetalFab Inc.	CORR/Guard AL29-4C	SlimFit adapter to 6"	6FCG9WMA
		SlimFit adapter to 8"	8FCG9WMA
Nova Flex Group	Z-Vent AL29-4C	SlimFit Adaptor 6"	2SVESFA1006
		SlimFit adapter 8"	2SVESFA1008



## Replacement parts *(continued)*

Go to [www.weil-mclain.com](http://www.weil-mclain.com) to locate Weil-McLain distributors

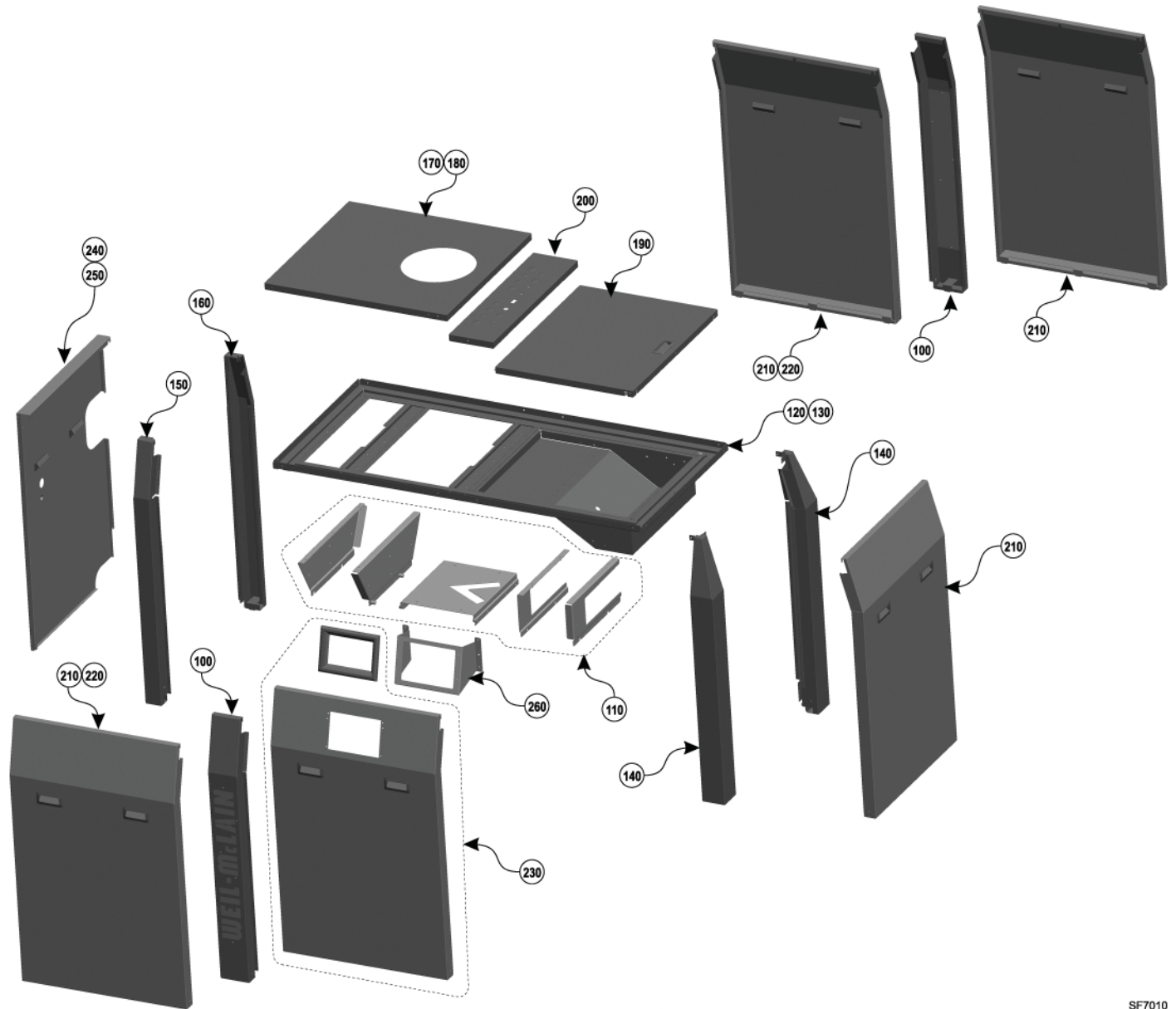
**Figure 109** Jacket parts

Item	Description	Part Number for SlimFit 550/750
100	Jacket side post with mounting plate	426-700-330
110	Support frame bracket kit (Frame components, hardware)	383-600-249
120	Jacket top frame kit, SF1000/1500 (Frame, hardware)	383-600-253
130	Jacket top frame kit, SF2000 (Frame, hardware)	383-600-254
140	Jacket corner post, front (Post, hardware)	383-600-258
150	Jacket corner post, back/left	426-700-315
160	Jacket corner post, back/right	426-700-316
170	Jacket top size C, SF1000/1500 (Panel, hardware)	383-600-261
180	Jacket top size D, SF2000 (Panel, hardware)	383-600-262
190	Jacket top size A (Panel, hardware)	383-600-263
200	Jacket top size B (Panel, plugs, hardware)	383-600-265
210	Jacket access door, size B, SF1000/1500 (Panel with handles)	426-700-325
220	Jacket access door, size C, SF2000 (Panel with handles)	426-700-326
230	Door panel, size A (Panel with handles, bezel, hardware)	426-700-329
240	Door panel, size D (Panel with handles)	426-700-327
250	Door panel, size E (Panel with handles)	426-700-328
260	Display panel mounting bracket (Bracket, hardware)	383-600-264



# Replacement parts *(continued)*

Figure 110 Jacket parts



SF7010



## Replacement parts *(continued)*

Go to [www.weil-mclain.com](http://www.weil-mclain.com) to locate Weil-McLain distributors

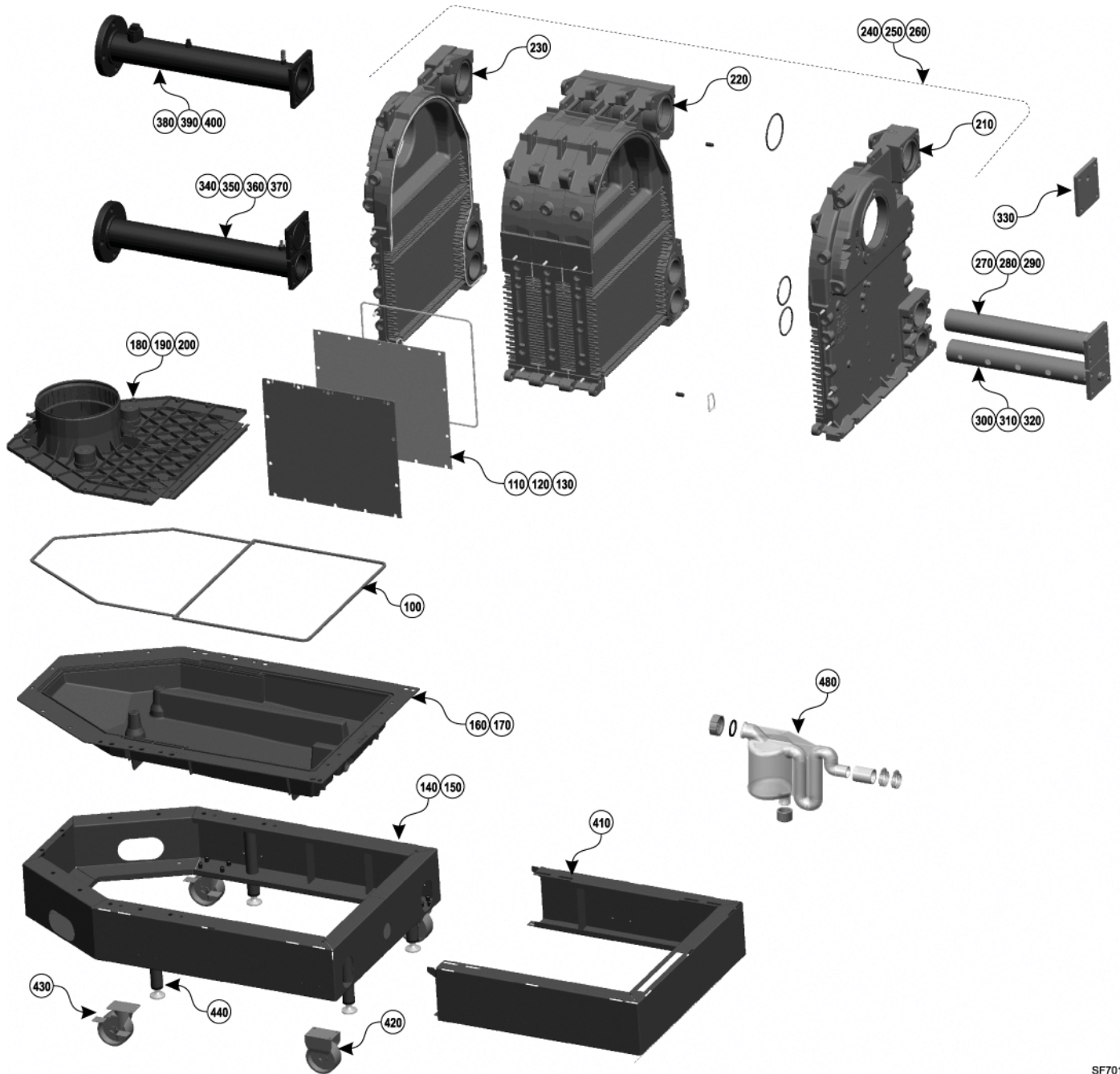
**Figure 111** Heat exchanger

Item	Description	Part Number
100	Silicone cord, 10 mm x 100 meters	383-600-201
110	Cleanout plate gasket kit, SF1000 (gasket, silicone sealing cord, hardware)	383-600-202
120	Cleanout plate gasket kit, SF1500 (gasket, silicone sealing cord, hardware)	383-600-203
130	Cleanout plate gasket kit, SF2000 (gasket, silicone sealing cord, hardware)	383-600-204
140	Bottom frame, SF1000/1500 (Frame, casters, hardware, o-ring, silicone sealing cord, silicone sealant)	383-600-205
150	Bottom frame, SF2000 (Frame, casters, hardware, o-ring, silicone sealing cord, silicone sealant)	383-600-206
160	Flue collector base kit, SF1000/1500 (Flue collector, silicone sealing cord, silicone sealant, hardware)	383-600-207
170	Flue collector base kit, SF2000 (Flue collector, silicone sealing cord, silicone sealant, hardware)	383-600-208
180	Flue collar adapter kit, SF1000 (Adapter, silicone sealing cord, gasket, o-ring, flue temperature sensor, hardware)	383-600-209
190	Flue collar adapter kit, SF1500 (Adapter, silicone sealing cord, gasket, o-ring, flue temperature sensor, hardware)	383-600-210
200	Flue collar adapter kit, SF2000 (Adapter, silicone sealing cord, gasket, o-ring, flue temperature sensor, hardware)	383-600-211
210	Heat exchanger front section (Section, silicone sealant, o-rings, hardware)	383-600-212
220	Heat exchanger intermediate sections (Section, silicone sealant, o-rings, hardware)	383-600-213
230	Heat exchanger back section (Section, silicone sealant, o-rings, hardware)	383-600-214
240	Heat exchanger, complete, assembled, SF1000	383-600-215
250	Heat exchanger, complete, assembled, SF1500	383-600-216
260	Heat exchanger, complete, assembled, SF2000	383-600-217
270	Return distribution tube, blank, SF1000 (Tube, flange, o-ring, hardware)	383-600-218
280	Return distribution tube, blank, SF1500 (Tube, flange, o-ring, hardware)	383-600-219
290	Return distribution tube, blank, SF2000 (Tube, flange, o-ring, hardware)	383-600-220
300	Return distribution tube, perforated, SF1000 (Tube, flange, o-ring, hardware)	383-600-221
310	Return distribution tube, perforated, SF1500 (Tube, flange, o-ring, hardware)	383-600-222
320	Return distribution tube, perforated, SF2000 (Tube, flange, o-ring, hardware)	383-600-223
330	Supply cover plate with LWCO port (plate, o-ring, hardware)	383-600-224
340	Return cover plate, blank (plate, o-ring, hardware) (Not shown)	383-600-228
350	Return manifold with flange, SF2000 (Manifold, flange, o-ring, temperature sensor, sealant)	383-600-229
360	Return manifold with flange, SF1500 (Manifold, flange, o-ring, temperature sensor, sealant)	383-600-276
370	Return manifold with flange, SF1000 (Manifold, flange, o-ring, temperature sensor, sealant)	383-600-277
380	Supply manifold with flange, SF2000 (Manifold, flange, o-ring, temperature sensor, sealant)	383-600-230
390	Supply manifold with flange, SF1500 (Manifold, flange, o-ring, temperature sensor, sealant)	383-600-278
400	Supply manifold with flange, SF1000 (Manifold, flange, o-ring, temperature sensor, sealant)	383-600-279
410	Bottom end rail kit	383-600-248
420	Caster kit, non-swivel (Caster, hardware)	383-600-270
430	Caster kit, swivel (Caster, hardware)	383-600-271
440	Leveling leg kit (Leveling leg, adapter)	383-600-272
460	Support frame bracket (Frame, hardware) (Not shown)	383-600-289
470	Hex head plug, 1/8 BSP, SS (Not shown)	561-431-484
480	Condensate trap coupling assembly	561-013-872



# Replacement parts *(continued)*

Figure 112 Heat exchanger



SF7011



## Replacement parts *(continued)*

Go to [www.weil-mclain.com](http://www.weil-mclain.com) to locate Weil-McLain distributors

**Figure 113** Burner, blower, venturi and gas train

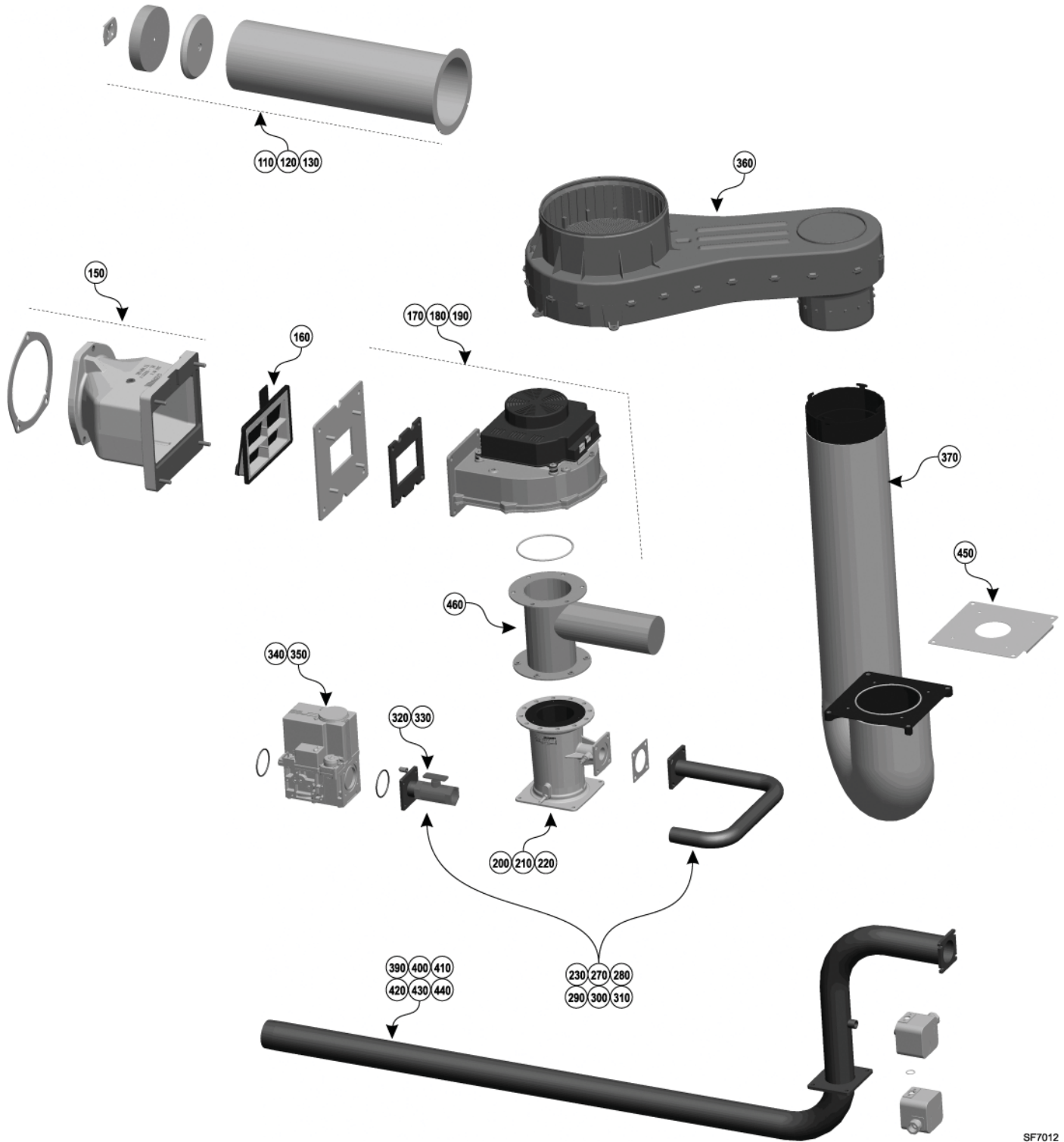
Item	Description	Part Number
100	Piping end combustion chamber access plate kit (plate, gasket, insulation, hardware) (Not shown)	383-600-231
110	Burner kit, SF2000 (burner, insulation ring, plate, hardware)	383-600-232
120	Burner kit, SF1500 (burner, insulation ring, plate, hardware)	383-600-280
130	Burner kit, SF1000 (burner, insulation ring, plate, hardware)	383-600-281
140	Burner cover plate kit (plate, insulation, hardware) (Not shown)	383-600-233
150	Mixing tube kit (Mixing tube, flapper valve, gasket, hardware)	383-600-234
160	Flapper valve kit (flapper valve, hardware)	383-600-235
170	Blower kit, SF2000 (blower, o-ring, hardware)	383-600-236
180	Blower kit, SF1500 (blower, o-ring, hardware)	383-600-282
190	Blower kit, SF1000 (blower, o-ring, hardware)	383-600-283
200	Venturi kit, SF2000 (venturi, o-ring, gasket, hardware)	383-600-237
210	Venturi kit, SF1500 (venturi, o-ring, gasket, hardware)	383-600-284
220	Venturi kit, SF1000 (venturi, o-ring, gasket, hardware)	383-600-285
230	Gas manifold, SF1000L (Manifold, gasket, manual gas valve, o-rings, hardware)	383-600-238
270	Gas manifold, SF1000R (Manifold, gasket, manual gas valve, o-rings, hardware)	383-600-239
280	Gas manifold, SF1500L (Manifold, gasket, manual gas valve, o-rings, hardware)	383-600-240
290	Gas manifold, SF1500R (Manifold, gasket, manual gas valve, o-rings, hardware)	383-600-241
300	Gas manifold, SF2000L (Manifold, gasket, manual gas valve, o-rings, hardware)	383-600-242
310	Gas manifold, SF2000R (Manifold, gasket, manual gas valve, o-rings, hardware)	383-600-243
320	Manual gas valve, T-handle, SF1000/1500	383-600-244
330	Manual gas valve, T-handle, SF2000	383-600-245
340	Automatic gas valve kit, SF2000 (Automatic valve, plastic reference line tubing, hardware)	383-600-246
350	Automatic gas valve kit, SF1000/1500 (Automatic valve, plastic reference line tubing, hardware)	383-600-286
360	Air inlet box kit (Box, hardware)	383-600-251
370	Air inlet hose kit (Hose, hardware)	383-600-252
390	Gas manifold pipe kit, SF1000L (Pipe, sealant, gasket, hardware)	383-600-291
400	Gas manifold pipe kit, SF1000R (Pipe, sealant, gasket, hardware)	383-600-292
410	Gas manifold pipe kit, SF1500L (Pipe, sealant, gasket, hardware)	383-600-293
420	Gas manifold pipe kit, SF1500R (Pipe, sealant, gasket, hardware)	383-600-294
430	Gas manifold pipe kit, SF2000L (Pipe, sealant, gasket, hardware)	383-600-295
440	Gas manifold pipe kit, SF2000R (Pipe, sealant, gasket, hardware)	383-600-296
450	Orifice plate	SF1000 383-600-301 SF1500 383-600-302 SF2000 383-600-303
460	Acoustic adapter, SF1000 only	383-600-307





# Replacement parts *(continued)*

Figure 114 Burner, blower, venturi and gas train



SF7012



## Replacement parts *(continued)*

Go to [www.weil-mclain.com](http://www.weil-mclain.com) to locate Weil-McLain distributors

**Figure 115** Controls

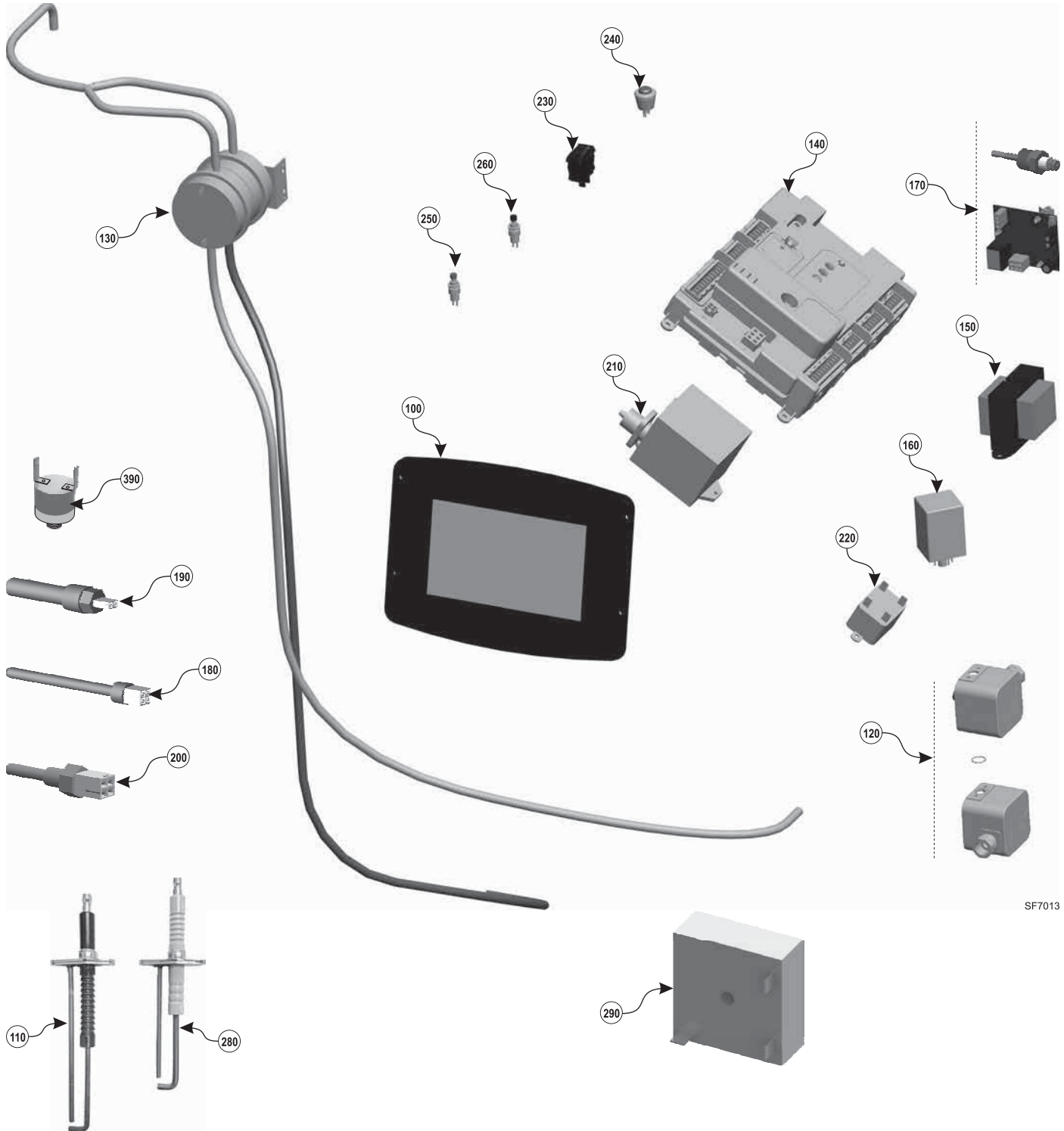
Item	Description	Part Number
100	Display panel kit	383-600-200
110	Ignitor kit (ignitor, gasket, hardware, ground harness)	383-600-226
120	Gas pressure switch kit (High/low pressure switches, hardware, sealant)	383-600-247
130	Pressure switch kit (Pressure switches, hoses, hardware)	383-600-308
140	Weil-McLain Sola control module kit (Module, hardware)	SF1000 383-600-255 SF1500 383-600-305 SF2000 383-600-306
150	Control transformer, 120/24 VAC	511-802-015
160	Blower relay (without socket)	570-350-231
170	LWCO kit (Circuit board, probe)	383-600-288
180	Flue temperature sensor kit (Sensor, gasket)	383-600-290
190	Temperature sensor, single – 1/4" NPT Return Water Sensor	571-724-295
200	Temperature sensor, dual – 1/8" NPT Supply Water Sensor	571-724-297
210	Ignition module	511-330-436
220	Minimum air flow switch relay	570-250-232
230	Boiler On/Off switch	383-500-205
240	Boiler reset switch	511-624-659
250	LWCO reset switch (red button) (part of control wiring harness)	Not available
260	LWCO test switch (black button) (part of control wiring harness)	Not available
270	Control circuit fuse (2-amp, 24-volt) (not shown) (part of control wiring harness)	591-850-191
280	Flame sensor kit	383-600-300
290	Time delay relay kit (single)	383-600-309
300	Harness-Wiring Low Water Cutoff Reset	591-391-766
310	Harness-Wiring Flame Sensor	591-391-767
320	Harness-Wiring Blower Control	591-391-768
330	Harness-Wiring Ground	591-391-770
340	Harness-Wiring Gas Pressure Switch	591-391-771
350	Harness-Wiring Main Bottom	591-391-773
360	Harness-Wiring Main Top	591-391-774
370	Harness-Wiring Auxiliary Bottom	591-391-775
380	Harness-Wiring Auxiliary Top	591-391-776
390	Heat Exchanger Thermal Switch	511-624-660

Go to [www.weil-mclain.com](http://www.weil-mclain.com) to locate Weil-McLain distributors



# Replacement parts *(continued)*

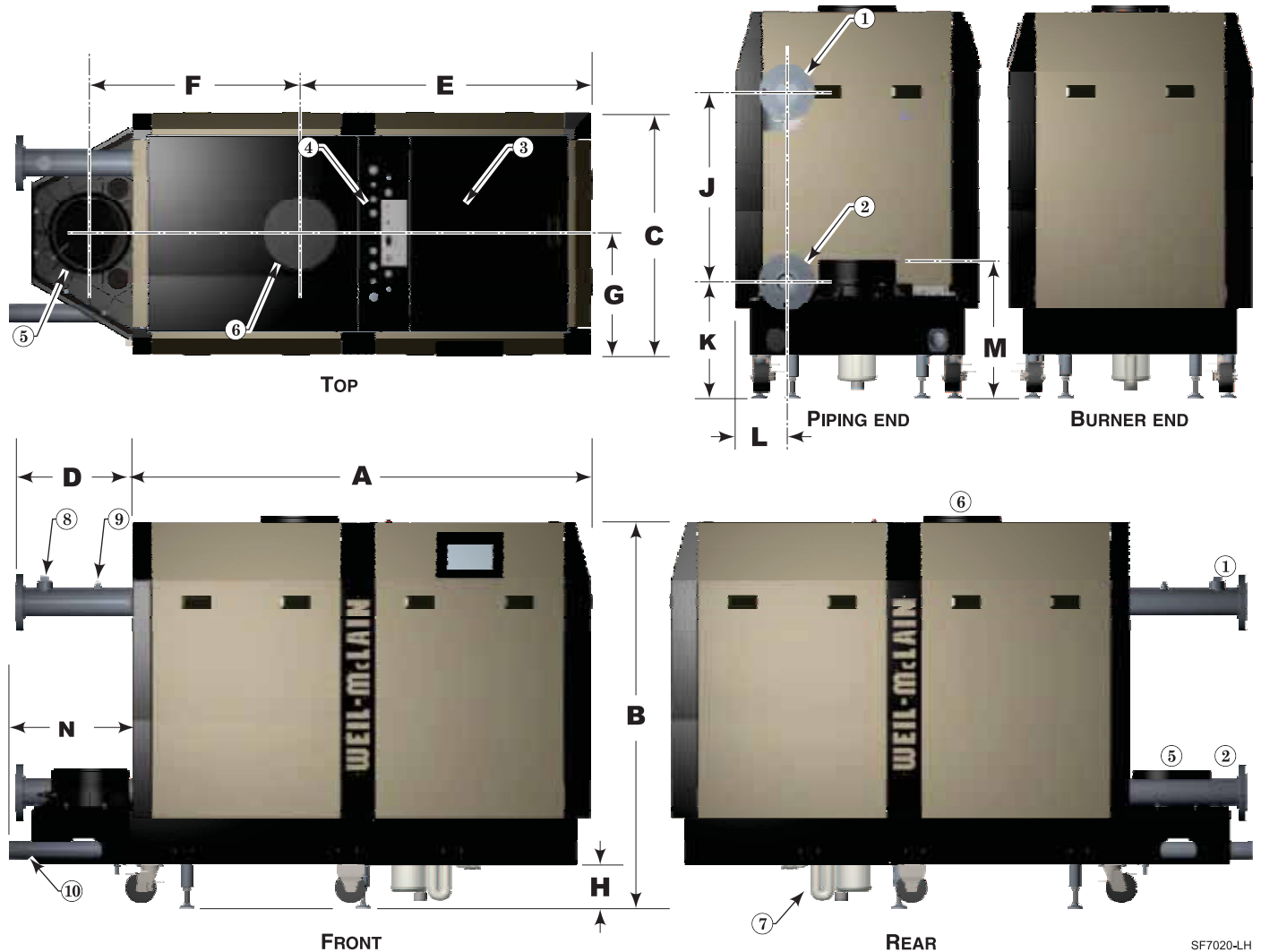
Figure 116 Controls





# Dimensions

Figure 117 Dimensional data — LEFT-HAND configuration



SF7020-LH

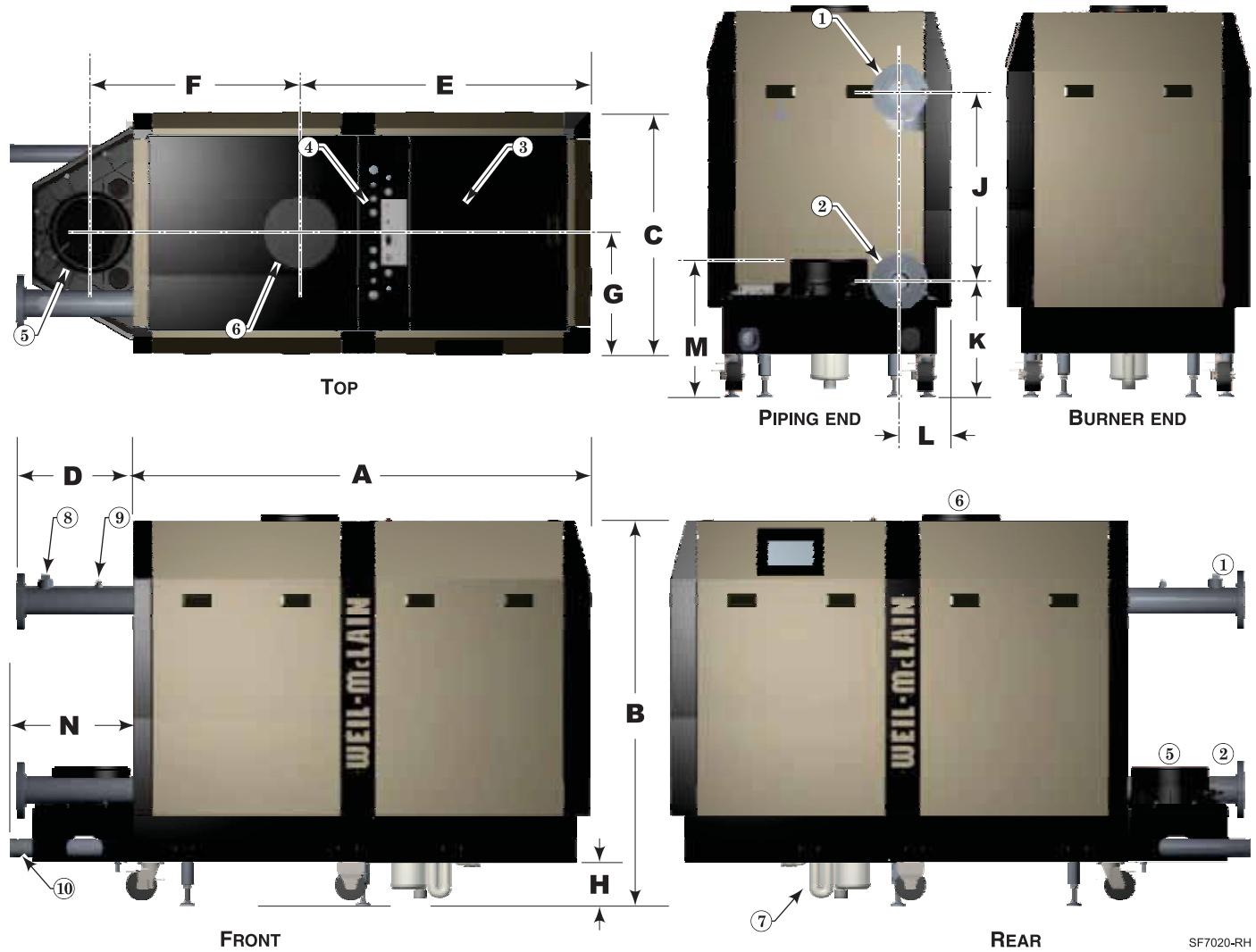
LEGEND			
<b>1</b>	Supply connection, 3" flanged	<b>5</b>	Flue connection, 10" nominal
<b>2</b>	Return connection, 3" flanged	<b>6</b>	Air connection, 10" nominal
<b>3</b>	Control panel	<b>7</b>	Condensate trap (to condensate drain)
<b>4</b>	Electrical entrance knockouts	<b>8</b>	Relief valve connection, 1½" NPT
		<b>9</b>	P/T gauge connection, ½" NPT
		<b>10</b>	Gas connection, 2" NPT

DIMENSIONS (inches) (height dimensions based on 5¼-inch spacing from floor to bottom)													
Boiler	A	B	C	D	E	F	G	H	J	K	L	M	N
SF1000	61⅜	51¼	32 <sup>9</sup> / <sub>16</sub>	15¾	39	28 <sup>1</sup> / <sub>16</sub>	16¼	5¼	25½	14 <sup>15</sup> / <sub>16</sub>	6⅞	18	16 <sup>9</sup> / <sub>16</sub>
SF1500	61⅜	51¼	32 <sup>9</sup> / <sub>16</sub>	15¾	39	28 <sup>1</sup> / <sub>16</sub>	16¼	5¼	25½	14 <sup>15</sup> / <sub>16</sub>	6⅞	18	16 <sup>9</sup> / <sub>16</sub>
SF2000	73⅝	51¼	32 <sup>9</sup> / <sub>16</sub>	15¾	39	40¼	16¼	5¼	25½	14 <sup>15</sup> / <sub>16</sub>	6⅞	18	16 <sup>9</sup> / <sub>16</sub>



# Dimensions *(continued)*

**Figure 118** Dimensional data — **RIGHT-HAND** configuration



LEGEND					
<b>1</b>	Supply connection, 3" flanged	<b>5</b>	Flue connection, 10" nominal	<b>8</b>	Relief valve connection, 1½" NPT
<b>2</b>	Return connection, 3" flanged	<b>6</b>	Air connection, 10" nominal	<b>9</b>	P/T gauge connection, ½" NPT
<b>3</b>	Control panel	<b>7</b>	Condensate trap (to condensate drain)	<b>10</b>	Gas connection, 2" NPT
<b>4</b>	Electrical entrance knockouts				

DIMENSIONS (inches) (height dimensions based on 5¼-inch spacing from floor to bottom)													
Boiler	A	B	C	D	E	F	G	H	J	K	L	M	N
<b>SF1000</b>	61¾	51¼	32 <sup>9</sup> / <sub>16</sub>	15¾	39	28 <sup>1</sup> / <sub>16</sub>	16¼	5¼	25½	14 <sup>15</sup> / <sub>16</sub>	6 <sup>7</sup> / <sub>8</sub>	18	16 <sup>9</sup> / <sub>16</sub>
<b>SF1500</b>	61¾	51¼	32 <sup>9</sup> / <sub>16</sub>	15¾	39	28 <sup>1</sup> / <sub>16</sub>	16¼	5¼	25½	14 <sup>15</sup> / <sub>16</sub>	6 <sup>7</sup> / <sub>8</sub>	18	16 <sup>9</sup> / <sub>16</sub>
<b>SF2000</b>	73¾	51¼	32 <sup>9</sup> / <sub>16</sub>	15¾	39	40¼	16¼	5¼	25½	14 <sup>15</sup> / <sub>16</sub>	6 <sup>7</sup> / <sub>8</sub>	18	16 <sup>9</sup> / <sub>16</sub>



# Ratings — SlimFit boilers

Figure 119 Ratings and engineering data



DOE



Boiler Model Number	Input		Gross Output		AHRI Ratings			Boiler Water Content	Vent/Air Pipe Size	Stack/vent flow rate	Boiler weight (pounds)		
	Btuh (Note 1)	Btuh (Note 1)	Btuh (Note 2)	Btuh (Note 2)	Net Rating	Combustion Efficiency	Thermal Efficiency				Dry weight (no water)	Operating weight (filled)	Shipping weight
					% (Note 3)	% (Note 4)	Gallons	Inches (Note 5)	scfm (Note 6)				
SF1000	1,000,000	958,000	833,000		96.1	95.8	13	6 or 8	279	865	975	1,130	
SF1500	1,500,000	1,437,000	1,250,000		95.9	95.8	19	8	418	1,050	1,210	1,310	
SF2000	2,000,000	1,906,000	1,657,000		95.8	95.3	25	8	558	1,250	1,460	1,510	

Notes	
1	Ratings shown are for seal level applications only. For altitudes above sea level, the SlimFit boiler requires no modifications and automatically de-rates itself by approximately 4% per 1,000 feet above sea level. For elevations over 5,500 feet, see the high altitude section in this manual for required control parameter changes.  The length of the vent and air piping will affect the maximum input. See Figure 120, page 126 for derate % vs vent/air piping length.
2	Net AHRI ratings are based on net installed radiation of sufficient quantity for the requirements of the building and nothing need be added for normal piping and pickup. Ratings are based on a piping and pickup allowance of 1.15. An additional allowance should be made for unusual piping and pickup loads.

Notes	
3	Combustion efficiency is based on AHRI testing procedure BTS-2000, and equal to 100% minus flue loss.
4	Thermal efficiency is based on AHRI testing procedures BTS-2000.
5	"SlimFit boilers can be direct vent or direct exhaust vented, either through a side wall or through roof, as instructed in this manual and compliant with all local codes. SlimFit Boilers require special venting, consistent with Category IV boiler. Use only the vent materials and methods identified in this manual."
6	The values are for the stack flow rate at the maximum firing rate for the given boiler. The values can vary depending on the location of the installation and operating conditions.

Figure 120 Derate due to vent/air piping length (graphs show maximum firing rate as % of rated input)

Determine vent/air piping equivalent length (feet) from Figure 27, page 30 — Use the length for L in the equations.				
Boiler	Derate % for Direct Exhaust		Derate % for Direct Vent	
	6" vent piping	8" vent piping	6" vent/air piping	8" vent/air piping
SF1000	Derate % = $0.08 \times L$ Example: If L=75 feet, Derate % = $.08 \times 75 = 6.0\%$	NOT ALLOWED	Derate % = $3.0 + (0.08 \times L)$ Example: If L=60 feet, Derate % = $3.0 + .08 \times 60 = 7.8\%$	Derate % = $0.04 \times L$ Example: If L=125 feet, Derate % = $.04 \times 125 = 5.0\%$
	NOT ALLOWED	Derate % = $0.03 \times L$ Example: If L=75 feet, Derate % = $.03 \times 75 = 2.3\%$	NOT ALLOWED	Derate % = $0.05 \times L$ Example: If L=80 feet, Derate % = $.05 \times 80 = 4.0\%$
SF1500	NOT ALLOWED	Derate % = $0.05 \times L$ Example: If L=95 feet, Derate % = $.05 \times 95 = 4.8\%$	NOT ALLOWED	Derate % = $0.07 \times L$ Example: If L=60 feet, Derate % = $.07 \times 60 = 4.2\%$
	NOT ALLOWED	NOT ALLOWED	NOT ALLOWED	NOT ALLOWED

**WARNING** Failure to follow all instructions can result in flue gas spillage and carbon monoxide emissions, causing severe personal injury or death.

**WARNING** This document must only be used by a qualified heating installer/service technician. Read all instructions, including this addendum and the Boiler Manual, before installing. Perform steps in the order given. Failure to comply could result in severe personal injury, death or substantial property damage.

**NOTICE** Installation must comply with local requirements and with the National Fuel Gas Code, ANSI Z223.1/NFPA54 for U.S. installations or CAN/CSA B149.1 for Canadian installations.





# Installation and Service Certificate

Boiler Model \_\_\_\_\_ Series \_\_\_\_\_ CP Number \_\_\_\_\_ Date Installed \_\_\_\_\_

BTU Input \_\_\_\_\_

- Installation instructions have been followed.
- Check-out sequence has been performed.
- Above information is certified to be correct.
- Information received and left with owner/maintenance person.

Installer \_\_\_\_\_

\_\_\_\_\_

(Company) (Address) (Phone) (Installer's Signature)

## START-UP DATA

High Fire CO <sub>2</sub>	%	Maximum Modulation	RPM	Low Fire CO <sub>2</sub>	%
High Fire CO	PPM	Light off rate	RPM	Low Fire CO	PPM
High Altitude	<input type="checkbox"/> No <input type="checkbox"/> Yes	Minimum Modulation	RPM		

### Parameters Changed from the Factory Default (Can also be listed on Parameter table, Figure 86 starting on page 72)

Parameter:	Changed to:	Parameter:	Changed to:	Parameter:	Changed to: