

# INSTALLATION & MAINTENANCE MANUAL PVI DURAWATT® ELECTRIC WATER HEATERS



Installation and service must be performed by a qualified service installer, service agency or qualified electrical contractor.

**IMPORTANT:** THIS MANUAL CONTAINS INFORMATION REQUIRED FOR INSTALLATION, OPERATION AND MAINTENANCE OF THIS EQUIPMENT. READ AND FOLLOW THE INFORMATION IN THIS MANUAL AND ALL OTHER PROVIDED INSTRUCTIONS, LABELS AND MARKINGS BEFORE INSTALLING, OPERATING OR SERVICING THIS UNIT.



---

**TO THE INSTALLER:** After installation, these instructions must be given to the equipment user or left near the appliance.

**SPECIAL INSTRUCTIONS TO THE OWNER:** Retain this manual for future reference. These instructions contain important information that will help you in maintaining and operating this appliance.

---



**PVi**®

PVI INDUSTRIES, LLC - Fort Worth, Texas 76111 - [www.pvi.com](http://www.pvi.com) - 1-800-433-5654

# DURAWATT® ELECTRIC WATER HEATERS

## TABLE OF CONTENTS

- 1. Safety Considerations**
- 2. Product Descriptions**
- 3. Water Heater Installation**
  - 3.1 Checking Equipment Before You Install
  - 3.2 Codes
  - 3.3 Electrical Requirements
  - 3.4 Location
  - 3.5 Installation
  - 3.6 Service Clearances
  - 3.7 Clearances to Combustible Surfaces
  - 3.8 Electronic Low Water Cutoff
- 4. Optional Equipment**
  - 4.1 Shunt Trip Circuit Interrupter
  - 4.2 Time Sequencer
  - 4.3 Proportional Sequencer
- 5. Start-up Procedures and Operation**
- 6. Element Continuity Checks**
- 7. Maintenance**
  - 7.1 Flushing
  - 7.2 Draining the Tank
  - 7.3 Sediment / Lime Scale Removal
  - 7.4 T&P Relief Valve
  - 7.5 Low Water Cutoff
  - 7.6 Electrical Connections
  - 7.7 Replacing Electric Elements
  - 7.8 Cleaning Electric Elements
- 8. Troubleshooting Guide**

**Warranty forms ship separately with each product.**

# DURAWATT® ELECTRIC WATER HEATERS

## 1 SAFETY CONSIDERATIONS

**WARNING: If the information in the supplied manual(s) is not followed exactly, a fire, electrical short or exposure to hazardous materials may result, causing property damage, personal injury or loss of life.**

### FOR YOUR SAFETY

- Do not store or use gasoline or other flammable vapors or liquids in the vicinity of this or any other appliance.

### WHAT TO DO IF YOU SMELL GAS

- Do not try to light any appliance.
- Do not touch any electric switch; do not use any phone in your building.
- **Immediately** call your gas supplier from a location away from your building and the smell of gas. Follow the gas supplier's instructions.
- If you cannot reach your gas supplier, call the fire department.

Installation and service must be performed by a qualified installer, service agency or qualified electrical contractor.

**WARNING: Installation and service must be performed by a qualified installer, service agency or qualified electrical contractor, who must read and follow the supplied instructions before installing, servicing or removing this appliance. Refer to the information contained in this manual. Improper installation, adjustment, alteration, service or maintenance can cause property damage, personal injury, exposure to hazardous materials or loss of life.**

**WARNING: Do not use this appliance if any part has been under water. Immediately call a qualified service technician to inspect the unit and to replace any part of the control system, all controls and all other items affecting safe appliance operation and which has been under water.**

**WARNING: In an emergency disconnect all electrical power to the appliance from a location safely away from the emergency. Failure to follow these instructions can cause property damage, personal injury, and exposure to hazardous materials or loss of life.**

# DURAWATT® ELECTRIC WATER HEATERS

## IMPORTANT SAFETY NOTE

*It takes only 5 seconds of skin contact with 140°F water to cause a second degree burn! You must protect against high water temperatures at all lavatories, tubs, showers and other points of hot water contact.*

**Accidental scalding from high water temperatures is a greater risk in some types of installations. Some examples are:**

**HOMES FOR THE MENTALLY HANDICAPPED  
HOMES FOR THE PHYSICALLY HANDICAPPED  
HOSPITALS AND NURSING HOMES  
ELDER CARE FACILITIES AND REST HOMES  
ORPHANAGES AND CHILD CARE FACILITIES**

**OTHER INSTALLATIONS - WHERE RESPONSE TO CONTACT WITH HOT WATER MAY BE SLOWER OR WHERE THE DANGER OF HOT WATER CONTACT IS GREATER**

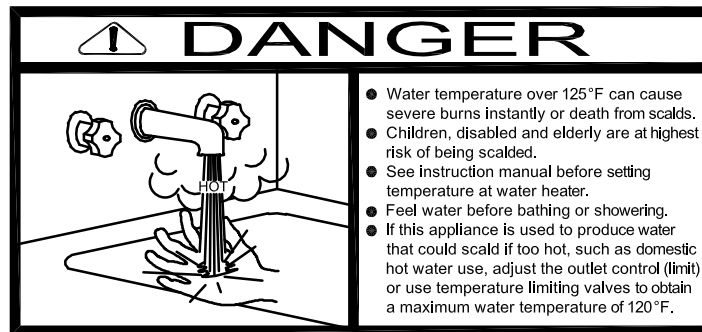

**Thermostatically controlled mixing valves must be used in the design of the potable hot water system.**

**Potable hot water should be tempered to no more than 110°F when used for bathing or other personal uses.**

**Good engineering practice mandates the use of thermostatically controlled mixing valves set at 120°F or less to keep the delivered water temperature below scalding temperatures.**

# DURAWATT® ELECTRIC WATER HEATERS

## 2 PRODUCT DESCRIPTIONS

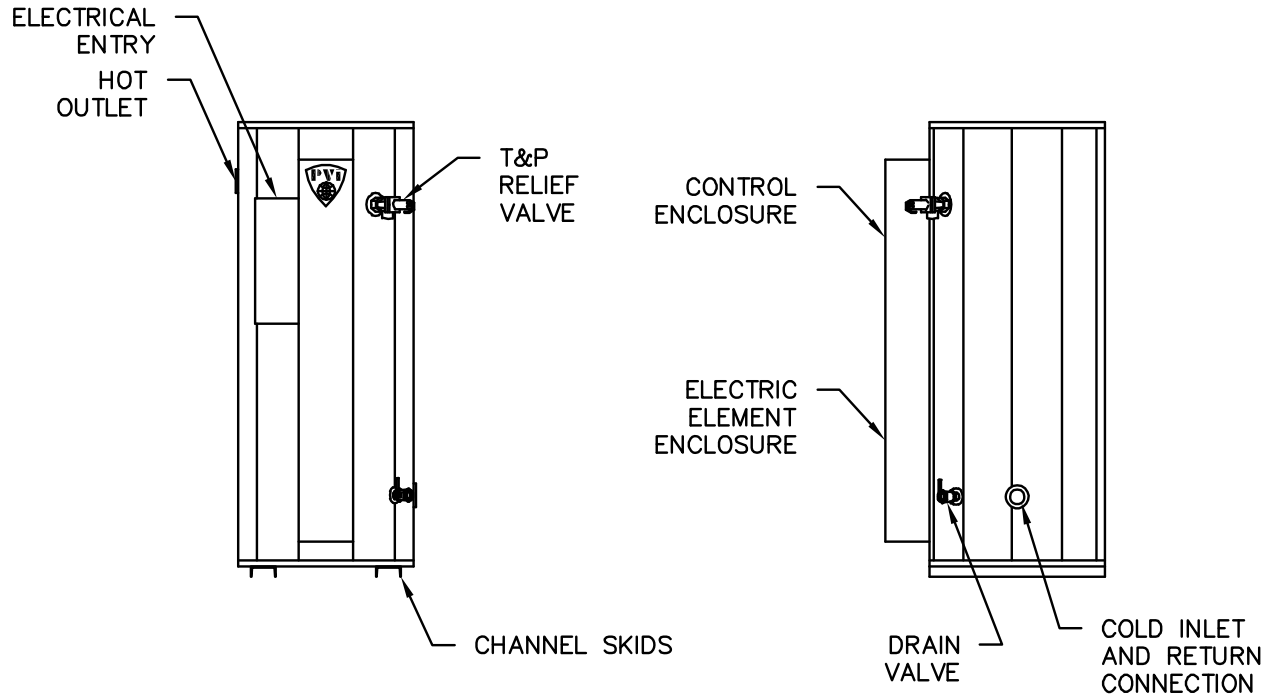

**Without 23" Diameter Tank Access**  
FIGURE 1

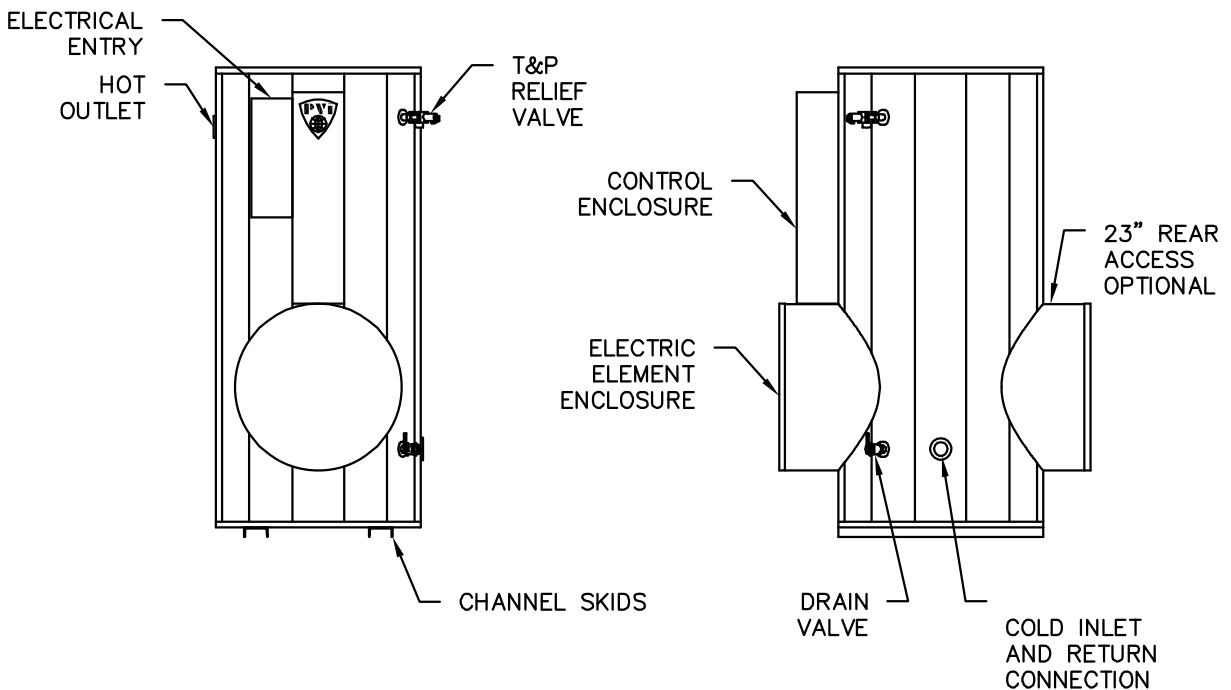

**With 23" Diameter Tank Access**  
FIGURE 2

# DURAWATT® ELECTRIC WATER HEATERS

## 3 WATER HEATER INSTALLATION

### 3.1 Checking Equipment Before You Install

Inspect the unit completely upon receipt from the freight carrier before signing the bill of lading. Inspect the appliance and all accompanying parts for signs of impact or mishandling. Verify the total number of pieces shown on packing slips with those actually received. Contact the freight carrier immediately if any damage or shortage is detected.

### 3.2 Codes

The equipment must be installed in accordance with those installation regulations in force in the local area where the installation is to be made. Authorities having jurisdiction must be consulted before installation is made. In the absence of such requirements, the installation shall be in accordance with the instructions in this manual, appliance markings and supplemental instructions and in compliance with the latest edition of the National Electrical Code, NFPA-70. Where required by the Canadian authority having jurisdiction, the equipment must be installed in accordance with the latest edition of the Canadian Electrical Code, C22.1 and applicable provincial regulations. All appliances conform to the current edition of the ASME Boiler and Pressure Vessel Code, Section IV, Part HLW or Section VIII.

### 3.3 Electrical Requirements

1. Check rating plate on front for correct voltage, phase and amperage. Refer to the wiring diagram for control components mounted on the heater.
2. Use proper wire size and branch circuit protection as required by the latest edition of the National Electrical Code, NFPA-70 and state and local codes or in Canada, as required by the latest edition of the Canadian Electrical Code, C22.1 and provincial and local codes. The PVI electric water heater specification sheets show the number and size of power connectors furnished with the heater for minimum 90°C copper connecting wire.
3. Use proper wire size for the ground connection. Attach to the bottom ground terminal connection on the terminal block assembly marked with decal "GR".
4. Connect supply feeders to the distribution block (or circuit interrupter if furnished) inside the electrical enclosure on the heater.

**IMPORTANT:** Check all wiring connections in heater and element enclosure to assure tightness prior to energizing.

**NOTE:** Use only copper wire of proper sizing for incoming service. Damage resulting from use of aluminum wiring is excluded from coverage under the warranty of this unit.

Utiliser du fil de cuivre de la taille appropriée pour le service électrique entrant. Les dommages résultant de l'utilisation de fil d'aluminium seront exclus du champ d'application de la garantie de cet appareil.

### 3.4 Location

1. Locate the unit in a clean and dry area as close as possible to the greatest hot water usage and as near to electrical power as practical.
2. Install the unit on a firm, level foundation.
3. Locate the foundation on a pitched floor near a suitable drain, or make other provisions to prevent contact to areas of the building subject to water damage should the water heater or a water connection leak. The drain must be sufficient to contain water in excess of 210°F.

### 3.5 Installation

**WARNING: Use industry standard safe rigging methods when attempting to lift or move this product. Failure to follow these instructions could result in property damage, serious injury or death. One common method includes the use of straps and spreader bars, lifting from the water heater base skid assembly.**

1. Check the data decal on the heater. Be sure the electrical supply is adequate for the installation.
2. Carefully remove all shipping supports and bracing. (Float type devices have shipping plugs blocking the float).
3. Install shut-off valves and unions on the inlet and outlet water piping for servicing. Use caution when threading pipe nipples into tank connections to prevent cross threading, or over-tightening. Always use a back-up wrench on tank nipples when tightening unions, valves, etc.

# DURAWATT® ELECTRIC WATER HEATERS

4. Insulate hot water and return circulation lines. Also, if subject to freezing during shutdown or during operation, insulate all water piping and take whatever steps are necessary to keep the appliance and all water containing pipes and components from freezing. **IMPORTANT:** Do not use the plumbing connected to the appliance as a ground for welding or any other purpose.
5. The water heater is equipped with a temperature and pressure relief valve(s) rated for the input. Pipe the relief valve discharge to a suitable open drain. The drain pipe may not be smaller than the relief valve opening and must be secured to prevent it from lifting out of the drain under discharge pressure. Do not install valves or restrictions in the discharge line.
6. Pipe the drain valve to a suitable open drain.

## 3.6 Service Clearances

Allow sufficient space to provide adequate clearances on all sides for service and inspection. Recommended clearance is 24" at the top and front, 18" at left and right sides of the appliance. Optional equipment may increase the clearance requirements. Allow sufficient space for installing and servicing connections such as water, electrical, pump and other auxiliary equipment.

## 3.7 Clearances to Combustible Surfaces

The appliance must not be installed on a combustible floor, or on a non-combustible floor covering combustible material. The minimum clearance to combustible material is 6" from the top, sides and rear, and 24" from the front.

Distance minimale aux matériaux combustibles est de 15 cm sur le dessus, les côtés et à l'arrière et 61 cm à l'avant et ne doit pas être installé sur un plancher combustible.

## 3.8 Electronic Low Water Cutoff

The device consists of a probe in the tank that acts as a switch, open when submerged in water and closed when the water level is below the probe, preventing heating elements from energizing. The probe should be kept free of scale buildup to insure operation.

## 4 OPTIONAL EQUIPMENT

- 4.1 **Shunt Trip Circuit Interrupter** (optional on all models): The shunt trip, wired in the non-automatic circuit interrupter, is a safety device designed to open the circuit interrupter and prevent the elements from energizing if the control panel door is opened.
- 4.2 **Time Sequencer** (optional on all models): Time sequencing is optional and used in lieu of the proportional sequencer. It is a series of time delay relays wired to the contactors which allows approximately a 40 second delay in energizing each succeeding heating element when the controls call for heat. This prevents all heating elements from energizing at the same time.
- 4.3 **Proportional Sequencer** (optional on all models): Progressive sequencing (orbital) equalizes the on time for each contactor and heating element. The heating elements are staged-on based on the demand on the water heater. The control gives visual, indication of stages that are on. In the event of power interruption, all contactors are turned off. When power is resumed, the control will re-stage the elements beginning with number one.

# DURAWATT® ELECTRIC WATER HEATERS

## 5 START-UP PROCEDURES AND OPERATION

**WARNING:** Turn off all electrical service to the appliance when accessing the controls located inside the control cabinet. The cabinet contains high voltage wiring and terminals. If the electrical service is not turned off and these wires or terminals are touched, a dangerous shock causing personal injury or loss of life could occur. Close the control cabinet before restoring electrical service to the appliance.

**Coupez l'alimentation avant intervention sur l'appareil.**

1. Use multimeter to check resistance to ground between all element terminals and the element mounting flange. (See table 1)

Fill the heater with water. Open the relief valve to allow air in the tank to escape. Be sure all connections into the tank are tight as leaks at tank fittings or heating elements can cause damage.

Check inside of electrical enclosure for leaks with tank full of water at water line pressure. Heating element gaskets are pressure tested at factory but may leak if unit has been in dry storage for a long period of time.

If leaks are present, tighten all four nuts uniformly on the element mounting flange in a criss-cross pattern. Tighten one nut, then the nut on the diagonal from the first nut. Next, tighten the nut adjacent to the second nut, and then the nut diagonal from the third nut. Repeat this sequence until all nuts are tight. Each nut should be tightened to 15 foot pounds of torque. To avoid warping the flange, do not over tighten.

**IMPORTANT:** All leaks must be corrected prior to turning on electricity to avoid damage to electrical components within the enclosure.

**Electric element (design may vary): 3 phase elements have 3 terminals; 1 phase elements have 6 terminals.**

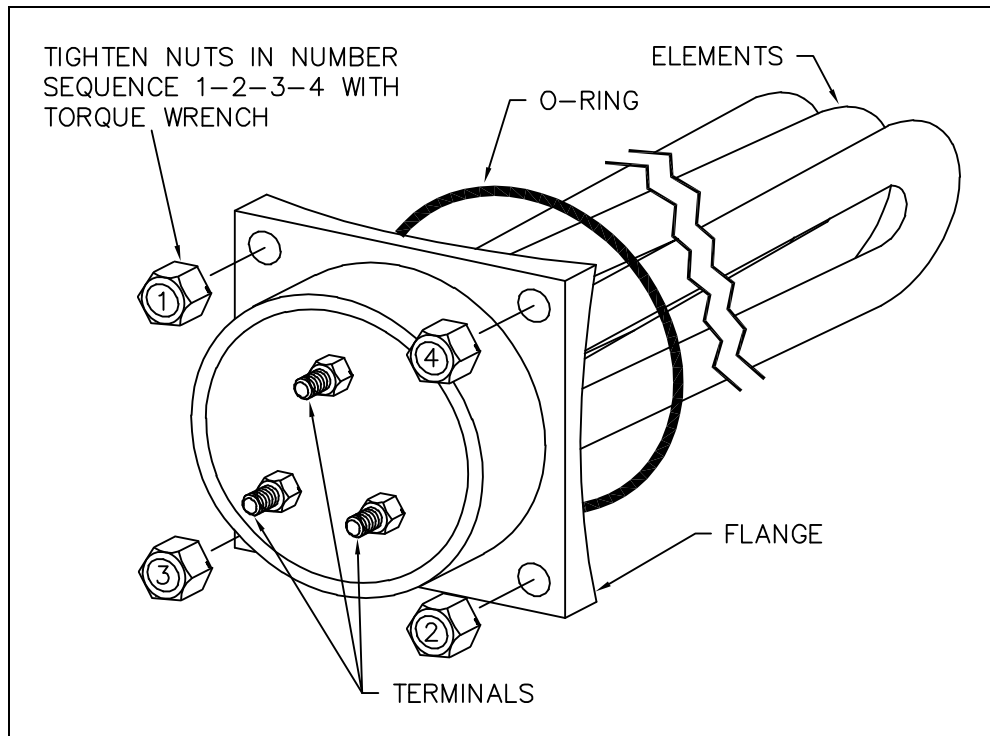

FIGURE 3

2. The tank must be full of water before turning on electricity. If elements are energized without water in the tank, they will burn out immediately. Warranty is void on dry starts.
3. Check all electrical connections for tightness before turning the unit on.
4. Energize manual disconnect switch. Check for proper voltage (with voltmeter) on power circuit. Voltage should not vary more than 5% from voltage shown on data plate. If voltage exceeds these limits, immediately turn off main disconnect and contact utility company.
5. Energize control circuit switch. Check for proper voltage.



## DURAWATT® ELECTRIC WATER HEATERS

6. Check for proper amperage with ammeter on power circuit. Amperage should not vary more than 5%, when under full load, from amperage shown on data plate. (Table 2). If amperage exceeds these limits, immediately turn off main manual disconnect and refer to Electric Water Heater Trouble Shooting Guide.
7. Check magnetic contactors for noise. If noisy, i.e., buzzing or chattering, turn off main power disconnect, disassemble contactor and blow out foreign particles. Drill filings, dirt or other particles can cause pitting of points which will in turn burn out contactor and/or wire. Extra care has been taken during fabrication and inspection for cleanliness; however, field installation is often responsible for debris collecting on the contactor points.
8. The top thermostat is a temperature limiting safety device set at 200°F. The upper operating thermostat is factory set at 130°F. The lower operating thermostat is set at 120°F Adjust stored water temperature by turning the Operating thermostat dial to the desired temperature. The Upper Operating and Operating thermostats should be set minimum 10°F higher.

Le thermostat est réglé à environ 49 degrés Celsius. Températures de l'eau supérieures à 52 degrés Celsius peut causer instantanément de graves brûlures ou la mort de brûlures. Suivez les instructions dans le manuel d'installation et de maintenance pour modifier la température de l'eau.

9. If an optional proportional sequencer is furnished, adjust set point to desired water temperature. (All other temperature controls must be set above the sequencer's set point.) Refer to manufacturer's product literature for servicing, operation and maintenance of proportional sequencer.
10. After startup and with the water heater operating, allow the water in the tank to reach the desired temperature and de-energize the heating elements. Draw hot water from a nearby faucet or outlet until the heating elements come back on. This will check for proper operation of the thermostats and other operating controls.

**IMPORTANT:** After approximately 30 minutes of operation, turn off all power to the unit. With main disconnect off, check each wire connection and fuse clip for elevated temperature. If an elevated temperature is noted, there is a loose connection at the point of greatest heat. All connections must be tight for proper performance.

# DURAWATT® ELECTRIC WATER HEATERS

## 6 ELEMENT CONTINUITY CHECKS

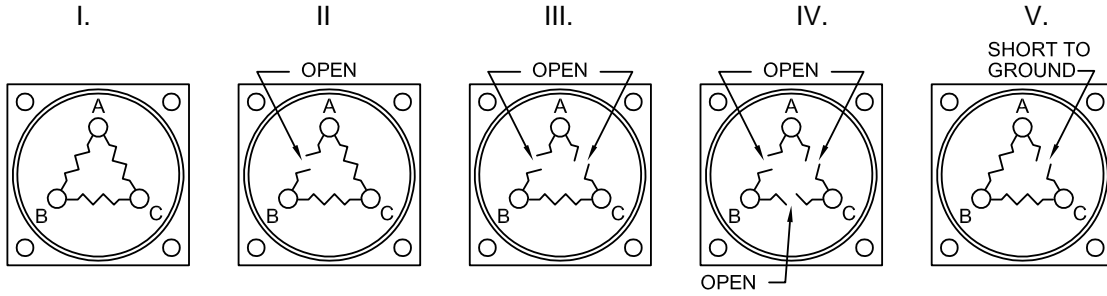

NOTE: ELEMENT WIRE LEADS MUST BE DISCONNECTED TO PREVENT FALSE OHM READINGS.

ELEMENT RATING		CHECK OPEN COILS	I.	II.	III.	IV.	V.
kW	VOLT		OHM READING NORMAL	OHM READING 1 LEG OPEN	OHM READING 2 LEGS OPEN	OHM READING 3 LEGS OPEN	OHM READING TERMINAL TO FLANGE
18	600	A-B	40	120	∞	∞	Depending on the severity of the short, the OHM reading may vary from zero, (direct short) to several hundred ohms (partial short). In any case where the OHM reading is not infinity, the element should be replaced.
		B-C	40	60	60	∞	
		C-A	40	60	∞	∞	
18	480	A-B	26	78	∞	∞	
		B-C	26	39	39	∞	
		C-A	26	39	∞	∞	
18	380	A-B	17	50	∞	∞	
		B-C	17	25	25	∞	
		C-A	17	25	∞	∞	
18	240	A-B	7	20	∞	∞	
		B-C	7	10	10	∞	
		C-A	7	10	∞	∞	
18	208	A-B	6	16	∞	∞	
		B-C	6	8	8	∞	
		C-A	6	8	∞	∞	
9	600	A-B	80	240	∞	∞	
		B-C	80	120	120	∞	
		C-A	80	120	∞	∞	
9	480	A-B	52	154	∞	∞	
		B-C	52	77	77	∞	
		C-A	52	77	∞	∞	
9	380	A-B	33	98	∞	∞	
		B-C	33	49	49	∞	
		C-A	33	49	∞	∞	
9	240	A-B	14	40	∞	∞	
		B-C	14	20	20	∞	
		C-A	14	20	∞	∞	
9	208	A-B	10	30	∞	∞	
		B-C	10	15	15	∞	
		C-A	10	15	∞	∞	
4.5	600	A-B	160	480	∞	∞	
		B-C	160	240	240	∞	
		C-A	160	240	∞	∞	
4.5	480	A-B	103	308	∞	∞	
		B-C	103	154	154	∞	
		C-A	103	154	∞	∞	
4.5	380	A-B	65	194	∞	∞	
		B-C	65	97	97	∞	
		C-A	65	97	∞	∞	
4.5	240	A-B	26	78	∞	∞	
		B-C	26	39	39	∞	
		C-A	26	39	∞	∞	
4.5	208	A-B	20	58	∞	∞	
		B-C	20	29	29	∞	
		C-A	20	29	∞	∞	

TABLE 1

### TYPICAL CURRENT MEASUREMENTS

# DURAWATT® ELECTRIC WATER HEATERS

## TYPICAL SINGLE PHASE WIRING

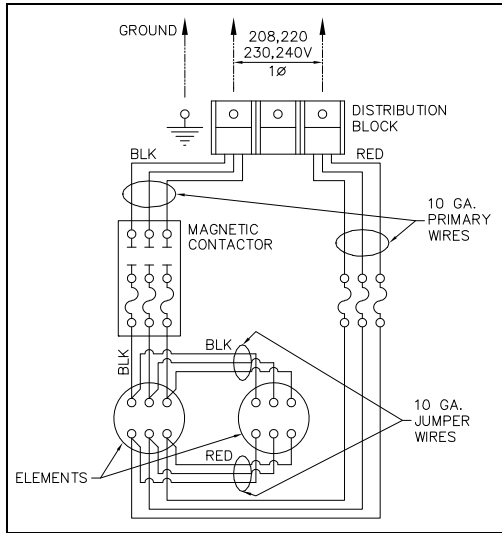

FIGURE 4

## TYPICAL THREE PHASE WIRING

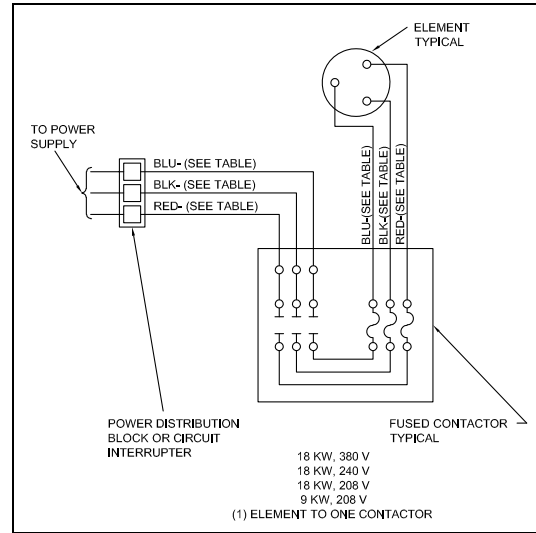

FIGURE 6

## TYPICAL WIRE TERMINATIONS

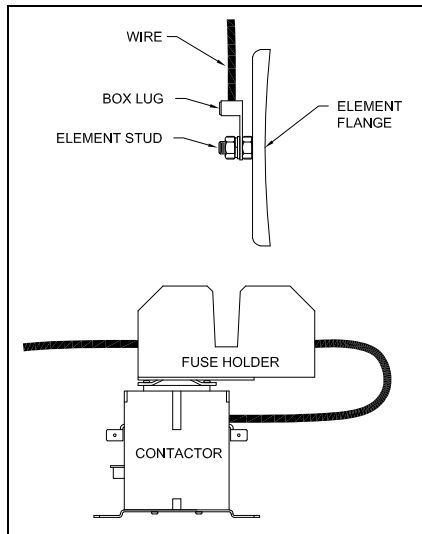

FIGURE 5

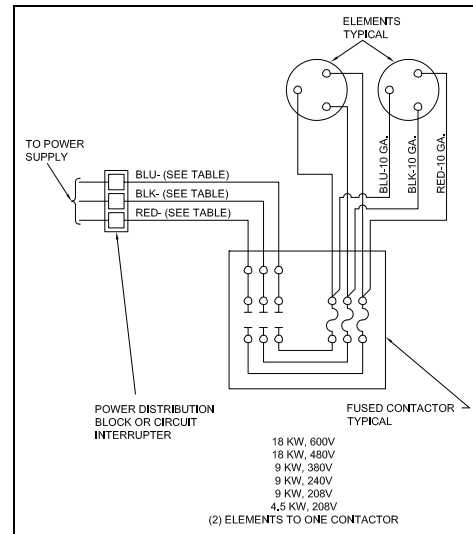

FIGURE 7

REQUIRED WIRE SIZE	
Contactor Fuseholder	Wire Size
600V – 30A	10 AWG
300V – 60A	6 AWG
600V – 60A	6 AWG

TORQUEING REQUIREMENTS		
Wire Size	Terminal Type	In-lbs
10 AWG	RING	25
10 AWG	BOX	35
6 AWG	BOX	45

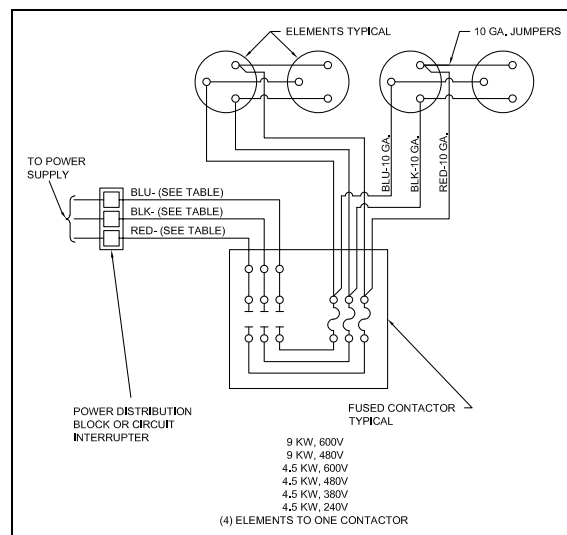

FIGURE 8

# DURAWATT® ELECTRIC WATER HEATERS

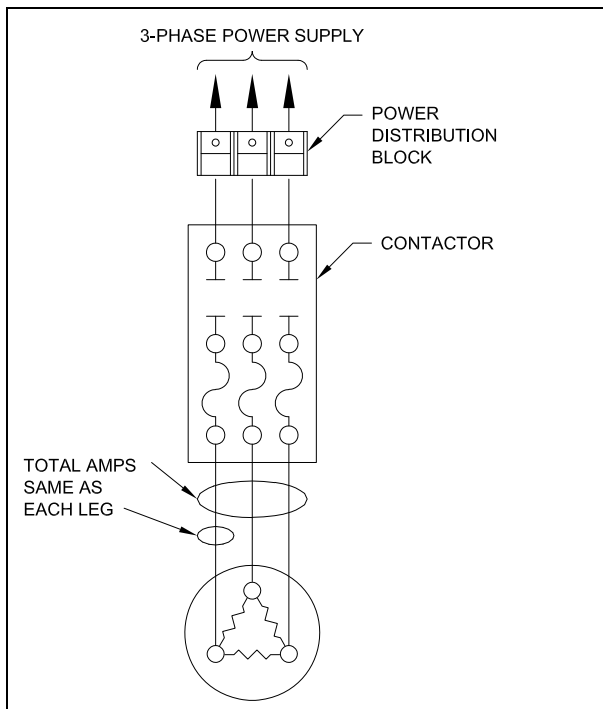

FIGURE 9

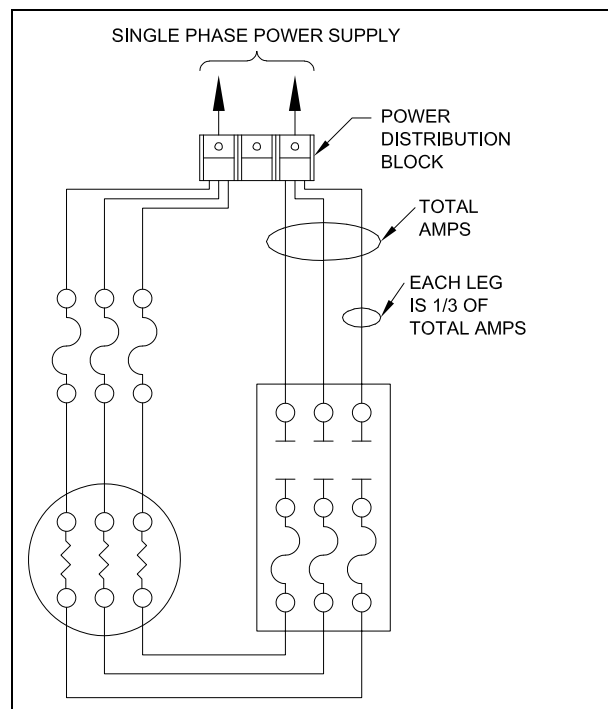

FIGURE 10

KW-VOLTAGE	3 Ø AMPS PER ELEMENT		1 Ø AMPS PER ELEMENT	
	AMPS PER LEG	AMPS TOTAL	AMPS PER LEG	AMPS TOTAL
*14 kW-600V	13 1/2	13 1/2	—	—
*7 kW-600V	7	7	—	—
18 kW-600V	18	18	—	—
9 kW-600V	9	9	—	—
4.5 kW-600V	4 1/2	4 1/2	—	—
18 kW-480V	22	22	—	—
9 kW-480V	11	11	—	—
4.5 kW-480V	5 1/2	5 1/2	—	—
18 kW-380V	28	28	—	—
9 kW-380V	14	14	—	—
4.5 kW-380V	7	7	—	—
18 kW-240V	44	44	25	75
9 kW-240V	22	22	13	38
4.5 kW-240V	11	11	6	18
18 kW-208V	50	50	29	87
9 kW-208V	25	25	15	44
4.5 kW-208V	12 1/2	12 1/2	7	22

TABLE 2

**NOTE:** Elements are usually wired to contactors in groups, in order to maintain an amperage draw of close to, but not more than, 50 amps per contactor.

\*Applications for 600V may be a re-rated 480V element. Therefore, the 40W/in.<sup>2</sup> may be rated for 14 kW instead of 9 kW.

# DURAWATT® ELECTRIC WATER HEATERS

## 7 MAINTENANCE

A preventative maintenance program is required to ensure a long trouble-free life of the water heater.

### Maintenance Schedule

COMPONENT	OPERATION	INTERVAL	REQUIRED
Tank	Sediment Removal	Every 3 Months	Flushing
Relief Valve	Inspect	Every 6 Months	Test
Electrical Connections	Inspect	Monthly	Inspect for wire discoloration
Electric Elements	Check	Every 6 Months	Amp Draw
Electric Elements	Remove & Clean	See Page 9	

### 7.1 Flushing

1. Turn off the heater electrical disconnect switch.
2. Open the drain valve and allow water to flow until it runs clean.
3. Close the drain valve when finished flushing.
4. Turn on the heater electrical disconnect switch.

### 7.2 Draining the Tank

The heater must be drained if it is to be shut down and exposed to freezing temperature. Maintenance and service procedures may also require draining the heater.

1. Turn off the heater electrical disconnect switch.
2. Close the cold water inlet and hot water outlet valve to heater.
3. Open a relief valve to vent the tank pressure.
4. Open the heater drain valve.
5. If the heater is being drained for an extended shutdown, it is suggested the drain valve be left open during this period.

### 7.3 Sediment / Lime Scale Removal

Waterborne impurities consist of the particles of soil and sand which settle out and form a layer of sediment on the bottom of the tank and adhere to heat exchange surfaces. The amount of calcium carbonate (lime) released from water is in direct proportion to water temperature and usage. The higher the water temperature or water usage, the more lime deposits are dropped out of the water. Lime accumulation not only reduces the life of the equipment but also reduces efficiency of the heater.

### 7.4 Temperature and Pressure Relief Valve

The relief valve should be checked at regular intervals by manually opening the valve. The openings inside the valve may become restricted by a buildup of scale and become inoperative. If the valve does not open and close properly and does not blow off internal pressure when tested, it must be replaced. Shut down heater, relieve internal pressure and replace relief valve with a like kind or one meeting the requirements stated on the rating decal located adjacent to the relief valve mounting location.

### 7.5 Low Water Cutoff

The standard low water control is electronic. Inspection should be made of the electrode on water heaters equipped with electronic low water devices.

# DURAWATT® ELECTRIC WATER HEATERS

## 7.6 Electrical Connections

Check all electrical connections approximately one to two weeks after initial start-up to assure tightness. Heating and cooling from operation can loosen connections. Visually inspect wire terminal points for any discoloration on a monthly basis. Discoloration is likely due to a loose connection at the point nearest discoloration. Check contactors periodically and clean if necessary and repair or replace pitted points caused by foreign particles. Check fuses periodically for continuity and replace if necessary with the same type and rating.

## 7.7 Replacing Electric Elements

Some electric heating elements installed in dished heads may be factory bent to allow clearance from adjacent elements. Replacement elements must be identical to the original equipment installed. The **Bend Angle Stamp #** is required for all replacement electric element requests.

**IMPORTANT:** Install the element facing away from the center of the head.

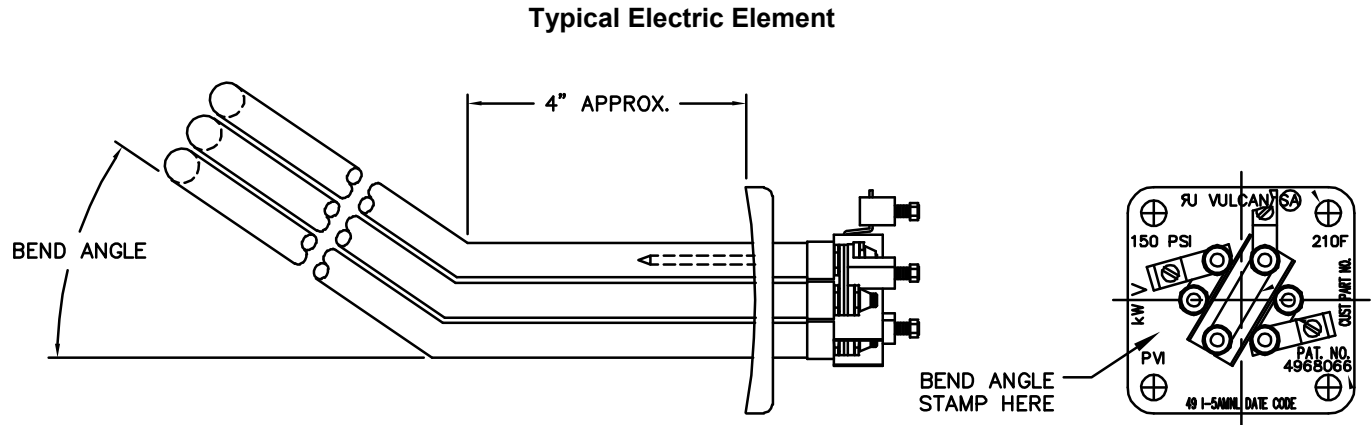

BEND ANGLE	STAMP
25°	#1
18°	#2

FIGURE 11

**NOTE:** No stamp on the element flange means that the element is not bent.

# DURAWATT® ELECTRIC WATER HEATERS

## 7.8 Cleaning Electric Elements

Electric immersion INCOLOY® sheath elements are wound at high wattage ratings and must be completely covered by water while in operation. Otherwise, they overheat and burn out. Scale from the water will collect on the sheathing of the element over a period of time and must be removed periodically to extend the life of the element. Water in some areas will produce the scale buildup more rapidly than other areas. The rapidity of the scale buildup is also determined by the watt density of the element.

It is good maintenance practice to remove and clean 80 W/in<sup>2</sup> (18kW) density elements on a monthly basis. The interval between removal and cleaning can usually be extended to six months when 40 W/in<sup>2</sup> (9kW) density elements are installed. Most installations where 20 W/in<sup>2</sup> (4 1/2kW) density elements are used, require only annual cleaning. Elements are cleaned by soaking in a scale dissolving solution. A 30" piece of four or six inch PVC pipe with a cap on one end makes an ideal container for element cleaning. (See figure 12.) Contact a chemical supply house for advice on the proper cleaning solution for your area.

**Element Cleaner**

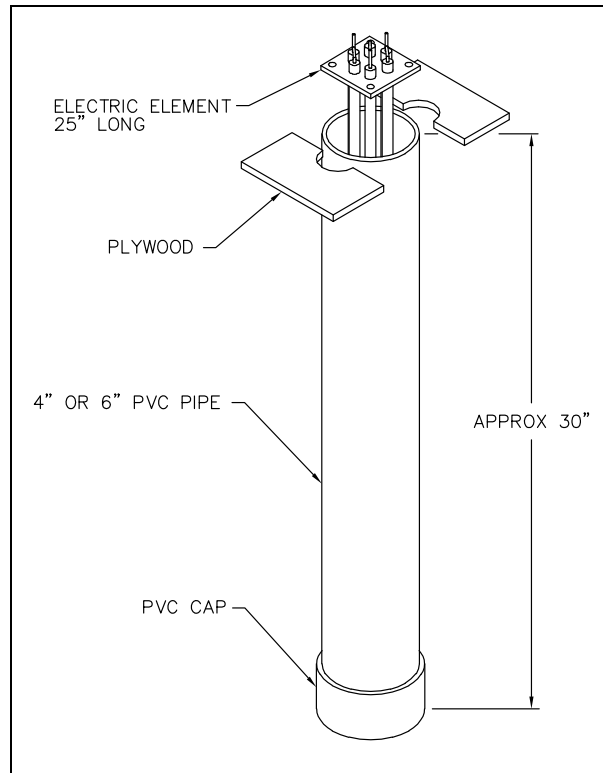

**FIGURE 12**

# DURAWATT® ELECTRIC WATER HEATERS

## 8 TROUBLESHOOTING GUIDE

PROBLEM	PROBABLE CAUSE	CORRECTIVE ACTION
<b>No hot water</b>	Thermostat(s)	Check to assure proper thermostat setting.
	Contactors will not pull in	Check continuity between all three thermostats or pressure controls. Complete circuit. If one is open, it must be replaced.
	Control circuit switch is in OFF position	Close switch. (Turn to ON position)
	Control circuit fuse blown	Isolate cause for failure and replace fuse.
	Contactor(s) coil open	Check continuity. Replace coil if not a complete circuit.
	Time delay sequencer not operating	Check for 120 volts to coil on first sequencer step. Allow ample time for additional steps to energize. If steps do not energize in reasonable time, replace only the defective relay step. See wiring diagram.
	Proportional sequencer not operating	Check for 120 volts to line connection (L) on sequencer. Check fuse for continuity. See wiring diagram. Consult factory.
	Low water cutoff closed	Check for open circuit. Check water level in tank. Replace low water cutoff if defective.
	Heating elements	Check for open legs. (See table 2).
<b>Insufficient hot water</b>	Heater not large enough to satisfy peak demands	Add booster or additional kw input. Consult local PVI representative.
	Hot water lines not insulated	Add insulation; it will protect against heat loss and save on cost of operation.
	Power fuse(s) blown	Check fuses for continuity. Replace if blown. If blown, determine cause of break before replacing with same type fuse.
	Contactor(s) not closing	Check coil for continuity. If defective, replace.
	Thermostat(s) not correctly set	Check to assure proper thermostat control setting.
	Element(s) not heating	Check for proper amperage draw. Check for proper ohm resistance. Replace if defective. Consult factory. (See table 1)
<b>Burned or discolored wires</b>	Loose connections	Tighten all connections. If charred, replace wire with wire of same type and size.
	Dirty or pitted contactor points	Remove contactor points and inspect. If dirty, clean with emery paper. <b>CAUTION: Point must remain flat. If pitted or burned, contactor points must be replaced.</b>
<b>Blown fuses</b>	Loose connection. Defective element	Check all connections for tightness. Check ohm resistance in electric elements. Replace.
<b>High or low voltage</b>	Local utility	Check with local utility.
<b>High or low amperage</b>	High or low voltage. Defective element	Check with local utility. Low amperage, check fuses, tighten connections. Check ohm resistance on elements.
<b>Wire burned or melted at element</b>	Loose connections. Water leaking on elements	Tighten connection and replace wire. Isolate leaking water and repair. Replace wire with same type and size.



**DURAWATT® ELECTRIC WATER HEATERS**

# DURAWATT® ELECTRIC WATER HEATERS