

INSTALLATION AND SERVICE MANUAL

power vented gas-fired unit heaters

model PTP



All models approved for use in California by the CEC and in Massachusetts. Unit heater is certified for non-residential applications.

FOR YOUR SAFETY

The use and storage of gasoline or other flammable vapors and liquids in open containers in the vicinity of this appliance is hazardous.

! WARNING

1. Improper installation, adjustment, alteration, service, or maintenance can cause property damage, injury, or death, and could cause exposure to substances which have been determined by various state agencies to cause cancer, birth defects, or other reproductive harm. Read the installation, operating, and maintenance instructions thoroughly before installing or servicing this equipment.
2. Do not locate ANY gas-fired units in areas where chlorinated, halogenated, or acidic vapors are present in the atmosphere. These substances can cause premature heat exchanger failure due to corrosion, which can cause property damage, serious injury, or death.

IMPORTANT

The use of this manual is specifically intended for a qualified installation and service agency. All installation and service of these units must be performed by a qualified installation and service agency.

FOR YOUR SAFETY

WHAT TO DO IF YOU SMELL GAS:

1. Open windows.
2. Do not try to light any appliance.
3. Do not touch any electrical switch; do not use any phone in your building.
4. Extinguish any open flame.
5. Immediately call your gas supplier from a neighbor's phone. Follow the gas supplier's instructions. If you can not reach your gas supplier, call your fire department.

Inspection on Arrival

1. Inspect unit upon arrival. In case of damage, report it immediately to transportation company and your local Modine sales representative.
2. Check rating plate on unit to verify that power supply meets available electric power at the point of installation.
3. Inspect unit upon arrival for conformance with description of product ordered (including specifications where applicable).

Table of Contents

Inspection on Arrival	1
Special Precautions	2
SI (Metric) Conversion Factors	3
Before You Begin	3
Unit Location	4
Combustible Material and Service Clearances	4
Unit Mounting	5
Installation	6
Venting	6
Gas Connections	10
High-Altitude Accessory Kit	11
Electrical Connections	13
Operation	14
Unit Components	15
Performance Data - General	15
Performance Data - Downturn Hoods	16
Dimensions	17
Service/Maintenance/Troubleshooting	18
Model/Serial Number/Replacement Parts	19
Commercial Warranty	Back Cover

SPECIAL PRECAUTIONS

SPECIAL PRECAUTIONS

THE INSTALLATION AND MAINTENANCE INSTRUCTIONS IN THIS MANUAL MUST BE FOLLOWED TO PROVIDE SAFE, EFFICIENT AND TROUBLE-FREE OPERATION. IN ADDITION, PARTICULAR CARE MUST BE EXERCISED REGARDING THE SPECIAL PRECAUTIONS LISTED BELOW. FAILURE TO PROPERLY ADDRESS THESE CRITICAL AREAS COULD RESULT IN PROPERTY DAMAGE OR LOSS, PERSONAL INJURY, OR DEATH. THESE INSTRUCTIONS ARE SUBJECT TO ANY MORE RESTRICTIVE LOCAL OR NATIONAL CODES.

HAZARD INTENSITY LEVELS

1. **DANGER:** Indicates an imminently hazardous situation which, if not avoided, WILL result in death or serious injury.
2. **WARNING:** Indicates a potentially hazardous situation which, if not avoided, COULD result in death or serious injury.
3. **CAUTION:** Indicates a potentially hazardous situation which, if not avoided, MAY result in minor or moderate injury.
4. **IMPORTANT:** Indicates a situation which, if not avoided, MAY result in a potential safety concern.

DANGER

Appliances must not be installed where they may be exposed to a potentially explosive or flammable atmosphere.

WARNING

1. Gas fired heating equipment must be vented - do not operate unvented.
2. A built-in power exhauster is provided - additional external power exhausters are not required or permitted.
3. If an existing heater is being replaced, it may be necessary to resize the venting systems. Improperly sized venting systems can result in vent gas leakage or the formation of condensate. Refer to the National Fuel Gas Code ANSI Z223.1 (NFPA 54) or CSA B149.1 - latest edition. Failure to follow these instructions can result in injury or death.
4. Under no circumstances should two sections of double wall vent pipe be joined together within one horizontal vent system due to the inability to verify complete seal of inner pipes.
5. All field gas piping must be pressure/leak tested prior to operation. Never use an open flame. Use a soap solution or equivalent for testing.
6. Gas pressure to appliance controls must never exceed 14" W.C. (1/2 psi).
7. To reduce the opportunity for condensation, the minimum sea level input to the appliance, as indicated on the serial plate, must not be less than 5% below the rated input, or 5% below the minimum rated input of dual rated units.
8. Disconnect power supply before making wiring connections to prevent electrical shock and equipment damage.
9. All appliances must be wired strictly in accordance with wiring diagram furnished with the appliance. Any wiring different from the wiring diagram could result in a hazard to persons and property.
10. Any original factory wiring that requires replacement must be replaced with wiring material having a temperature rating of at least 105°C.
11. Ensure that the supply voltage to the appliance, as indicated on the serial plate, is not 5% greater than the rated voltage.

WARNING

12. When servicing or repairing this equipment, use only factory-approved service replacement parts. A complete replacements parts list may be obtained by contacting the factory. Refer to the rating plate on the appliance for complete appliance model number, serial number, and company address. Any substitution of parts or controls not approved by the factory will be at the owner's risk.

CAUTION

1. All literature shipped with this unit should be kept for future use for servicing or service diagnostics. Do not discard any literature shipped with this unit.
2. Consult piping, electrical, and venting instructions in this manual before final installation.
3. Do not attach ductwork, air filters, or polytubes to any propeller unit heater.
4. Clearances to combustible materials are critical. Be sure to follow all listed requirements.
5. Heaters are designed for use in heating applications with ambient startup temperatures between -40°F and 90°F, and ambient operating temperatures between 40°F and 90°F.
6. Do not install unit outdoors.
7. In garages or other sections of aircraft hangars such as offices and shops that communicate with areas used for servicing or storage, keep the bottom of the unit at least 7' above the floor unless the unit is properly guarded to provide user protection from moving parts. In parking garages, the unit must be installed in accordance with the standard for parking structures ANSI/NFPA 88A - latest edition, and in repair garages the standard for repair garages NFPA 30A - latest edition (formerly NFPA 88B). In Canada, installation of heaters in airplane hangars must be in accordance with the requirements of the enforcing authority, and in public garages in accordance with the current CSA-B149 codes.
8. In aircraft hangars, keep the bottom of the unit at least 10' from the highest surface of the wings or engine enclosure of the highest aircraft housed in the hangars and in accordance with the requirements of the enforcing authority and/or NFPA 409 - latest edition.
9. Installation of units in high humidity or salt water atmospheres will cause accelerated corrosion, resulting in a reduction of the normal life of the units.
10. Do not install units below 7' measured from the bottom of the unit to the floor in commercial applications (unless unit is properly guarded to provide user protection from moving parts).
11. Be sure no obstructions block air intake and discharge of unit heaters.
12. The minimum distance from combustible material is based on the combustible material surface not exceeding 160°F. Clearance from the top of the unit may be required to be greater than the minimum specified if heat damage, other than fire, may occur to materials above the unit heater at the temperature described.
13. Allow 18" of clearance at rear (or 12" beyond end of motor at rear of unit, whichever is greater) and access side to provide ample air for proper operation of fan.
14. Installation must conform with local building codes or in the absence of local codes, with the National Fuel Gas Code, ANSI Z223.1 (NFPA 54) - latest edition. In Canada installation must be in accordance with CSA-B149.1.

SPECIAL PRECAUTIONS / SI (METRIC) CONVERSION FACTORS

CAUTION

15. Purging of air from gas supply line should be performed as described in the National Fuel Gas Code, ANSI Z223.1 (NFPA 54) - latest edition. In Canada, installation must be in accordance with CSA-B149.1.
16. When leak testing the gas supply piping system, the appliance and its combination gas control must be isolated during any pressure testing in excess of 14" W.C. (1/2 psi).
17. The unit should be isolated from the gas supply piping system by closing its field installed manual shut-off valve. This manual shut-off valve should be located within 6' of the heater.
18. Turn off all gas before installing appliance.
19. Ensure that the supply voltage to the appliance, as indicated on the serial plate, is less than 5% below the rated voltage.
20. Check the gas inlet pressure at the unit upstream of the combination gas control. The inlet pressure should be 6-7" W.C. on natural gas or 12-14" W.C. on propane. If inlet pressure is too high, install an additional pressure regulator upstream of the combination gas control.
21. Service or repair of this equipment must be performed by a qualified service agency.
22. Do not attempt to reuse any mechanical or electronic ignition controller which has been wet. Replace defective controller.

IMPORTANT

1. To prevent premature heat exchanger failure, do not locate ANY gas-fired appliances in areas where corrosive vapors (i.e. chlorinated, halogenated, or acidic) are present in the atmosphere.
2. To prevent premature heat exchanger failure, the input to the appliance as indicated on the serial plate, must not exceed the rated input by more than 5%.
3. Start-up and adjustment procedures must be performed by a qualified service agency.

BEFORE YOU BEGIN

CAUTION

1. All literature shipped with this unit should be kept for future use for servicing or service diagnostics. Leave manual with the owner. Do not discard any literature shipped with this unit.
2. Consult piping, electrical, and venting instructions in this manual before final installation.
3. Do not attach ductwork, air filters, or polytubes to any propeller unit heater.

In the U.S., the installation of these units must comply with the National Fuel Gas Code, ANSI Z223.1 (NFPA 54) - latest edition and other applicable local building codes. In Canada, the installation of these units must comply with local plumbing or waste water codes and other applicable codes and with the current code CSA-B149.1.

1. All installation and service of these units must be performed by a qualified installation and service agency only as defined in ANSI Z223.1 (NFPA 54) - latest edition or in Canada by a licensed gas fitter.
2. This unit is certified with the controls furnished. For replacements parts, please order according to the replacement parts list on serial plate. Always know your model and serial numbers. Modine reserves the right to substitute other authorized controls as replacements.
3. Unit is balanced for correct performance. Do not alter fan or operate motors at speeds below what is shown in this manual.
4. Information on controls is supplied separately.
5. The same burner is used for natural and propane gas.

SI (Metric) Conversion Factors

To Convert	Multiply By	To Obtain
"W.C.	0.249	kPa
°F	(°F-32) x 5/9	°C
BTU	1.06	kJ
Btu/ft ³	37.3	kJ/m ³
Btu/hr	0.000293	kW
CFH (ft ³ /hr)	0.000472	m ³ /min
CFH (ft ³ /hr)	0.00000787	m ³ /s
CFM (ft ³ /min)	0.0283	m ³ /min
CFM (ft ³ /min)	0.000472	m ³ /s
feet	0.305	m
Gal/Hr.	0.00379	m ³ /hr
Gal/Hr.	3.79	l/hr
gallons	3.79	l
Horsepower	746	W
inches	25.4	mm
pound	0.454	kg
psig	6.89	kPa
psig	27.7	"W.C.

UNIT LOCATION

UNIT LOCATION

⚠ DANGER

Appliances must not be installed where they may be exposed to a potentially explosive or flammable atmosphere.

⚠ CAUTION

- Clearances to combustible materials are critical. Be sure to follow all listed requirements.
- Heaters are designed for use in heating applications with ambient startup temperatures between -40°F and 90°F, and ambient operating temperatures between 40°F and 90°F.
- Do not install unit outdoors.
- In garages or other sections of aircraft hangars such as offices and shops that communicate with areas used for servicing or storage, keep the bottom of the unit at least 7' above the floor unless the unit is properly guarded. In parking garages, the unit must be installed in accordance with the standard for parking structures ANSI/NFPA 88A - latest edition, and in repair garages the standard for repair garages NFPA 30A - latest edition (formerly NFPA 88B). In Canada, installation of heaters in airplane hangars must be in accordance with the requirements of the enforcing authority, and in public garages in accordance with the current CSA-B149 codes.
- In aircraft hangars, keep the bottom of the unit at least 10' from the highest surface of the wings or engine enclosure of the highest aircraft housed in the hangars and in accordance with the requirements of the enforcing authority and/or NFPA 409 - latest edition.
- Installation of units in high humidity or salt water atmospheres will cause accelerated corrosion resulting in a reduction of the normal life of the units.

IMPORTANT

To prevent premature heat exchanger failure, do not locate ANY gas-fired appliances in areas where corrosive vapors (i.e. chlorinated, halogenated or acidic) are present in the atmosphere.

Location Recommendations

- When locating the heater, consider general space and heating requirements, availability of gas and electrical supply, and proximity to vent locations.
- When locating units, it is important to consider that the exhaust vent piping must be connected to the outside atmosphere. Maximum equivalent vent lengths are listed in "Section A - General Instruction - All Units" of the Venting instructions.
- Be sure the structural support at the unit location site is adequate to support the unit's weight. Refer to page 17 for unit weights. For proper operation the unit must be installed in a level horizontal position.
- Do not install units in locations where the flue products can be drawn into the adjacent building openings such as windows, fresh air intakes, etc.
- Be sure that the minimum clearances to combustible materials and recommended service clearances are maintained. Units are designed for installation with the minimum clearances as shown in Figure 4.1 and Table 4.1.

Figure 4.1 - Combustible Material and Service Clearances

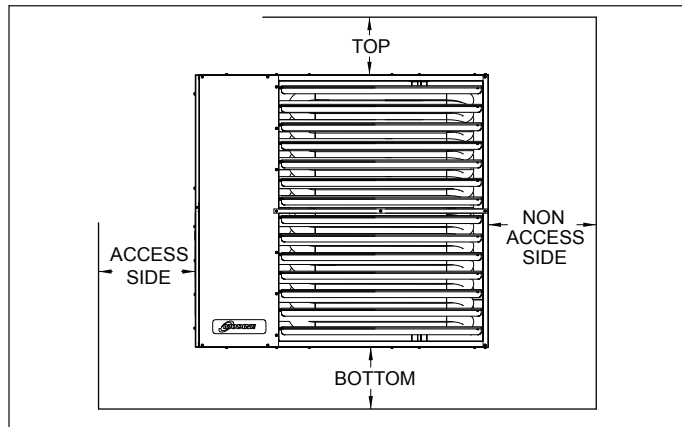

Table 4.1 - Clearances

Unit Side	Clearance To Combustible Materials	Recommended Service Clearance
Top and Bottom	6"	6"
Access Side	6"	18"
Non-Access Side	6"	6"
Rear	18"	18"
Vent Connector	6"	6"

- Do not install units in locations where gas ignition system is exposed to water spray, rain, or dripping water.
- Mounting height (measured from bottom of unit) at which unit heaters are installed is critical. Refer to mounting height and heat throw data on page 15 of this manual. The maximum mounting height for any unit is that height above which the unit will not deliver heated air to the floor.

Combustion Air Requirements

The National Fuel Gas Code defines an "unconfined space" as a space whose volume is greater than 50 cubic feet per 1,000 Btu/Hr input of the installed appliance(s). A confined space is 50 cubic feet or less per 1,000 Btu/Hr input of the installed appliance(s).

Units installed in tightly sealed buildings or confined spaces must be provided with 2 permanent openings - 1 near the top and 1 near the bottom of the confined space. Each opening should have a free area of not less than one square inch per 1,000 Btu/Hr of the total input rating of all units in the confined space, freely communicating with interior areas that have adequate infiltration from the outside.

For further details on supplying combustion air to a confined (tightly sealed) space or unconfined space, see the National Fuel Gas Code ANSI Z223.1 (NFPA 54) or CSA-B149.1 Installation Code - latest edition.

Sound and Vibration Levels

All standard mechanical equipment generates some sound and vibration that may require attenuation. Libraries, private offices and hospital facilities will require more attenuation, and in such cases, an acoustical consultant may be retained to assist in the application. Locating the equipment away from the critical area is desirable within ducting limitations. Generally, a unit should be located within 15' of a primary support beam. Smaller deflections typically result in reduced vibration and noise transmission.

UNIT MOUNTING

CAUTION

1. Do not install units below 7' measured from the bottom of the unit to the floor in commercial applications (unless unit is properly guarded to provide user protection from moving parts).
2. Be sure no obstructions block air intake and discharge of unit heaters.
3. The minimum distance from combustible material is based on the combustible material surface not exceeding 160°F. Clearance from the top of the unit may be required to be greater than the minimum specified if heat damage, other than fire, may occur to materials above the unit heater at the temperature described.
4. Allow 18" clearance at rear (or 12" beyond end of motor at rear of unit, whichever is greater) and access side to provide ample air for proper operation of fan.

1. Be sure the means of suspension is adequate to support the weight of the unit (see page 17 for unit weights).
2. For proper operation, the unit must be installed in a level horizontal position.
3. Clearances to combustibles as specified in Table 4.1 must be strictly maintained.
4. All standard units are shipped fully boxed. Larger units are also supplied with skid supports on the bottom of the box. The larger units may be lifted from the bottom by means of a fork lift or other lifting device only if the shipping support skids are left in place and the forks support the whole depth of the unit. If the unit must be lifted from the bottom for final installation without the carton in place, be sure to properly support the unit over its entire length and width to prevent damage. When lifting units, make sure the load is balanced.
5. Propeller models have 4 mounting holes. The units can be mounted with 3/8"-16 threaded rod as follows:
 - On each piece of threaded rod used, screw a nut a distance of about 1" onto the end of the threaded rods that will be screwed into the unit heater.
 - Place a washer over the end of the threaded rod and screw the threaded rod into the unit heater weld nuts on the top of the heater at least 5 turns, and no more than 10 turns. Tighten the nut first installed onto the threaded rod to prevent the rod from turning.
 - Drill holes into a steel channel or angle iron at the same center-line dimensions as the heater that is being installed. The steel channels or angle iron pieces need to span and be fastened to appropriate structural members.
 - Cut the threaded rods to the preferred length, place them through the holes in the steel channel or angle iron and secure with washers and lock nuts or lock washers and nuts. A double nut arrangement can be used here instead of at the unit heater (a double nut can be used both places but is not required).
 - Do not install standard unit heaters above the maximum mounting height shown in Table 15.1.

NOTE: A pipe hanger adapter kit, shown in Figure 5.1 is available as an accessory. One kit consists of two drilled 3/4" IPS pipe caps and two 3/8"-16 x 1-1/2" capscrews to facilitate threaded pipe suspension. Two kits would be required for PTP units.

Figure 5.1 - Unit Heater Suspension Methods

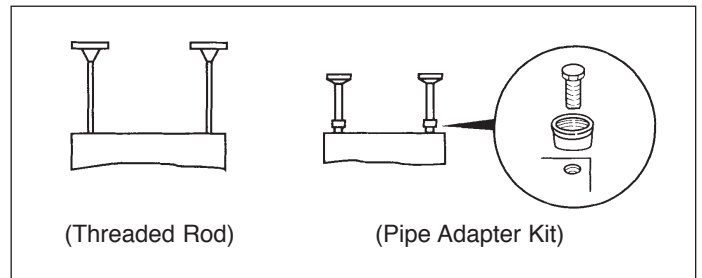

INSTALLATION - VENTING

⚠ WARNING

1. Gas fired heating equipment must be vented - do not operate unvented.
2. A built-in power exhauster is provided - additional external power exhausters are not required or permitted.
3. If an existing heater is being replaced, it may be necessary to resize the venting systems. Improperly sized venting systems can result in vent gas leakage or the formation of condensate. Refer to the National Fuel Gas Code ANSI Z223.1 (NFPA 54) or CSA B149.1 - latest edition. Failure to follow these instructions can result in serious injury or death.
4. Under no circumstances should 2 sections of double wall vent pipe be joined together within 1 horizontal vent system due to the inability to verify complete seal of inner pipes.

⚠ CAUTION

Installation must conform with local building codes or in the absence of local codes, with Part 7, Venting of Equipment, of the National Fuel Gas Code, ANSI Z223.1 (NFPA 54) - latest edition. In Canada installation must be in accordance with CSA B149.1.

Model PTP unit heaters must be vented with the proper passageway as described in these instructions to convey flue gases from the unit or the vent connector to the outside atmosphere.

The venting instructions are organized in sections, based on installation type. The sections are identified as follows:

Instructions	Applicable Installation Instructions by Vent System Type
A	General Instructions for ALL Installations
B	VERTICAL CATEGORY I vent systems ①
C	HORIZONTAL CATEGORY III vent systems ①

① The differences between Vertical and Horizontal vent systems will be identified in "Section A - General Instructions - All Units".

Section A - General Instructions - All Units

- A1. If the unit heater being installed is replacing existing equipment and using the existing vent system from that equipment, inspect the venting system for proper size and horizontal pitch, as required in the National Fuel Gas Code, ANSI Z223.1 (NFPA 54) or CSA B149.1 Installation Code - latest edition and these instructions. Determine that there is no blockage or restriction, leakage, corrosion and other deficiencies, which could cause an unsafe condition.
- A2. The vent pipe should be galvanized steel or other suitable corrosion-resistant material. Follow the National Fuel Gas Code for minimum thickness of vent material. The minimum thickness for connectors varies depending on the pipe diameter. Do not vent unit with PVC or other forms of plastic venting material.
- A3. All heaters come with a factory installed vent adapter for attaching the vent pipe to the heater (see Table 6.1). Attach the vent pipe to the adapter with 3-corrosion resistant screws. (Drill pilot holes through the vent pipe and adapter prior to screwing in place). Vent pipe must not be smaller than the connector size.

- A4. Refer to Table 6.1 for total minimum and maximum vent lengths, making the system as straight as possible. The equivalent length of a 90° elbow is 5 feet for 4 inch diameter and 7 feet for 6 inch diameter.

Table 6.1 - Vent Pipe Diameters, Transitions, and Total Equivalent Vent Pipe Lengths for Horizontal Venting Systems

Model Size	Vent Pipe Diameter	Equivalent Vent Length	
		Minimum	Maximum
150	4"	3'	50'
175-200	4"	3'	70'
250-400	6"	3'	70'

- A5. Horizontal sections of vent pipe are to be installed with a minimum downward slope from the appliance of 1/4 inch per foot and suspended securely from overhead structures at points not greater than 3' apart.
- A6. Fasten individual lengths of vent together with at least 3 corrosion-resistant sheet metal screws.
- A7. Keep single wall vent pipe at least 6" from combustible materials. For double wall vent pipe, follow the vent pipe manufacturer's clearances to combustibles. The minimum distance from combustible materials is based on the combustible material surface not exceeding 160°F. Clearance from the vent pipe (or the top of the unit) may be required to be greater than 6" if heat damage other than fire could result (such as material distortion or discoloration).
- A8. Avoid venting through unheated space when possible. When venting does pass through an unheated space or if the unit is installed in an environment that promotes condensation, insulate runs greater than 5' to minimize condensation. Inspect for leakage prior to insulating and use insulation that is noncombustible with a rating of not less than 400°F. Install a tee fitting at the low point of the vent system and provide a drip leg with a clean out cap as shown in Figure 8.1.

Figure 6.1 - Venting Through Combustible Roof or Wall

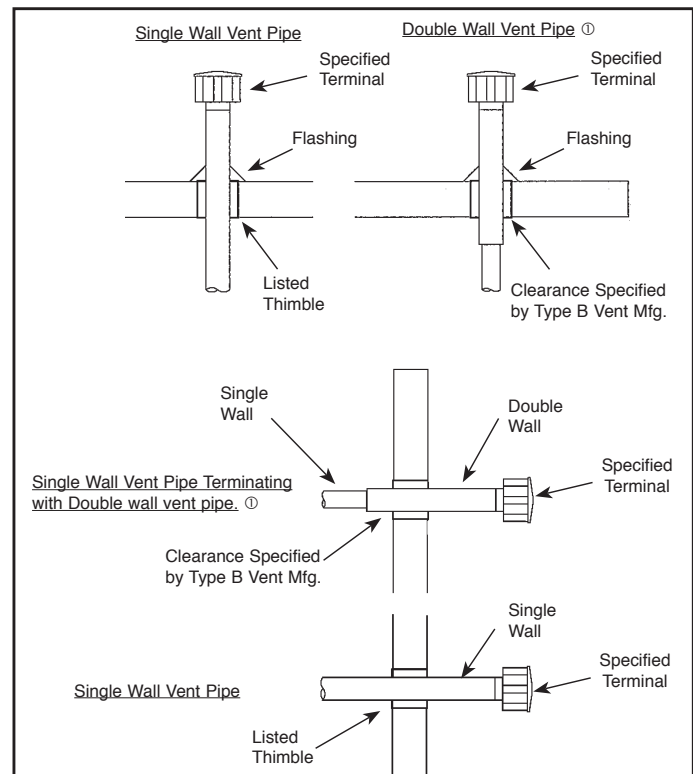

① See Instruction A12 for attaching single wall pipe to double wall pipe

INSTALLATION - VENTING

- A9. When the vent passes through a combustible INTERIOR wall or floor, a metal thimble 4" greater than the vent diameter is necessary. If there is 6' or more of vent pipe in the open space between the appliance and where the vent pipe passes through the wall or floor, the thimble need only be 2" greater than the diameter of the vent pipe. If a thimble is not used, all combustible material must be cut away to provide 6" of clearance. Where authorities have jurisdiction, Type B vent may be used for the last section of vent pipe to maintain clearance to combustibles while passing through wall or floor (see Figure 6.1). Any material used to close the opening must be noncombustible.
- A10. All seams and joints of the single wall pipe must be sealed with metallic tape or silastic suitable for temperatures up to 400°F. Wrap the tape 2 full turns around the vent pipe. One continuous section of double wall vent pipe may be used within the vent system to pass through the wall to a listed vent cap. Refer to instruction A11 in "Section A – General Instructions – All Units" for attaching double wall pipe to single wall pipe.
- A11. The following are General Instructions for Double Wall (Type B) Terminal Pipe Installation:

How to attach a single wall vent terminal to double wall (Type B) vent pipe:

1. Look for the "flow" arrow on the vent pipe.
2. Slide the vent terminal inside the exhaust end of the double wall vent pipe.
3. Drill 3 holes through the pipe and the vent terminal. Using 3/4" long sheet metal screws, attach the cap to the pipe. Do not overtighten.

How to connect a single wall vent system to a double wall (Type B) vent pipe:

1. Slide the single wall pipe inside the inner wall of the double wall pipe.
2. Drill 3 holes through both walls of the single and double wall vent pipes. Using 3/4" sheet metal screws, attach the 2 pieces of pipe. Do not overtighten.
3. The gap between the single and double wall pipe must be sealed but it is not necessary to fill the full volume of the annular area. To seal, run a large bead of 400°F silastic around the gap.

A12. Vent termination clearances must be maintained:

Table 7.1 - Vent Termination Clearances

Structure	Minimum Clearances for Vent Terminal Location
Forced air inlet within 10 feet	3 feet above
Combustion air inlet of another appliance	6 feet all directions
Door, window, gravity air inlet, or any building opening	4 feet horizontal and below 1 foot above
Electric meter, gas meter, gas regulator, and relief equipment ①	4 feet horizontal (U.S.) 6 feet horizontal (Canada)
Gas regulator ①	3 feet horizontal (U.S.) 6 feet horizontal (Canada)
Adjoining building or parapet wall	6 feet all directions
Adjacent public walkways	7 feet all directions
Grade (ground level)	3 feet above

① Do not terminate the vent directly above a gas meter or regulator.

- A13. Do NOT vent this appliance into a masonry chimney.
- A14. Do NOT use dampers or other devices in the vent or combustion air pipes.
- A15. The venting system must be exclusive to a single appliance and no other appliance is allowed to be vented into it.
- A16. Precautions must be taken to prevent degradation of building materials by flue products.
- A17. Single wall vent pipe must not pass through any unoccupied attic, inside wall, concealed space, or floor.
- A18. Uninsulated single wall vent pipe must not be used outdoors for venting appliances in regions where the 99% winter design temperature is below 32°F.
- A19. The vent terminal must be:

Table 7.2 - Vent Terminals

Model Size	Model PN	Other Listed Terminals
150-200	5H0722850001	Gary Steel 1092
250-400	5H0722850002	Gary Steel 1092

A20. In addition to following these General Instructions, specific instructions for Vertical Category I or Horizontal Category III vent systems must also be followed. The following outlines the differences:

Table 7.3 - ANSI Unit Heater Venting Requirements

Category	Description	Venting Requirements
I	Negative vent pressure Non-condensing	Follow standard venting requirements.
II	Negative vent pressure Condensing	Condensate must be drained.
III	Positive vent pressure Non-condensing	Vent must be gas tight.
IV	Positive vent pressure Condensing	Vent must be liquid and gas tight. Condensate must be drained.

Note: Vent connectors serving Category I appliances shall not be connected into any portion of mechanical draft systems operating under positive pressure.

Vertical Category I Vent

- Vertical vent systems terminate vertically (up) (an example is shown in Figure 8.1).
- The horizontal portion of the vent run cannot exceed 75% of the vertical rise (Example: If the vent height is 10', the horizontal portion of the vent system cannot exceed 7.5').
- The vent terminates a minimum of 5' above the vent connector on the unit.
- If the vent system to be installed meets ALL these criteria (an example is shown in Figure 8.1), proceed to "Section B - Vertical Vent System Installation". For all other cases, proceed to the next section for Horizontal Category III Vent System Determination:

Horizontal Category III Vent

- Horizontal vent systems terminate horizontally (sideways) (an example is shown in Figure 9.2).
- A vent system that terminates vertically but has a horizontal run that exceeds 75% of the vertical rise is considered horizontal.
- Horizontal vent configurations are Category III. Additional requirements are covered in "Section C - Horizontal Category III Vent System Installation".

INSTALLATION - VENTING

Section B – Vertical Vent System Installation

- B1. This section applies to vertically vented Category I vent systems and is in addition to “Section A – General Instructions – All Units”.
- B2. Vertical vent systems terminate vertically, and must be sized in accordance with the National Fuel Gas Code, ANSI Z223.1 (NFPA 54) - latest edition.
- B3. The horizontal portion of the vent run cannot exceed 75% of the vertical rise (Example: If the vent height is 10', the horizontal portion of the vent system cannot exceed 7.5').
- B4. It is recommended to install a tee with drip leg and clean out cap as shown in Figure 8.1.
- B5. The vent terminates a minimum of 5' above the vent connector on the unit.
- B6. All vertically vented heaters that are Category I must be connected to a vent complying with a recognized standard, with a material acceptable to the authority having jurisdiction. Venting into a masonry chimney is not permitted. Refer to the National Fuel Gas Code, ANSI Z223.1 (NFPA 54) - latest edition for instructions on common venting.
- B7. Use a listed vent terminal to reduce down drafts and moisture in the vent.
- B8. Double wall vent pipe is recommended, although single wall can be used if the requirements of the National Fuel Gas Code are followed.
- B9. Vertical vents must terminate a minimum horizontal and vertical distance from roof lines and adjacent walls or obstructions. These minimum distances are outlined as follows (based on National Fuel Gas Code requirements for vents with diameters less than 12"):
- For **double wall** vent pipe and **8' or greater** horizontal distance to any vertical wall or similar obstruction, the vent must terminate above the roof in accordance with Figure 8.1 and Table 8.1.
 - For **double wall** vent pipe and **less than 8'** horizontal distance to any vertical wall or similar obstruction, the vent must terminate at least 2' above the highest point where it passes through a roof of a building and at least 2' higher than any portion of a building within a horizontal distance of 10' (see Figure 8.1).

Figure 8.1 - Vertical Category I Vent System

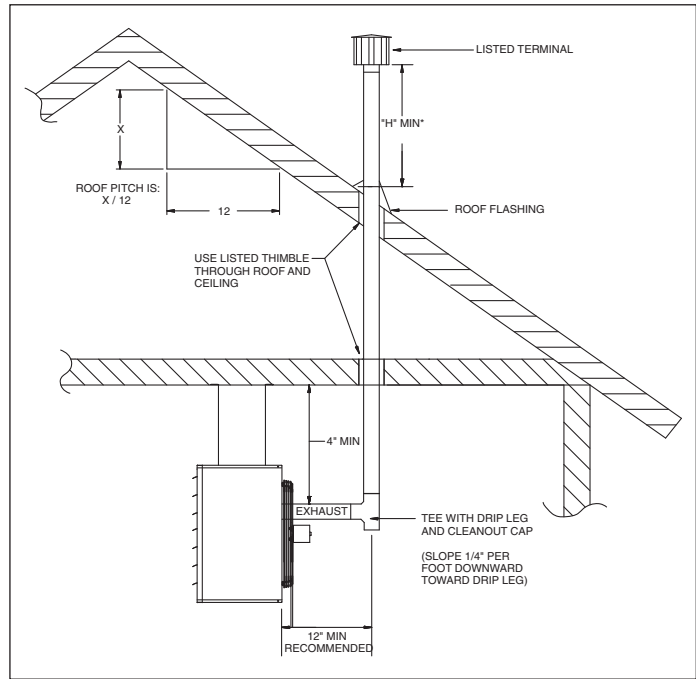

Table 8.1 - Minimum Height from Roof to Lowest Discharge Opening

Rise X (in)	Roof Pitch	Min Height H (ft) ①
0-6	Flat to 6/12	1.00
6-7	6/12 to 7/12	1.25
7-8	7/12 to 8/12	1.50
8-9	8/12 to 9/12	2.00
9-10	9/12 to 10/12	2.50
10-11	10/12 to 11/12	3.25
11-12	11/12 to 12/12	4.00
12-14	12/12 to 14/12	5.00
14-16	14/12 to 16/12	6.00
16-18	16/12 to 18/12	7.00
18-20	18/12 to 20/12	7.50
20-21	20/12 to 21/12	8.00

① Size according to expected snow depth.

- For **single wall** vent pipe and 10' or greater horizontal distance to any portion of a building, the vent must terminate at least 2' above the highest point where it passes through a roof of a building and at least 2' higher than any portion of a building within a horizontal distance of 10'.
- For **single wall** vent pipe and less than 10' horizontal distance to any portion of a building, the vent must terminate at least 2' higher than any portion of that building.

INSTALLATION - VENTING

Section C – Horizontal, Category III Vent System Installation

- C1. This section applies to horizontally vented Category III vent systems and is in addition to “Section A – General Instructions – All Units”.
- C2. Horizontal vent systems terminate horizontally (sideways).
- C3. All seams and joints must be sealed with metallic tape or silastic suitable for temperatures up to 400°F. Wrap the tape 2 full turns around the vent pipe. For single wall vent systems, 1 continuous section of double wall vent pipe may be used within the vent system to pass through the wall to a listed vent cap. Under no circumstances should 2 sections of double wall vent pipe be joined together within 1 vent system due to the inability to verify complete seal of inner pipes. Refer to instruction A10 in “Section A – General Instructions – All Units” for attaching double wall pipe to single wall pipe.
- C4. All horizontal Category III vents must be terminated with a listed vent cap. The cap must terminate a minimum distance of 12" beyond the exterior wall surface as shown in Figure 9.2. The vent must be supported as shown in Figure 9.1. Precautions must be taken to prevent degradation of building materials by flue products.

- C8. For a vent termination located under an eave, the distance of the overhang must not exceed 24". The clearance to combustibles above the exterior vent must be maintained at a minimum of 12". Consult the National Fuel Gas Code for additional requirements for eaves that have ventilation openings.
- C9. Once venting is complete, proceed to the section titled “Installation – Gas Connections”.

Figure 9.1 - Exhaust Vent Construction Through Combustible Walls and Support Bracket

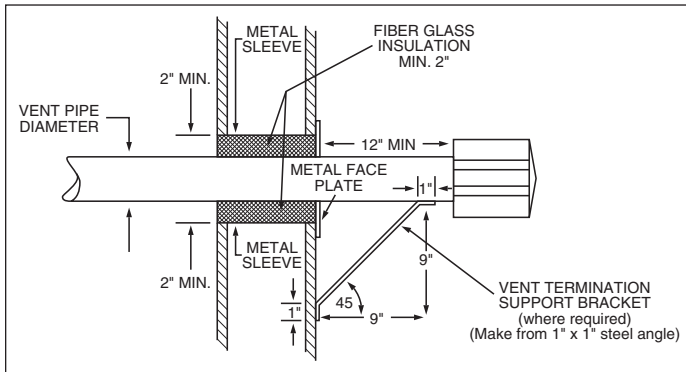

- C5. When condensation may be a problem, the vent system shall not terminate over public walkways or over an area where condensate or vapor could create a nuisance or hazard or could be detrimental to the operation of regulators, relief openings, or other equipment.
- C6. The venting system must be exclusive to a single unit, and no other unit is allowed to be vented into it.
- C7. When vented horizontally, maintain a 1/4" per foot rise away from the heater and place a drip leg with clean out near the unit as shown in Figure 9.2.

Figure 9.2 - Horizontal Venting

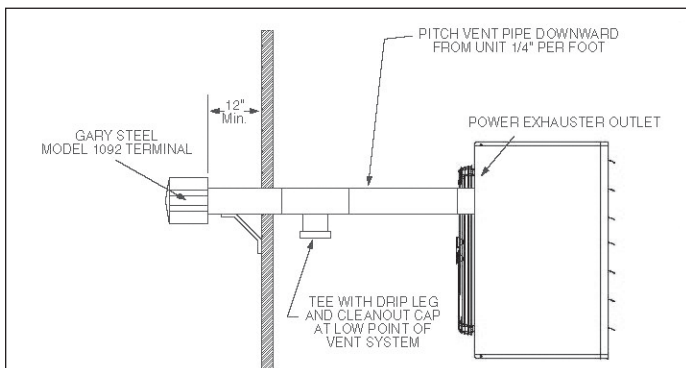

INSTALLATION - GAS CONNECTIONS

GAS CONNECTIONS

⚠ WARNING

1. All field gas piping must be pressure/leak tested prior to operation. Never use an open flame. Use a soap solution or equivalent for testing.
2. Gas pressure to appliance controls must never exceed 14" W.C. (1/2 psi).
3. To reduce the opportunity for condensation, the minimum sea level input to the appliance, as indicated on the serial plate, must not be less than 5% below the rated input, or 5% below the minimum rated input of dual rated units.

⚠ CAUTION

1. Purging of air from gas lines should be performed as described in the National Fuel Gas Code, ANSI Z223.1 (NFPA 54) - latest edition or in Canada CSA-B149 codes.
2. When leak testing the gas supply piping system, the appliance and its combination gas control must be isolated during any pressure testing in excess of 14" W.C. (1/2 psi).
3. The unit should be isolated from the gas supply piping system by closing its field installed manual shut-off valve. This manual shut-off valve should be located within 6' of the heater.
4. Turn off all gas before installing appliance.

IMPORTANT

To prevent premature heat exchanger failure, the input to the appliance, as indicated on the serial plate, must not exceed the rated input by more than 5%.

1. Installation of piping must conform with local building codes, or in the absence of local codes, with the National Fuel Gas Code, ANSI Z223.1 (NFPA 54) - latest Edition. In Canada, installation must be in accordance with CSA-B149.1.
2. Piping to units should conform with local and national requirements for type and volume of gas handled, and pressure drop allowed in the line. Refer to Table 10.1 to determine the cubic feet per hour (CFH) for the type of gas and size of unit to be installed. Using this CFH value and the length of pipe necessary, determine the pipe diameter from Table 10.2. Where several units are served by the same main, the total capacity, CFH and length of main must be considered. Avoid pipe sizes smaller than 1/2". Table 10.2 allows for a 0.3" W.C. pressure drop in the supply pressure from the building main to the unit. The inlet pressure to the unit must be 6-7" W.C. for natural gas and 11-14" W.C. for propane gas. When sizing the inlet gas pipe diameter, make sure that the unit supply pressure can be met after the 0.3" W.C. has been subtracted. If the 0.3" W.C. pressure drop is too high, refer to the Gas Engineer's Handbook for other gas pipe capacities.
3. Install a ground joint union with brass seat and a manual shut-off valve adjacent to the unit for emergency shut-off and easy servicing of controls, including a 1/8" NPT plugged tapping accessible for test gauge connection (see Figure 10.1).
4. Use two wrenches when connecting field piping to units.
5. Provide a sediment trap before each unit in the line where low spots cannot be avoided (see Figure 10.1).
6. When Pressure/Leak testing, pressures above 14" W.C. (1/2 psi), close the field installed shut-off valve, disconnect the appliance and its combination gas control from the gas supply line, and plug the supply line before testing. When testing pressures 14" W.C. (1/2 psi) or below, close the manual shut-off valve on the appliance before testing.

Figure 10.1 - Recommended Sediment Trap/Manual Shut-off Valve Installation - Side or Bottom Gas Connection ①

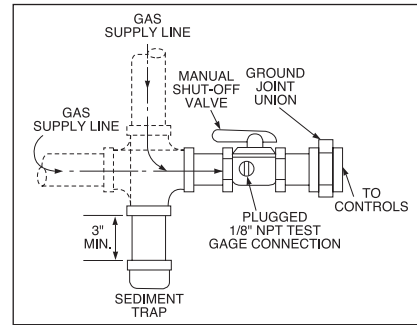

① Manual shut-off valve is in the "OFF" position when handle is perpendicular to pipe.

Table 10.1 - Sea Level Manifold Pressure & Gas Consumption

Model Size	Manifold Pressure ("W.C.):	Natural	Propane	# of Orifices
		3.5	10	
150	CFH	142.9	60.0	6
	Gal/Hr.Propane	n/a	1.6	
	Orifice Drill Size	42	53	
175	CFH	166.7	70.0	7
	Gal/Hr.Propane	n/a	1.9	
	Orifice Drill Size	42	53	
200	CFH	190.5	80.0	7
	Gal/Hr.Propane	n/a	2.2	
	Orifice Drill Size	38	52	
250	CFH	238.1	100.0	9
	Gal/Hr.Propane	n/a	2.7	
	Orifice Drill Size	39	1.55mm	
300	CFH	285.7	120.0	9
	Gal/Hr.Propane	n/a	3.3	
	Orifice Drill Size	35	1.75mm	
350	CFH	333.3	140.0	12
	Gal/Hr.Propane	n/a	3.8	
	Orifice Drill Size	38	52	
400	CFH	381.0	160.0	12
	Gal/Hr.Propane	n/a	4.4	
	Orifice Drill Size	35	1.75mm	

Table 10.2 - Gas Pipe Capacities - Natural Gas ① ②

Pipe Length (ft)	Natural Gas					
	1/2"	3/4"	1"	1-1/4"	1-1/2"	2"
10	132	278	520	1050	1600	3050
20	92	190	350	730	1100	2100
30	73	152	285	590	890	1650
40	63	130	245	500	760	1450
50	56	115	215	440	670	1270
60	50	105	195	400	610	1150
70	46	96	180	370	560	1050
80	43	90	170	350	530	930
100	38	79	150	305	460	870
125	34	72	130	275	410	780
150	31	64	120	250	380	710

① Capacities in Cubic Feet per Hour through Schedule 40 pipe with maximum 0.3" W.C. pressure drop with up to 14" W.C. gas pressure. Specific gravity is 0.60 for Natural gas and 1.50 for Propane gas.

② For Pipe Capacity with Propane Gas, divide Natural gas capacity by 1.6. Example: What is the Propane gas pipe capacity for 60 feet of 1-1/4" pipe? The Natural gas capacity is 400 CFH. Divide by 1.6 to get 250 CFH for Propane gas.

INSTALLATION - HIGH ALTITUDE ACCESSORY KIT

HIGH ALTITUDE ACCESSORY KIT

Modine's gas-fired equipment standard input ratings are certified by ETL. For elevations above 2,000', ANSI Z223.1 requires ratings be reduced 4 percent for each 1,000' above sea level. For units in Canada, CSA requires that ratings be reduced 10 percent at elevations above 2,000'. The high altitude adjustment instructions and pressure switch kits listed in this manual are for use with units that will be installed over 2,000'. These methods and kits comply with both ANSI Z223.1 and CSA requirements.

If a unit is to be installed at higher elevations AND converted from natural gas to propane gas operation, a propane conversion kit must be used in conjunction with the pressure adjustment methods and pressure switch kits listed herein. For the selection and installation instructions for propane conversion kits, please see the latest revision of Modine Manual 75-515.

Selection of the Proper Pressure and Kit

To determine the proper manifold pressure at altitude and if required, the proper combustion air pressure switch kit, the full model number of the heater, the fuel to be used, and the altitude the unit will be installed at must be known. Refer to the unit serial plate or carton label to obtain the necessary information about the unit.

After obtaining this information, refer to the gas pressure and selection charts shown in Tables 11.1 through 11.3. The pressure charts are differentiated by elevation, fuel type, and country the product is being installed in. The selection charts are differentiated by product type, altitude and fuel type. **If converting from natural gas to propane gas and operation at high altitude, both a propane conversion kit and a pressure switch kit must be used (if applicable).** Selection charts include the proper kit suffix, when required.

Table 11.1 - Natural Gas Heating Values at Altitude ① ③ ④

Altitude (ft)	Gas Heating Values at Altitude (BTU/ft ³)	
	USA	Canada
0-2,000	1,050	1,050
2,001-3,000	929	945
3,001-4,000	892	
4,001-4,500	874	
4,501-5,000	856	856
5,001-6,000	822	822
6,001-7,000	789	789
7,001-8,000	757	757
8,001-9,000	727	727
9,001-10,000	698	698

- ① Values shown are for 3.5" W.C. manifold pressure, for other BTU content values (available from local utility) use Equation 12.1 to calculate manifold pressure.
- ② Values shown are for 10.0" W.C. manifold pressure, for other BTU content values (available from local utility) use Equation 12.1 to calculate manifold pressure.
- ③ When installed at altitudes above 2,000', a pressure switch may need to be changed. Refer to Table 11.3 to determine if a switch change is required.
- ④ Gas heating values are derated 4% per 1,000' of elevation in the USA and 10% between 2,000' and 4,500' elevation in Canada in accordance with ANSI Z223.1 and CSA-B149, respectively.

Manifold Pressure Adjustment

The inlet pressure to the unit must be confirmed to be within acceptable limits (6-7" W.C. for natural gas and 11-14" W.C. for propane gas) before opening the shutoff valve or the combination gas valve may be damaged.

Heaters for use with **natural gas** have gas valves factory set at 3.5" W.C. manifold pressure at 7.0" W.C. inlet pressure.

Units for use with **propane gas** are set for 10.0" W.C. manifold pressure at 14.0" W.C. inlet pressure.

Installation above 2,000' elevation requires adjustment of the manifold pressure as described.

Derated BTU Content Gas and Manifold Pressure Calculation

Some utility companies may derate the BTU content (heating value) of the gas provided at altitude to a value other than 1,050 BTU/ft³ for natural gas or 2,500 BTU/ft³ for propane gas to allow certain heating appliances to be used with no manifold pressure adjustments. For this reason it is necessary that the supplying utility be contacted for detailed information about the gas type and BTU content (heating value) before operating any heater. Tables 11.1 and 11.2 show the standard derated heating values (4% per 1,000' of elevation in the USA and 10% between 2,001' and 4,500' elevation in Canada) of natural and propane gases at various altitudes. If the utility is supplying gas with heating values as shown in Tables 11.1 and 11.2, the manifold pressure should be set to 3.5" W.C. for natural gas and 10.0" W.C. for propane gas.

NOTE: Only the high fire gas pressure need be adjusted, low fire gas pressure should remain the same.

Table 11.2 - Propane Gas Heating Values at Altitude ② ③ ④

Altitude (ft)	Gas Heating Values at Altitude (BTU/ft ³)	
	USA	Canada
0-2,000	2,500	2,500
2,001-3,000	2,212	2,250
3,001-4,000	2,123	
4,001-4,500	2,080	
4,501-5,000	2,038	2,038
5,001-6,000	1,957	1,957
6,001-7,000	1,879	1,879
7,001-8,000	1,803	1,803
8,001-9,000	1,731	1,731
9,001-10,000	1,662	1,662

Table 11.3 - High Altitude Kits for PTP ①

Model Size	Details	U.S.A. and Canada				
		0-2,000 ft	2,001-4,500 ft	4,501-5,500 ft	5,501-6,500 ft	6,501-7,500 ft
150-250	Kit Suffix	Not Required	Label Only	Label Only	Label Only	Label Only
	Item Code					
300	Kit Suffix	Not Required	Label Only	Label Only	0008	0008
	Item Code				68412	68412
350	Kit Suffix	Not Required	Label Only	Label Only	Label Only	Label Only
	Item Code					
400	Kit Suffix	Not Required	0009	0009	0009	0009
	Item Code		68413	68413	68413	68413

① For Label Only kits, Modine part number 5H0807146005 is required to be filled out and attached to the unit by the installer. Please contact the local Modine representative at 1.866.828.4328 (HEAT).

INSTALLATION - HIGH ALTITUDE ACCESSORY KIT

If the heating value of the gas being supplied is different than the values shown in Tables 11.1 and 11.2, use the following equation to determine the appropriate manifold pressure for the altitude and gas heating value being supplied.

Equation 12.1 - Manifold Pressure for Derated Gas

$$MP_{ACT} = \left(\frac{BTU_{TBL}}{BTU_{ACT}} \right)^2 \times MP_{SL}$$

WHERE:

MP_{ACT} = **Manifold Pressure (in. W.C.) at Altitude** –
Manifold pressure setting for the heater being installed

BTU_{TBL} = **BTU/ft³ Content of Gas** –
Obtained from Tables 11.1 or 11.2 (whichever is applicable)

BTU_{ACT} = **BTU/ft³ Content of Gas** –
Obtained from the local utility company

MP_{SL} = **Manifold Pressure (in. W.C.), at Sea Level** –
Use 3.5" W.C. for Natural Gas and 10.0" W.C. for propane gas

NOTE: Only the primary manifold pressure should be adjusted on units equipped with two-stage or modulating gas controls. No adjustments to the low fire manifold pressure are necessary on these units.

INSTALLATION - ELECTRICAL CONNECTIONS

ELECTRICAL CONNECTIONS

WARNING

1. Disconnect power supply before making wiring connections to prevent electrical shock and equipment damage.
2. All appliances must be wired strictly in accordance with wiring diagram furnished with the appliance. Any wiring different from the wiring diagram could result in a hazard to persons and property.
3. Any original factory wiring that requires replacement must be replaced with wiring material having a temperature rating of at least 105°C.
4. Ensure that the supply voltage to the appliance, as indicated on the serial plate, is not 5% greater than rated voltage.

CAUTION

Ensure that the supply voltage to the appliance, as indicated on the serial plate, is not 5% less than the rated voltage.

1. Installation of wiring must conform with local building codes, or in the absence of local codes, with the National Electric Code ANSI/NFPA 70 - Latest Edition. Unit must be electrically grounded in conformance to this code. In Canada, wiring must comply with CSA C22.1, Part 1, Electrical Code.

2. Two copies of the unit wiring diagram are provided with each unit. One is located in the side access control compartment and the other is supplied in the literature packet. Refer to this diagram for all wiring connections.
3. Make sure all multi-voltage components (motors, transformers, etc.) are wired in accordance with the power supply voltage.
4. The power supply to the unit must be protected with a fused or circuit breaker switch.
5. The power supply must be within 5 percent of the voltage rating and each phase must be balanced within 2 percent of each other. If not, advise the utility company.
6. External electrical service connections that must be installed include:
 - a. Supply power connection (115, 208, 230, 460, or 575 volts).
 - b. Connection of thermostats, or any other accessory control devices that may be supplied (24 volts).

NOTE: All units with supply voltage 208V and greater must use a field installed step-down transformer, available as a separate accessory. Refer to Table 13.1 for additional information on the required transformer.

7. Refer to Figure 17.1 for the side access control compartment location.
8. All supply power electrical connections are made in the side access control compartment of the unit. The low voltage (thermostat and accessory control devices) can be wired to the terminals in the side access control compartment. Refer to the wiring diagram for the terminal location of all low voltage wiring.

Table 13.1 - Propeller Unit Model PTP Operating Electrical Data ①

Supply Voltage	Power Code		Model PTP Sizes						
			150	175	200	250	300	350	400
115V 1 Phase	01 (115V)	Motor Amps	2.8	2.8	5.4	5.4	7.5	7.5	8.8
		Total Amps	5.0	5.0	7.6	7.6	8.8	8.8	10.1
		Transformer kVA	n/a	n/a	n/a	n/a	n/a	n/a	n/a
208V 1 Phase	01 (115V) with Transformer	Transformer kVA	1.0	1.0	1.0	1.0	1.5	1.5	1.5
		208V Total Amps	2.76	2.76	4.20	4.20	4.87	4.87	5.58
230V 1 Phase	01 (115V) with Transformer	Transformer kVA	0.75	0.75	1.0	1.0	1.5	1.5	0.25 ②
		230V Total Amps	2.50	2.50	3.80	3.80	4.40	4.40	5.05
208V 3 Phase	01 (115V) with Transformer	Transformer kVA	1.0	1.0	1.0	1.0	1.5	1.5	1.5
		208V Total Amps	2.76	2.76	4.20	4.20	4.87	4.87	5.58
230V 3 Phase	01 (115V) with Transformer	Transformer kVA	0.75	0.75	1.0	1.0	1.5	1.5	1.5
		230V Total Amps	2.50	2.50	3.80	3.80	4.40	4.40	5.05
460V 3 Phase	01 (115V) with Transformer	Transformer kVA	0.75	0.75	1.0	1.0	1.5	1.5	1.5
		460V Total Amps	1.25	1.25	1.90	1.90	2.20	2.20	2.53
575V 3 Phase	01 (115V) with Transformer	Transformer kVA	0.75	0.75	1.0	1.0	1.5	1.5	1.5
		575V Total Amps	1.00	1.00	1.52	1.52	1.76	1.76	2.02

① Amp draw data shown is operating amp draw at incoming power. For units that use a field installed accessory step-down transformer as noted, the amp draw shown is the primary side operating amp draw. For sizing of circuit protection for equipment with transformers, please refer to the National Electric Code.

② For PTP units that are used on 230V/1ph, all models are equipped with 115V motors except the PTP400 which is equipped with motors that can operate on 230V. Since the transformer does not need to be sized to include the propeller motor, the rating of the Step Down Transformer Accessory is sized smaller for the power exhaustor and gas control circuit only.

INSTALLATION - OPERATION

OPERATION

Prior to Operation

IMPORTANT

1. To prevent premature heat exchanger failure, the input to the appliance as indicated on the serial plate, must not exceed the rated input by more than 5%.
2. Start-up and adjustment procedures must be performed by a qualified service agency.

Although this unit has been assembled and fire-tested at the factory, the following pre-operational procedures should be performed to assure proper on-site operation:

1. Turn off power to the unit at the disconnect switch. Check that fuses or circuit breakers are in place and sized correctly. Turn all hand gas valves to the "OFF" position.
2. Remove the side control access panel.
3. Check that the supply voltage matches the unit supply voltage listed on the Model Identification plate. Verify that all wiring is secure and properly protected. Trace circuits to insure that the unit has been wired according to the wiring diagram. If installed at altitudes above 2,000' and the high altitude kit includes a combustion air proving switch, replace the switch in the unit with the switch provided in the kit. Take care to ensure that the tubing and electrical connections are securely fastened.
4. Check to insure that the venting system is installed correctly and free from obstructions. Before you start use the following steps to verify that the venting system is adequately sized:
 - a. Seal any unused openings in the venting system.
 - b. Inspect the venting system for proper size and horizontal pitch, as required in the National Fuel Gas Code, ANSI Z223.1 (NFPA 54) or CSA B149.1 Installation Code - latest edition and these instructions. Determine that there is no blockage or restriction, leakage, corrosion, or other deficiencies, which could cause an unsafe condition.
 - c. Insofar as practical, close all building doors and windows and all doors between the space in which the appliance(s) connected to the venting system is (are) located and other spaces of the building. Turn on clothes dryers and any exhaust fans such as range hoods and bathroom exhausts, so they shall operate at maximum speed. Do not operate a summer exhaust fan. Close fireplace dampers.
 - d. Follow the lighting instructions. Place the appliance being inspected in operation. Adjust thermostat so that the appliance will operate continuously.
 - e. After it has been determined that each appliance connected to the venting system properly vents when tested as outlined above, return doors, windows, exhaust fans, fireplace dampers and any other gas-burning appliance to their previous conditions of use.
 - f. If improper venting is observed during any of the above tests, the venting system must be corrected.
5. Check to see that there are no obstructions to the intake and discharge of the unit.
6. Check fan clearance. Fan should not contact casing when spun by hand.
7. Check to make sure that all filters are in place and that they are installed properly according to direction of air flow (if applicable).
8. Perform a visual inspection of the unit to make sure no damage has occurred during installation. Check to ensure all fasteners are in place and the burner openings are properly aligned with the heat exchanger tubes and that the gas orifices are centered in the burner inspirator tube opening.

9. Check that all horizontal deflector blades are open a minimum of 30° as measured from vertical.
10. Turn on power to the unit at the disconnect switch.
11. Check the thermostat, ignition control, gas valve, and supply fan blower motor for electrical operation. If these do not function, recheck the wiring diagram.
12. Check the motor speed (rpm).
13. Check the motor voltage.
14. Check the motor amp draw to make sure it does not exceed the motor nameplate rating.
15. Recheck the gas supply pressure at the field installed manual shut-off valve. The minimum inlet pressure should be 6" W.C. on natural gas and 11" W.C. on propane gas. The maximum inlet pressure for either gas is 14" W.C. If inlet pressure exceeds 14" W.C., a gas pressure regulator must be added upstream of the combination gas valve.
16. Open the field installed manual gas shut-off valve.
17. Place the manual main gas valve on the combination gas valve in the "On" position. Call for heat with the thermostat.
18. Check to make sure that the main gas valve opens. Check the manifold gas pressure (See "Main Gas Adjustment") while the supply fan blower is operating.
19. Check to insure that gas controls sequence properly (see "Control Operating Sequence"). If you are not familiar with the unit's controls (i.e. combination gas control), refer to the control manufacturer's literature supplied with the unit.
20. Once proper operation of the unit has been verified, remove any jumper wires that were required for testing.
21. Replace the side control access panel.
22. If installed at altitudes above 2,000', affix label included with high altitude kit and fill in all fields with a permanent marker.

Main Burner Adjustment

The gas pressure regulator (integral to the combination gas control) is adjusted at the factory for average gas conditions. It is important that gas be supplied to the unit heater in accordance with the input rating on the serial plate. Actual input should be checked and necessary adjustments made after the unit heater is installed. Over-firing, a result of too high an input, reduces the life of the appliance and increases maintenance. Under no circumstances should the input exceed that shown on the serial plate.

Measuring the manifold pressure is done at the outlet pressure tap of the gas valve.

To Adjust the Manifold Pressure

1. Move the field installed manual shut-off valve to the "OFF" position.
2. Remove the 1/8" pipe plug from the outlet pressure tap on the gas valve and attach a water manometer of "U" tube type which is at least 12" high.
3. Move the field installed manual gas shut-off valve to the "ON" position.
4. Create a high-fire call for heat from the thermostat.
5. Refer to Table 10.1 to determine the correct high fire manifold pressure for the gas type of the unit. Pressures at 0-2,000' elevation are 3.5" W.C. for natural gas, 10" W.C. for propane gas, for elevations above 2,000' refer to the instructions in "Gas Connections - High Altitude Accessory Kit" on page 11. Adjust the main gas pressure regulator spring to achieve the proper manifold pressure (for location, see the combination gas control literature supplied with unit).
6. After adjustment, move the field installed manual shut-off valve to the "OFF" position and replace the 1/8" pipe plug.
7. After the plug is in place, move the field installed manual shut-off valve to the "ON" position and recheck pipe plugs for gas leaks with soap solution.

CONTROL OPERATING SEQUENCE / UNIT COMPONENTS

CONTROL OPERATING SEQUENCE

Upon a call for heat from the thermostat, power is supplied to the power exhauster motor. The unit will go through a purge period and then the direct spark igniter will be energized. At the same time, the main valve in the combination control valve will open to allow gas to flow to the burners. If the fan motor has

not already started it will start shortly. If a flame is not sensed within 7 seconds for any reason the main valve will close and there will be a short purge period before ignition is tried again. If the flame is not sensed after four tries there will be at least a one hour wait before ignition is tried again.

Figure 15.1 - Major Gas, Electrical Service, Safety and Other Components

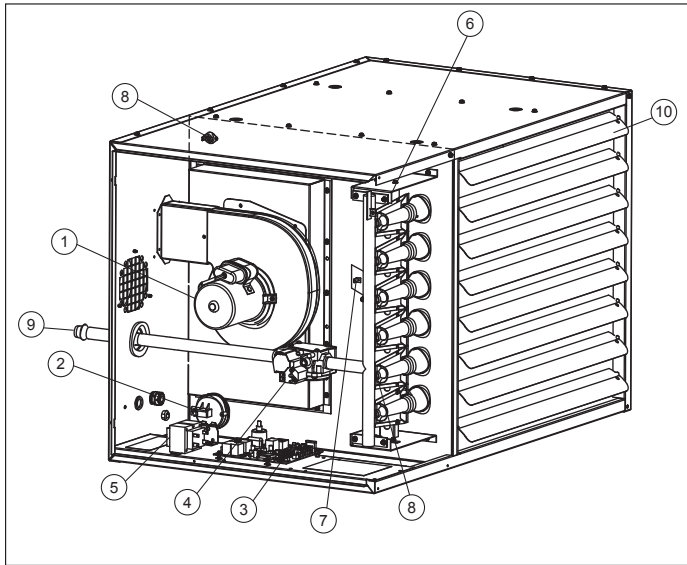

- | | |
|--|--------------------------------------|
| 1. Power Exhauster | 6. Flame Sensor (hidden) |
| 2. Pressure Switch | 7. Auto Reset Limit Control (hidden) |
| 3. Integrated Direct Spark Control Board | 8. Direct Spark Igniter (hidden) |
| 4. Combination Gas Control | 9. Gas Pipe Connection |
| 5. Control Transformer | 10. Horizontal Air Deflector Blades |

Table 15.1 - Gas Controls - All Models

Control System Description	Gas Type	Control Code	Control Voltage	Service Voltage
Single-Stage, Direct Spark Ignition, 100% Shut-off with Continuous Retry Utilizes a single-stage combination gas control with ignition control. Gas is lit with a direct spark igniter on call for heat.	Natural	11	24V	115V
	Propane	21		
Two-Stage, Direct Spark Ignition, 100% Shut-off with Continuous Retry Utilizes a two-stage combination gas control with built-in ignition control. Firing rate is 100% and 50% of full rated input. Gas is lit with a direct spark igniter on call for heat.	Natural	12	24V	115V
	Propane	22		

GENERAL PERFORMANCE DATA - MODEL PTP

Table 15.1 - Propeller Unit Model PTP General Performance Data

	Model PTP Sizes						
	150	175	200	250	300	350	400
Btu/Hr Input ①	150,000	175,000	200,000	250,000	300,000	350,000	400,000
Btu/Hr Output ①	120,000	140,000	160,000	200,000	240,000	280,000	320,000
Entering Airflow (CFM) @ 70°F	2140	2725	2870	3995	4545	5280	5995
Outlet Velocity (FPM)	711	607	643	721	824	748	851
Air Temp. Rise (°F)	53	48	52	47	50	50	51
Max. Mounting Height (Ft.) ②	15	14	15	18	19	18	21
Heat Throw (Ft.) (@ Max Mtg Ht)	51	50	53	62	69	65	74
Motor Type ③	PSC	PSC	PSC	PSC	PSC	PSC	PSC
Motor HP	1/6	1/6	1/3	1/3	1/2	1/2	3/4
Motor RPM	1075	1075	1075	1075	1075	1125	1125

① Ratings shown are for elevations up to 2,000'. For elevations above 2,000', ratings should be reduced at the rate of 4% for each 1,000' above sea level. (In Canada see rating plate.) Reduction of ratings requires use of a high altitude kit.

② Data taken at 55°F air temperature rise. At 65°F ambient and unit fired at full-rated input. Mounting height as measured from bottom of unit, and without deflector hoods. For units equipped with deflector hoods, see page 16.

③ All motors used are produced, rated and tested by reputable manufacturers in accordance with NEMA standards and carry the standard warranty of both the motor manufacturer and Modine. All motors are totally enclosed and all single phase motors have built-in thermal overload protection.

PERFORMANCE DATA - HOODS FOR PROPELLER MODELS

Figure 16.1 - 30°, 60°, and 90° Downward Deflector Hoods

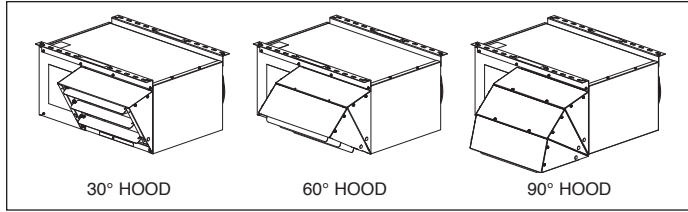

Table 16.2 - Deflector Hood General Performance Data - Model PTP

Model Size	Airflow (cfm)	Temp Rise (°F)	Mounting Height (ft)	Blade Angle (°)	30° Hood			60° Hood			90° Hood
					X (ft)	Y (ft)	Z (ft)	X (ft)	Y (ft)	Z (ft)	S (ft)
150	2139	53	8	60	15	32	44	0	34	47	23
			10	52	13	31	42	0	32	44	21
			12	42	12	29	40	0	29	40	19
			14	30	10	26	36	0	25	34	18
			16	9	7	20	29	0	17	24	17
175	2726	48	8	60	14	32	43	0	33	46	23
			10	51	13	30	42	0	31	43	21
			12	41	12	28	39	0	28	39	19
			14	29	10	25	35	0	24	33	17
			16	8	6	17	26	0	14	21	16
200	2780	52	8	59	14	30	42	0	32	44	22
			10	49	12	29	40	0	30	41	19
			12	39	11	27	37	0	26	36	18
			14	24	9	23	33	0	21	30	16
250	3994	47	8	66	19	41	56	0	43	59	32
			10	60	18	40	54	0	42	57	29
			12	53	17	38	53	0	40	54	26
			14	45	15	36	50	0	37	51	24
			16	37	14	34	47	0	33	46	23
			18	26	12	30	43	0	28	39	21
300	4543	50	8	69	22	45	62	0	48	66	37
			10	63	21	44	61	0	47	64	33
			12	57	19	43	59	0	45	62	30
			14	51	18	42	57	0	43	59	28
			16	43	16	40	55	0	40	55	26
			18	35	15	37	52	0	36	50	25
350	5278	50	20	25	13	33	47	0	31	43	24
			22	9	8	25	37	0	21	30	22
			8	67	20	43	58	0	45	62	34
			10	61	19	42	57	0	44	60	31
			12	55	18	40	55	0	42	58	28
			14	48	16	39	53	0	40	54	26
			16	40	15	37	51	0	36	50	24
			18	30	13	33	47	0	32	44	23
400	5995	51	20	17	10	29	41	0	25	35	22
			21	2	7	23	34	0	18	26	21
			8	70	24	49	66	0	52	71	41
			10	65	22	48	65	0	51	69	37
			12	59	21	47	64	0	49	67	34
			14	54	20	45	62	0	47	64	31
			16	47	18	44	60	0	44	61	29
			18	40	17	41	57	0	41	57	27
			20	32	15	38	54	0	37	51	26
22	21	13	34	48	0	31	43	25			
23	13	11	31	44	0	26	37	24			

Figure 16.2 - 30° and 60° Throw/Floor Coverage

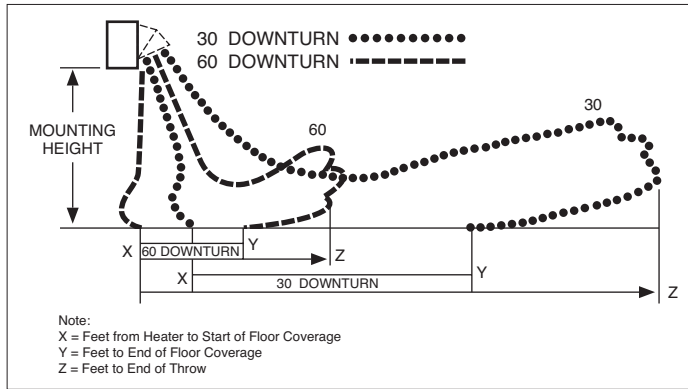
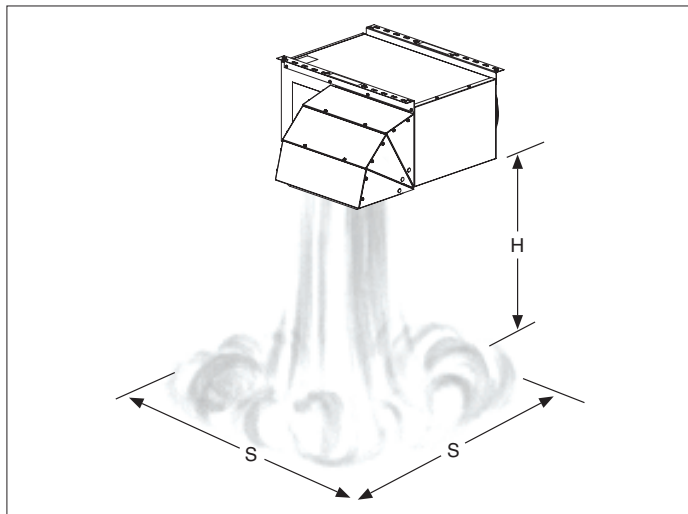

Figure 16.3 - 90° Hood Throw/Floor Coverage



Note: Refer to Figures 16.2 through 16.3.

DIMENSIONAL DATA - MODEL PTP

Propeller Units - Model PTP

Figure 17.1 - Dimensional Drawings

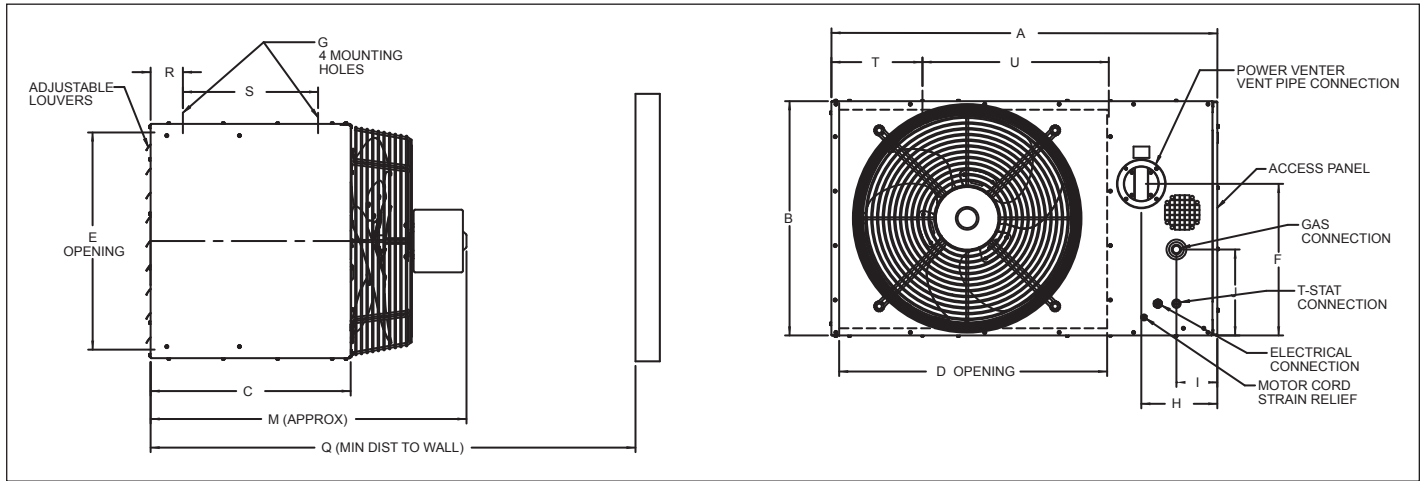

Table 17.1 - Dimensions (inches) - PTP ①

Models	PTP150	PTP175	PTP200	PTP250	PTP300	PTP350	PTP400
A	35.53	42.53	42.53	42.53	42.53	42.53	42.53
B	23.06	25.81	25.81	31.31	31.31	39.56	39.56
C	22.05	22.05	22.05	22.05	22.05	22.05	22.05
D	22.52	29.52	29.52	29.52	29.52	29.52	29.52
E	21.18	23.93	23.93	29.43	29.43	37.68	37.68
F	15.33	16.70	16.70	19.45	19.45	23.58	23.58
G (Mounting Hole) ②	3/8-16	3/8-16	3/8-16	3/8-16	3/8-16	3/8-16	3/8-16
H	8.37	8.37	8.37	8.37	8.37	8.37	8.37
I	4.50	4.50	4.50	4.50	4.50	4.50	4.50
M	31.79	32.83	34.43	33.83	33.83	34.83	34.83
Q ③	43.79	44.83	46.43	45.83	45.83	46.83	46.83
R	3.56	3.56	3.56	3.56	3.56	3.56	3.56
S	14.90	14.90	14.90	14.90	14.90	14.90	14.90
T	10.00	10.00	10.00	10.00	10.00	10.00	10.00
U	13.54	20.53	20.53	20.53	20.53	20.53	20.53
Gas Connection	1/2	1/2	1/2	3/4	3/4	3/4	3/4
Vent Connector Size	4"	4"	4"	6"	6"	6"	6"
Fan Diameter	20.00	22.00	22.00	22.00	22.00	24.00	24.00
Approx. Shipping Weight (lbs.)	165	210	220	265	270	310	320

① Do not use propeller units with duct work.

② Listed is the hole diameter and threads per inch to accept threaded rod.

③ Dimension equals overall plus 12".

SERVICE / MAINTENANCE / TROUBLESHOOTING

WARNING

When servicing or repairing this equipment, use only factory-approved service replacement parts. A complete replacement parts list may be obtained by contacting the factory. Refer to the rating plate on the appliance for complete appliance model number, serial number, and company address. Any substitution of parts or controls not approved by the factory will be at the owner's risk.

CAUTION

1. Service or repair of this equipment must be performed by a qualified service agency.
2. Do not attempt to reuse any mechanical or electrical controllers which have been wet. Replace defective controller.

1. Service air moving components annually.
 - a. Check fan for fit on motor shaft and for damage to blades.
2. Keep unit free from dust, dirt, grease, and foreign matter, paying particular attention to:
 - a. Combustion air inlets.
 - b. Burners and burner orifices. Turn off gas ahead of the combination gas control and shut off electric power to the heater. Remove the access panel, open the union on the gas line, and disconnect the igniter and sensor wires. Remove the screws that attach the burner tray to the header plate and remove the burner tray and manifold assembly from the heater. Carefully clean the burners with a wire brush or other suitable means. Replace any damaged or deteriorating burners or orifices. Install the burner assembly back onto the header, making certain that all screws, pipes and electrical connections are tight.

CAUTION: Be careful when handling the igniter and flame sensor.

3. Inspect the flame sensor and igniter for deterioration and/or cracks.
4. Verify that the burners are touching each other at the carryover points. This will ensure flame carryover from burner to burner.
 - a. Clean exterior of heat exchanger tubes.
 - b. Fan blades.
5. Check wiring for possible loose connections.
6. The gas valves and piping should be checked annually for general cleanliness and tightness. The gas controls should be checked to insure that the unit is operating properly. See control instruction sheets furnished separately with the unit heater.
7. The power exhaust motor bearings have been lubricated for long life and do not require additional lubrication. In dirty atmospheres, it may be desirable to clean the motors and blower housing and blow out the cooling air passages of the motor with compressed air.
8. Perform periodic cleaning of inlet and vent terminal screens.

NOTE: To check most of the Possible Remedies in the troubleshooting guide listed in Table 18.1, refer to the applicable sections of the manual.

General Maintenance

The unit and venting system must be checked once a year by a qualified service technician.

All installation and service of these units must be performed by a qualified installation and service agency.

Before any service, BE SURE TO TURN OFF GAS AT THE MANUAL SHUT-OFF VALVE AHEAD OF THE COMBINATION GAS CONTROL AND TURN OFF ALL ELECTRIC POWER TO THE HEATER.

Table 18.1 - Troubleshooting

TROUBLE	POSSIBLE CAUSE	POSSIBLE REMEDY
Unit does nothing	<ol style="list-style-type: none"> 1. Power supply is off 2. No 24V power to thermostat 3. Thermostat malfunction 4. LED flashes 5. Blown fuse on control board 6. Defective control 	<ol style="list-style-type: none"> 1. Turn on main power 2 a. Check control transformer <ol style="list-style-type: none"> b. If failed transformer - check thermostat wire gage and length 3 a. Verify wire connections to R&W terminals only <ol style="list-style-type: none"> b. Check / replace thermostat 4. Check LED flash code 5. Replace fuse 6. Replace control
LED light off or flashing	<ol style="list-style-type: none"> 1. Blown fuse on control board 2. Multiple causes 	<ol style="list-style-type: none"> 1. Replace fuse 2. Control board LED flash codes vary with control type. A decal is installed in the unit giving a brief description of the applicable codes for your heater. For more detail, see the control board data sheet included with the unit.
Unit starts but does not ignite	<ol style="list-style-type: none"> 1. Main gas is off 2. Air in gas line 3. Main or manifold gas pressure 4. Check gas valve switch 	<ol style="list-style-type: none"> 1. Open manual gas valve 2. Purge gas line 3. Set gas pressures per manual instructions 4. Set gas valve switch to "ON" position
Unit goes through cycle but the burners go out in less than 10 seconds Air circulating fan inoperable	<ol style="list-style-type: none"> 1. Reversed main power polarity 2. Unit not grounded 3. Flame not sensed 1. Loose connections 2. Defective control board 3. Defective fan motor 	<ol style="list-style-type: none"> 1. Black wire - HOT, White wire - NEUTRAL, Green wire - GROUND 2. Ground unit and verify quality of ground connection 3. Check flame sensor probe and connection 1. Check all connections 2. Check control board data sheet and function 3. Check fan motor

MODEL & SERIAL NUMBER / REPLACEMENT PARTS

Model Number Designations (Remove access cover to locate)

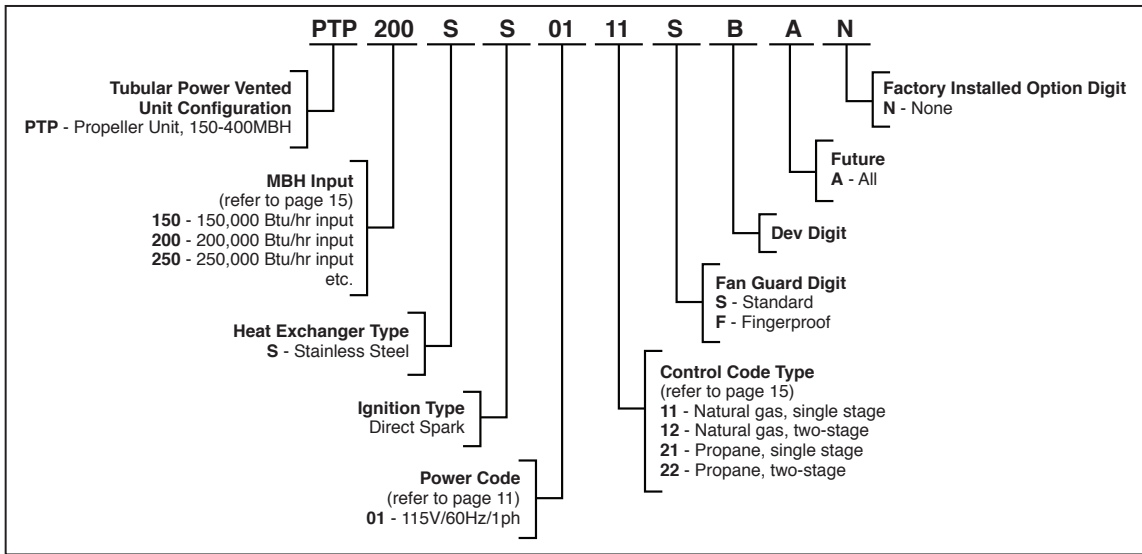

Serial Number Designations (Remove access cover to locate)

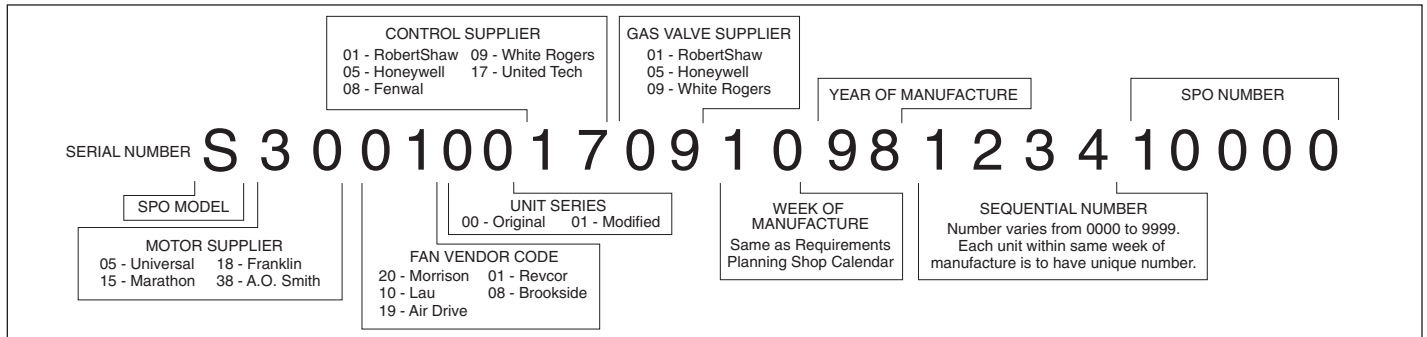

Replacement Parts

When requesting parts please contact your local representative. Please have full model and serial number available. If you require assistance in locating your representative, please call the number located on the back page.

Model Size	Power Exhauster	Limit Control Switch		Pressure Switch	Igniter	Ignition Control (1 Stage)	Combination Gas Valve (1 Stage)		Ignition Control (2 Stage)	Combination Gas Valve (2 Stage)	
		Stalk Mount	Surface Mount				Code 11	Code 21		Code 12	Code 22
PTP150	5H79795	5H75769-2	5H75002-3	5H79441-2	5H079636	5H079749-1700	5H79751	5H79869	5H79804	5H79748	5H79871
PTP175	5H79795	5H75769-5	5H75002-6	5H79441-2	5H079636	5H079749-1700	5H79751	5H79869	5H79804	5H79748	5H79871
PTP200	5H79795	5H75769-5	5H75002-6	5H79441-9	5H079636	5H079749-1700	5H79751	5H79869	5H79804	5H79748	5H79871
PTP250	5H79795	5H75769-1	5H75002-3	5H79441-10	5H079636	5H079749-1700	5H79750	5H79870	5H79804	5H79805	5H79872
PTP300	5H79796	5H75769-1	5H75002-3	5H79441-11	5H079636	5H079749-1700	5H79750	5H79870	5H79804	5H79805	5H79872
PTP350	5H79796	5H75769-1	5H75002-3	5H79441-11	5H079636	5H079749-1700	5H79750	5H79870	5H79804	5H79805	5H79872
PTP400	5H79796	5H75769-1	5H75002-3	5H79441-12	5H079636	5H079749-1700	5H79750	5H79870	5H79804	5H79805	5H79872

COMMERCIAL WARRANTY

Seller warrants its products to be free from defects in material and workmanship, EXCLUSIVE, HOWEVER, of failures attributable to the use of materials substituted under emergency conditions for materials normally employed. This warranty covers replacement of any parts furnished from the factory of Seller, but does not cover labor of any kind and materials not furnished by Seller, or any charges for any such labor or materials, whether such labor, materials or charges thereon are due to replacement of parts, adjustments, repairs, or any other work done. This warranty does not apply to any equipment which shall have been repaired or altered outside the factory of Seller in any way so as, in the judgment of Seller, to affect its stability, nor which has been subjected to misuse, negligence, or operating conditions in excess of those for which such equipment was designed. This warranty does not cover the effects of physical or chemical properties of water or steam or other liquids or gases used in the equipment.

BUYER AGREES THAT SELLER'S WARRANTY OF ITS PRODUCTS TO BE FREE FROM DEFECT IN MATERIAL AND WORKMANSHIP, AS LIMITED HEREIN, SHALL BE IN LIEU OF AND EXCLUSIVE OF ALL OTHER WARRANTIES, EITHER EXPRESS OR IMPLIED, WHETHER ARISING FROM LAW, COURSE OF DEALING, USAGE OF TRADE, OR OTHERWISE, THERE ARE NO OTHER WARRANTIES, INCLUDING WARRANTY OF MERCHANTABILITY OR FITNESS FOR PURPOSE, WHICH EXTEND BEYOND THE PRODUCT DESCRIPTION CONFIRMED BY BUYER AND SELLER AS OF THE DATE OF FINAL AGREEMENT.

This warranty is void if the input to the product exceeds the rated input as indicated on the product serial plate by more than 5% on gas-fired and oil-fired units, or if the product in the judgment of SELLER has been installed in a corrosive atmosphere, or subjected to corrosive fluids or gases, been subjected to misuse, negligence, accident, excessive thermal shock, excessive humidity, physical damage, impact, abrasion, unauthorized alterations, or operation contrary to SELLER'S printed instructions, or if the serial number has been altered, defaced or removed.

BUYER AGREES THAT IN NO EVENT WILL SELLER BE LIABLE FOR COSTS OF PROCESSING, LOST PROFITS, INJURY TO GOODWILL, OR ANY OTHER CONSEQUENTIAL OR INCIDENTAL DAMAGES OF ANY KIND RESULTING FROM THE ORDER OR USE OF ITS PRODUCT, WHETHER ARISING FROM BREACH OF WARRANTY, NONCONFORMITY TO ORDERED SPECIFICATIONS, DELAY IN DELIVERY, OR ANY LOSS SUSTAINED BY THE BUYER.

BUYER'S REMEDY FOR BREACH OF WARRANTY, EXCLUSIVE OF ALL OTHER REMEDIES PROVIDED BY LAW, IS LIMITED TO REPAIR OR REPLACEMENT AT THE FACTORY OF SELLER, ANY COMPONENT WHICH SHALL, WITHIN THE APPLICABLE WARRANTY PERIOD DEFINED HEREIN AND UPON PRIOR WRITTEN APPROVAL, BE RETURNED TO SELLER WITH TRANSPORTATION CHARGES PREPAID AND WHICH THE EXAMINATION OF SELLER SHALL DISCLOSE TO HAVE BEEN DEFECTIVE; EXCEPT THAT WHEN THE PRODUCT IS TO BE USED BY BUYER AS A COMPONENT PART OF EQUIPMENT MANUFACTURED BY BUYER, BUYER'S REMEDY FOR BREACH, AS LIMITED HEREIN, SHALL BE LIMITED TO ONE YEAR FROM DATE OF SHIPMENT FROM SELLER. FOR GAS-FIRED PRODUCTS INSTALLED IN HIGH HUMIDITY APPLICATIONS AND UTILIZING STAINLESS STEEL HEAT EXCHANGERS, BUYER'S REMEDY FOR BREACH, AS LIMITED HEREIN, SHALL BE LIMITED TO TEN YEARS FROM DATE OF SHIPMENT FROM SELLER.

These warranties are issued only to the original owner-user and cannot be transferred or assigned. No provision is made in these warranties for any labor allowance or field labor participation. Seller will not honor any expenses incurred in its behalf with regard to repairs to any of Seller's products. No credit shall be issued for any defective part returned without proper written authorization (including, but not limited to, model number, serial number, date of failure, etc.) and freight prepaid.

OPTIONAL SUPPLEMENTAL WARRANTY

Provided a supplemental warranty has been purchased, Seller extends the warranty herein for an additional four (4) years on certain compressors. Provided a supplemental warranty has been purchased, Seller extends the warranty herein for an additional four (4) years or nine (9) years on certain heat exchangers.

EXCLUSION OF CONSUMABLES & CONDITIONS BEYOND SELLER'S CONTROL

This warranty shall not be applicable to any of the following items: refrigerant gas, belts, filters, fuses and other items consumed or worn out by normal wear and tear or conditions beyond Seller's control, including (without limitation as to generality) polluted or contaminated or foreign matter contained in the air or water utilized for heat exchanger (condenser) cooling or if the failure of the part is caused by improper air or water supply, or improper or incorrect sizing of power supply.

Component Applicable Models	"APPLICABLE WARRANTY PERIOD"
Heat Exchangers Gas-Fired Units	TEN YEARS FROM DATE OF FIRST BENEFICIAL USE BY BUYER OR ANY OTHER USER, WITHIN TEN YEARS FROM DATE OF RESALE BY BUYER OR ANY OTHER USER, WITHIN TEN YEARS FROM DATE OF RESALE BY BUYER IN ANY UNCHANGED CONDITION, OR WITHIN ONE HUNDRED TWENTY-SIX MONTHS FROM DATE OF SHIPMENT FROM SELLER, WHICHEVER OCCURS FIRST
Heat Exchangers Low Intensity Infrared Units Compressors Condensing Units for Cassettes	FIVE YEARS FROM DATE OF FIRST BENEFICIAL USE BY BUYER OR ANY OTHER USER, WITHIN FIVE YEARS FROM DATE OF RESALE BY BUYER OR ANY OTHER USER, WITHIN FIVE YEARS FROM DATE OF RESALE BY BUYER IN ANY UNCHANGED CONDITION, OR WITHIN SIXTY-SIX MONTHS FROM DATE OF SHIPMENT FROM SELLER, WHICHEVER OCCURS FIRST
Burners Low Intensity Infrared Units Other Components excluding Heat Exchangers, Coils, Condensers, Burners, Sheet Metal	TWO YEARS FROM DATE OF FIRST BENEFICIAL USE BY BUYER OR ANY OTHER USER, WITHIN TWO YEARS FROM DATE OF RESALE BY BUYER IN ANY UNCHANGED CONDITION, OR WITHIN THIRTY MONTHS FROM DATE OF SHIPMENT FROM SELLER, WHICHEVER OCCURS FIRST
Heat Exchangers/Coils Indoor and Outdoor Duct Furnaces and System Units, Steam/Hot Water Units, Oil-Fired Units, Electric Units, Cassettes, Vertical Unit Ventilators, Geothermal Units Compressors Vertical Unit Ventilators, Geothermal Units Burners High Intensity Infrared Units Sheet Metal Parts All Products	ONE YEAR FROM DATE OF FIRST BENEFICIAL USE BY BUYER OR ANY OTHER USER, WITHIN ONE YEAR FROM DATE OF RESALE BY BUYER IN ANY UNCHANGED CONDITION, OR WITHIN EIGHTEEN MONTHS FROM DATE OF SHIPMENT FROM SELLER, WHICHEVER OCCURS FIRST

As Modine Manufacturing Company has a continuous product improvement program, it reserves the right to change design and specifications without notice.



Commercial Products Group
 Modine Manufacturing Company
 1500 DeKoven Avenue
 Racine, WI 53403
 Phone: 1.800.828.4328 (HEAT)
 www.modinehvac.com