

# CONDENSING AC UNIT

SINGLE / THREE PHASE AIR CONDITIONERS  
INSTALLATION & SERVICE REFERENCE

© 2010-2011 Goodman Manufacturing Company, L.P.  
5151 San Felipe, Suite 500, Houston, TX 77056  
www.goodmanmfg.com -or- www.amana-hac.com  
P/N: IO-402E Date: December 2011

## NOTICE

THIS UNIT IS SHIPPED WITH A NITROGEN/HELIUM HOLDING CHARGE ONLY. UNIT MUST BE EVACUATED AND CHARGED PER INSTALLATION INSTRUCTIONS WITH REFRIGERANT LISTED ON SERIAL RATING PLATE.

## NOTICE

UNITS SHIPPED WITH A HOLDING CHARGE ARE INTENDED FOR COMPONENT REPLACEMENT ONLY ON EXISTING SYSTEMS, AND NOT INTENDED FOR USE IN NEW SYSTEMS OR NEWLY CONSTRUCTED HOMES.

## NOTICE

UNITS MUST ONLY BE USED AS REPLACEMENT COMPONENTS FOR PRE-2010 INSTALLED SYSTEMS.

Models	Nominal Charge <sup>‡</sup> (oz.)
GSC13018	75
GSC13024	77
GSC13030	66
GSC13036	77
GSC13042	95
GSC13048	89
GSC13060	131

<sup>‡</sup> Approximate charge shown for 15' of 3/8" liquid line. System charge must be adjusted per final charge adjustment (Page 7.)

Outdoor Dry Bulb Temperature, °F	SYSTEM SUPERHEAT									
	Indoor Wet Bulb Temperature, °F									
	55	57	59	61	63	65	67	69	71	
60	10	13	17	20	23	26	29	30	31	
65	8	11	14	16	19	22	26	27	29	
70	5	8	10	13	15	19	23	24	25	
75	----	----	6	9	11	15	20	21	23	
80	----	----	----	----	7	12	17	18	20	
85	----	----	----	----	----	8	13	15	16	
90	----	----	----	----	----	5	10	11	13	
95	----	----	----	----	----	----	5	8	10	
100	----	----	----	----	----	----	----	5	8	
105	----	----	----	----	----	----	----	----	5	
110	----	----	----	----	----	----	----	----	----	
115	----	----	----	----	----	----	----	----	----	

## Fixed Orifice



## CAUTION

To prevent personal injury, carefully connect and disconnect manifold gauge hoses. Escaping liquid refrigerant can cause burns. Do not vent refrigerant into the atmosphere. Recover all refrigerant during system repair and before final unit disposal.

1. Purge gauge lines. Connect service gauge manifold to base-valve service ports. Run system at least 10 minutes to allow pressure to stabilize.
  2. Temporarily install thermometer on suction (large) line near suction line service valve with adequate contact and insulate for best possible reading.
  3. Refer to the superheat table provided for proper system superheat. Add charge to lower superheat or recover charge to raise superheat.
  4. Disconnect manifold set, installation is complete.
- Superheat Formula = Suct. Line Temp. - Sat. Suct. Temp.

## Important Safety Instructions

The following symbols and labels are used throughout this manual to indicate immediate or potential safety hazards. It is the owner's and installer's responsibility to read and comply with all safety information and instructions accompanying these symbols. Failure to heed safety information increases the risk of personal injury, property damage, and/or product damage.



## WARNING

**HIGH VOLTAGE!**  
Disconnect ALL power before servicing.  
Multiple power sources may be present.  
Failure to do so may cause property damage, personal injury or death.



## WARNING

**ONLY individuals meeting the requirements of an "Entry Level Technician", at a minimum, as specified by the Air Conditioning, Heating and Refrigeration Institute (AHRI) may use this information. Attempting to install or repair this unit without such background may result in product damage, personal injury, or death.**

### Important Note to the Owner regarding Product Warranty

Your warranty certificate is supplied as a separate document with the unit installed by your contractor. Read the limited warranty certificate carefully to determine what is and is not covered and keep the warranty certificate in a safe place. If you are unable to locate the warranty certificate please contact your installing contractor or contact customer service (877-254-4729) to obtain a copy.

### Shipping Inspection

Always keep the unit upright; laying the unit on its side or top may cause equipment damage. Shipping damage, and subsequent investigation is the responsibility of the carrier. Verify the model number, specifications, electrical characteristics, and accessories are correct prior to installation. The distributor or manufacturer will not accept claims from dealers for transportation damage or installation of incorrectly shipped units.

### Codes & Regulations

This product is designed and manufactured to comply with national codes. Installation in accordance with such codes and/or prevailing local codes/regulations is the responsibility of the installer. The manufacturer assumes no responsibility for equipment installed in violation of any codes or regulations.

**The United States Environmental Protection Agency (EPA) has issued various regulations regarding the introduction and disposal of refrigerants. Failure to follow these regulations may harm the environment and can lead to the imposition of substantial fines.** Should you have any questions please contact the local office of the EPA.

If replacing a condensing unit or air handler, the system must be manufacturer approved and Air Conditioning, Heating and Refrigeration Institute (AHRI) matched. **NOTE:** Installation of unmatched systems is strongly discouraged.

Operating the unit in a structure that is not complete (either as part of new construction or renovation) will void the warranty.

### Installation Clearances

Special consideration must be given to location of the condensing unit(s) in regard to structures, obstructions, other units, and any/all other factors that may interfere with air circulation. Where possible, the top of the unit should be completely unobstructed; however, if vertical conditions require placement beneath an obstruction **there should be a minimum of 60 inches between the top of the unit and the obstruction(s).** The specified dimensions meet requirements for air circulation only. Consult all appropriate regulatory codes prior to determining final clearances.

Another important consideration in selecting a location for the unit(s) is the angle to obstructions. Either side adjacent the valves can be placed toward the structure provided the side away from the structure maintains minimum service clearance. Corner installations are strongly discouraged.

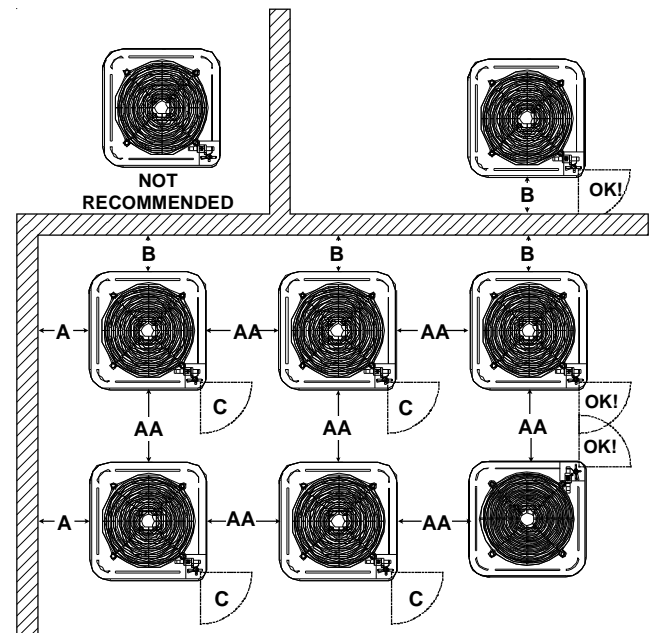

Minimum Airflow Clearance				
Model Type	A	B	C	AA
Residential	10"	10"	18"	20"
Light Commercial	12"	12"	18"	24"

This unit can be located at ground floor level or on flat roofs. At ground floor level, the unit must be on a solid, level foundation that will not shift or settle. To reduce the possibility of sound transmission, the foundation slab should not be in contact with or be an integral part of the building foundation. Ensure the foundation is sufficient to support the unit. A concrete slab raised above ground level provides a suitable base.

### Rooftop Installations

If it is necessary to install this unit on a roof structure, ensure the roof structure can support the weight and that proper consideration is given to the weather-tight integrity of the roof. Since the unit can vibrate during operation, sound vibration transmission should be considered when installing the unit. Vibration absorbing pads or springs can be installed between the condensing unit legs or frame and the roof mounting assembly to reduce noise vibration.

### Safe Refrigerant Handling

While these items will not cover every conceivable situation, they should serve as a useful guide.

## WARNING

**To avoid possible injury, explosion or death, practice safe handling of refrigerants.**

## ⚠ WARNING

Refrigerants are heavier than air. They can "push out" the oxygen in your lungs or in any enclosed space. To avoid possible difficulty in breathing or death:

- Never purge refrigerant into an enclosed room or space. By law, all refrigerants must be reclaimed.
- If an indoor leak is suspected, thoroughly ventilate the area before beginning work.
- Liquid refrigerant can be very cold. To avoid possible frostbite or blindness, avoid contact and wear gloves and goggles. If liquid refrigerant does contact your skin or eyes, seek medical help immediately.
- Always follow EPA regulations. Never burn refrigerant, as poisonous gas will be produced.

## ⚠ WARNING

To avoid possible explosion:

- Never apply flame or steam to a refrigerant cylinder. If you must heat a cylinder for faster charging, partially immerse it in warm water.
- Never fill a cylinder more than 80% full of liquid refrigerant.
- Never add anything other than R-22 to an R-22 cylinder. The service equipment used must be listed or certified for the type of refrigerant used.
- Store cylinders in a cool, dry place. Never use a cylinder as a platform or a roller.

## ⚠ WARNING

To avoid possible explosion, use only returnable (not disposable) service cylinders when removing refrigerant from a system.

- Ensure the cylinder is free of damage which could lead to a leak or explosion.
- Ensure the hydrostatic test date does not exceed 5 years.
- Ensure the pressure rating meets or exceeds 400 lbs.

When in doubt, do not use cylinder.

## Refrigerant Lines

### ⚠ CAUTION

The compressor mineral oil for R-22 units is susceptible to moisture absorption and could cause compressor failure. Do not leave system open to atmosphere any longer than necessary for installation.

Use only refrigerant grade (dehydrated and sealed) copper tubing to connect the condensing unit with the indoor evaporator. After cutting the tubing, install plugs to keep refrigerant tubing clean and dry prior to and during installation. Tubing should always be cut square keeping ends round and free from burrs. Clean the tubing to prevent contamination.

Do NOT let refrigerant lines come in direct contact with plumbing, ductwork, floor joists, wall studs, floors, and walls. When running refrigerant lines through a foundation or wall, openings should allow for sound and vibration absorbing material to be placed or installed between tubing and foundation. Any gap between foundation or wall and refrigerant lines should be filled with a pliable silicon-based caulk, RTV or a vibration damping material. Avoid suspending refrigerant tubing from joists and studs with rigid wire or straps that would come in contact with the tubing. Use an insulated or suspension type hanger. Keep both lines separate and always insulate the suction line.

These sizes are recommended for line lengths of 79 feet or less. For other line sizing option or runs of more than fifty feet, refer to Remote Cooling Service Manual, or TP-106 Long Line Set Application R-22, or contact your distributor for assistance.

RECOMMENDED INTERCONNECTING TUBING (Ft)						
Cond Unit Tons	0-24		25-49		50-79*	
	Line Diameter (In. OD)					
	Suct	Liq	Suct	Liq	Suct	Liq
1 1/2	5/8	1/4	3/4	3/8	3/4	3/8
2	5/8	1/4	3/4	3/8	3/4	3/8
2 1/2	5/8	1/4	3/4	3/8	7/8	3/8
3	3/4	3/8	7/8	3/8	1 1/8	3/8
3 1/2	7/8	3/8	1 1/8	3/8	1 1/8	3/8
4	7/8	3/8	1 1/8	3/8	1 1/8	3/8
5	7/8	3/8	1 1/8	3/8	1 1/8	3/8

\* Lines greater than 79 feet in length or vertical elevation changes more than 50 feet refer to the Remote Cooling Service Manual or contact your distributor for assistance.

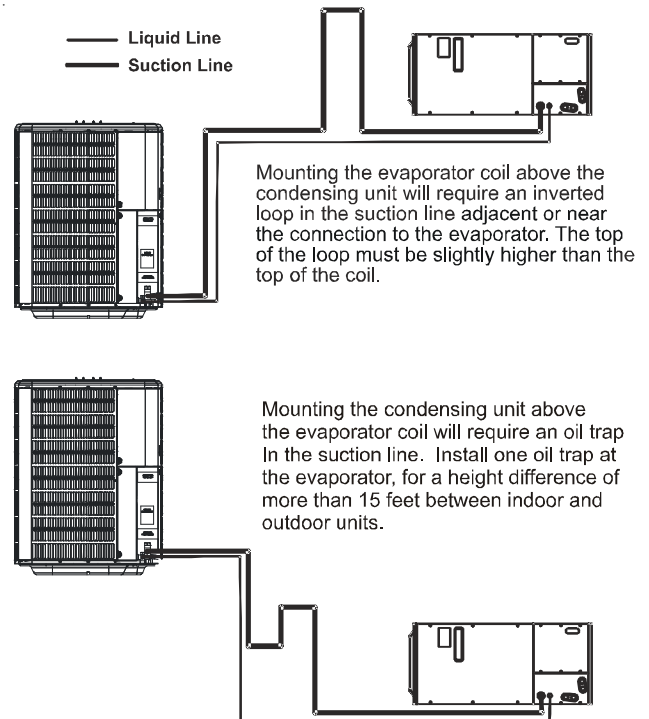

Insulation is necessary to prevent condensation from forming and dropping from the suction line. Armflex (or satisfactory equivalent) with 3/8" min. wall thickness is recommended. In severe conditions (hot, high humidity areas) 1/2" insulation may be required. Insulation must be installed in a manner which protects tubing from damage and contamination.

Where possible, drain as much residual compressor oil from existing systems, lines, and traps; pay close attention to low areas where oil may collect. **NOTE:** If changing refrigerant types, ensure the indoor coil and metering device is compatible with the type of refrigerant being used; otherwise, the indoor coil must be replaced.

### Burying Refrigerant Lines

If burying refrigerant lines can not be avoided, use the following checklist.

1. Insulate liquid and suction lines separately.
2. Enclose all underground portions of the refrigerant lines in waterproof material (conduit or pipe) sealing the ends where tubing enters/exits the enclosure.
3. If the lines must pass under or through a concrete slab, ensure lines are adequately protected and sealed.

### Refrigerant Line Connections

#### NOTICE

**THIS UNIT IS SHIPPED WITH A NITROGEN/HELIUM HOLDING CHARGE ONLY. UNIT MUST BE EVACUATED AND CHARGED PER INSTALLATION INSTRUCTIONS WITH REFRIGERANT LISTED ON SERIAL RATING PLATE.**

#### NOTICE

**UNITS SHIPPED WITH A HOLDING CHARGE ARE INTENDED FOR COMPONENT REPLACEMENT ONLY ON EXISTING SYSTEMS, AND NOT INTENDED FOR USE IN NEW SYSTEMS OR NEWLY CONSTRUCTED HOMES.**

#### NOTICE

**UNITS MUST ONLY BE USED AS REPLACEMENT COMPONENTS FOR PRE-2010 INSTALLED SYSTEMS.**

**NOTE:** Holding charge must be removed before brazing. Open service valves slowly to remove holding charge. Close valves before brazing to prevent contaminants from entering system.

### IMPORTANT

To avoid overheating the service valve, TXV valve, or filter drier while brazing, wrap the component with a wet rag, or use a thermal heat trap compound. Be sure to follow the manufacturer's instruction when using the heat trap compound. Note: Remove Schrader valves from service valves before brazing tubes to the valves. Use a brazing alloy of 2% minimum silver content. Do not use flux.

Torch heat required to braze tubes of various sizes is proportional to the size of the tube. Tubes of smaller size require less heat to bring the tube to brazing temperature before adding brazing alloy. Applying too much heat to any tube can melt the tube. Service personnel must use the appropriate heat level for the size of the tube being brazed. Note: The use of a heat shield when brazing is recommended to avoid burning the serial plate or the finish on the unit.

1. The ends of the refrigerant lines must be cut square, deburred, cleaned, and be round and free from nicks or dents. Any other condition increases the chance of a refrigerant leak.
2. "Sweep" the refrigerant line with nitrogen or inert gas during brazing to prevent the formation of copper-oxide inside the refrigerant lines. This may cause a blockage or failure of the metering device.
3. After brazing, quench the joints with water or a wet cloth to prevent overheating of the service valve.
4. Ensure the filter drier paint finish is intact after brazing. If the paint of the steel filter drier has been burned or chipped, repaint or treat with a rust preventative. This is especially important on suction line filter driers which are continually wet when the unit is operating.

**NOTE:** Be careful not to kink or dent refrigerant lines. Kinked or dented lines will cause poor performance or compressor damage.

Do NOT make final refrigerant line connection until plugs are removed from refrigerant tubing.

**NOTE:** Before brazing, verify indoor piston size by checking the piston kit chart packaged with indoor unit.

### Leak Testing (Nitrogen or Nitrogen-Traced)

#### WARNING

**To avoid the risk of fire or explosion, never use oxygen, high pressure air or flammable gases for leak testing of a refrigeration system.**

#### WARNING

**To avoid possible explosion, the line from the nitrogen cylinder must include a pressure regulator and a pressure relief valve. The pressure relief valve must be set to open at no more than 150 psig.**



Pressure test the system using dry nitrogen and soapy water to locate leaks. If you wish to use a leak detector, charge the system to 10 psi using the appropriate refrigerant then use nitrogen to finish charging the system to working pressure then apply the detector to suspect areas. If leaks are found, repair them. After repair, repeat the pressure test. If no leaks exist, proceed to system evacuation.

### System Evacuation

Condensing unit liquid and suction valves are closed. The unit is shipped with the valve stems closed and caps installed.

**WARNING**  
**REFRIGERANT UNDER PRESSURE!**  
 Failure to follow proper procedures may cause property damage, personal injury or death.

**NOTE:** Scroll compressors should never be used to evacuate or pump down a heat pump or air conditioning system.

**NOTICE**  
 THIS UNIT IS SHIPPED WITH A NITROGEN/HELIUM HOLDING CHARGE ONLY. UNIT MUST BE EVACUATED AND CHARGED PER INSTALLATION INSTRUCTIONS WITH REFRIGERANT LISTED ON SERIAL RATING PLATE.

**NOTICE**  
 UNITS SHIPPED WITH A HOLDING CHARGE ARE INTENDED FOR COMPONENT REPLACEMENT ONLY ON EXISTING SYSTEMS, AND NOT INTENDED FOR USE IN NEW SYSTEMS OR NEWLY CONSTRUCTED HOMES.

**NOTICE**  
 UNITS MUST ONLY BE USED AS REPLACEMENT COMPONENTS FOR PRE-2010 INSTALLED SYSTEMS.

**NOTE:** Holding charge must be removed before brazing.

**CAUTION**  
 Prolonged operation at suction pressures less than 20 psig for more than 5 seconds will result in overheating of the scrolls and permanent damage to the scroll tips, drive bearings and internal seal.

1. Open service valves before attaching vacuum pump.
2. Connect the vacuum pump with 250 micron capability to the service valves.
3. Evacuate the system to 250 microns or less using suction **and** liquid service valves. Using both valves is necessary as some compressors create a mechanical seal separating the sides of the system.
4. Close pump valve and hold vacuum for 10 minutes. Typically pressure will rise during this period.

- If the pressure rises to 1000 microns or less and remains steady the system is considered leak-free; proceed to startup.

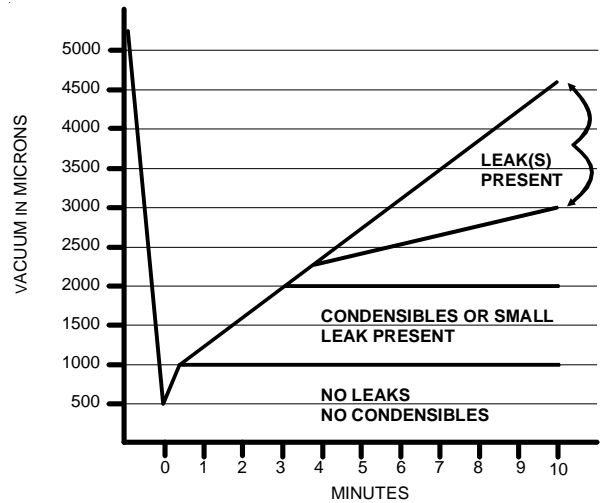

- If pressure rises above 1000 microns but holds steady below 2000 microns, moisture and/or noncondensibles may be present or the system may have a small leak. Return to step 2: If the same result is encountered check for leaks as previously indicated and repair as necessary then repeat evacuation.
- If pressure rises above 2000 microns, a leak is present. Check for leaks as previously indicated and repair as necessary then repeat evacuation.

### Electrical Connections

**WARNING**  
**HIGH VOLTAGE!**  
 Disconnect ALL power before servicing. Multiple power sources may be present. Failure to do so may cause property damage, personal injury or death due to electric shock. Wiring must conform with NEC or CEC and all local codes. Undersized wires could cause poor equipment performance, equipment damage or fire.

**WARNING**  
 To avoid the risk of fire or equipment damage, use copper conductors.

**NOTICE**  
 Units with reciprocating compressors and non-bleed TXV's require a Hard Start Kit.

The condensing unit rating plate lists pertinent electrical data necessary for proper electrical service and overcurrent protection. Wires should be sized to limit voltage drop to 2% (max.) from the main breaker or fuse panel to the condensing unit. Consult the NEC, CEC, and all local codes to determine the correct wire gauge and length.

Local codes often require a disconnect switch located near the unit; do not install the switch on the unit. Refer to the installation instructions supplied with the indoor furnace/air handler for specific wiring connections and indoor unit configuration. Likewise, consult the instructions packaged with the thermostat for mounting and location information.

### Overcurrent Protection

The following overcurrent protection devices are approved for use.

- Time delay fuses
- HACR type circuit breakers

These devices have sufficient time delay to permit the motor-compressor to start and accelerate its load.

### Three Phase Compressor Rotation

**CAUTION** Use care when handling scroll compressors. Dome temperatures could be hot.

Three phase compressors are power phase dependent and can rotate in either direction.

Verify proper rotation for three phase compressors by ensuring the suction pressure drops and discharge pressure rises when the compressor is energized. **NOTE:** When operated in reverse, a three phase scroll compressors is noisier and its current draw substantially reduced compared to marked values.

To correct, disconnect power and switch any two leads at the unit contactor and re-observe.

### High Voltage Connections

Route power supply and ground wires through the high voltage port and terminate in accordance with the wiring diagram provided inside the control panel cover.

### Low Voltage Connections

Condensing unit control wiring requires 24 Volt minimum, 25VA service from the indoor transformer. Route control wires through the low voltage port and terminate in accordance with the wiring diagram provided inside the control panel cover.

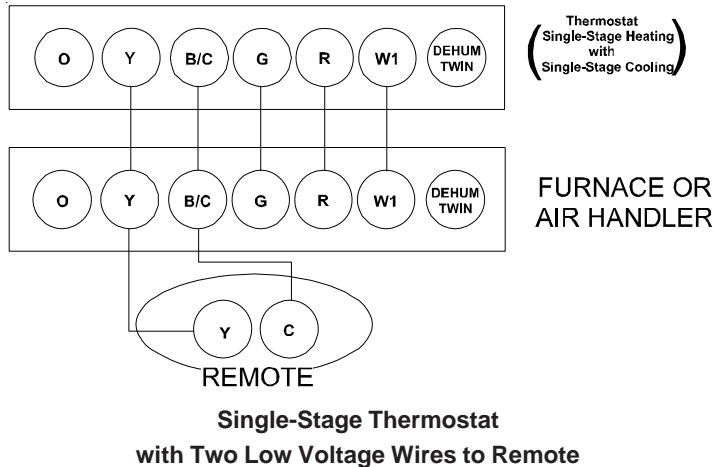

## System Start Up

**CAUTION** POSSIBLE REFRIGERANT LEAK  
To avoid a possible refrigerant leak, open the service valves until the top of the stem is 1/8" from the retainer.

When opening valves with retainers, open each valve only until the top of the stem is 1/8" from the retainer. To avoid loss of refrigerant, DO NOT apply pressure to the retainer. When opening valves without a retainer remove service valve cap and insert a hex wrench into the valve stem and back out the stem by turning the hex wrench counterclockwise. Open the valve until it contacts the rolled lip of the valve body.

**NOTE:** These are not back-seating valves. It is not necessary to force the stem tightly against the rolled lip.

The service valve cap is the secondary seal for the valves and must be properly tightened to prevent leaks. Make sure cap is clean and apply refrigerant oil to threads and sealing surface on inside of cap. Tighten cap finger-tight and then tighten additional 1/6 of a turn (1 wrench flat), or to the following specification, to properly seat the sealing surfaces.

1. 3/8" valve to 5 - 10 in-lbs
2. 5/8" valve to 5 - 20 in-lbs
3. 3/4" valve to 5 - 20 in-lbs
4. 7/8" valve to 5 - 20 in-lbs

Do not introduce liquid refrigerant from the cylinder into the crankcase of the compressor as this may damage the compressor.

**CAUTION** POSSIBLE REFRIGERANT LEAK  
To avoid a possible refrigerant leak, open the service valves until the top of the stem is 1/8" from the retainer.

**NOTICE** REFRIGERANT MUST BE ADDED TO THE SYSTEM AFTER EVACUATION IS COMPLETE.

**WARNING** REFRIGERANT UNDER PRESSURE!  
• Do not overcharge system with refrigerant.  
• Do not operate unit in a vacuum or at negative pressure.  
Failure to follow proper procedures may cause property damage, personal injury or death.

1. Add refrigerant amount shown in table below for the unit being installed.

Models	Nominal Charge <sup>‡</sup> (oz.)
GSC13018	75
GSC13024	77
GSC13030	66
GSC13036	77
GSC13042	95
GSC13048	89
GSC13060	131

<sup>‡</sup> Approximate charge shown for 15' of 3/8" liquid line. System charge must be adjusted per final charge adjustment (Page 7.)

- Set thermostat to call for cooling. Check indoor and outdoor fan operation and allow system to stabilize for 10 minutes for fixed orifices and 20 minutes for expansion valves.

### Charge Verification



#### WARNING

##### REFRIGERANT UNDER PRESSURE!

- Do not overcharge system with refrigerant.
- Do not operate unit in a vacuum or at negative pressure.

Failure to follow proper procedures may cause property damage, personal injury or death.



#### CAUTION

Use refrigerant certified to AHRI standards. Use of used refrigerant may cause compressor damage that is not covered under warranty. Most portable machines cannot clean used refrigerant to meet AHRI standards.

#### NOTICE

Violation of EPA regulations may result in fines or other penalties.



#### CAUTION

Operating the compressor with the suction valve closed may cause serious compressor damage.

### Final Charge Adjustment

The outdoor temperature must be 60°F or higher. Set the room thermostat to COOL, fan switch to AUTO, and set the temperature control well below room temperature.

After system has stabilized per startup instructions, check subcooling and superheat as detailed in the following section.

### Fixed Orifice



#### CAUTION

To prevent personal injury, carefully connect and disconnect manifold gauge hoses. Escaping liquid refrigerant can cause burns. Do not vent refrigerant into the atmosphere. Recover all refrigerant during system repair and before final unit disposal.

- Purge gauge lines. Connect service gauge manifold to base-valve service ports. Run system at least 10 minutes to allow pressure to stabilize.
- Temporarily install thermometer on suction (large) line near suction line service valve with adequate contact and insulate for best possible reading.
- Refer to the superheat table provided for proper system superheat. Add charge to lower superheat or recover charge to raise superheat.
- Disconnect manifold set, installation is complete.  
Superheat Formula = Suct. Line Temp. - Sat. Suct. Temp.

### Expansion Valve System

- Purge gauge lines. Connect service gauge manifold to base-valve service ports. Run system at least 10 minutes to allow pressure to stabilize.
- Temporarily install thermometer on liquid (small) line near liquid line service valve with adequate contact and insulate for best possible reading.
- Check subcooling and superheat. Systems with TXV application should have a subcooling of  $7 \pm 2$  °F and superheat of  $8 \pm 1$  °F.
  - If subcooling and superheat are low, **adjust** TXV to  $8 \pm 1$  °F superheat, then check subcooling.

**NOTE:** To adjust superheat, turn the valve stem clockwise to increase and counter clockwise to decrease.

b. If subcooling is low and superheat is high, **add** charge to raise subcooling to  $7 \pm 2$ °F then check superheat.

c. If subcooling and superheat are high, **adjust** TXV valve to  $8 \pm 1$  °F superheat, then check subcooling.

d. If subcooling is high and superheat is low, **adjust** TXV valve to  $8 \pm 1$  °F superheat and **remove** charge to lower the subcooling to  $7 \pm 2$ °F.

**NOTE:** Do **NOT** adjust the charge based on suction pressure unless there is a gross undercharge.

- Disconnect manifold set, installation is complete.  
Subcooling Formula = Sat. Liquid Temp. - Liquid Line Temp.

**NOTE:** Check the Schrader ports for leaks and tighten valve cores if necessary. Install caps finger-tight.

SYSTEM SUPERHEAT									
Outdoor Dry Bulb Temperature, °F	Indoor Wet Bulb Temperature, °F								
	55	57	59	61	63	65	67	69	71
60	10	13	17	20	23	26	29	30	31
65	8	11	14	16	19	22	26	27	29
70	5	8	10	13	15	19	23	24	25
75	----	----	6	9	11	15	20	21	23
80	----	----	----	----	7	12	17	18	20
85	----	----	----	----	----	8	13	15	16
90	----	----	----	----	----	5	10	11	13
95	----	----	----	----	----	----	5	8	10
100	----	----	----	----	----	----	----	5	8
105	----	----	----	----	----	----	----	----	5
110	----	----	----	----	----	----	----	----	----
115	----	----	----	----	----	----	----	----	----

SATURATED SUCTION PRESSURE TEMPERATURE CHART	
SUCTION PRESSURE	SATURATED SUCTION TEMPERATURE °F
PSIG	R-22
50	26
52	28
54	29
56	31
58	32
60	34
62	35
64	37
66	38
68	40
70	41
72	42
74	44
76	45
78	46
80	48
85	50
90	53
95	56
100	59
110	64
120	69
130	73
140	78
150	83
160	86
170	90

SATURATED LIQUID PRESSURE TEMPERATURE CHART	
LIQUID PRESSURE	SATURATED LIQUID TEMPERATURE °F
PSIG	R-22
200	101
210	105
220	108
225	110
235	113
245	116
255	119
265	121
275	124
285	127
295	130
305	133
325	137
355	144
375	148
405	155
415	157
425	n/a
435	n/a
445	n/a
475	n/a
500	n/a
525	n/a
550	n/a
575	n/a
600	n/a
625	n/a



# Troubleshooting Information

Complaint	No Cooling						Unsatisfactory Cooling				System Operating Pressures				Test Method Remedy	
	SYMPTOM															
<b>POSSIBLE CAUSE</b> <b>DOTS IN ANALYSIS GUIDE INDICATE "POSSIBLE CAUSE"</b>	System will not start	Compressor will not start - fan runs	Compressor and Condenser Fan will not start	Evaporator fan will not start	Condenser fan will not start	Compressor runs - goes off on overload	Compressor cycles on overload	System runs continuously - little cooling	Too cool and then too warm	Not cool enough on warm days	Certain areas to cool others to warm	Compressor is noisy	Low suction pressure	Low head pressure	High suction pressure	High head pressure
Power Failure	•															Test Voltage
Blown Fuse	•		•	•												Impact Fuse Size & Type
Loose Connection	•		•	•	•	•										Inspect Connection - Tighten
Shorted or Broken Wires	•	•	•	•	•	•										Test Circuits with Ohmmeter
Open Overload				•	•											Test Continuity of Overloads
Faulty Thermostat	•		•	•				•								Test Continuity of Thermostat and Wiring
Faulty Transformer	•		•													Check Control Circuit with Voltmeter
Shorted or Open Capacitor		•		•	•	•										Test Capacitor
Internal Compressor Overload Open		•														Test Continuity of Overload
Shorted or Grounded Compressor		•				•										Test Motor Windings
Compressor Stuck	•					•										Use Test Cord
Faulty Compressor Contactor	•	•	•			•										Test Continuity of Coil and Contacts
Faulty Fan Relay				•												Test Continuity of Coil and Contacts
Open Control Circuit																Test Control Circuit with Voltmeter
Low Voltage		•				•	•									Test Voltage
Faulty Evaporator Fan Motor				•									•			Repair or Replace
Shorted or Grounded Fan Motor				•	•										•	Test Motor Windings
Improper Cooling Anticipator								•								Check Resistance of Anticipator
Shortage or Refrigerant							•	•					•	•		Test For Leaks, Add Refrigerant
Restricted Liquid Line							•	•					•	•		Replace Restricted Part
Undersized Liquid Line							•		•				•			Replace Line
Undersized Suction Line													•			Replace Line
Not Enough Air across Indoor Coil							•		•	•			•			Speed Blower, Check Duct Static Pressure
Too Much Air across Indoor Coil														•		Reduce Blower Speed
Overcharge of Refrigerant						•	•							•	•	Recover Part of Charge
Noncondensibles							•		•						•	Recover Charge, Evacuate, Recharge
Recirculation of Condensing Air							•		•						•	Remove Obstruction to Air Flow
Infiltration of Outdoor Air							•		•	•						Check Windows, Doors, Vent Fans, Etc.
Improperly Located Thermostat								•								Relocate Thermostat
Air Flow Unbalanced								•		•						Readjust Air Volume Dampers
System Undersized							•		•							Refigure Cooling Load
Broken Internal Parts															•	Replace Compressor
Broken Valves															•	Test Compressor Efficiency
Inefficient Compressor							•						•	•		Test Compressor Efficiency
High Pressure Control Open			•													Reset and Test Control
Unbalanced Power, 3PH		•				•	•									Test Voltage
Wrong Type Expansion Valve						•	•		•							Replace Valve
Expansion Valve Restricted						•	•	•	•				•	•		Replace Valve
Oversized Expansion Valve													•		•	Replace Valve
Undersized Expansion Valve						•	•	•	•				•			Replace Valve
Expansion Valve Bulb Loose						•	•						•		•	Tighten Bulb Bracket
Inoperative Expansion Valve						•	•						•			Check Valve Operation
Loose Hold-down Bolts															•	Tighten Bolts

For detailed service information refer to the Remote Condensing Unit Service manual.

## NOTICE

UNITS WITH ROTARY OR RECIPROCATING COMPRESSORS AND NON-BLEED TXV'S REQUIRE A HARD START KIT.

THIS PAGE INTENTIONALLY LEFT BLANK

THIS PAGE INTENTIONALLY LEFT BLANK

**NOTE: SPECIFICATIONS AND PERFORMANCE DATA LISTED HEREIN ARE SUBJECT TO CHANGE WITHOUT NOTICE**

**Quality Makes the Difference!**

All of our systems are designed and manufactured with the same high quality standards regardless of size or efficiency. We have designed these units to significantly reduce the most frequent causes of product failure. They are simple to service and forgiving to operate. We use quality materials and components. Finally, every unit is run tested before it leaves the factory. That's why we know. . . **There's No Better Quality.**

Visit our website at [www.goodmanmfg.com](http://www.goodmanmfg.com) or [www.amana-hac.com](http://www.amana-hac.com) for information on:

- Products
- Warranties
- Customer Services
- Parts
- Contractor Programs and Training
- Financing Options

© 2010 - 2011 Goodman Manufacturing Company, L.P.