

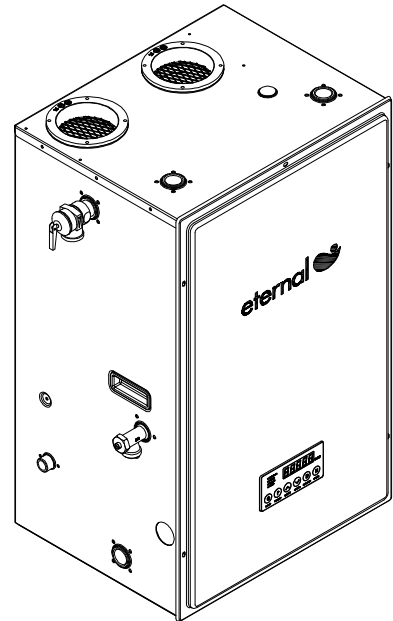

Installation • Operation Manual

Natural Gas (NG) - Factory Default
 Liquid Propane Gas (LPG) - Optional Orifice

Model GU100 / 508(11,12,21,22)1100



Quality
 ISO 9001



Service Information Center:

Call us first if you have any questions with this product. We can help you with questions about assembly and Water Heater operation or if there are any damaged or missing parts when you unpack this unit from the shipping box. Please call before returning to the store.

1-866-946-1096

8am-4pm CST, Monday through Friday

IMPORTANT:

- **Only specially trained and authorized personnel are permitted to service this water heater.**
- **NOTE TO ASSEMBLER / INSTALLER:**
 Leave this manual with the consumer.
- **NOTE TO CONSUMER:**
 Keep this manual for future reference.
- **RECORD YOUR SERIAL # _____**
 (see silver CSA label on Gas Water Heater)



WARNING



Read this Operator's Manual carefully and be sure your Water Heater is properly assembled, installed and maintained. Failure to follow these instructions exactly could result in fire, explosion, serious bodily injury and/or property damage.

Do not store or use gasoline or other flammable vapors and liquids in the vicinity of this or any other appliance.



WARNING



California Proposition 65 lists chemical substances known to the state to cause cancer, birth defects, death, serious illness or other reproductive harm. This product may contain such substances, be their origin from fuel combustion (gas, oil) or components of the product itself.



WARNING











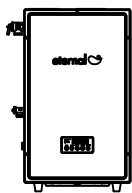



Only a licensed professional can install Eternal units for safety and code compliance. Venting and plumbing codes can vary by location. Installation instructions and all applicable codes must be followed or property damage, severe injury, or death may result. Failure to use a licensed plumber or contractor, follow venting, plumbing, and building codes; or follow installation instructions may be unlawful and will void the product warranty. Grand Hall is not responsible for any costs incurred for repairing any problems resulting from failure to follow installation instructions or applicable codes.

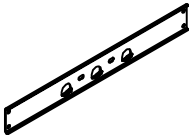
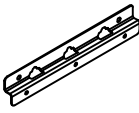
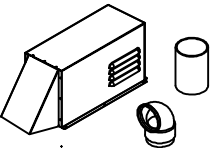

Table of Contents

Included & Optional Accessories	P3
Specifications	P4
Dimensions	P5
Parts & Service Parts List	P6~8
Pre-Installation Instructions for Your Safety	P9
Installation Preparation	P10
Condensate Disposal	P11
Indoor & Outdoor Installation	P12~13
Mobile Home Installation & EC Adapter Installation	P14
Wall & Floor Mounting	P15~16
Venting Intake & Exhaust Material	P17
Venting Specification	P18
Vertical & Horizontal Termination	P19~20
Clearance Requirements from Vent Terminations to Building Openings	P21
Concentric Vent Kit & Outdoor Vent Kit Installation	P22
Vent Pipe Installation & Terminator Position	P23
Gas Supply Piping	P24
LP Conversion	P25
Water Supply Connection	P26
Condensate Piping	P27
Temperature and Pressure Relief Valve	P28
Electrical Connection	P29
Optional Remote Controller Installation	P30~31
Plumbing Diagrams	P32
Operating Instructions	P33
How To Use The Front Control Interface	P34
How To Use the Remote Controller & Ignition Cycle Counter	P35
Maintenance and Service	P36
"D" button Diagnostic Function	P37
Diagnostics	P38~40
How To Check Gas Combustion	P41~42
Wiring and Connection Diagram	P43
Grand Hall Limited Warranty	P44~46

Included Accessories

P/N	Item	Description	Qty	P/N	Item	Description	Qty
508111100	GU100 Eternal Hybrid Condensing Water Heater		1	157010126	Propane Gas Label		1
				194140151	T&P Relief Valve		1
157290081	Operating and Installation Manual Registration Card		1	305070273	Drain Valve Assembly		1
157140188							
314070066	Mounting Bracket Assembly	 190006019 1/4"x1 1/2" screws x6pcs	1	151140097	Mesh Screen		2
				150150197	LP Orifice		1
				195140195	T-Fitting (for condensate line)		1
		 151140067 Wall Bracket x1pcs			 151140066 Mounting Bracket x2pcs		
152140230	Intake Orifice $\varnothing 32$ (for NG application installing at elevation over 3,000 ft)		1	312070025	EC Adapter		1
195140180	Hole Plug		1	150290239	1/2" Bushing		1

Optional Accessories

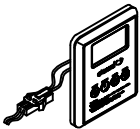
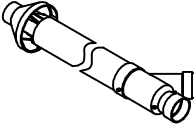
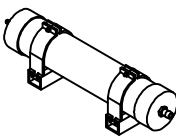
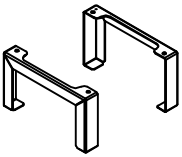
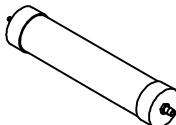
P/N	Item	Description	Qty	P/N	Item	Description	Qty
314070282	Outdoor Venting Cap		1	151140130	Horizontal Terminator 3"		1
314070039	Remote Controller Kit	 Self Tapping Screw 5/32" x 5/8" : 2pcs	1	ECHCVT02	Concentric Kit		1
				ECHNK02	Eternal Condensate Neutralizer Kit		1
314080136	Water Heater Stand	 Philips Head Screw M8x15 : 4pcs Stainless Steel Expansion Bolt : 4pcs	1	ECHNR02	Eternal Condensate Neutralizer Refill		1

Eternal Hybrid Water Heater Technical Specifications

Model Name		GU100	
Thermal Efficiency (*) / Energy Factor		96% NG / 97% LP / 0.94 Energy Factor	
Installation		Indoor / Outdoor / Wall Hung / Floor Standing	
Flue System		Forced Exhaust Power or Direct Vent	
Vent Run	3" PVC	Up to 100ft, 6 Elbows Max, 5ft Deduction Per Elbow	
Condensate Discharge	Low Fire / Med Fire / High Fire	0.5GPH / 1.1GPH / 1.75GPH	
Condensate pH Level		4 pH	
Gas Type		Pre-set for NG / LP Conversion Kit Included	
Unit Connections	Gas / Water Fitting	1/2" Female NPT / 3/4" Female NPT	
	Electricity	Dedicated 120VAC, 60Hz w/3 Pronged Power Cord	
Gas Input Rate	Min / Max	16,000 BTU/Hr / 100,000 BTU/Hr	
Gas Supply Pressure	NG / LP	3.5" WC to 10.5" WC / 8" WC to 14" WC	
Manifold Pressure (minimum)	Honeywell	NG	(-) 0.01" W.C.
		PG	(-) 0.01" W.C.
Ignition System		Direct electronic Ignition and Automatic Flame Sensing	
Burner System		Single Orifice Fuel Injection/ Pre-mixing Metal fiber Infrared Burner	
Gas Valve System		Dual Stage Negative Pressure Full Modulation Air Ratio valve	
Internal Piping Material		PPS + Copper	
Reserve Tank		Under 2 Gallons	
Electrical Consumption		Standby 8W, Max 45W	
Maximum Noise Level		Under 35dB (a)	
Remote Controller		Up to 3 kits	
Multi Unit Capable		Up to 2 in manifold	
GPM Capacity Range		0.1 to 10.0 GPM	
Temperature Sensing		Tank, Cold Inlet, Hot Outlet, Air Thermistors	
Temperature Control		Simulation Feed Forward and Feed Back, Computer Controlled Mixing Valve	
Flow Sensing		Dual Flow Sensors w/Built-in GPM Monitor	
Temperature Settings Range		100°F to 140°F in 5°F Steps	
Unit Dimensions (WxHxD)		16.9" x 29.1" x 13.8"	
Unit Weight		74.5lbs	
Safety Devices		T&P Valve, Flame Rod, Thermal Fuse(306°F), Remaining Flame Detection, Fan RPM Check, Freeze Protection(-40°F), Vent Blockage Detection, Thermostat Switches(149°F / 194°F), Gas Valve Current Leak Detection, Ignition Prevention, Dipswitch Temperature Lock, GFCI w/2 x 5A Fuses.	

- * GU100 is for single or dual unit applications with no multi control unit.
- * Maximum manifold pressure is indicated on the rating label on right side of the unit.
- * Independent DOE tested.

Dimensions - GU100 / 508(11,12,21,22)1100

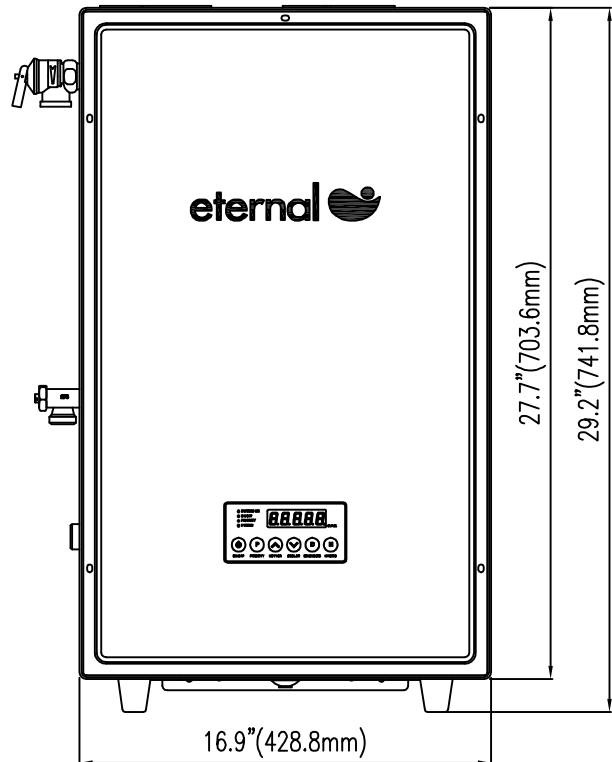
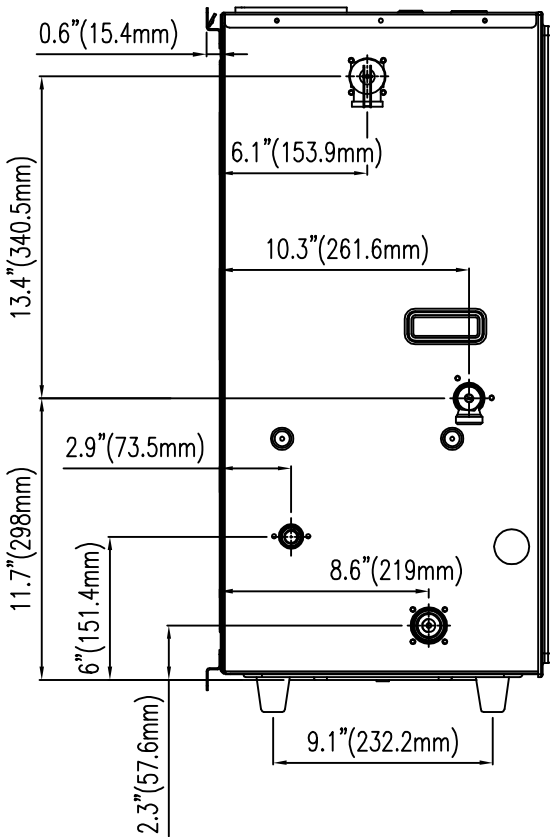
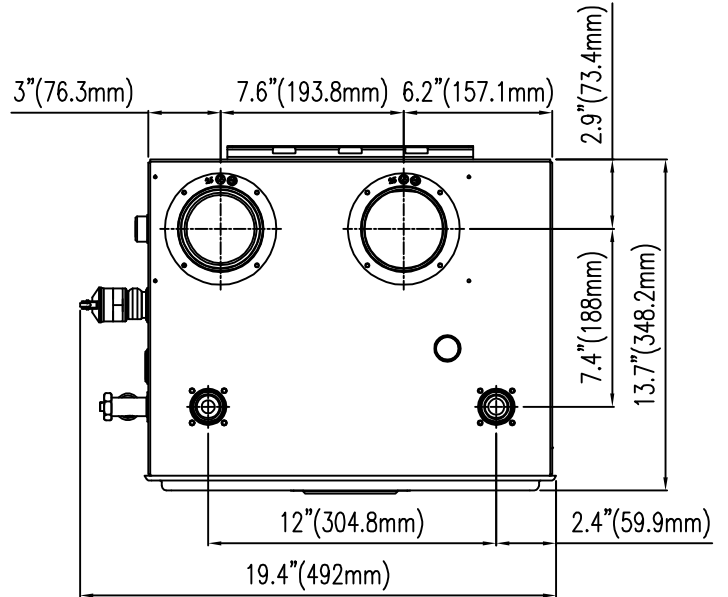

Parts Diagram for Model GU100 / 508(11,12,21,22)1100

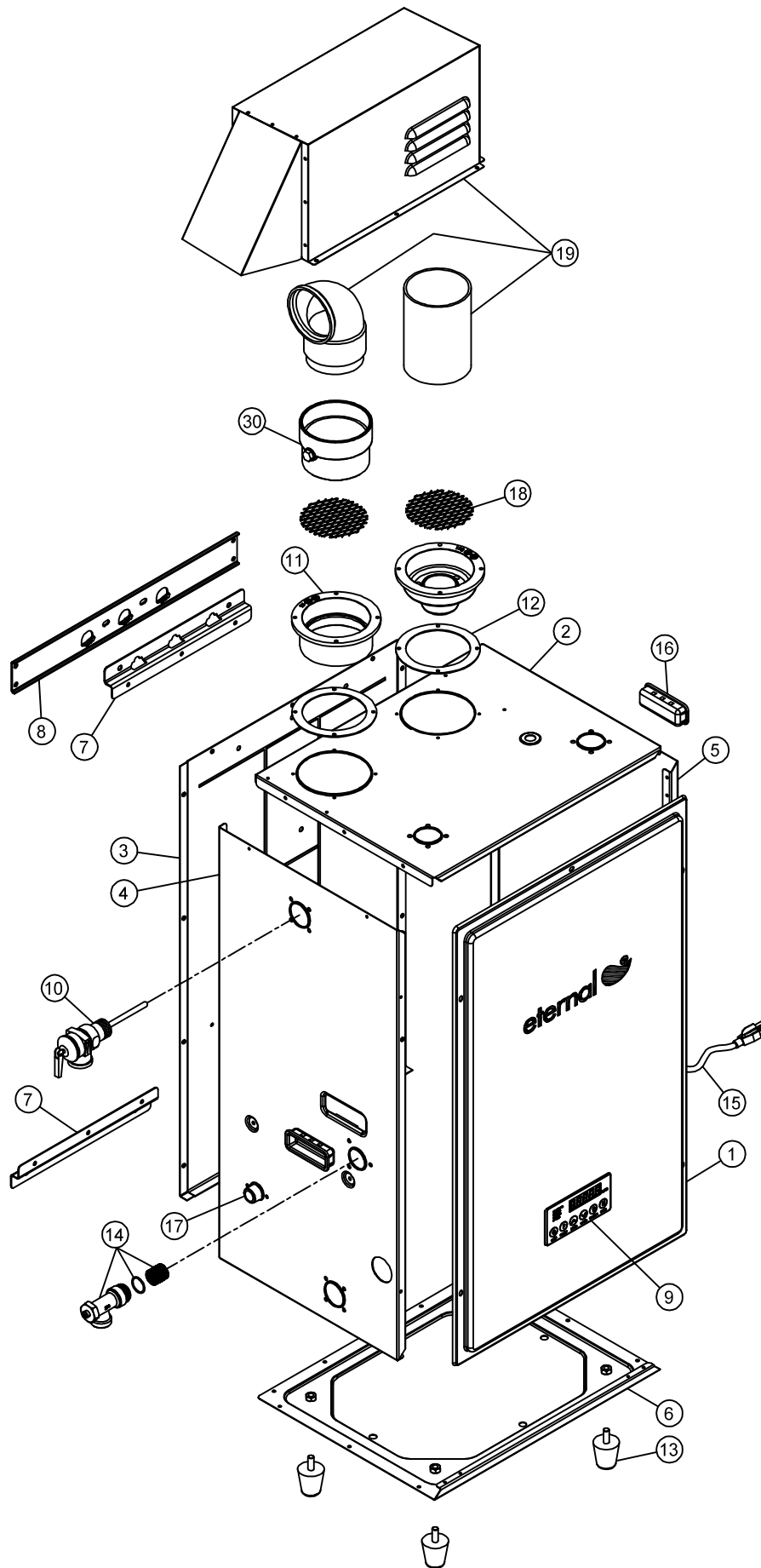

Parts Diagram for Model GU100 / 508(11,12,21,22)1100

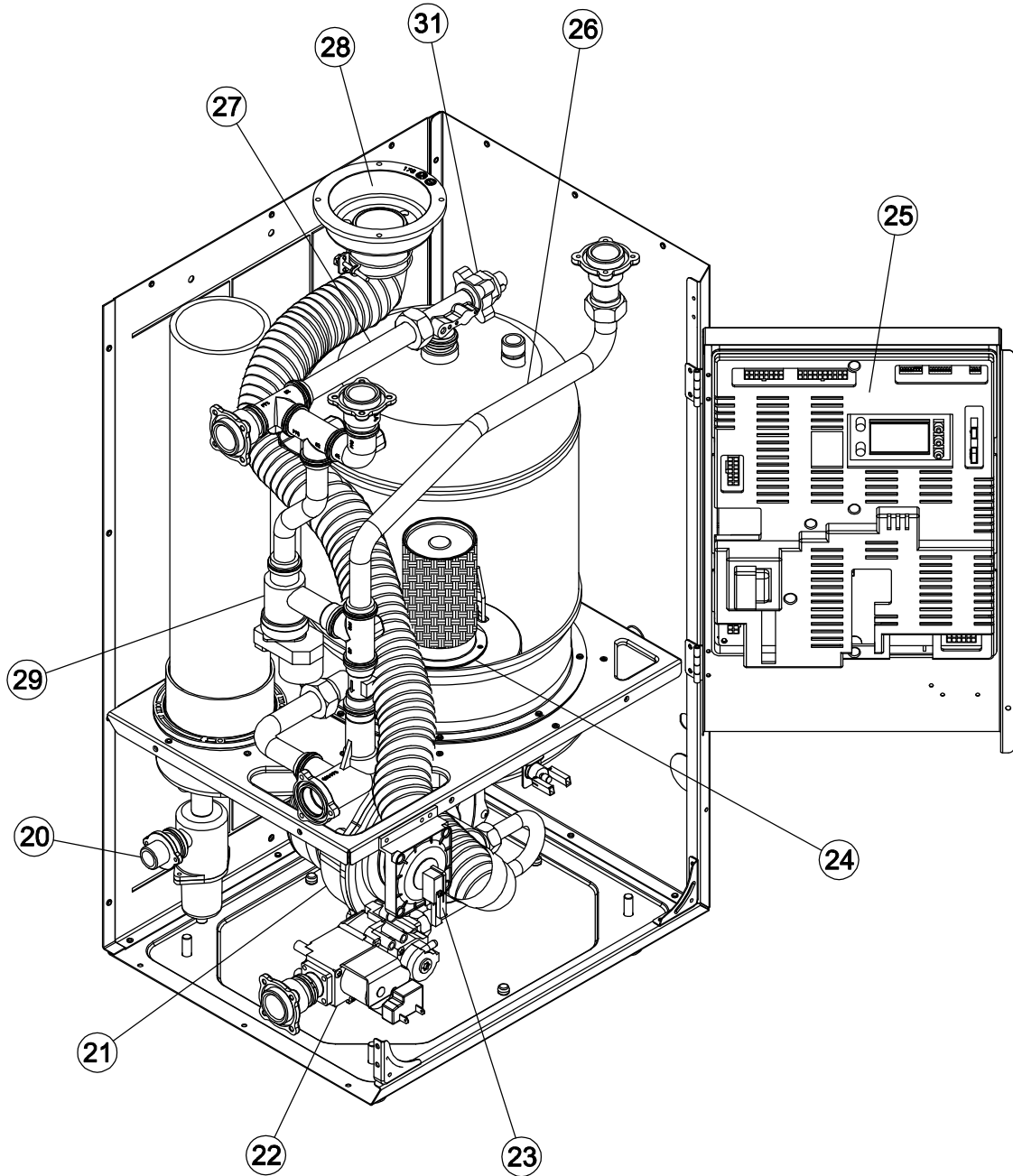

Parts List for Model GU100 / 508(11,12,21,22)1100

KEY	DESCRIPTION
1	Panel, Front Assembly
2	Panel, Top / Rear Assembly
3	Panel, Rear
4	Panel, Left Assembly
5	Panel, Right Assembly (GU100)
6	Panel, Bottom
7	Mounting Bracket
8	Wall Bracket
9	Controller / Front
10	T&P Relief Valve (Cash Acme)
11	Vent Collar
12	Vent Collar Packing
13	Rubber Foot
14	Drain Valve Assembly
15	Main Power Cord
16	Handle
17	Condensing Nipple
18	Mesh Screen
19	Outdoor Venting Cap (Optional)
20	Trap Cleaner Assembly
21	Radial Blower Assembly
22	Gas Valve
23	Air Pressure Switch (GU100)
24	Burner Assembly
25	Main Controller (GU100)
26	Cold Water Tube Assembly (GU100)
27	Hot Water Tube Assembly (GU100)
28	Flexible Silencer Kit
29	Mixing Valve
30	EC Adapter
31	Water Pressure Switch

Pre-Installation Instructions for Your Safety



WARNING



If you do not follow these instructions exactly, a fire or explosion could result causing property damage, personal injury or loss of life.

Installation Codes

- The installation must conform with local codes or, in the absence of local codes, with National Fuel Gas Code, ANSI Z223.1/NFPA 54.
- Properly ground the unit in accordance with all local codes or in the absence of local codes, with the National Electrical Codes, ANSI/NFPA 70.

Before Installation

- This water heater does not have a pilot. It is equipped with an ignition device that automatically lights the burner. Do not try to light the burner by hand.
- Smell all around the water heater area for evidence of leaking gas. Be sure to smell next to the floor because LP gas is heavier than air and will settle on the floor.
- Use only your hand to turn the manual gas valve knob. Never use tools. If the knob will not turn by hand, don't try to repair it. Call a qualified service technician. Force or attempted repair could result in a fire or explosion.
- Do not use this water heater if any part has been under water. Immediately call a qualified service technician to inspect the water heater and to replace any damaged parts.



WARNING



WHAT TO DO IF YOU SMELL GAS

- Do not try to light any appliance.
- Do not touch any electrical switch; do not use any phone in your building.
- Immediately call your gas supplier from a neighbor's phone. Follow the gas supplier's instructions.
- If you cannot reach your gas supplier, call the fire department.

TO TURN OFF GAS TO WATER HEATER

- Turn off all electrical power to the water heater if service is to be performed.
- Turn the manual gas valve located on the outside of the unit clockwise to the off position.

Vapors from flammable liquids will explode and catch fire causing death or severe burns. Do not use or store flammable products such as gasoline, solvents or adhesives in the same room or area near the water heater.

Keep flammable products

- Far away from water heater
- In approved containers
- Tightly closed
- Out of children's reach

Vapors

- Cannot be seen
- Vapors are heavier than air
- Go a long way on the floor
- Can be carried from other rooms to the main burner by air currents

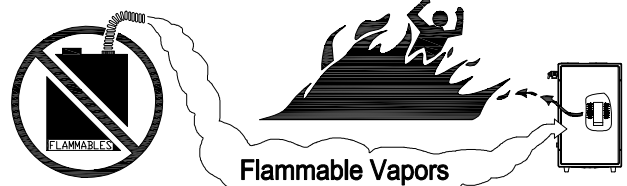

WARNING



Use this water heater at your own risk. The set outlet water temperature can cause severe burns instantly or death from scalds. Test the water before bathing or showering. Do not leave children or the infirm without supervision.



NOTICE



Each eternal is equipped with a computer controlled mixing valve to ensure precise temperature is being delivered. Modulation noise is normal and should not be concerned.

Installation Preparation

Unpacking Your Eternal Water Heater



- Unpack the unit carefully and make sure that all accessories are put aside so they will not be lost.
 - Operator's manual
 - Warranty Registration Card
 - Included Parts
- Inspect the water heater for possible shipping damages.



Additional Safety Instructions



- Check the markings of the rating plate on the water heater to be certain the type of gas being furnished corresponds to what the water heater is equipped for.
- Do not connect this water heater to a fuel type not in accordance with the rating plate.
 - Read the Safety guidelines in the beginning of this manual.
 - The internal computer controlled regulator is preset by the manufacturer and should not be adjusted by user.
 - Maintain proper space around the unit for servicing. Install the unit so that it can be connected or removed easily.
 - The electrical connection requires a means for switching off the power supply.
 - Avoid installing the unit in an area with high levels of dust, sand, or debris. These particles may clog the air vent or impair the function of the fan, leading to improper combustion. Regular maintenance is needed.
 - Do not install the unit where the exhaust vent is pointing into any opening in a building or where the noise may disturb neighbors.

WATER HEATER PLACEMENT

- Carefully choose the location for the new heater as placement is a very important consideration for the safety of the occupants in the building and for the most economical use of the appliance.
- Whether replacing an old water heater or putting the water heater in a new location, consider the following critical points:
 - The location selected should be as close to the vent termination point as possible, and centered within the water piping system for best hot water delivery. All water heaters can leak. Do not install without adequate drainage provisions where water flow can cause property damage.
 - If vented through an outside wall or through the roof using 3" vent piping the total vent run cannot exceed 95 feet with one 90° elbow. If more elbows are required the venting distance must be reduced 5 feet for every 90° elbow.
 - Vent piping should slope downward towards the unit. Horizontal runs require adequate support at 3½ feet intervals and vertical runs supported at 5 feet intervals.
 - Condensation may be created at times as the combustion gases exit the vent cap. Discoloration of surfaces in proximity to the vent cap may occur.

	CAUTION	
Before Commencing The Installation		
Check that it is in accordance with relevant building and mechanical codes, as well as any local, state or federal regulations.		

	CAUTION	
		
The drain valve must be tightened by Hand ONLY, not by tools of any kind.		

	WARNING	
<ul style="list-style-type: none"><input type="checkbox"/> The appliance should be located in an area where leakage of the tank or connections will not result in damage to the area adjacent to the appliance or to lower floors of the structure. When such locations cannot be avoided, it is recommended that a suitable drain pan be installed under the appliance. The pan must not restrict combustion air flow.<input type="checkbox"/> The minimum inlet gas pressure must be within the value specified by the manufacturer and the minimum value listed is only for the purpose of input adjustment.<input type="checkbox"/> If a water heater is installed in a closed water supply system, such as one having a backflow preventer in the cold water supply line and a thermal expansion tank is required, contact the water supplier or local plumbing inspector on how to control this situation.<input type="checkbox"/> The Temperature and Pressure (T&P) relief valve must be certified as meeting the requirement of the Standard for Relief Valves and Automatic Gas Shut-off Devices for Hot Water Supply Systems ANSI Z21.22/CAN1-4.4. The valve must be marked with a maximum set pressure not to exceed the marked hydrostatic working pressure of the water heater (150 psi) and a discharge capacity not less than the water heater input rate as marked on the rating plate.		

Condensate Disposal



CAUTION



The condensate drain must be filled and unobstructed to allow flow of condensate. The condensate should not be subjected to conditions where freezing could occur. If the condensate is subjected to freezing or obstruction, it can leak, resulting in potential water damage to the unit and surrounding area.

The condensate trap must be filled with water prior to using the water heater.

- Fill water down the exhaust collar until water visibly flow out of condensate drain before first use.

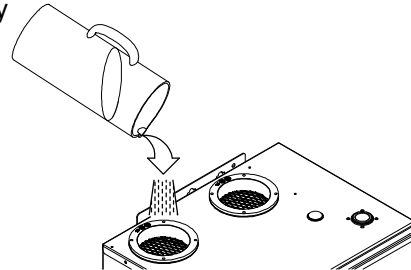

Figure 1.



NOTICE



The drain line material must be an approved material by the authority having jurisdiction. In absence of such authority, PVC and CPVC piping must comply with ASTM D1785 or D2846. This pipe must be connected to the port at the side panel. The end of the pipe should drain to a laundry tub or to a floor drain.

1/2" PVC (SCH40, ASTM-D1785)
or
3/4" CPVC (SDR11, ASTM-D2846)

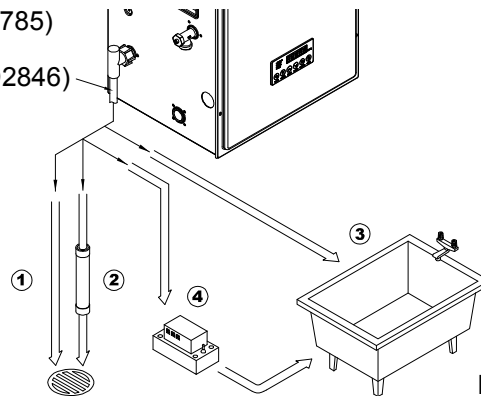

Figure 2.



NOTICE



Eternal water heater will typically produce a condensate that is considered slightly acidic with a Ph content of approximately 3-4. Install a neutralizing filter if required by authority having jurisdiction (See figure 2).

1. Direct to drain from the unit.
2. Drain through neutralizer from the unit.
3. Drain to laundry tub from the unit, in this case the unit must be above the height of the laundry tub.
4. When installing a condensate pump, ensure the pump is approved for use with condensing appliance.

The pump should be equipped with an overflow switch to prevent property damage from potential condensate spillage.

CLEANING OUT THE TRAP

Over time, blockage of the trap by debris may occur; when the condensate cannot be released, the unit will go into error and will shut down. When this occurs, the trap must be cleaned.

To Remove Trap

1. Gently pull trap body downwards to remove.
2. Remove clip securing trap to the nipple.

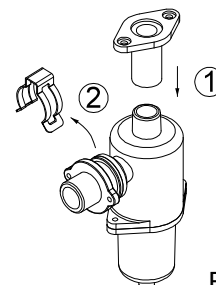

Figure 3.

Indoor Installation

Clearances

From top of water heater	12 inches	From back of unit	0.6 inch
From front of unit	6 inches (*)	From left side of unit (gas piping side)	6 inches
From side wall flue or vent connector in any direction	6 inches	From right side of unit	2 inches

*For accessibility when performing maintenance, 24" clearance in front of the unit it is recommended.

Combustion Air Supply

- GU100 can be used as either Power-Vent or Direct-Vent appliance. When used as a Power-Vent appliance, the water heater should be located in an area where enough air is available for proper combustion and ventilation. Follow the latest edition of ANSI Z223.1 and any of your local codes that are applicable.
- GU100 is a Category IV vented appliance and manufacturer's ventilation specifications should be followed.
- In general these requirements specify that if the unit is installed in a confined space, there must be permanent air supply openings if Eternal isn't installed as Direct-Vent.



WARNING - high elevation installations



Natural gas in high altitude might contain less heating value than typical 1100 BTU/ cuft and therefore can cause improper air / gas mix leading to improper combustion. For natural gas installations in altitudes above 3,000 feet, be sure to apply the intake orifice (P/N 152140230) provided by manufacturer in the accessory box.

Minimum Recommended Air Supply To Water Heater as Power-Vent

Model #	Water Heater Capacity	Outside Air Area	Inside Air Area
GU100	Max. 100,000 Btu/hour	7 sq.in.	27 sq.in.

Air supply from outside building:

When combustion air is supplied directly through an outside wall such as intake louver openings into the dwelling, each opening should give a minimum free area of one square inch per 15,000 Btu/hour of the total input ratings of all appliances in the enclosed area.

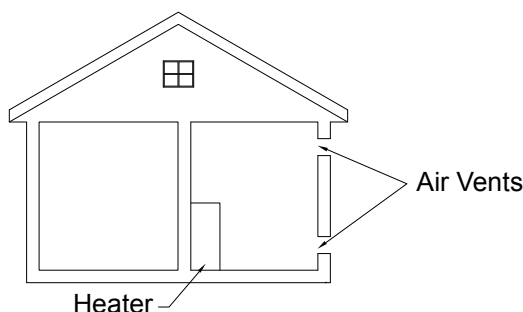

Air supply from inside building:

When combustion air is supplied from inside the building, each opening should give a minimum free area of one square inch per 3,750 Btu/hour of the total input ratings of all appliances in the enclosed area. These openings should never be less than 40 sq.in.

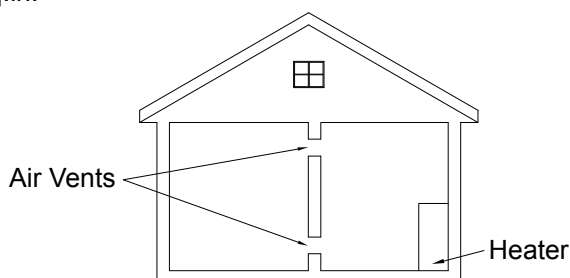

The minimum required inside air volume should be 50 cu.ft per every 3,750 Btu/hour.

Model #	Water Heater Capacity	Minimum Required Air Volume
GU100	Max. 100,000 Btu/hour	1333 cu.ft

Outdoor Installation

Clearances

From top of water heater	24 inches	From back of unit	0.6 inch
From front of unit	24 inches	From left side of unit (gas piping side)	6 inches
From side wall flue or vent connector in any direction	6 inches	From right side of unit	2 inches

If this unit is installed under an overhang, there must be a 24" clearance from the top of the unit to the overhang, and the surrounding area must be open in front and on the sides of the unit.

Exhaust Ventilation

- For outdoor installation, do not remove the vent cap from the top of the appliance. Locate the water heater in an open, unroofed area, and maintain the above minimum clearances from combustible materials.



WARNING



Do not have the flue terminal pointing toward an opening into the building. Do not locate your heater in a pit or any location where gas and water can accumulate.

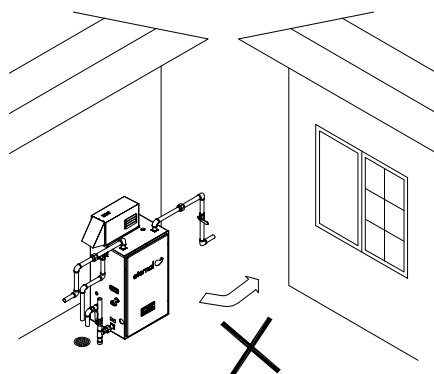

WARNING



Do not install the water heater where water, debris or flammable vapors may get into the flue terminal. This may cause damage to the water heater.

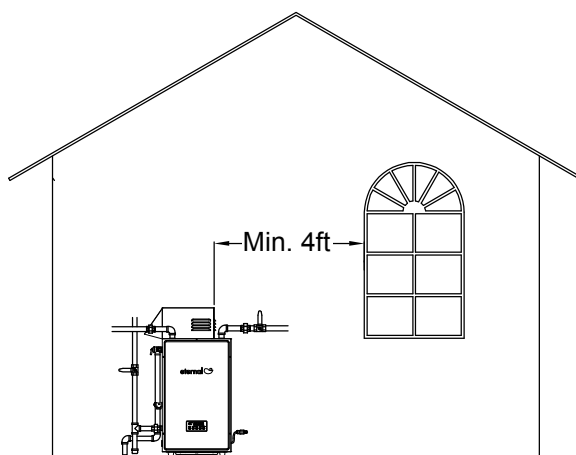

WARNING - high elevation installations



- Natural gas in high altitude might contain less heating value than typical 1100 BTU/ cuft and therefore can cause improper air / gas mix leading to improper combustion. For natural gas installations in altitudes above 3,000 feet, be sure to apply the intake orifice (P/N 152140230) provided by manufacturer in the accessory box.
- Dipswitch setting for high altitude is different to sea level installation, Please call 1-866-946-1096 to speak to a service technician for proper configuration.

Mobile Home Installation



WARNING



Read and Review this entire Manual with special emphasis on the combustion and ventilation for your safety. If you do not follow these instructions exactly, a fire or explosion could result causing property damage, personal injury or loss of life.

Eternal water heater must be used as sealed combustion type (Direct Vent) where all the combustion air is supplied from the outdoors through the air intake and all combusted gas by products are vented directly to the outside by means of the vent termination.

MOBILE HOME(Manufactured Home).

This appliance must be installed in accordance with the Manufactured Home Construction And Safety Standard,(Title 24, CFR; Part 3280). In addition, install in accordance with the following instructions, the instructions supplied with the venting termination, local codes, utility company requirements for the installation of water heaters in manufactured homes (mobile homes). In the absence of such a standard, the water heater should be installed in accordance with the latest edition of the National Fuel Gas Code, ANSI Z223.1/NFPA 54 and ANSI A119.5/NFPA 501D.

LOCATION for MOBILE HOME(Manufactured Home).

Per code, water heaters must be installed with a sealed combustion design so as to separate the water heater's combustion and venting system from the interior atmosphere of the manufactured home. In accordance with code - water heaters must be direct vented. Please refer to direct venting instructions and diagrams on page 19.

Placement of Water Heater: Locate the water heater as desired, make certain the minimum clearances are maintained. For indoor and outdoor installation follow entire Eternal operation manual, please see section above on manufactured home and recreational park trailer outdoor installation.

When installing in a garage, the heater's ignition source should be elevated no less the 457mm (18") from the floor unless the flooring is listed as being resistant to the ignition of flammable vapors.

Operations Manual should be attached to the unit after installation.

EC Adapter Installation

□ How to install the EC Adapter

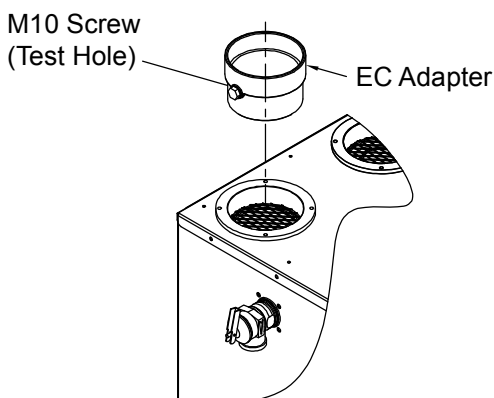

□ How to test exhaust combustion air

1. Loosen M10 screw.
2. Insert the combustion probe.
3. After test, retighten M10 screw on the EC Adapter and make sure no leak.

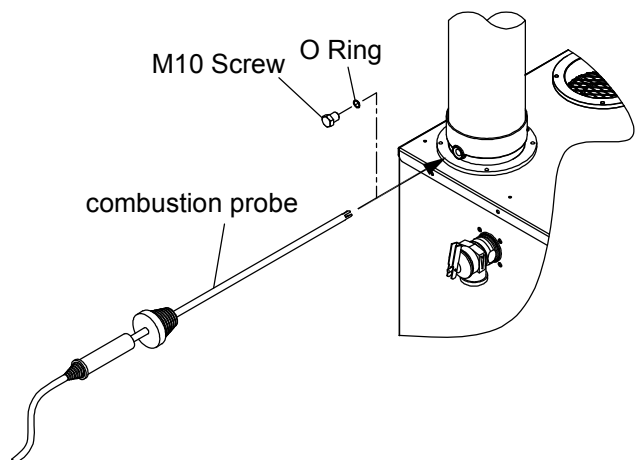

Note: It is not necessary to glue the EC Adaptor into the top of the unit, but when installing PVC vent pipe into EC Adaptor it is recommended you glue the PVC into the EC Adaptor.

Note: For outdoor installation, please install EC Adapter to check gas setting prior to install outdoor venting cap or PVC vent pipe.

Wall Mounting



WARNING



- The water heater must be properly supported; if the wall is not strong enough, be sure to reinforce the wall. The unit must be mounted on a vertical wall and level to the ground.
- Wall mount may caused noises and vibration to magnify through the wall; carefully select where to mount the unit is important. In some cases, floor mount should be considered.

Mounting Steps

1. Install mounting brackets with 6 screws on top and bottom back of the unit.

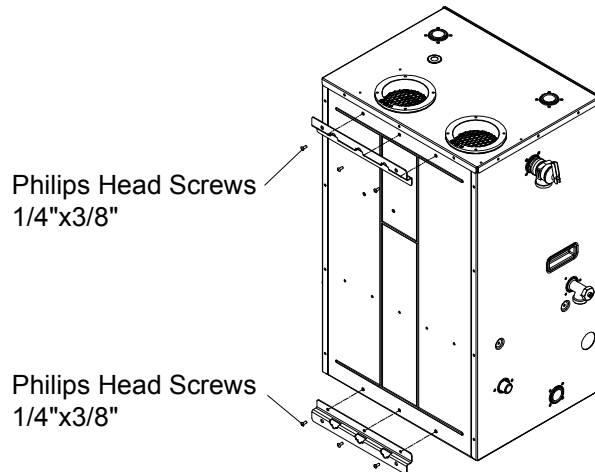

2. Select a location on the wall to mount the unit. The included wall bracket has been pre-drilled for easy installation on standard stud walls. If the framing is not standard or installing on an uneven surface, fasten 3/4" plywood to the stud wall and then attach the wall bracket.

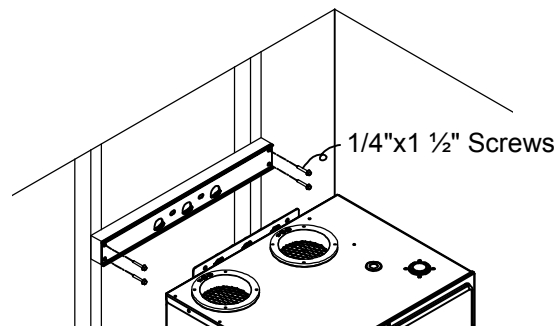

3. Hang the unit on the mounted wall bracket and secure bottom of the unit to the wall with included wall anchors and wall screws.

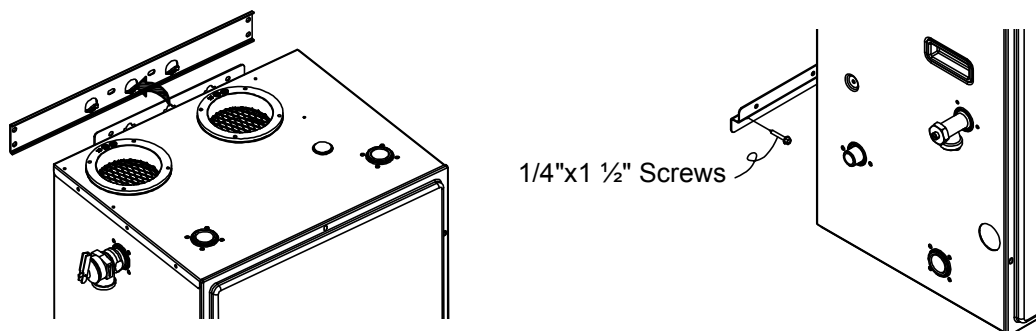

Floor Mounting

Standing Installation

- GU100 can be installed standing on combustible floor surface, or on a water heater stand.
- Be sure to use a suitable draining pan under the unit if leakage of the tank or connections will result in damage to the area adjacent to the appliance.

Floor Standing

Place unit directly on an even surface. Factory installed rubber feet can be adjusted if the surface is slightly uneven.

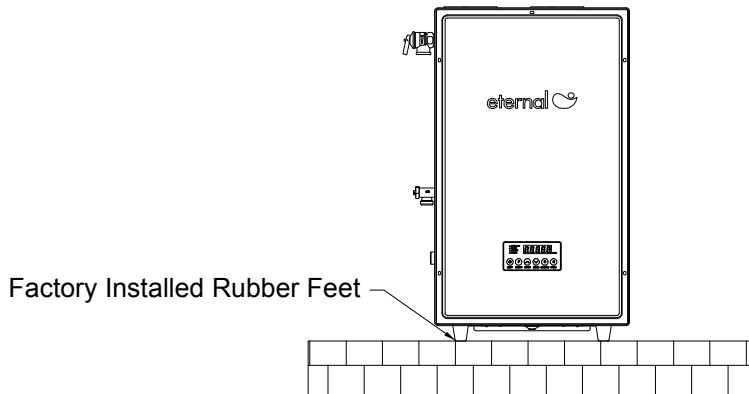

Earthquake Proofing

Secure the unit to the wall with included wall mount bracket. Be sure to install the wall mount bracket to the wall studs.

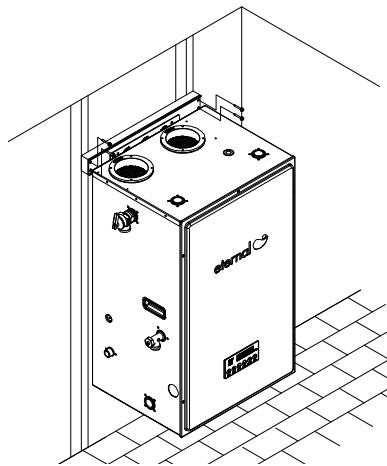

CAUTION



If local codes require the water heater to be raised 18" above floor, installing GU100 on the optional Eternal Water Heater Stand (P/N 314080136) will satisfy code. In conjunction, the unit on stand raises the FVIR compliant igniter and burner at least 18" off the floor. Alternatively, raising the unit at least 6" off the floor will also satisfy code.

Venting Intake & Exhaust Material



WARNING



This water heater must be properly vented for removal of exhaust gases to the outside of the home. Correct installation of the vent pipe system is mandatory for the safe and efficient operation of this water heater and is an important factor in the life of the unit.

Vent Pipe Material

The appliance must be vented separately from all other appliances. The following type of non-metallic vent can be used:

- PVC (schedule 40, ASTM-D1785)
 - CPVC (schedule 40, ASTM-D2846)
 - PVC-DWV (ANSI/ASTM-D2665)
 - ABS (schedule 40, ASTM-D2661)
 - Polypropylene Pipe Single wall & Components (ULC-S636, UL-1738)
- * Note : Do not use cellular foam core pipe.

Cementing PVC, ABS or CPVC PIPE and FITTING

All primers, cleaners and cements must meet all local codes and applicable standards of the American Society for Testing Materials (ASTM).



NOTICE-VENTING GUIDELINES



The following guidelines should be followed when installing the exhaust outlet piping:

- Venting should be as direct as possible with a minimum number of pipe fittings.
- Venting diameter must not be reduced unless specially noted in the installation instructions.
- Support all horizontal pipe runs every 3½ feet according to local codes.
- Vents running through unconditioned spaces where below freezing temperatures are expected should be properly insulated to prevent freezing. For horizontal runs, wrap the vent pipe with self-regulating 3 or 5 watt heat tape. The heat tape must be U.L. listed and installed per manufacturer's instructions.
- Do not connect this venting system with an existing vent or chimney.
- Do not connect common vent with the vent pipe of any other water heater or appliance.
- Do not use low profile wall termination.
- Do not use non return valve.
- Do not use bushing as reducer.



WARNING



For installations in Canada, field supplied plastic vent piping must comply with CAN/CGA-B149.1 (latest edition) and be certified to the Standard For Type BH Gas Venting Systems, ULC S636 Components of this listed system shall not be interchanged with other vent systems or unlisted pipe/fittings. All plastic components and specified primers and glues of the certified vent system must be from a single system manufacturer and not intermixed with other system manufacturer's vent system parts.

The supplied vent connectors are certified as part of the water heater.



WARNING



If the Eternal combustion air inlet is located in an area likely to cause or contain contamination, the combustion air must be repiped and terminated at another location. Contaminated combustion air will damage the unit and its burner system, resulting in possible severe personal injury, death or substantial property damage.

Venting Specification

Direct Vent

- GU100 is factory configured as a sealed combustion unit with dedicated intake and exhaust connections.
- When installed as a Direct Vent appliance, all combustion air is drawn directly from outside of the home.
- Direct Vent configuration is suitable for indoor only.
- Recommended for facilities with difficulty accessing combustion air.

Power Vent

- When installed outdoors, outdoor venting cap should be used.
- Can be installed indoors, if combustion air supply is sufficient.
- Is not sealed combustion if intake is not used to bring air directly from outside.

! WARNING !

Insufficient air supply used with Power Vent appliance may cause the building to experience negative pressure inside. Negative pressure is not allowable by most building codes and can cause back drafting of cold air from outside through the unit potentially freezing the heat exchanger.

How To Configure Unit For Power-Vent

To configure the unit for power vent, insert a 6" section of 3" pvc and terminate the intake with a 90° elbow. Be sure to insert the included mesh screen into the intake hole before the PVC pipe.

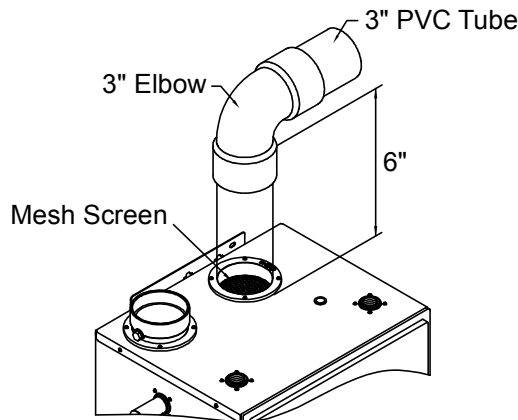

Maximum Allowable Vent and Combustion Air Piping Length

3 inch Piping	
Feet	Max # of 90° elbows
100	6

- Reduce the maximum allowable length for each elbow used as follows:
 - 45 degree elbow : Deduct 3 feet
 - 90 degree elbow : Deduct 5 feet
- Allow minimum length of 6" vent run vertically off the water heater is required before using any elbow.
- Some termination is considered as a type of elbow, correct deduction should be applied. Such as, a turn down 90° or an open T termination is considered 1x90° elbow and a candy cane termination is considered as 2x90° elbow.
- The intake vent length can be of equal length or less; there is no balancing requirement between intake and exhaust.
- To avoid accumulation of condensate water in exhaust vent run, it recommended to position the start of the horizontal section lower then slope upwards with no less than 1/4 per foot towards the venting termination to allow condensation flow back into the unit.

Vertical Termination

Below diagrams are examples of vertical terminations.

Through roof (Direct Vent)

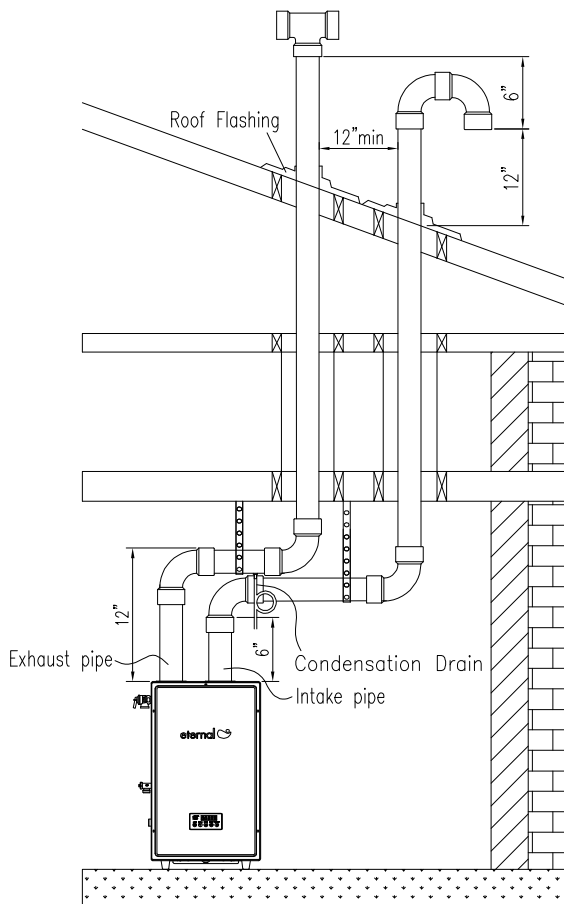

Through roof (Concentric Vent)

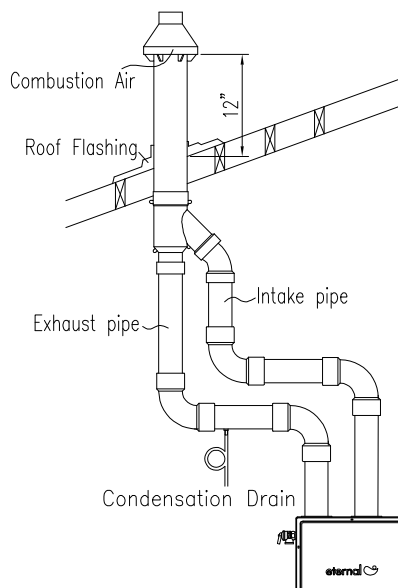

Through roof (Power Vent)

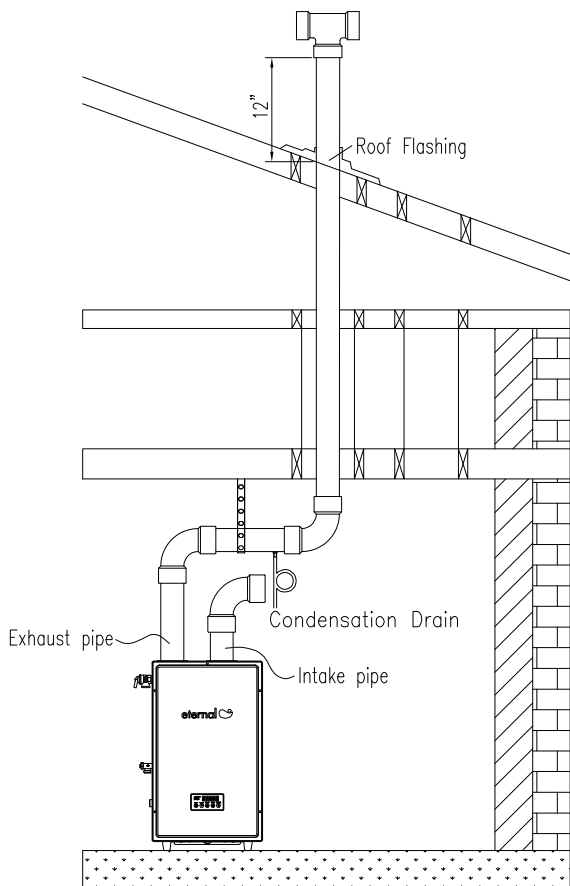

!
!
WARNING

The Grand Hall approved concentric kit is a unique pipe-in-pipe venting system designed for termination. Do not try to replicate or make your own. For more information, please refer to **Concentric Vent Kit** section in the Operation manual.

An open tee is optional but recommended to use as a termination to alleviate and prevent back pressure in the venting system.

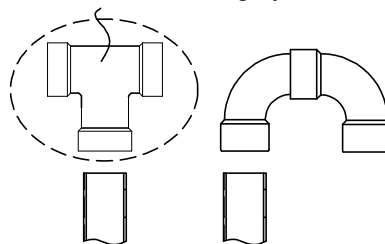

!
!
WARNING

- Minimum twelve (12) inches above anticipated snow level.
- It cannot be connected to existing vent piping or chimney.
- The total vertical and horizontal runs cannot exceed the maximum length with a maximum number of 90 degree elbows as specified in the table on page 18.
- Eternal can be vented straight up and a horizontal section is not required for vertical terminations.

Horizontal Termination

Below diagrams are examples of vertical terminations.

□ Side Wall (Direct Vent)

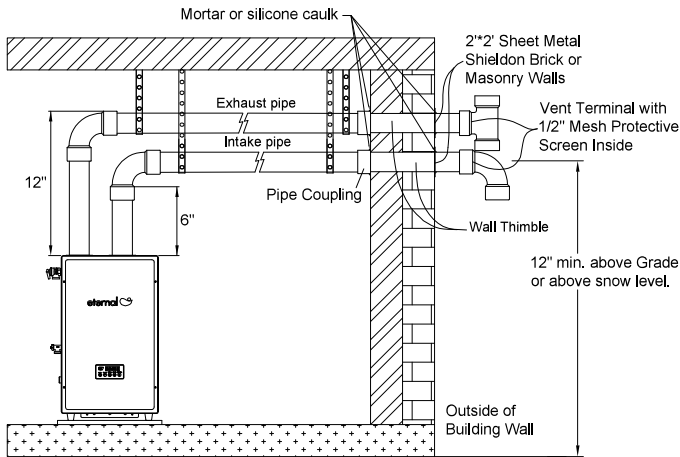

□ Side Wall (Power Vent)

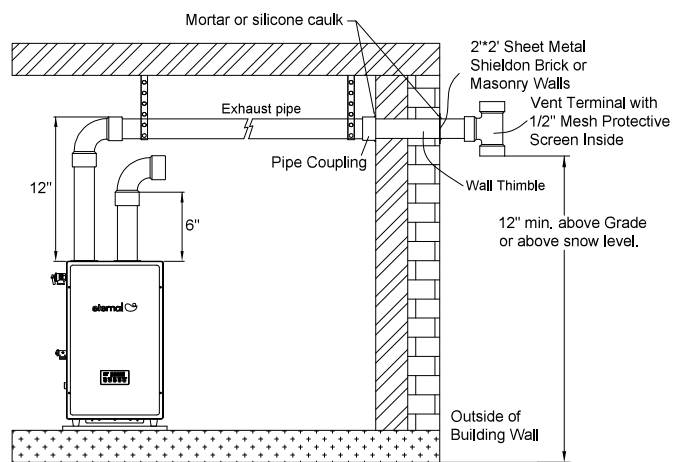

Exterior View

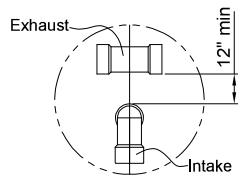

WARNING

The Grand Hall approved concentric kit is a unique pipe-in-pipe venting system designed for termination. Do not try to replicate or make your own. For more information, please refer to **Concentric Vent Kit** section in the Operation manual.

□ Side Wall (Concentric Vent)

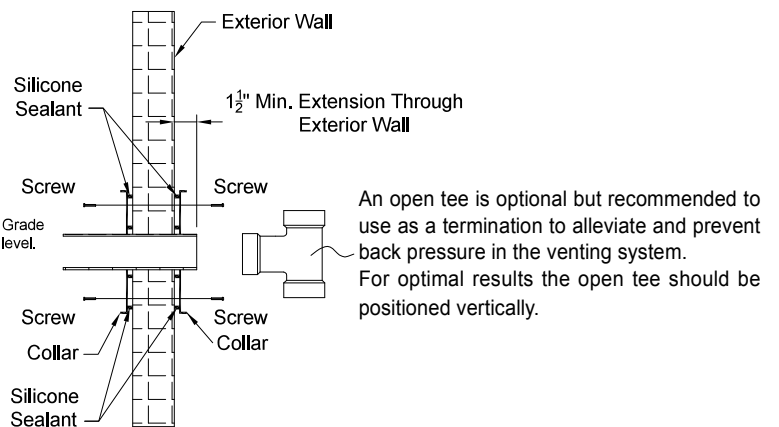
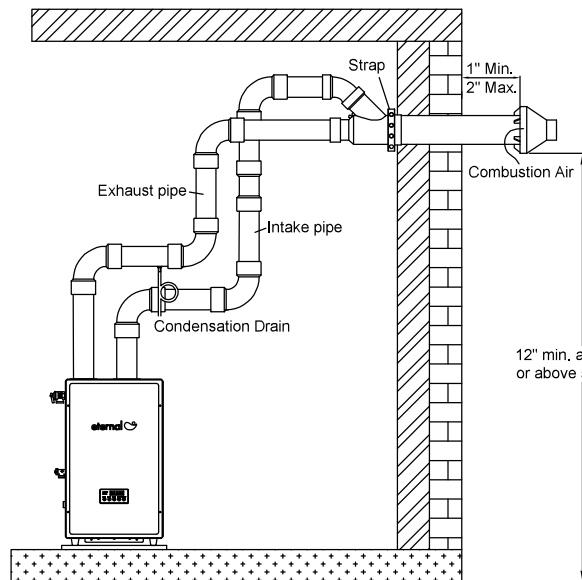

WARNING

- Once the vent terminal location has been determined, make a hole through the exterior wall to accommodate the vent pipe. Vent pipe must only exit exterior wall horizontally.
- Place the 1/2" metal mesh screen inside the terminal fitting and connect it as shown to the vent pipe on the exterior of the building.
- Seal any opening around the vent pipe or fittings with mortar or silicone caulk "as shown" above.
- Complete the rest of the vent pipe installation to the water heater's vent connector fitting on the blower outlet. If necessary support horizontal run as previously mentioned.

Clearance Requirements from Vent Terminations to Building Openings

All clearance requirements are in accordance with ANSI Z21.10.3 and the National Fuel Gas Code, ANSI Z223.1 and in Canada, in accordance with NSCNPIC.

□ Vent Clearances When Heater is Installed Indoors

Maintain the following clearances to any opening in any building:

- 4' below, 4' horizontally from, or 1' above any door, operable window, or gravity air inlet into any building.
- 3' above any forced air inlet within 10'.

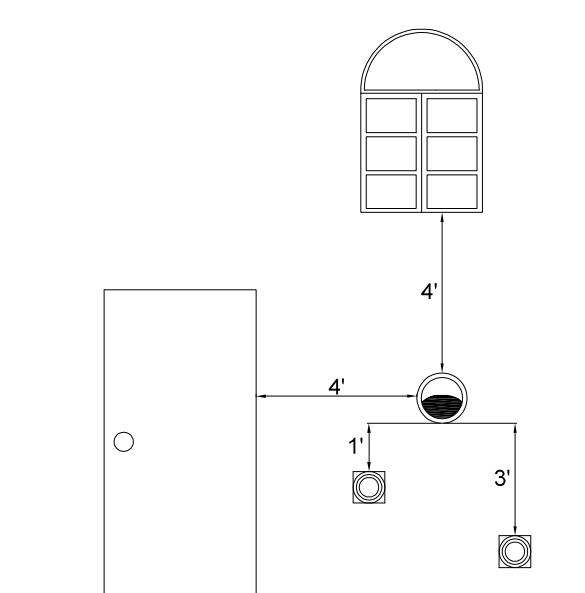

□ Vent Clearances When Heater is Installed Outdoors With a Vent Cap

Maintain the following clearances to any opening in any building:

- From the unit: 4' below, 4' horizontally from, or 1' above any door, operable window, or gravity air inlet into any building.
- 3' above any forced air inlet within 10'.
- For outdoor installation, we recommend using the outdoor venting cap for rain protection.

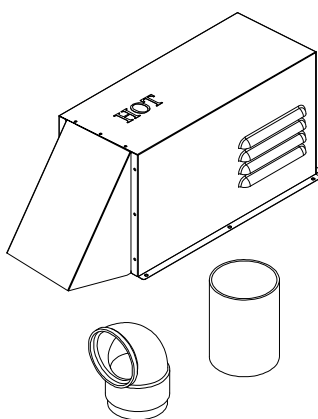

Outdoor Venting Cap

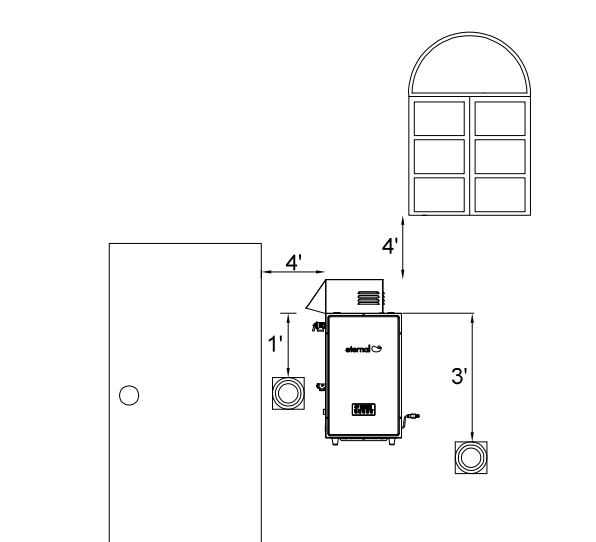

WARNING



For Installations in Canada, clearances are as follows: To windows, doors, & gravity air inlets: 36".
To forced air inlets: 6'. These clearance requirements hold true for all of the above situations: Indoor, Outdoor w/vent cap.

Concentric Vent Kit



WARNING



Failure to comply with the following warning could result in product damage or improper operation, personal injury, death, substantial property and/or warranty will be voided.

- Do not use concentric kit which are not approved by Grand Hall.
- Do not operate the appliance with the rain cap removed or recirculation of combustion byproducts may occur. Water may also collect inside the larger combustion air pipe and flow to the burner enclosure.
- Do not make alternation to the approved Grand Hall concentric kit, such as length, downsize or any other part.
- Do not allow insulation or other materials to accumulate inside the pipe assembly when installing through the hole. Ensure termination height is above the roof surface or anticipated snow level (12 inches in USA or 18 inches in Canada).
- Do not use field-supplied couplings to extend pipes. Airflow restriction will occur and may caused intermittent operation.

* Approved Grand Hall Concentric Kit

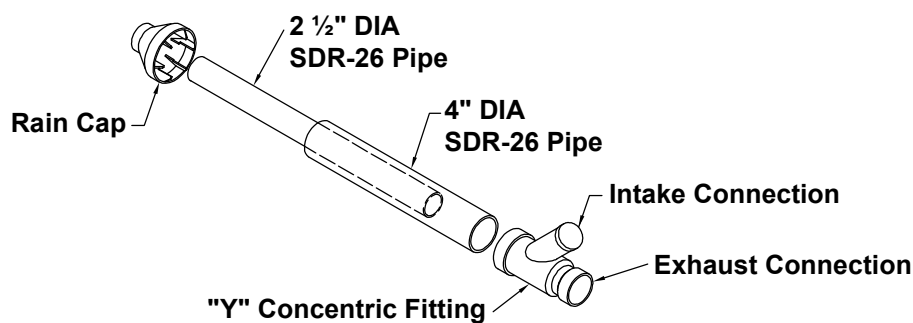

Note! When installing Horizontally, It's recommended to position the intake connection of the concentric kit to face upward to prevent rainfall/water accumulation flow through the intake pipe into the unit.



WARNING



When using the approved concentric kit, **3" pipe is required for the entire intake and exhaust vent run.** The maximum intake or exhaust vent run cannot exceed more than 50ft on each side. Be sure to subtract 5' off your total vent run per 90° elbow or subtract 2.5' off total vent run per 45° elbow that will be used. Only up to 4x90° elbow or max 8x45° elbow is allowed for either side of intake or exhaust.



NOTICE



Requirements for Installation in Canada

- Installations must be made with a vent pipe system certified to ULC-S636.
- The first three (3) feet of plastic vent pipe from the appliance flue outlet must be readily accessible for visual inspection.
- The components of the certified vent system must not be interchanged with other vent systems or unlisted pipe/ fittings. The inner vent tube must be replaced with field supplied certified vent material to comply with this requirement.

Outdoor Vent Kit

Installation Instructions:

1. Remove included 6 screws on the unit.
2. Install the 3" DIA PVC Pipe.
3. Install the Outdoor Vent Kit on the unit with included 6 screws.

The length of 5.75" PVC pipe included with the Vent Cap must be installed on the intake side.

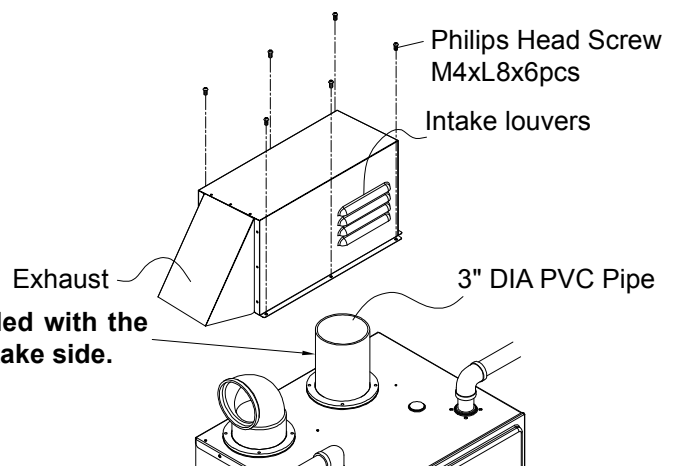

Vent Pipe Installation & Terminator Position

	Description	US Installations		Canadian Installations
		Other than Direct Vent	Direct Vent	
A	Clearance above grade, veranda, porch, deck, or balcony	1 foot	1 foot	1 foot
B	Clearance to window or door that may be opened	4 feet below or to side of opening; 1 foot above opening	1 foot	3 feet
C	Clearance to permanently closed window	*	*	*
D	Vertical clearance to ventilated soffit located above the terminal within a horizontal distance of 2 feet from the center line of the terminal	*	*	*
E	Clearance to unventilated soffit	*	*	*
F	Clearance to outside corner	*	*	*
G	Clearance to inside corner	*	*	*
H	Clearance to each side of center line extended above meter/regulator assembly	*	*	3 feet within a height 15 feet above the meter/regulator assembly
I	Clearance to service regulator vent outlet	*	*	3 feet
J	Clearance to non-mechanical air supply inlet to the building or the combustion air inlet to any other appliance	4 feet below or to side of opening; 1 foot above opening	1 foot	3 feet
K	Clearance to a mechanical air supply inlet	3 feet above if within 10 feet horizontal	3 foot	6 feet
L	Clearance above paved sidewalk or a paved driveway located on public property	7 feet	*	7 feet
M	Clearance under veranda, porch, deck, or balcony	*	*	1 foot

*For clearances not specified in ANSI Z223.1 / NFPA 54 or CAN/CSA-B 149.1, please use clearances in accordance with local installation codes and the requirement of the gas supplier.

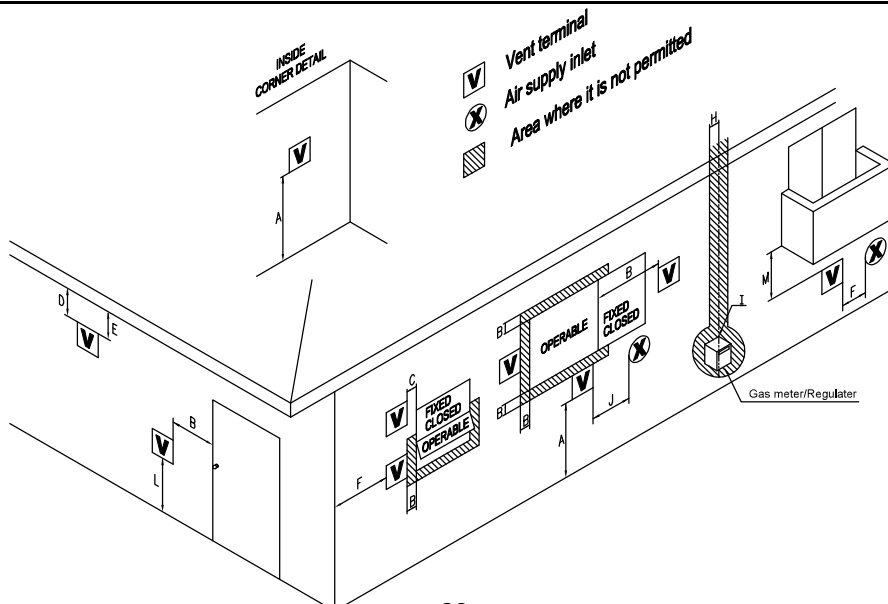

Gas Supply Piping



NOTICE



- This unit needs a manual gas control valve (shut-off valve) that must be connected to the unit before the gas line.
- Check the gas inlet pressure and the type of gas matching the rating plate located on your water heater. Also check to make sure your gas meter is capable of supplying sufficient BTU load to all appliances. Insufficient gas pressure and volume will cause your water heater to be deficient in performance and may not work properly.
- When connections are completed, check for gas leaks by applying soapy water to all gas fittings and connections. Presence of soap bubbles foaming is a sign of gas leaks.
- This appliance and its individual shut-off valve must be isolated from the gas supply piping system by unplugging the unit and turning off the main gas valve during any pressure testing of the gas supply piping system at test pressures equal to or less than 1/2 PSI.

Gas Piping System Codes

Size gas piping system correctly following ANSI Z223.1/NFPA 54, or by local code.

- When measuring the inlet supply pressure, the water heater and all other gas appliances sharing the gas supply line must be firing at maximum capacity.
- Maximum gas pressure must not exceed listed value.
- Low gas pressure could be caused by an undersized gas pipe; this will cause the water heater's performance to diminish and it would not be able to reach maximum performance.
- These tables are for reference only. Please consult the gas pipe manufacturer for actual pipe capacity.

NATURAL GAS SUPPLY PIPING

Pipe size	Cubic Feet of Natural Gas													
	Length	10'	20'	30'	40'	50'	60'	70'	80'	90'	100'	125'	150'	200'
1/2"		172	118	95	81	72	65	60	56	52	50	44	40	34
3/4"		360	247	199	170	151	137	126	117	110	104	92	83	71
1"		678	466	374	320	284	257	237	220	207	195	173	157	134
1 1/4"		1390	967	768	657	583	528	486	452	424	400	355	322	275
1 1/2"		2090	1430	1150	985	873	791	728	677	635	600	532	482	412
2"		4020	2760	2220	1900	1680	1520	1400	1300	1220	1160	1020	928	794

Based on 0.60 specific gravity for natural gas at 0.5" W.C. pressure drop. DOE standard is 1000 BTU per cubic ft. of natural gas

NATURAL GAS SUPPLY PIPING

Pipe size	Cubic Feet of Natural Gas													
	Length	10'	20'	30'	40'	50'	60'	70'	80'	90'	100'	125'	150'	200'
1/2"		454	312	250	214	190	172	158	147	138	131	116	105	90
3/4"		949	552	524	448	397	360	331	308	280	273	242	219	188
1"		1787	1228	986	844	748	678	624	580	544	514	456	413	353
1 1/4"		3669	2522	2025	1733	1536	1392	1280	1191	1118	1056	936	848	726
1 1/2"		5497	3778	3034	2597	2302	2085	1919	1785	1675	1582	1402	1270	1087
2"		10588	7277	5844	5001	4433	4016	3695	3437	3225	3046	2700	2446	2094

Based on 0.60 specific gravity for natural gas at 3.0" W.C. pressure drop; **8.0" W.C. or greater supply pressure**. DOE standard is 1000 BTU per cubic ft. of natural gas

PROPANE GAS SUPPLY PIPING

Pipe size	KBTU of Propane Gas												
	Length	10'	20'	30'	40'	50'	60'	80'	100'	125'	150'	175'	200'
1/2"		291	200	160	137	122	110	101	94	89	84	74	67
3/4"		608	418	336	287	255	231	212	197	185	175	155	140
1"		1150	787	632	541	480	434	400	372	349	330	292	265
1 1/4"		2350	1620	1300	1110	985	892	821	763	716	677	600	543
1 1/2"		3520	2420	1940	1660	1480	1340	1230	1140	1070	1010	899	814
2"		6790	4660	3750	3210	2840	2570	2370	2200	2070	1950	1730	1570

Based on 1.50 specific gravity for propane gas at 0.5" W.C. pressure drop; 11" W.C. supply pressure

LP Conversion



NOTICE



Contact the local propane gas supplier for recommended sizing of piping, tanks and 100% lockup gas regulator.
□ Adjust the propane supply regulator provided by the gas supplier for 13" w.c. maximum pressure.



NOTICE



LP conversion kit must be ordered from Grand Hall USA. Conversion can only be completed by a qualified professional.

How to convert to LP

1. Remove front panel by loosening 5 screws.

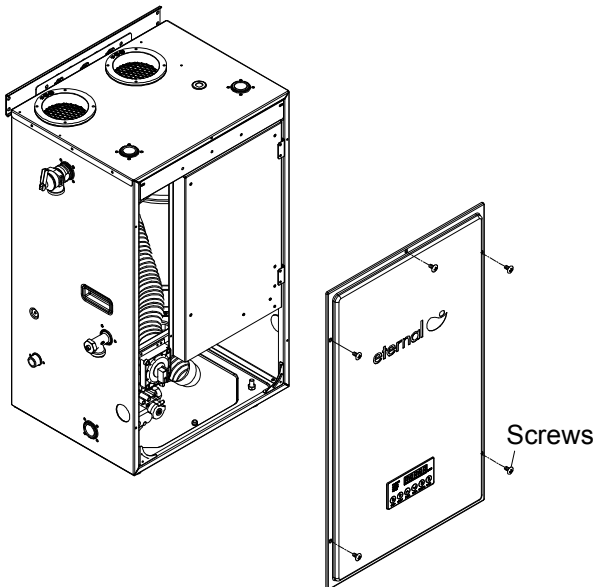

2. Locate the gas valve towards lower left of the unit.

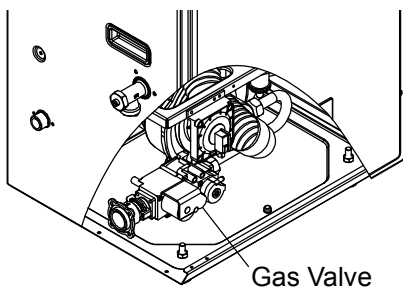

3. Loosen nut connecting gas tube to gas valve.

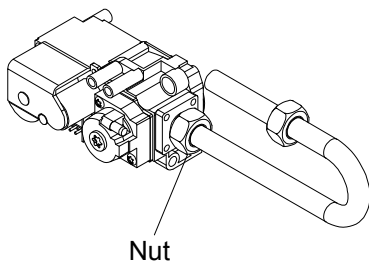

4. Insert LP orifice into the nozzle, retighten gas tube and make sure no gas leak.

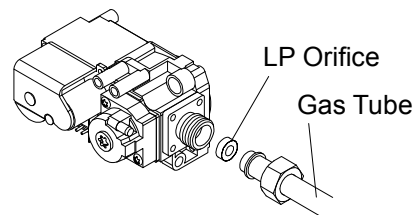

5. Reassemble the front panel and apply the LP label which is in the accessory kit.

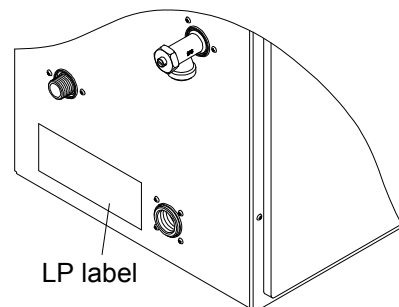

WARNING



Prior to start up, ensure the unit is set to fire propane. Check the rating label for the type of fuel. If there is a conflict or doubt on the setup, remove the gas valve and check for the propane orifice. Failure to ensure proper setup could result in severe personal injury, death or substantial property damage.

Water Supply Connection

WATER SUPPLY CONNECT

- The water fittings on the Eternal water heater are 3/4" NPT. If the installation site has only 1/2" plumbing throughout the building, it is not necessary to up size the water lines to 3/4" when installing a single unit.
- When installing more than one unit to supply higher volumes of hot water in residential applications, the number of Eternal water heaters required and the header pipe sizing needs to be properly sized to meet the total hot water demand.
- All pipes, pipe fittings, valves and other components including solder, must be approved for use in potable water systems.
- The use of unions and material shut off valves on both the cold water inlet and hot water outlet is recommended.
- The use of brass stainless steel or copper unions/nipples is recommended for use with an Eternal water heater.
- Take measures to prevent water pipe from freezing is important. In the event of frozen water pipe, Eternal will not be able to activate freeze protection function due to loss of water pressure and will be susceptible to freeze and cause serious unit damage.
- Do not install eternal water heater with iron or galvanized piping.



WARNING



- Eternal is designed for full flow with low pressure loss. Without flow restriction, if Eternal is overdrawn due to demand exceeding unit(s)'s BTU recovery capacity, outlet temperature will not reach set point. However, full flow without diminished hot water pressure will continue to be delivered. It is important to make sure each job is properly sized to ensure hot water demand can be satisfied.
- Be careful not to reverse the hot water outlet and cold water supply line connections to the water heater. This will cause your water heater to operate dangerously and void warranty. Make sure the hot and cold lines are connected properly.

FILLING THE WATER

- Close the water heater drain valve by turning the knob to the right. The drain valve is on the lower left side of the water heater.
- Open the cold water supply valve to the water heater.
- To ensure complete filling of the tank, allow air to purge by opening the nearest hot water faucet. Allow water to run until a constant flow is obtained.
- Check all new water piping for leaks. Repair as needed.



CAUTION



- Never use this water heater unless it is completely filled with water.
- Be certain there are no loose particles or dirt in the piping. Keep a copper pipe diameter at NPT 3/4 inch diameter to allow full flow. If the hot and cold connections are reversed, the heater will not work properly and could damage the unit. Be sure to connect them correctly.
- If water flow is low, check the filter by removing the draining valve.

DRAINING THE WATER

- Close water supply shut-off valve to the unit first.
- Connect garden hose to the draining valve located on the lower left side of the unit.
- Open the valve by using a flat head screw driver to drain water with the hose.
- After draining the tank, turn the valve body to remove the draining valve from the unit and clean the filter.



CAUTION



Do not open the draining valve without connecting a hose so that water can be diverted to an area where water damage is not a problem. Do not remove the draining valve from the unit without first draining the tank.

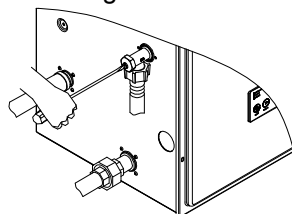

WARNING



The use of galvanized or dielectric unions & piping is prohibited for use with an Eternal water heater. Failure to comply with this warning will void warranty.

Condensate Piping



CAUTION



In order to drain the condensate, installing the condensate T fitting in the accessory kit is required. Do not reduce the size of the fitting or the drain pipe. The condensate T fitting is designed to fit on 1/2" PVC (schedule 40, ASTM-1785) or 3/4" CPVC (SDR11, ASTM-D2846) pipe.

The end of the drain pipe must not be submerged in water or blocked in any way.

Take measures to prevent the condensate drain lines from freezing if required (insulation, heat tape, electric heater, ect.)

- This water heater is a high efficiency, fully condensing appliance which produces condensate during operation. The water heater incorporates a collection, neutralization, and removal system which must be properly drained in order to ensure proper operation of this appliance.
- Please use PVC or CPVC for the drain line.** Do not use steel, black iron, or any other material which can corrode when placed into contact with condensate water.
- Keep the length of the drain pipe as short as possible. Long runs or applications where the nearest drain is above the water heater will require the use of a condensate pump. Size the pump to allow for a maximum condensate discharge of 2 GPH from the water heater.
- Horizontal runs must be sloped 1/4" per foot towards the drain or condensate pump.
- Be sure to check that condensate is freely flowing from the drain piping after the system has been installed. Condensate will begin flowing out of the water heater within 15 minutes after operation has started.



WARNING



To ensure proper disposal of condensate do not install neutralizer vertically.

TYPICAL INSTALLATION

Condensate piping to floor drain

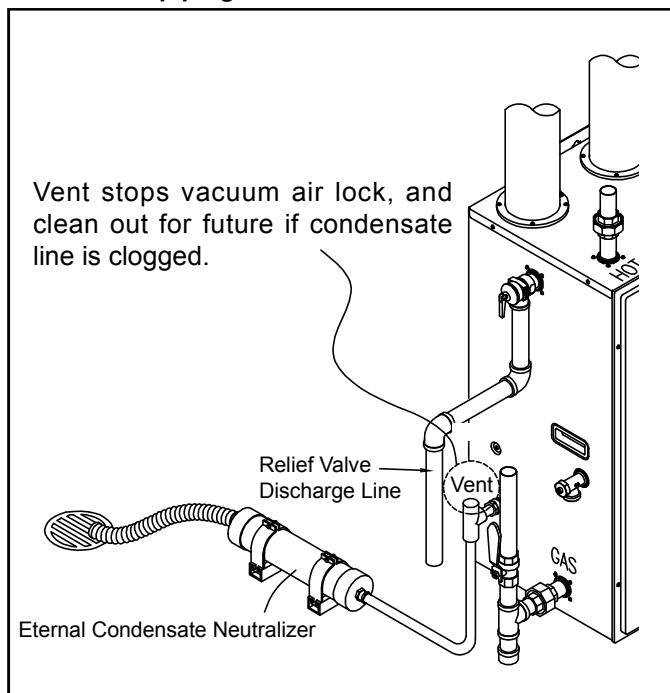

Condensate piping to Condensate pump

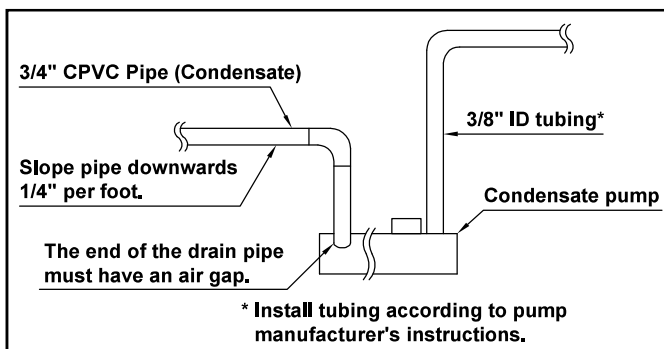
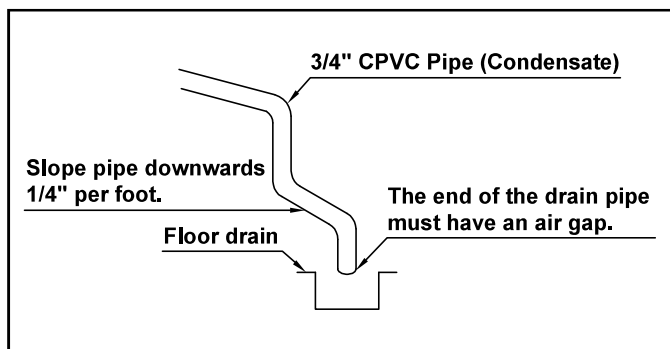
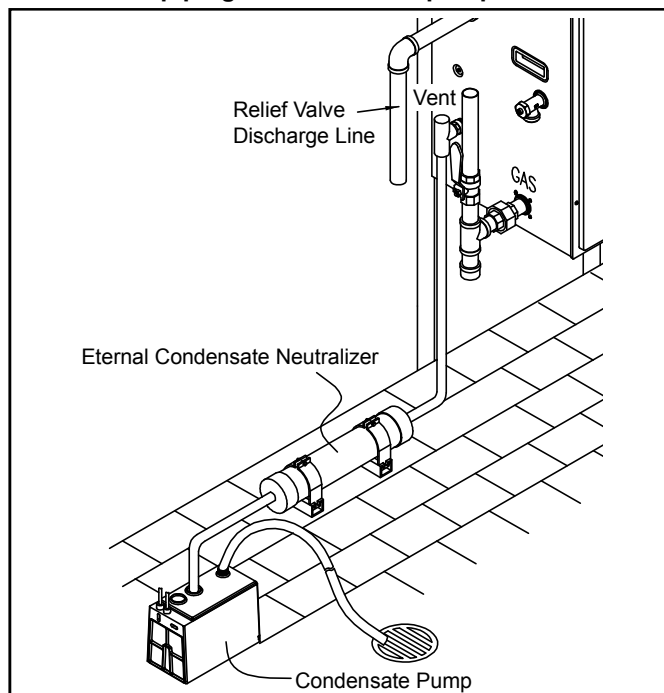

Temperature and Pressure Relief Valve

The following 3/4", maximum 150psi valves are approved by CSA for use with GU100 :
- Cash Acme NCLX-5L



CAUTION



- The temperature-pressure relief valve should be manually opened once a year.
- No one should be in front of or around the outlet of the temperature-pressure relief valve discharge line when in use.
- If after manually opening the valve and it fails to completely reset and continues to release water, immediately close the cold water inlet to the water heater, follow the draining instructions, and replace the temperature-pressure relief valve with a new one. The discharge capacity must be at least 100,000 BTU/HR for GU100.

Troubleshooting Thermal Expansion

If a water heater is installed in a closed water supply system, such as one having a backflow preventer in the cold water supply line then a thermal expansion tank is required, contact the water supplier or local plumbing inspector on how to control this situation.

Electrical Connection

Installation Codes:

Follow the requirements of the local authority having jurisdiction. In the absence of such requirements, follow the latest edition of the National Electrical Code ANSI/NFPA 70.

Grounding and Surges

- Do not plug electrical power to the unit until all plumbing and gas piping is complete and the water heater has been filled with water.
- The use of a surge protector is recommended to protect from power surges.
- Do not connect 220-240V AC to this unit. It will damage the water heater and void the warranty.
- Do not disconnect the power supply when the unit is in normal operation.
- If there is a power failure in cold weather areas, the freeze prevention system in the water heater will not operate and may result in freezing of the unit. In cold weather areas where power failures are common, you must completely drain the unit to prevent damage if the power will be off for any extended period of time. Damage caused by freezing is not covered under warranty.
- A battery back-up may be used to supply hot water during periods of power outages. We recommend a computer-grade UPS (uninterruptable power supply) with at least a 600VA rating for extended coverage.



WARNING



- The water heater must be electrically grounded.
- Do not rely on the gas or water piping to ground the metal parts of the water heater, because plastic pipe may isolate the water heater electrically. Service and maintenance personnel who work on or around the water heater may be standing on wet floors, and could be electrocuted by an un-grounded water heater.

The water heater requires an electrical power supply of 120 VAC/60Hz, and it must be properly grounded to function.

- A means for switching off the 120 VAC power supply must be provided.
- Wire the heater exactly as shown in the wiring diagram.
- Check all new water piping for leaks. Repair as needed.



CAUTION



Label all wires prior to disconnection when servicing controls. Wiring error can cause improper and dangerous operation. Verify proper operation after servicing.

Please refer to the Wiring Diagram. Note: There is a copy located on the inside of the front panel of the appliance.

Wiring Optional Remote Controller(s)

- Max 100ft Run.
- AWG #18 Wire. (wiring is not supplied in unit.)
- Parallel or Serial connection are allowed.

Do not make short circuit by contacting the contacts between two wires during installation.



WARNING



All units come with a factory installed 3-pronged power (grounded) plug. It is required to run a dedicated electrical line to the water heater to prevent electrical interference.

Optional Remote Controller Installation

Pre-Installation Preparation

1. Turn off the unit and unplug power cord from wall socket.
2. Remove front panel by loosening 5 screws.
3. Open one of the pre-cut holes on either side panels of the unit and insert the hole plug.

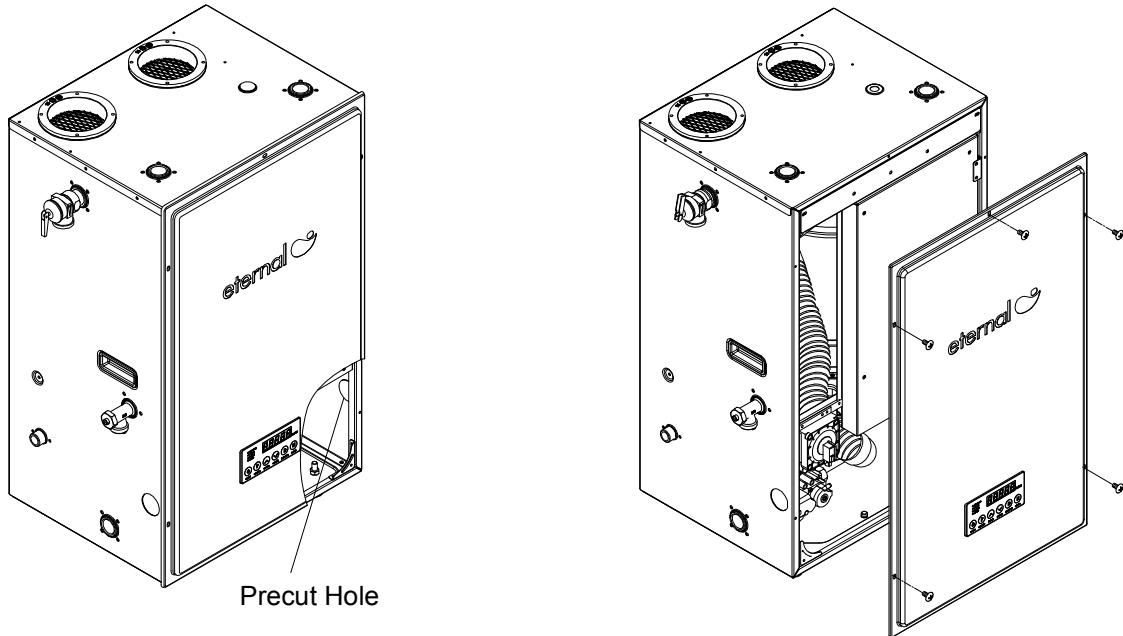

Wiring Instructions

1. Open the main controller PCB cover by removing 1 screw.
2. Run wire from the PCB to where the remote display is to be mounted through the hole plug.
3. Attach wiring to the PCB by loosening 2 screws on the main controller.

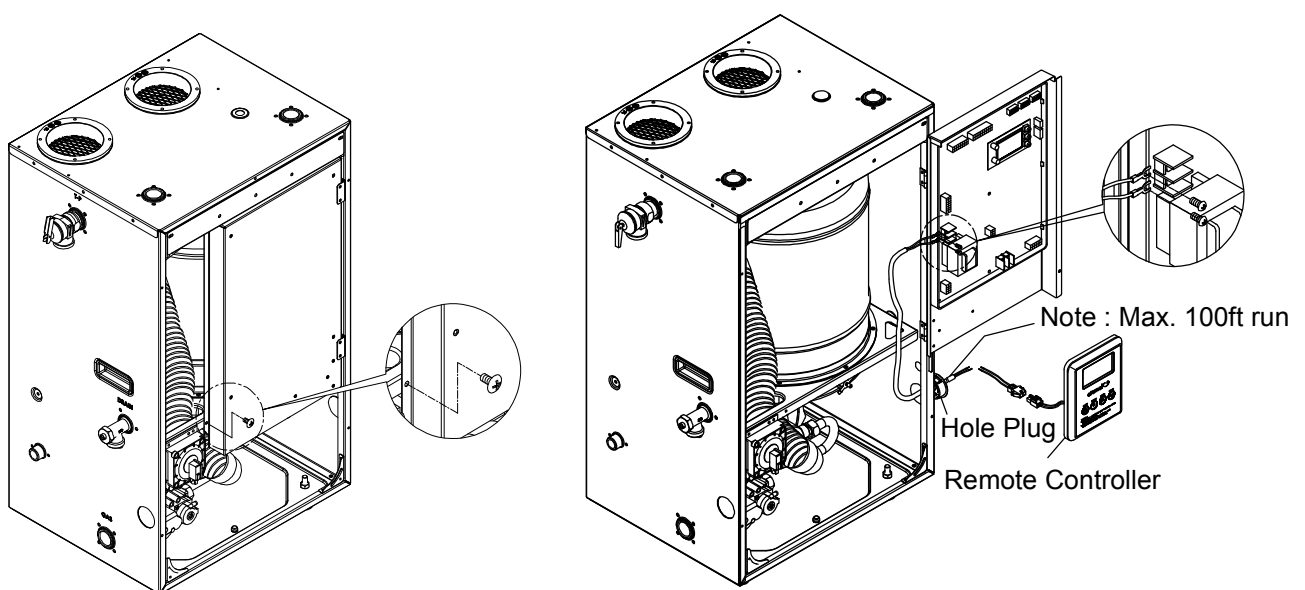

Optional Remote Controller Installation

Configuring Multiple Remote Controllers

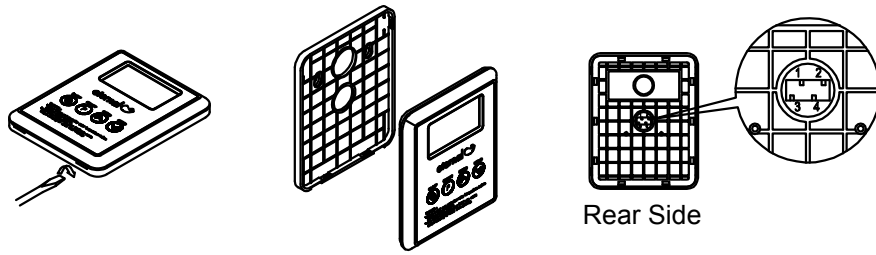

Remote Controller Selection Switch Setting Layout

	Kitchen	1 : Left	2 : Left
		3 : N/A	4 : N/A
	Bathroom 1	1 : Right	2 : Left
		3 : Left	4 : N/A
	Bathroom 2	1 : Right	2 : Left
		3 : Right	4 : N/A

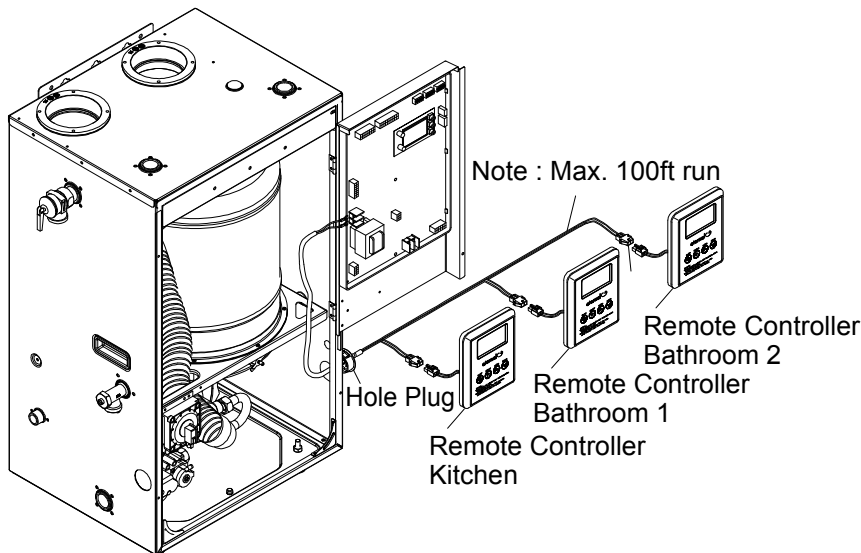

Remote Display Mounting Instructions

1. Decide on the appropriate mounting location for the Remote Controller; consider higher positions so that the controller is out of reach for children.
2. Using a flat head screw driver, or a penny, wedge the Remote Controller open to reveal mounting holes under the cover.
3. Using the template, mark two 1/4" holes in the dry wall. Be sure that the holes are level.
4. Drill two 1/4" holes on the dry wall and insert Wall Anchors.
5. Connect wiring to the back of the remote display by loosening 2 screws.
6. Secure the Remote controller to the Wall Anchors using the included Mounting Screw 2 pcs and replace the cover to hide the mounting hardware.

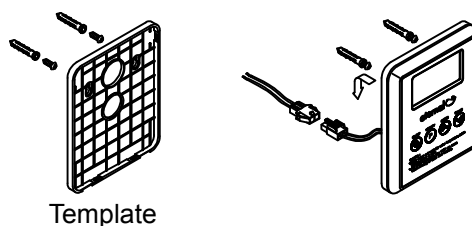

Recirculation System with an Eternal Water Heater

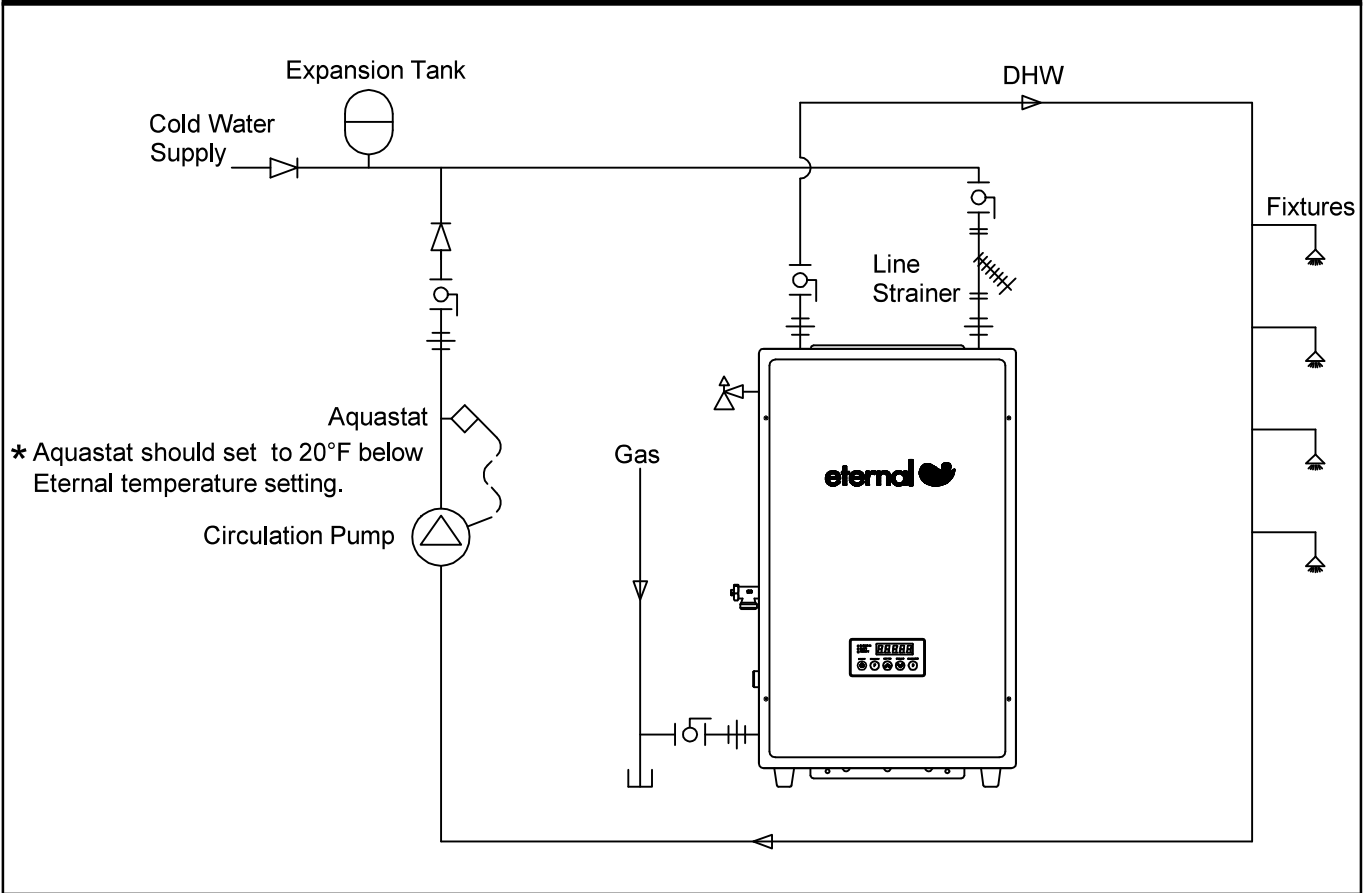

These diagrams are for reference as basic guides. Each installation should be engineered properly and compliant to Local and State Codes.

	WARNING	
Pump control such as timer and / or aquastat must be used in recirculation application or short cycle may occur and cause premature failure. Fail to comply with this warning will void warranty.		

Operating Instructions

Before Starting The System

- This water heater does not have a pilot. It is equipped with an ignition device which automatically lights the burner. Do not try to light the burner manually.
- Before operating, make sure that a gas leak is not evident by smelling the area around the unit. Be sure to smell next to the floor because gas is heavier than air and will settle on the floor.
- Use only your hand to turn the manual gas valve knob. Never use tools. If the knob will not turn by hand, do not try to repair it, call a qualified service technician. Force or attempted repair could result in a fire or explosion due to the gas leakage.
- Do not use this water heater if any part has been under water. Immediately call a qualified service technician to inspect the water heater and to replace any damaged parts.



WARNING



WHAT TO DO IF YOU SMELL GAS

- Do not try to light any appliance.
- Do not touch any electrical switch; Do not use any phone in your building.
- Immediately call your gas supplier from a neighbor's phone. Follow the gas supplier's instructions.
- If you cannot reach your gas supplier, call the fire department.

STARTING UP

- Once the unit has been properly installed, check the gas and water connections for leaks.
- Check for proper ventilation and combustible air supply to the water heater. Purge the gas and water lines to remove debris; then follow these steps to turn on your unit.
 1. Close the manual gas shut-off valve located on the gas line.
 2. Fully open the manual water shut-off valve on the water supply line.
 3. To ensure complete filling of the heat exchanger tank, allow air to exit by opening the nearest hot water faucet. Allow water to run until a constant flow is obtained. This will let air out of the water heater and piping.
 4. Open a hot water tap to check that water will flow to that tap. Then close the hot water tap.
 5. Fully open the manual shut-off gas valve.
 6. Plug in the 120 VAC/60Hz power supply to the water heater and turn on the unit.



CAUTION



- Never use this hot water heater unless it is completely filled with water.**
The tank must be filled with water. Water must flow from the hot water faucet before turning "ON" gas to the water heater.

NORMAL OPERATION

To turn on your water heater

1. Open a hot water tap.
2. Burner will ignite; the indicator will light on front controller.
3. Mix cold water to get the desired water temperature at tap.
4. Maximum temperature of hot outlet can be set by controller on the front of the unit.

To turn off your water heater

1. Close the hot water tap and the water heater's burner will turn off automatically.

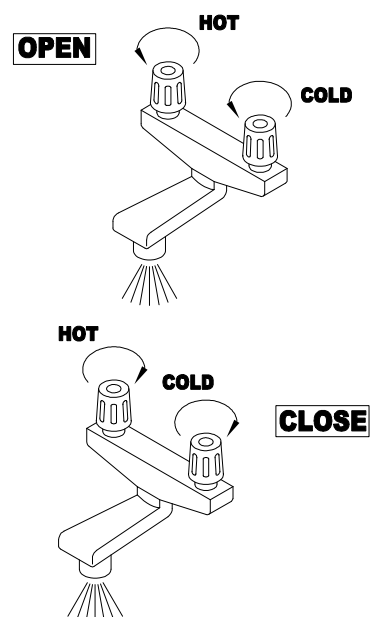

How To Use The Front Control Interface

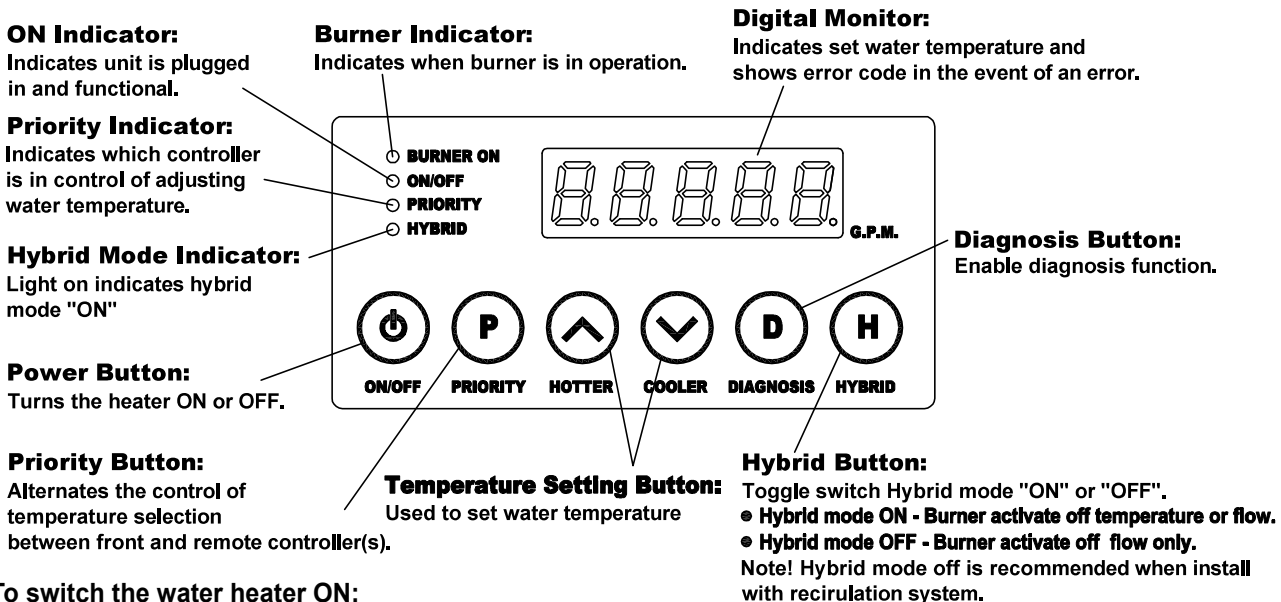

- To switch the water heater ON:**
From OFF condition Press the Power Button.
 - The temperature selected will be indicated on the Digital Monitor.
 - The ON Indicator will light up.
- When running the water by opening the water tap, the water heater will start the burner automatically and the Digital Monitor will show the Burner ON indicator.
- To switch the water heater OFF:**
Press the Power Button.
 - The temperature selected on the Digital Monitor will go out.
 - The ON Indicator will turn off.
- To adjust water temperature:**
 - Press the "HOTTER" or "COOLER" Temperature Setting Button with unit ON. (Temperature setting is only adjustable when the burner is not in use.)
 - The maximum water temperature setting can be limited by DIP switches. This manual setting overrides adjustable temperature settings on the front panel. Please call Grand Hall USA for DIP switch setting instructions if needed.

CAUTION

- Per some state laws – water temperature should not be set higher than 120°F. Please check with your local codes to ensure temperature is properly set.

DANGER

- Hot water heater temperature over 125°F can cause severe burns instantly or death from scalding.
- Children, disabled and elderly are at the highest risk of being scalded.
- Feel water temperature before bathing or showering.
- Temperature limiting valves are available; please ask a certified professional.

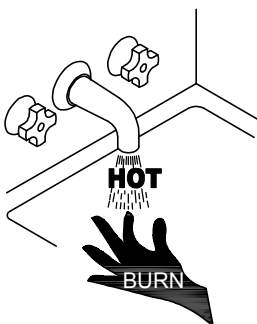

Water Temperature	Time to Produce a Serious Burn
120°F	More than 5 minutes
125°F	1.5 to 2 minutes
130°F	About 30 seconds
135°F	About 10 seconds
140°F	Less than 5 seconds
145°F	Less than 3 seconds
150°F	About 1.5 seconds
155°F	About 1 seconds

How To Use the Remote Controller

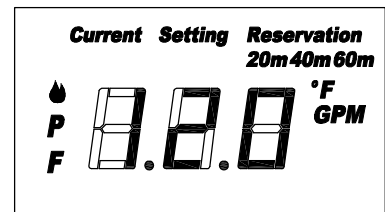
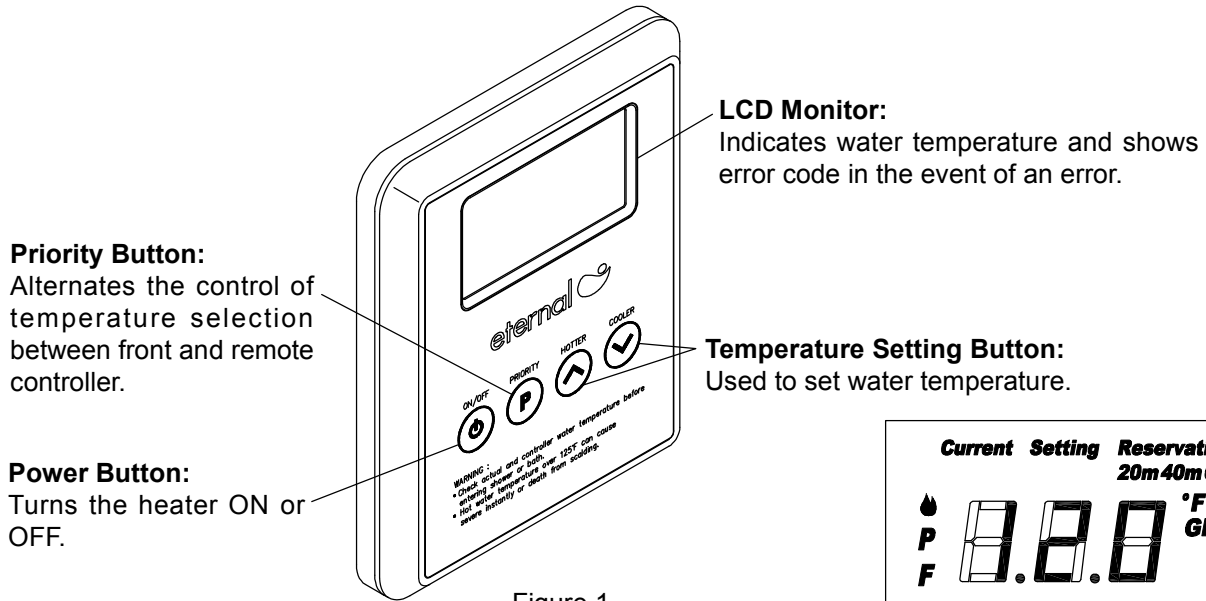

1. To switch the water heater ON with Remote Controller, from OFF condition Press the Power Button.
 - The temperature selected will be indicated on the LCD Monitor on the remote controller.
2. When running the water by opening the tap, the water heater will start the burner automatically and the burner indicator will light up the remote controller. When water taps are closed, the unit will stop the burner and burner indicator will be off on the remote controller.
3. To switch the water heater OFF with remote controller, press the power button.
 - The LCD Monitor and the ON indicator should go off on the remote controller.
4. To adjust the water temperature : Press either the Hotter(up) or Cooler(down) temperature setting button with the unit ON (temperature setting is only adjustable when the burner is not in use)
5. To lock the remote controller : Press the priority button with the unit ON. The priority indicator should light and now temperature can only be adjusted at the remote control; control cannot be transferred while burner is ON.



NOTICE



The maximum water temperature setting can be limited by DIP switches. This manual setting overrides remote control temperature setting.

Ignition Cycle Counter

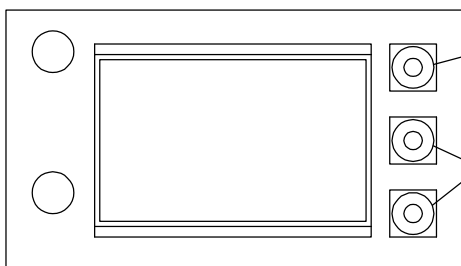

Display Toggle Button
(Total cycle count / Total burner on time)

Setting
(WARNING! CANNOT RESET OR RESTORE. Do not touch unless consulted with the manufacture first. Fail to comply the warning will void warranty)

Each Eternal water heater is equipped with built-in Ignition Cycle Counter located on the main controller board. Excessive cycles caused by improper application voids warranty. For more detail about the acceptable cycle limit, please refer to the Grand Hall Limited Warranty.

Maintenance and Service



WARNING



Turn off the electrical power supply, the manual gas control valve, and the manual water control valve before servicing.

SYSTEMS AND PARTS CHECK

- The unit should be checked once a year or as necessary by a certified and trained technician. If repairs are needed, the repairs should be done by a certified and trained technician.
- The following systems and parts should be checked at least once a year.
 1. Venting system
 2. Burner
 3. Manual operation of the pressure relief valve to ensure correct operation
 4. Periodic cleaning of the water strainer.
 5. Remove the thermistor from unit and check for mineral coating - A mineral coating on the thermistor requires cleaning
- Physical Damage:** If the water heater has been subjected to fire, flood, or physical damage, turn off the manual gas shutoff valve and do not operate the water heater again until it has been checked by qualified personnel.
- Temperature Setting:** Hotter water increases the risk of scalding injury.
- Venting System Inspection:** A visual inspection should be made on the venting system at least once a year.
 - Be sure the venting is properly connected to prevent escape of dangerous flue gases which could cause deadly asphyxiation.
 - Obstructions could cause improper venting. The combustion and ventilation air flow must not be obstructed.
 - Damage or deterioration which could cause improper venting or leakage of combustion byproducts.
- Clean Up:** The flue outlet and the air intake hole on the top of the water heater should be checked. Clean as needed to prevent the entry of water, insects, rodents or other foreign materials such as fallen leaves and dust that could cause blockages. Do not obstruct the flow of combustion air and exhaust air flow.
- Water Strainer:** The water strainer should be checked once a year. It protects valve from dirt and pipe scale. Self-clean by opening valve or hose connected to a blow-off outlet.
- Sediment Build-up:** Unlike a typical storage tank, this heater has a self cleaning system initiated by the flow of water. Build up of sediment in faucet aerators, shower heads and screens could impair water flow and cause the water heater to deliver less than its full output, or to shut down completely. Check any of these screens or shower heads on your faucets periodically and clean as necessary.
- BURNER IGNITION:** Water heater has automatic ignition system. Once you open a hot water tap, the computer electronically ignites the burners. You can see the burner flame via flame inspection hole.

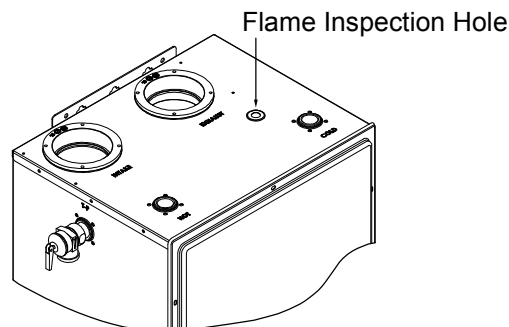

- Clean out of Condensate Trap:** Over time, blockage of the trap by debris may occur, when the condensate cannot be released, the unit will go into error and will shut down. When this occur, the condensate trap must be cleaned.
- Service & Cleaning Of The Burner:** Only specially trained and authorized personnel are permitted to service the burner.

"D" button Diagnostic Function

Applicable Model:

GU100 / 508(11,12,21,22)1100

Description:

Enhanced diagnostic functions are now available with the touch of a button. Simply press the "D" button on the front control panel to access features such as: inlet and outlet temperatures, air temperature inside the chassis, fan motor RPMs, error code history and more!

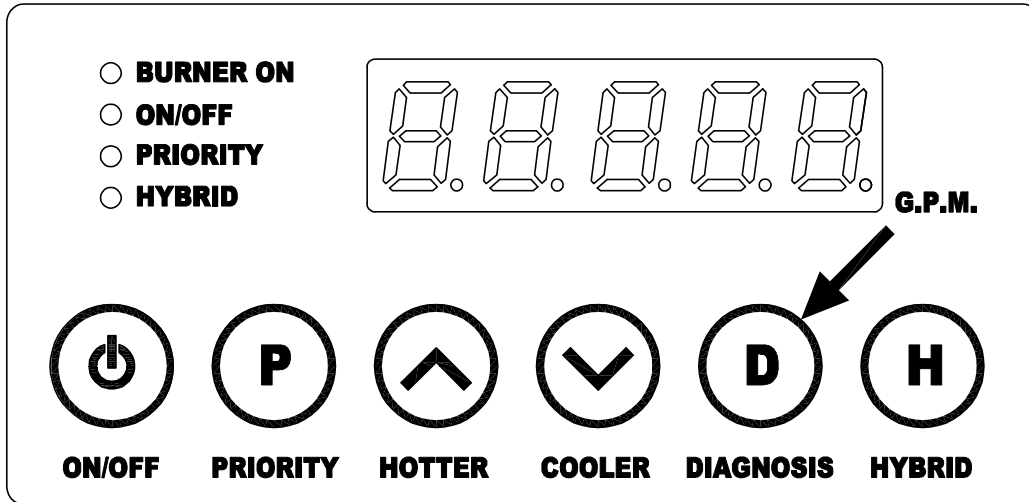

Press the "D" button when the unit is in standby mode (burner off):

Diagnostic Content	Example	Explanation
Software Version for CPU A	SA 01	CPU A running version 1
Software Version for CPU B	SB 01	CPU B running version 1
E1 through E9	E2 13	Error 2 in history is code 13

Press the "D" button when the unit is firing (burner on):

Diagnostic Content	Example	Explanation
Outlet Temperature – O	O 125	Outlet is 125°F
Heat Exchanger Temperature – H	H 135	Heat exchanger is 135°F
Inlet Temperature – I	I 65	Inlet is 65°F
Air Temperature – A	A 60	Air is 60°F
Fan Motor RPM – P	P5800	Fan is spinning at 5800 RPMs

To exit diagnostic mode, simply press the "D" button at any time to return to normal display mode. You can still access the GPM flow rate data by simply pressing either the UP or DOWN button when the unit is in normal display mode and the burner is on.

DIAGNOSTICS

Before calling for service, review the following diagnostic steps first for saving time and money!

Question	Answer
Burner does not ignite when the hot water is opened.	1. Make sure that the ON/OFF button on the front or remote controller has been turned ON.
	2. If the monitor on the front or remote controller is blank, make sure the power cord is plugged in and the 3A fuses on the main controller in the unit are good.
	3. Make sure water is flowing to the unit. The unit activates once the inlet water flow is over 0.5 gpm.
	4. Make sure the cold and hot water lines are not plumbed in the wrong locations.
	5. Make sure that the water lines are not frozen.
	6. Make sure that the cold water and gas supply lines are opened.
Water is not hot enough.	1. Check the setting temperature on the unit is not too low
	2. Make sure that the filter in the cold water supply line is not clogged with debris.
	3. Make sure that the gas supply type is correct.
	4. Check the supply and manifold gas pressures are in accordance with specifications.
	5. Make sure that the water flow sensor with three wires has been properly connected.
Water is too hot.	1. Make sure that the setting temperature on the unit is not too hot.
	2. Make sure that the filter in the cold water supply line is not clogged with debris.
	3. Make sure that the gas supply type is correct
Hot water temperature fluctuates at the opened tap.	1. Make sure the filter in the cold water supply line is clean.
	2. Make sure that the gas supply type is correct.
	3. Check the supply gas pressure is sufficient.
Abnormal sounds come from unit during operation.	1. A leak of combustion gas between sealed chamber and exhaust tube inside the unit.
	2. Improper venting termination, make sure that the venting termination complies with specifications.
	3. Make sure the supply gas pressure is sufficient. Insufficient gas pressure will cause unstable burner flame and noise.
The blower is still operating after the combustion stops.	1. This is normal because the blower still keeps operating for 1 minute to exhaust the flue gas from the chamber once the combustion has stopped.
I Can't change the setting temperature to above 140°F on the front controller.	1. This is a safety device to prevent scalding. Hot water temperature over 125°F can cause severe burns instantly or death.

DIAGNOSTICS

Self Monitoring

This unit has the ability to check its own operation continuously. If an error occurs, a message will flash on the digital monitor of the front panel.

This assists with diagnosing the error, and may enable you to overcome a problem without a service call. Please quote the code displayed when inquiring about service.

Code display	Cause	Remedy
E1	<input type="checkbox"/> Remaining flame detected	<input type="checkbox"/> Call service center
E2	<input type="checkbox"/> Ignition failure - doesn't detect flame signal	<input type="checkbox"/> Check gas line, ignitor, flame rod <input type="checkbox"/> Check wire connection of 8p wire and ignitor wire <input type="checkbox"/> Check ignition noise <input type="checkbox"/> Check gas type and manifold pressure
E3	<input type="checkbox"/> Abnormal combustion -after detection of flame signal, system lose the signal	<input type="checkbox"/> Check the gas supply in enough <input type="checkbox"/> Check the gas valve <input type="checkbox"/> Check wire connection of 8p wire and ignitor wire <input type="checkbox"/> Check gas type and pressure are correct <input type="checkbox"/> Check power supply for proper voltage
E4	<input type="checkbox"/> An outlet thermistor open	<input type="checkbox"/> Check the outlet thermistor <input type="checkbox"/> Check wire connection of 14p wire and thermistor wire
E5	<input type="checkbox"/> An outlet thermistor short	<input type="checkbox"/> Check the outlet thermistor <input type="checkbox"/> Check wire connection of 14p wire and thermistor wire
E6	<input type="checkbox"/> A H/E thermistor open	<input type="checkbox"/> Check the H/E thermistor <input type="checkbox"/> Check wire connection of 14p wire and thermistor wire
E7	<input type="checkbox"/> A H/E thermistor short	<input type="checkbox"/> Check the H/E thermistor <input type="checkbox"/> Check wire connection of 14p wire and thermistor wire
E8	<input type="checkbox"/> An inlet thermistor open	<input type="checkbox"/> Check the inlet thermistor <input type="checkbox"/> Check wire connection of 14p wire and thermistor wire
E9	<input type="checkbox"/> An inlet thermistor short	<input type="checkbox"/> Check the inlet thermistor <input type="checkbox"/> Check wire connection of 14p wire and thermistor wire
E11	<input type="checkbox"/> A DC motor failure	<input type="checkbox"/> Check DC motor <input type="checkbox"/> Check wire connection of 6p wire
E13	<input type="checkbox"/> No filled water in tank or pressure switch failure	<input type="checkbox"/> Check the water filled in tank <input type="checkbox"/> Check water pressure switch <input type="checkbox"/> Check connection of 14p wire and water pressure wire
E23	<input type="checkbox"/> Adjust control valve is not connected	<input type="checkbox"/> Check the adjust control valve movement noise <input type="checkbox"/> Check wire connection of 16p wire and adjust valve wire
E24	<input type="checkbox"/> Mixing control valve is not connected	<input type="checkbox"/> Check the mixing control valve movement noise <input type="checkbox"/> Check wire connection of 16p wire and mixing valve wire
E26	<input type="checkbox"/> Adjust control valve initialization failure	<input type="checkbox"/> Check the adjust control valve movement noise <input type="checkbox"/> Check wire connection of 16p wire and adjust valve wire
E27	<input type="checkbox"/> Mixing control valve initialization failure	<input type="checkbox"/> Check the mixing control valve movement noise <input type="checkbox"/> Check wire connection of 16p wire and mixing valve wire
E28	<input type="checkbox"/> Power line of main gas valve is open	<input type="checkbox"/> Check the thermostat <input type="checkbox"/> Check the thermal fuse <input type="checkbox"/> Check the air pressure switch <input type="checkbox"/> Check wire connection of gas valve, thermostat, thermal fuse and air pressure switch
E30	<input type="checkbox"/> Rotation of a DC fan is too high	<input type="checkbox"/> Call service center

DIAGNOSTICS

Code display	Cause	Remedy
E31	<input type="checkbox"/> Rotation of a DC fan is too low	<input type="checkbox"/> Call service center
E36	<input type="checkbox"/> A controller failure concerning gas valve	<input type="checkbox"/> Call service center
E37	<input type="checkbox"/> Communication failure with SUB CPU	<input type="checkbox"/> Call service center
E38	<input type="checkbox"/> Subsidiary RAM failure	<input type="checkbox"/> Call service center
E39	<input type="checkbox"/> A controller failure concerning Subsidiary flame signal	<input type="checkbox"/> Call service center
E40	<input type="checkbox"/> Main RAM failure	<input type="checkbox"/> Call service center
E41	<input type="checkbox"/> A controller failure concerning flame signal	<input type="checkbox"/> Call service center
E42	<input type="checkbox"/> Main ROM failure	<input type="checkbox"/> Call service center
E43	<input type="checkbox"/> Main MUX error	<input type="checkbox"/> Call service center
E47	<input type="checkbox"/> Intake Thermistor Short	<input type="checkbox"/> Check the intake thermistor <input type="checkbox"/> Check wire connection of 14p wire and thermistor wire
E48	<input type="checkbox"/> Intake Thermistor Open	<input type="checkbox"/> Check the intake thermistor <input type="checkbox"/> Check wire connection of 14p wire and thermistor wire
E49	<input type="checkbox"/> Intake Thermistor Detect Abnormal Situation	<input type="checkbox"/> Call service center
E50	<input type="checkbox"/> Room A Thermistor Short (only hydro heating)	<input type="checkbox"/> Check the room A thermistor <input type="checkbox"/> Check wire connection of 12p wire and thermistor wire
E51	<input type="checkbox"/> Room A Thermistor Open (only hydro heating)	<input type="checkbox"/> Check the room A thermistor <input type="checkbox"/> Check wire connection of 12p wire and thermistor wire
E52	<input type="checkbox"/> Room B Thermistor Short (only hydro heating)	<input type="checkbox"/> Check the room B thermistor <input type="checkbox"/> Check wire connection of 12p wire and thermistor wire
E53	<input type="checkbox"/> Room B Thermistor Open (only hydro heating)	<input type="checkbox"/> Check the room B thermistor <input type="checkbox"/> Check wire connection of 12p wire and thermistor wire
E54	<input type="checkbox"/> Current Leak on Gas Valve Power	<input type="checkbox"/> Check gas valve <input type="checkbox"/> Check connection of gas valve wire
E56	<input type="checkbox"/> Less than 0.3gpm of water flow at recirculation mode and hydro heating	<input type="checkbox"/> Check flow sensor <input type="checkbox"/> Check recirculation pump and loop <input type="checkbox"/> Check connection of 14p wire and flow sensor wire
E57	<input type="checkbox"/> Pump is not connected	<input type="checkbox"/> Check wire connection of 8p wire and pump wire <input type="checkbox"/> Check the pump
E93	<input type="checkbox"/> Master can't have any data on CAN line	<input type="checkbox"/> Check connection of 3p wire and MCU wire <input type="checkbox"/> Check connection of termination wire and resistor(120 Ω)
E94	<input type="checkbox"/> Sub can't have any signal from master	<input type="checkbox"/> Check connection of 3p wire and MCU wire <input type="checkbox"/> Check connection of termination wire and resistor(120 Ω)

NOTE: In all cases you may be able to clear the Error Message simply by turning the hot water tap OFF, then ON again. If this does not clear the Error Message, try pushing the ON/OFF button OFF, then ON again. If the Error Message still remains, contact our service center or your nearest service agent and arrange for a service call.

1-866-946-1096

8am-4pm CST, Monday through Friday

How To Check Gas Combustion

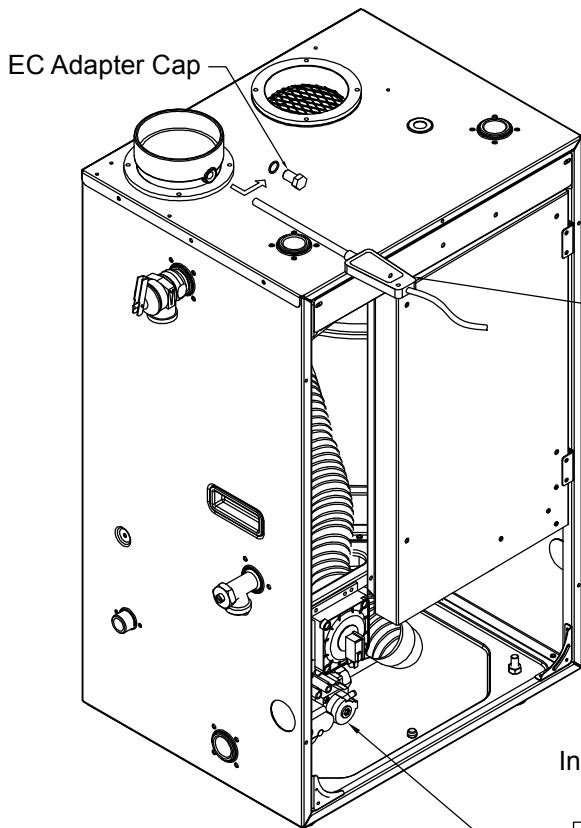

⚠

NOTICE

⚠

Using a combustion analyzer is required for checking and tuning the gas valve.

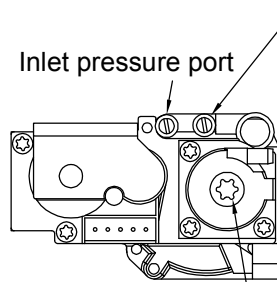
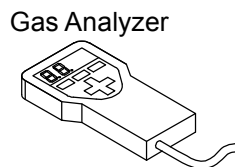

Please loosen the 1/8" NPT screw and check the manifold pressure by using a manometer with 0.01" W.C. resolution. Please check the inlet pressure to ensure the incoming gas pressure is within unit's required specification. Min and Max inlet and manifold pressures are indicated on the Eternal OM and Rating label.

Adjustment screw A (Tool: T40 torx bit)

⚠

WARNING

⚠

The combustion testing and adjustments must be performed by a qualified installer, service agency or the gas supplier. All combustion analyzer must be performed with calibrated equipment to ensure proper reading and accuracy.

If the combustion levels are not within the range given in Table 1 for the firing rate, shut the unit and contact Eternal Engineering support team. Failure to comply with this requirement could result in severe personal injury, death or substantial property damage.

After setting, the CO level should not exceed maximum 200 ppm for both Natural and Propane gas.

Recommended Combustion Levels for low fire

Setting values O ₂ / CO ₂				
Model	Gas type			
	Natural gas		Propane gas	
	O ₂	CO ₂	O ₂	CO ₂
GU100	3.0 - 6.5%	8.0 - 10.0%	3.5 - 6.9%	9.0 - 11.0%

(Table 1)

How To Check Gas Combustion

Procedure for high firing

Note : During this procedure you will only observe the reading and will not make any adjustment.

Unscrew the EC adopter cap on vent collar (see to above diagram) and connect the flue gas analyzer.

- **Set to full load:** with the unit at 130°F or higher, force the unit into high fire by opening demand of at least 7 GPM water flow rate.
- Wait 10 seconds for modulation to stabilize with the full-load fan speed, measure the CO level. It should not exceed 200 ppm for both natural and propane gas.
- Check the flame through the sight glass which should be stable with a regular flame distribution.

Setting procedure for low firing

- **Set to low load:** Turn dipswitch #3 in group 3 to ON and throttle demand down to no more than 2 GPM water flow rate.
- Wait at least 10 seconds for modulation to stabilize with the low-load fan speed, measure the O₂/CO₂ percentage and compare this to values in table 1.
- If the values are not in accordance with the table then correct the gas/air ratio valve using the adjusting screw A on gas valve.
- If the value is too low turn the adjusting screw A clockwise; this increases the gas rate - if the value is too high turn the screw anti clockwise which decrease the gas rate.
- Flip dipswitch #3 in group 3 to OFF.
- Cold flush the unit and let it take itself through at least 1 cycle on standby fire for boot up diagnostics.
- Check the flame through the sight glass which should be stable with a regular flame distribution.
- Reinstall the flue stack cap when finished testing.



NOTICE



Only make small adjustments of the adjusting screw maximum 1/8 turns at a time when setting O₂/CO₂. Ensure that the analyzing probe has a gas tight seal in the sampling point with the probe end in the centre of the flue duct.



NOTICE



HOW TO CHECK GAS SUPPLY PRESSURE

1. Turn off power source and turn off gas supply to the unit.
2. Remove the front cover from the unit.
3. Loosen the gas supply pressure test port screw and connect manometer to this port; turn on the gas to the water heater.
4. Turn the water heater on and open multiple taps to force unit into high fire; check gas supply pressure at the test port with a manometer with unit in high fire.



WARNING



- Manifold Gas Pressure should only be adjusted on low fire.
- If gas supply pressure drops below 3.5" WC unit will not have enough gas volume for max fire!

Wiring and Connection Diagram

Wiring Diagram MODEL : GU100 / 508(11,12,21,22)1100

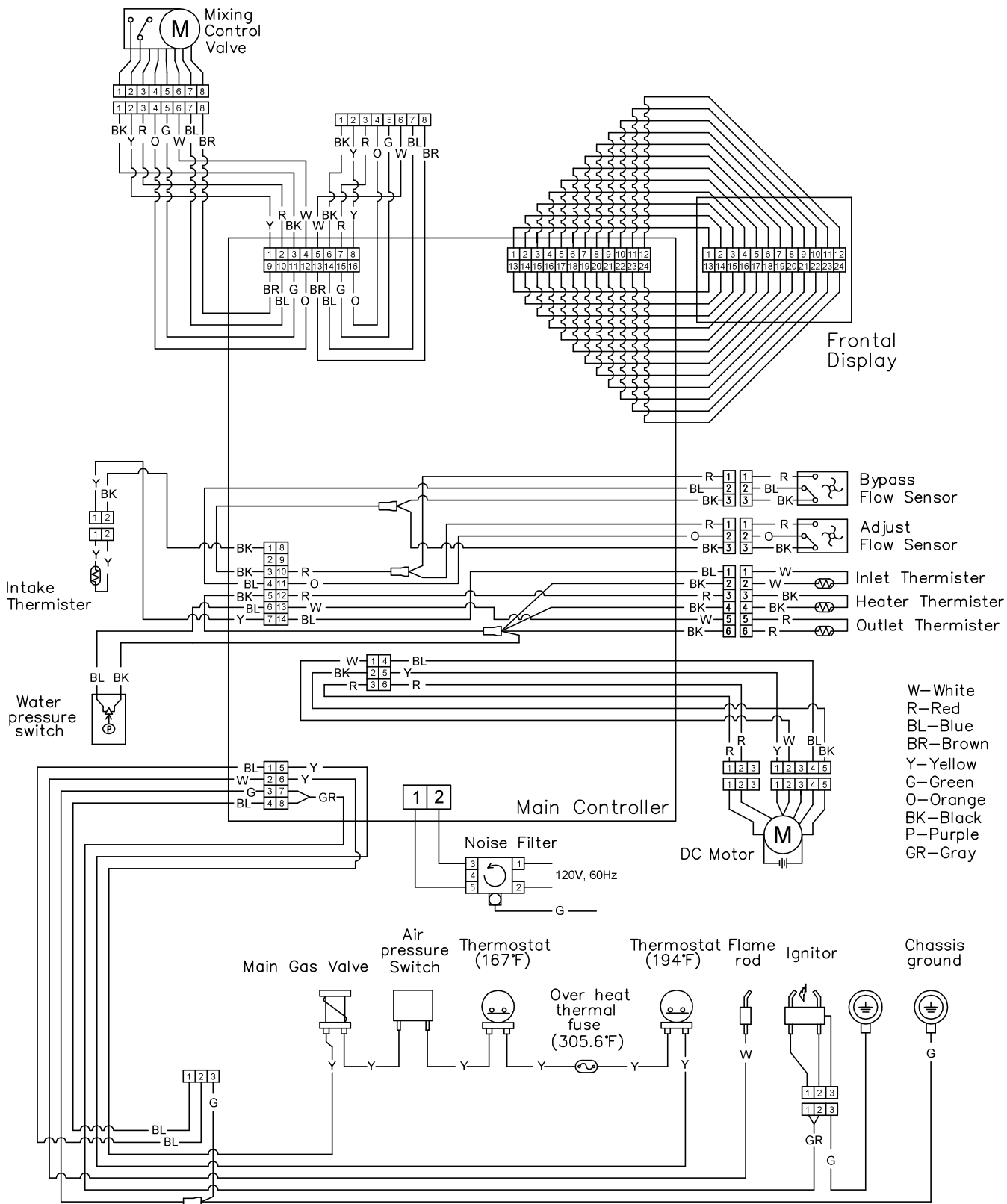

Grand Hall Limited Warranty

General Terms of Limited Warranty for Product

Grand Hall will warrant to the purchaser of this gas water heater at the ORIGINAL INSTALLED LOCATION that it will be free of defects in material, workmanship and performance when used with Potable Water* and when installed and used in strict compliance with Grand Hall's specifications, for the applicable period shown in Warranty Periods below. *See **DEFINITIONS** below.

Warranty Exclusions

This product warranty does not apply in the event of product failure or operating difficulties due to accident, abuse, misuse, alteration, Misapplication,* Improper Installation,* vandalism, lack of maintenance or service, and Acts of God. **See the *Installation Operation Manual ("Manual")*** for additional details. This warranty does not apply in the event of deterioration or damage due to severe weather or exposure to chemicals, either directly or in the atmosphere. *See **DEFINITIONS** below.

This warranty applies only if the water heater is installed by a licensed contractor. This warranty does not apply if the water heater is purchased over the internet. This warranty does not apply if the water heater is re-installed to a location other than the original installed location.

Environmental conditions outside of normal product specifications such as gas pressure, water quality, piping materials, pump sizing, wind level, and operating noise complaints are not covered by this warranty. See the **Manual** for additional details.

Exclusive Remedy

Your exclusive remedy for any defective product is limited to the repair or replacement, at Grand Hall's option, of the product that proved to be defective under normal use utilizing potable water. The replacement product will carry out the remainder of the warranty from the originally installed product.

Proof of Purchase

Grand Hall will require reasonable proof of your purchase. Save your dated receipt in case it is required as proof of purchase. You may also show proof of purchase by registering within 30 days of purchasing the product at www.eternalwaterheater.com. Registration constitutes proof of purchase, but registration is not required in order to validate this warranty.

Limitation of Damages

Grand Hall's entire liability for any defective product shall in no event exceed the purchase price for the defective product. This limitation applies even if Grand Hall cannot or does not repair or replace any defective product and your exclusive remedy fails of its intended purpose.

No Consequential or Other Damages

Notwithstanding anything else in this warranty or otherwise, Grand Hall will not be liable with respect to the product under any legal theory, including without limitation contract, negligence, strict liability or other legal or equitable theory (i) for any amount in excess of the purchase price for the defective product, or (ii) for any general, consequential, punitive, incidental or special damages. These include damages from interruption of use, lost profits, the cost of the installation or removal of any products, the cost of installation of replacement products, and any costs of inspection, testing, or redesign caused by any defect, or caused by the repair or replacement of other products arising from a defect in any this product. This section does not limit liability for bodily injury of a person. **In the United States, some states do not allow the exclusion or limitation of incidental or consequential damages, so the above exclusion or limitation may not apply to you. This warranty gives you specific legal rights, and you may also have other rights which vary from state to state.**

Limitation on Implied Warranties

There are no warranties which extend beyond the face of this Grand Hall Limited Warranty. Grand Hall disclaims all other warranties expressed or implied, regarding the product, including any implied warranties of merchantability, fitness for a particular purpose or non-infringement. **In the United States, some states do not allow the exclusion of the implied warranties so the above exclusion may not apply to you. Some states do not allow limitations on how long an implied warranty lasts, so any such limitation may not apply to you.**

For additional warranty details, including procedures for obtaining warranty service, please consult the **Warranty Service Policy**.

Grand Hall Limited Warranty

Limited Labor Allowance

Grand Hall will provide a pre-set labor allowance as set forth in the following table, which shall be paid to the licensed contractor who obtains written authorization or a Work Order from Grand Hall in advance, strictly for repairs or replacements for warranty-covered defects occurring within one (1) year from the date of purchase.

Contractor's Authorization Level*	Repair or Replacement Labor Allowance - Part	Replacement Labor Allowance - Entire Unit
Unregistered Installer	\$0	\$75
F.A.C.T. Registered	\$75	\$150
F.A.S.T. Registered	\$150	\$300

*See **DEFINITIONS** below.

All warranty work must be authorized by Grand Hall through a Work Order in order to be eligible for payment, as described in the ***Warranty Service Policy***.

What's covered by the Limited Labor Allowance

Covered: Labor incurred for the completed repair or replacement of a component or product that has failed due to a manufacturing defect in the component or product.

What's not covered by the Limited Labor Allowance

Not covered: Corrections due to failure to follow installation instructions in the ***Manual***; reset-able error codes not caused by a component or product failure; adjustments made on a product or component that should have been checked at time of installation, such as (but not limited to) insufficient or excessive gas pressure; repair or replacement resulting from misapplication of the product, such as (but not limited to) under-sizing, wrong gas type, use with non-potable water; and damages resulted from mishandling, transit, natural disasters, electrical surges and/or Acts of God.

Grand Hall is not responsible for any labor charge incurred on non-warranty work performed by the contractor.

Warranty Periods

Warranty Periods for Heat Exchanger

The warranty period for the Heat Exchanger expires upon the first of the following events to occur:

1. 15 years for Residential use;
2. 5 years for Commercial use;
3. 365,000 total ignition cycles*

* No more than 300 ignition cycles in any one day, which averages to about one cycle every 5 minutes.

Note: GU100 models are solely for Residential use and the warranty is voided if used for Commercial use.

See **DEFINITIONS** below for "Commercial" and "Residential."

• *Warranty Periods for other Components*

Product Warranty: The maximum term of the limited warranty on parts, other than the Heat Exchanger, is three (3) years from date of purchase. Grand Hall offers an extended warranty for parts, other than the Heat Exchanger, of two (2) additional years, free of charge, if the product is registered online at www.etalwaterheater.com.

Warranty Period for Labor Allowance

Labor Allowance: The term of the limited labor allowance is one (1) year from date of purchase, paid through Work Orders issued to authorized contractors, as described in the ***Limited Warranty and Service Policies Guide***.

Grand Hall Limited Warranty

DEFINITIONS

1. **F.A.C.T.** (Factory Authorized Contractor Trained) – A licensed contractor who has been through the basic installation class held by either an Eternal Sales Representative or Grand Hall factory personnel, who has registered his/her company on the Eternal Dashboard system, and who has passed the authorization test.
2. **F.A.S.T.** (Factory Authorized Service Trained) – A licensed contractor who has already received his/her F.A.C.T. authorization and ID, who has elected to take the higher level training class provided by Grand Hall including a step-by-step product breakdown, and who has passed the authorization test.
3. **Improper Installation** – Product not installed in accordance with the instructions set forth in the **Operator’s Manual**, including but not limited to usage of non-approved materials or plumbing connections, use of dielectric unions, improper venting, failure to follow local codes, or improper gas supply.
4. **Misapplication** – Product installed on a job where the hot water usage is not in line with product’s primary intended function: to supply sufficient potable domestic hot water in accordance with the factory performance and installation specifications set forth in the **Operator’s Manual**, including but not limited to: undersized system where product cannot meet peak demand, plumbed in manifold with another brand of water heater, disregarding Grand Hall sizing recommendations, power venting with air intake exposed to contaminated environment, closed-loop recirculation for heating applications where water is no longer potable, mismatching models of product in networked applications, or uncontrolled recirculation that causes short-cycling not in accordance with product lifecycle specifications.
5. **Residential Application** – Product installed on a single family residence where no more than one family utilizes the installed product for domestic hot water supply (under 140°F). Residential recirculation is allowed and does not impact the heat exchanger warranty if an Internal Pump Control (IPC) or external timer and aquastat are used.
6. **Commercial Application** – Product installed for commercial or multi-family domestic hot water supply, space heating applications, recovery of storage tank applications, continuous recirculation with timer and aquastat controls, and sanitation purposes (above 140°F).
7. **Potable Water** – Public utility or well supplied drinkable water in compliance with EPA secondary maximum contaminant levels (40 CFR part 143.3), as follows:

Contaminant	Allowable Limits	Contaminant	Allowable Limits
Aluminum	0.2 mg/L	Manganese	0.05 mg/L
Chloride	250 mg/L	Iron	0.3 mg/L
Copper	1.0 mg/L	Fluoride	2.0 mg/L
pH	6.5 – 8.5	Sulfate	250 mg/L

Grand Hall will warrant the heat exchanger against leaks when used normally with water meeting the above EPA standard. In addition, Grand Hall will warrant against water hardness: Up to 15 grains per gallon (250ppm) for single family Residential Applications, and up to 7 grains per gallon (120ppm) for Commercial Applications.

• **How to Obtain Warranty Service**

Please contact your licensed, authorized Eternal contractor to obtain diagnostics and warranty service for your water heater. You can find authorized contractors at www.eternalwaterheater.com. Simply enter your zip code for a listing of nearby authorized contractors. Be sure to have your model number, serial number and the error code displayed on the front of the unit available for your contractor so that he/she may arrive at your location with the necessary tools and parts to remedy the situation. The contractor may contact our technical support department 24/7 toll-free at **1-866-946-1027** and we will help troubleshoot through the process. **WARRANTY SERVICE WILL BE PROVIDED ONLY IF THE SERVICE POLICIES GUIDE IS FOLLOWED.**

US Contact:
 Grand Hall USA, Inc.
 3838 W. Miller Rd.,
 Garland, TX 75041
 Toll-Free: 866-946-1096

Manufacturer:
 Grand Hall Enterprise Co., Ltd.
 9th Floor, No 298, Rueiguang Rd.
 Neihu, Taipei Taiwan (114)