

# COMMERCIAL ELECTRIC WATER HEATER

A Spanish language version of these instructions is available by contacting the company listed on the rating plate.

La versión española de estas instrucciones se puede obtener al escribirle a la fábrica cuyo nombre aparece en la placa de especificaciones.

## INSTALLATION & OPERATING INSTRUCTION MANUAL

**THE WARRANTY ON THIS WATER HEATER IS IN EFFECT ONLY WHEN THE WATER HEATER IS INSTALLED AND OPERATED IN ACCORDANCE WITH LOCAL CODES AND THESE INSTRUCTIONS. THE MANUFACTURER OF THIS HEATER WILL NOT BE LIABLE FOR ANY DAMAGE RESULTING FROM FAILURE TO COMPLY WITH THESE INSTRUCTIONS. READ THESE INSTRUCTIONS THOROUGHLY BEFORE STARTING.**

***For your family's comfort, safety and convenience, it is recommended this water heater be installed and serviced by a plumbing professional.***

# TABLE OF CONTENTS

<b>General Information .....</b>	<b>3</b>
<b>Installation .....</b>	<b>4</b>
<b>Locating The Water Heater.....</b>	<b>4</b>
<b>Water Connections .....</b>	<b>6</b>
<b>Electrical Connections .....</b>	<b>11</b>
<b>Amperage Chart .....</b>	<b>12</b>
<b>GPH Recovery Capacities .....</b>	<b>12</b>
<b>General Operation .....</b>	<b>13</b>
<b>Thermostat Adjustment.....</b>	<b>14</b>
<b>Maintenance.....</b>	<b>16</b>
<b>Notes .....</b>	<b>19</b>

## **CONGRATULATIONS!**

**You have just purchased one of the finest water heaters on the market today!**

**This installation, operation and instruction manual will explain in detail the installation and maintenance of your new Commercial Electric Water Heater. The Manufacturer strongly recommends that you contact a plumbing professional for the installation of this water heater.**

**We require that you carefully read this manual, as well as the enclosed warranty, and refer to it when questions arise. If you have any specific questions concerning your warranty, please consult the plumbing professional from whom your water heater was purchased. For your records we recommend that you write the model, serial number and installation date of your water heater in the maintenance section in the back of this manual.**

**This manual should be kept with the water heater.**

## GENERAL INFORMATION

The design of this electric water has been listed with Underwriters' Laboratories, Inc. (UL) as complying with UL standard UL1453.

This water heater must be installed in accordance with local codes. In the absence of local codes, install this water heater in accordance with the N.E.C. Reference Book (latest edition).

The warranty for this water heater is in effect only when the water heater is installed, adjusted and operated in accordance with these Installation and Operating Instructions. The manufacturer will not be held liable for damage resulting from alteration and/or failure to comply with these instructions.

This water heater has been designed and listed for the purpose of heating potable water. The installation and use of this water heater for any purpose other than the heating of potable water may cause damage to the water heater and create a hazardous condition and nullify the warranty.

### CAUTION

**Incorrect operation of this appliance may create a hazard to life and property and will nullify the water.**

Do not use this appliance if any part has been under water. Immediately call a qualified service technician to inspect the appliance and to replace any part of the control system and/or any gas control, which has been under water. Depending upon individual circumstances, it may be necessary to replace the entire water heater.

Make sure that the rating plate on the water heater is referenced for certainty that the correct voltage is being supplied to the water heater.

### DANGER

**Do not store or use gasoline or other flammable, combustible or corrosive vapors and liquids in the vicinity of this or any other appliance.**

**General Information continued-**

A sacrificial anode(s) is used to extend tank life. Removal of any anode, for any reason, will nullify the warranty. In areas where water is unusually active, an odor may occur at the hot water faucet due to a reaction between the sacrificial anode and impurities in the water. If this should happen, an alternative anode(s) may be purchased from the supplier that installed this water heater. This will minimize the odor while protecting the tank. Additionally, the water heater should be flushed with appropriate dissolvers to eliminate any bacteria.

**IMPORTANT**

Before proceeding, please inspect the water heater and its components for possible damage. DO NOT install any damaged components. If damage is evident, please contact the supplier where the water heater was purchased or the manufacturer listed on the rating plate for replacement parts.

**INSTALLATION**

**Locating The Water Heater**

**⚠ WARNING**

Water heaters are heat-producing appliances. To avoid damage or injury, there must be no materials stored against the water heater and proper care must be taken to avoid unnecessary contact (especially by children) with the water heater. **UNDER NO CIRCUMSTANCES SHALL FLAMMABLE MATERIALS, SUCH AS GASOLINE OR PAINT THINNER BE USED OR STORED IN THE VICINITY OF THIS WATER HEATER OR ANY LOCATION FROM WHICH FUMES COULD REACH THE WATER HEATER.**

**This water heater MUST be installed indoors out of the wind and weather.**

**This water heater must NOT be installed in any location where gasoline or flammable vapors are likely to be present, unless the installation is such to eliminate the ignition of gasoline or flammable vapors.**

The location for the installation of this water heater is of utmost importance. Before installing this water heater, consult the installation section of these instructions. After reading these installation and operating instructions, select a location for the water heater where the floor is level and is easily accessible to a power supply and water connections.

### **Locating The Water Heater continued-**

It is recommended that the water heater be located near the center of greatest hot water usage to prevent heat loss through the pipes. **DO NOT locate the water heater where water lines could be subjected to freezing temperatures. Locate the water heater so that access panels and drain valves are accessible.**

Water heater corrosion and component failure can be caused by the heating and breakdown of airborne chemical vapors. Examples of some typical compounds that are potentially corrosive are: spray can propellants, cleaning solvents, refrigerator and air conditioning refrigerants, swimming pool chemicals, calcium or sodium chloride, waxes and process chemicals. These materials are corrosive at very low concentration levels with little or no odor to reveal their presence. **NOTE: DAMAGE TO THE WATER HEATER CAUSED BY EXPOSURE TO CORROSIVE VAPORS IS NOT COVERED BY THE WARRANTY. DO NOT OPERATE THE WATER HEATER IF EXPOSURE HAS OR WILL OCCUR. DO NOT STORE ANY POTENTIALLY CORROSIVE COMPOUNDS IN THE VICINITY OF THE WATER HEATER.**

This water heater must be located in an area where leakage of the tank or water line connections and the combination temperature and pressure relief valve will not result in damage to the area adjacent to the water heater or to lower floors of the structure. When such locations cannot be avoided, a suitable drain pan must be installed under the water heater. The drain pan must have a minimum length and width of at least 4 in. (10.2 cm) greater than the diameter of the water heater. The drain pan, as described above, can be purchased from your plumbing professional. The drain pan must be piped to an adequate drain. The piping must be pitched for proper drainage.

To comply with NSF requirements this water heater is to be:

- a) Sealed to the floor with sealant, in a smooth and easily cleanable way, or
- b) Installed with an optional leg kit that includes legs and/or extensions that provide a minimum clearance of 6" beneath the water heater.

**Note: For California installation this water heater must be braced, anchored, or strapped to avoid falling or moving during an earthquake. See instructions for correct installation procedures. Instructions may be obtained from the DSA Headquarters Office, 1102 Q Street, Suite 5100, Sacramento, CA 95811.**

## Water Connections

**NOTE: BEFORE PROCEEDING WITH THE INSTALLATION, CLOSE THE MAIN WATER SUPPLY VALVE.**

After shutting the main water supply valve, open a faucet to relieve the water line pressure to prevent any water from leaking out of the pipes while making the water connections to the water heater. After the pressure has been relieved, close the faucet. The cold water inlet line connects to the inlet nipple at the base of the water heater. The hot water outlet line connects to the nipple on top of the water heater. The fittings at the cold water inlet and hot water outlet are dielectric waterway fittings with tapered male threads. Make the proper plumbing connections between the water heater and the plumbing system in the structure. Install a shut-off valve in the cold water supply line.

### CAUTION

If sweat fittings are to be used, **DO NOT** apply heat to the nipples on top of the water heater. Sweat the tubing to the adapter before fitting the adapter to the water connections. It is imperative that heat is not applied to the nipples containing a plastic liner.

### IMPORTANT

**FAILURE TO INSTALL AND MAINTAIN A NEW, LISTED TEMPERATURE-PRESSURE RELIEF VALVE WILL RELEASE THE MANUFACTURER FROM ANY CLAIM, WHICH MIGHT RESULT FROM EXCESSIVE TEMPERATURE AND PRESSURES.**

If this water heater is installed in a closed water supply system, such as one having a back-flow preventer in the cold water supply, provisions shall be made to control thermal expansion. DO NOT operate this water heater in a closed system without provisions for controlling thermal expansion. Your water supplier or local plumbing inspector should be contacted on how to control this situation.

After installation of the water lines, open the main water supply valve and fill the water heater. While the water heater is filling, open several hot water faucets to allow air to escape from the water system. After a steady stream of water flows from the faucets, close them and check all water connections for possible leaks. **NEVER OPERATE THE WATER HEATER WITHOUT FIRST BEING CERTAIN IT IS FILLED WITH WATER.**

**▲ WARNING**

For protection against excessive temperatures and pressure, install temperature and pressure protective equipment required by local codes, but not less than a combination temperature and pressure relief valve certified by a nationally recognized testing laboratory that maintains periodic inspection of production of listed equipment or materials, as meeting the Requirements for *Relief Valves and Automatic Gas Shutoff Devices for Hot Water Supply Systems, ANSI Z21.22*, and the Standard *CAN1-4.4 Temperature, Pressure, Temperature and Pressure Relief Valves and Vacuum Relief Valves*. The combination temperature and pressure relief valve must be marked with a maximum set pressure, not to exceed the maximum working pressure of the water heater. The combination temperature and pressure relief valve shall also have an hourly rated temperature steam BTU discharge capacity not less than the hourly input rating of the water heater.

Install the combination temperature and pressure relief valve into the opening provided and marked for this purpose on the water heater

Note: Some models may already be equipped or supplied with a combination temperature and pressure relief valve. Verify that the combination temperature and pressure relief valve complies with local codes. If the combination temperature and pressure relief valve does not comply with local codes, replace it with one that does. Follow the installation instructions above on this page.

Install a discharge line so that water discharged from the combination temperature and pressure relief valve will exit within six (6) inches (15.3 cm) above, or any distance below the structural floor and cannot contact any live electrical part. The discharge line is to be installed to allow for complete drainage of both the temperature and pressure relief valve and the discharge line. The discharge opening must not be subjected to blockage or freezing. **DO NOT** thread, plug or cap the discharge line. It is recommended that a minimum of four (4) inches (10.2 cm) be provided on the side of the water heater for servicing and maintenance of the combination temperature and pressure relief valve.

Do not place a valve between the combination temperature and pressure relief valve and the tank.

**⚠ WARNING**

Hydrogen gas can be produced in a hot water system served by this water heater that has not been used for a long period of time (generally two weeks or more). Hydrogen gas is extremely flammable. To reduce the risk of injury under these conditions, it is recommended that the hot water faucet be opened for several minutes at the kitchen sink before using any electrical appliance connected to the hot water system. If hydrogen is present, there will probably be an unusual sound such as air escaping through the pipe as the water begins to flow. There should be no smoking or open flame near the faucet at the time it is open.


**⚠ CAUTION**

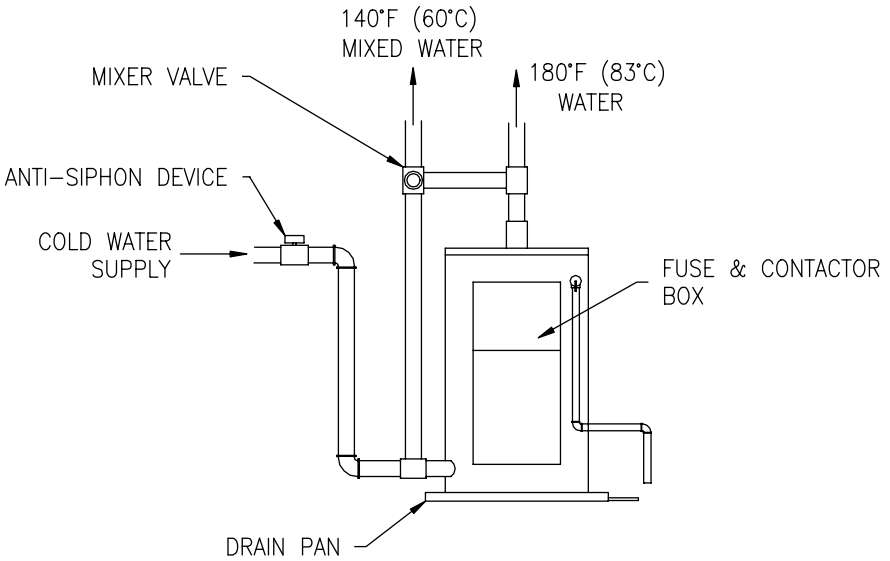
**INCREASING THE THERMOSTAT SETTING ABOVE THE PRESET TEMPERATURE MAY CAUSE SEVERE BURNS AND CONSUME EXCESSIVE ENERGY. HOTTER WATER INCREASES THE RISK OF SCALD INJURY.**

This water heater can deliver scalding temperature water at any faucet in the system. Be careful whenever using hot water to avoid scalding injury. Certain appliances, such as dishwashers and automatic clothes washers, may require increased temperature water. By setting the thermostat on this water heater to obtain increased temperature water required by these appliances, you might create the potential for scald injury. To protect against injury, you should install an ASSE approved mixing valve in the water system. This valve will reduce point of discharge temperature by mixing cold and hot water in branch supply lines. Such valves are available from the manufacturer of this water heater or a local plumbing supplier. Please consult with a plumbing professional.



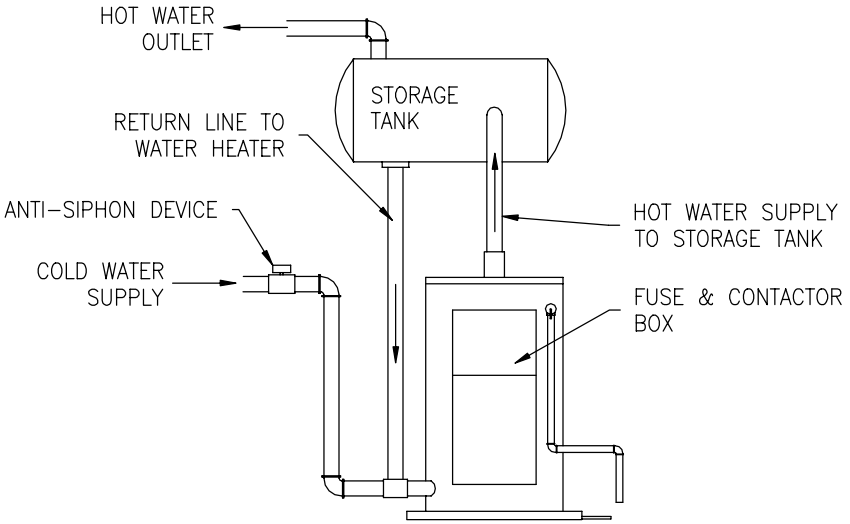
**Water Connections continued-**

	<p>Water temperature over 125°F can cause severe burns instantly or death from scalds. Children, disabled and elderly are at highest risk of being scalded.</p> <p>Review this instruction manual before setting temperature at water heater.</p> <p>Feel water before bathing or showering.</p> <p>Temperature limiting valves are available.</p>
---	--

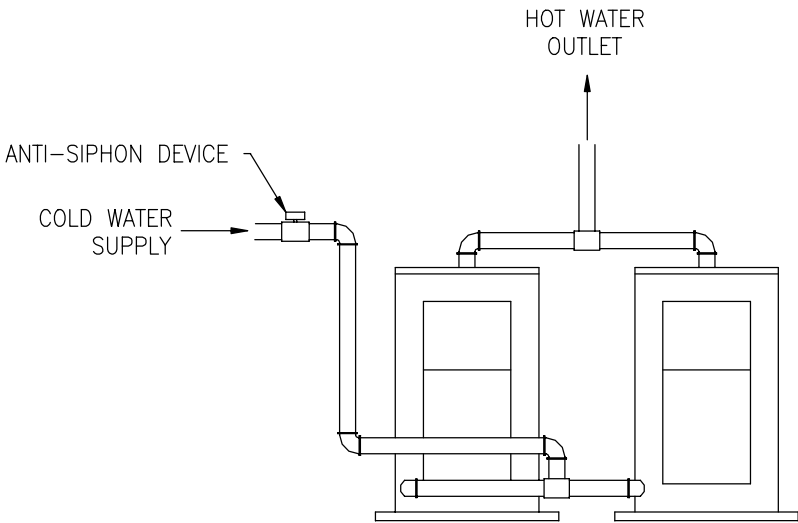


**Figure 1**  
**(Dual Temperature System With Mixing Valve)**

**Water Connections continued-**



**Figure 2  
(Single Installation With Storage Tank Gravity Circulation)**



**Figure 3  
(Dual Water Heater Installation)**

## Electrical Connections

Before any electrical connections are made, be sure that the water heater is full of water and that the manual shut-off valve in the cold water supply line is open. If the heating elements are not completely immersed in water at all times, they will be damaged (burned-out) if energized for even a short period of time. The warranty does not cover burned-out heating elements. Check the rating plate and wiring diagram before proceeding. This electric water heater was built and wired in accordance with the Underwriters Laboratories testing approvals requirements. The temperature-limiting device is of the manual reset, trip-free type and has been factory installed to interrupt all ungrounded power supply conductors in the event of thermostat failure. The plumbing supplier in your area ordered this water heater wired at the factory to comply with existing area codes, but local utility codes may require or allow other circuitry. Consult your local power company to determine the correct electrical hook-up in order to meet local utility and building codes and in order to obtain the most economical rates. All electrical connections to elements, thermostats, and contactors (certain models) have been made at the factory. **DO NOT** alter any of the internal wiring. Wiring connections may loosen during shipment. Check all connections for tightness.

To make the wiring connections to a power supply, follow the steps below.

- A) Open cover door of the control box.
- B) Bring the power leads from an adequately fused disconnect switch (not furnished with the water heater due to varying state and local codes) and connect to the terminal block. Where long runs, local ordinances or utility company necessitates, an increase in size may be required.
- C) This water heater must be properly grounded. A ground lug is provided within the electrical control box for connection to a properly sized ground. (See wiring diagram for minimum required ground size. Wiring diagram is located on the inside door of the control box)
- D) Close cover door of the control box.

## Heating Elements

To replace heating elements, disconnect power to the water heater, drain tank and replace element. To remove a heating element, use a 1 1/2" screw type element wrench available from most supply houses. **Do not** over-tighten the new element, as this will cause distortion in the new element gasket. Once the element has been replaced, follow the instructions "To Fill The Water Heater". It is imperative that the water heater is full before power is restored to the heating elements.

**Electrical Connections continued-**

**Amperage Chart**

kW Input	208V		240V		277V	380V	415V	480V	
	1Ø	3Ø	1Ø	3Ø	1Ø	3Ø	3Ø	1Ø	3Ø
6	29	17	25	14	22	9	8	12	7
9	43	25	38	22	32	14	13	19	11
12	58	33	50	29	43	19	17	25	14
13.5	65	38	56	32	49	21	19	28	16
15	72	42	63	36	54	23	21	31	18
18	87	50	75	43	65	28	25	38	22
24	115	67	100	58	87	37	34	50	29
27	130	75	113	65	97	41	38	56	32
30	144	83	125	72	108	46	42	63	36
36	173	100	150	87	130	55	50	75	43
45	216	125	188	108	162	69	63	94	54
54	260	150	225	130	195	83	75	113	65

Water heaters with amperage draw of 48 AMPS or more require factory installed internal fusing to comply with Underwriters Laboratories requirements.

**GPH Recovery Capacities**

kW Input	Temperature Rise								
	40°F	50°F	60°F	70°F	80°F	90°F	100°F	120°F	140°F
6	62	50	41	35	31	28	25	21	18
9	93	74	62	53	47	41	37	31	27
12	124	99	83	71	62	55	50	41	35
13.5	140	112	93	80	70	62	56	47	40
15	155	125	103	89	78	69	62	52	44
18	186	149	124	106	93	83	74	62	53
24	248	199	164	142	124	110	99	83	71
27	279	223	186	160	140	124	112	93	80
30	310	248	207	177	155	138	124	103	89
36	372	298	248	213	186	165	149	124	106
45	465	372	310	266	233	207	186	155	133
54	558	447	372	319	279	248	223	186	160

Multiply kW input by 3,412 to determine BTU input:

Example: 54kW x 3412 = 184,248 BTU's

**Recovery Computation Formula**

$$\text{GPH} = (\text{watts} \times 3.412) / (8.25 \times \text{°Temp. Rise})$$

## GENERAL OPERATION

Before closing the switch to allow electric current to flow to the water heater, make certain that the water heater is full of water and that the cold water inlet valve is open. Complete failure of the heating elements will result if they are not totally immersed in water at all times. When the switch is closed, the operation of this electric water heater is automatic. The thermostat(s) are preset to provide a water temperature of approximately 140°F (60°C) or below. Care must be taken whenever using hot water to avoid scalding injury. Certain appliances require high temperature hot water (such as dishwashers and automatic clothes washers).

### CAUTION

Scalding may occur within five (5) seconds at a temperature setting of 140°F (60°C).

#### TO FILL THE WATER HEATER

1. Close the water heater drain valve by turning the knob clockwise.
2. Open the cold water supply shut-off valve.
3. Open several hot water faucets to allow air to escape from the system.
4. When a steady stream of water flows from the faucets, the water heater is filled. Close the faucets and check for water leaks at the water heater drain valve, combination temperature and pressure relief valve and the hot and cold water connections.
5. Reconnect power supply to water heater.

#### TO DRAIN THE WATER HEATER

Should it become necessary to completely drain the water heater, make sure you follow the steps below:

1. Disconnect the power supply to the water heater. Consult the plumbing professional or electric company in your area for service.
2. Close the cold water supply shut-off valve.
3. Open the drain valve on the water heater by turning the knob counter-clockwise. The drain valve has threads on the end that will allow connection of a standard hose coupling.
4. Open a hot water faucet to allow air to enter the system.

To refill the water heater, refer to "TO FILL THE WATER HEATER."

## Thermostat Adjustment

There are two types of thermostats this electric water heater may come equipped with from the factory. One type, surface mounted thermostats, directly contacts the water heater tank surface (see Figure 4). The second type, immersed type are immersed within the water heater tank and uses contactor type relays. Before any work is done on the water heater, disconnect all power to the water heater by opening the switch at the main electrical circuit breaker or fuse box. **Before adjusting or setting surface mounted type thermostat(s), disconnect all power to the water heater.** To gain access to the surface mounted thermostat(s), remove the outer access panel and fiberglass insulation. Using a screwdriver rotate the thermostat dial on each thermostat clockwise to increase the water temperature. After adjusting the surface mounted thermostats, replace the fiberglass insulation making sure that the controls are well covered and that the plastic terminal shield has not been displaced; replace the access panel. Once the water heater has been filled with water, electrical power may be restored to the water heater and the water heater is ready for operation. To adjust or set the water temperature for water heaters using immersed type thermostat(s), locate the temperature control dial on the right side of the lower control box. To increase the water temperature, rotate the temperature control dial clockwise (see Figure 5). The thermostat(s) or temperature control dial has been factory preset to approximately 140°F (60°C) or below.

### DANGER

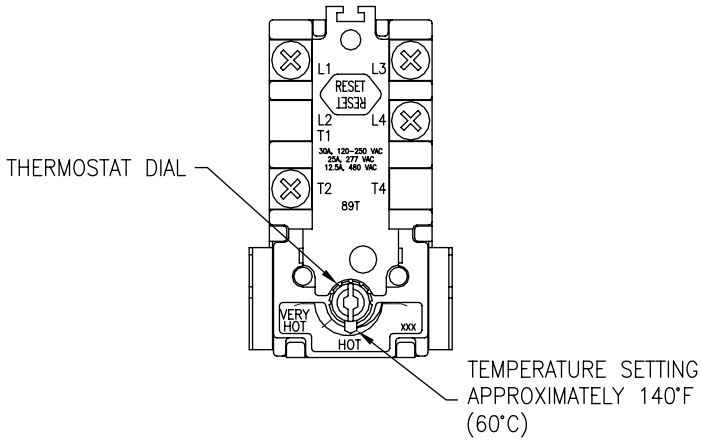
Hotter water increases the risk of scald injury. Scalding may occur within five (5) seconds at a temperature setting of 140°F (60°C). To protect against hot water injury, install an ASSE approved mixing valve in the water system. This valve will reduce point of discharge water temperatures by mixing cold and hot water in branch water lines. A licensed plumbing professional or local plumbing authority should be consulted.

Note: This water heater is equipped with an energy cut out device to prevent overheating. Should overheating occur, turn off the electrical supply to the water heater and contact a qualified service technician.

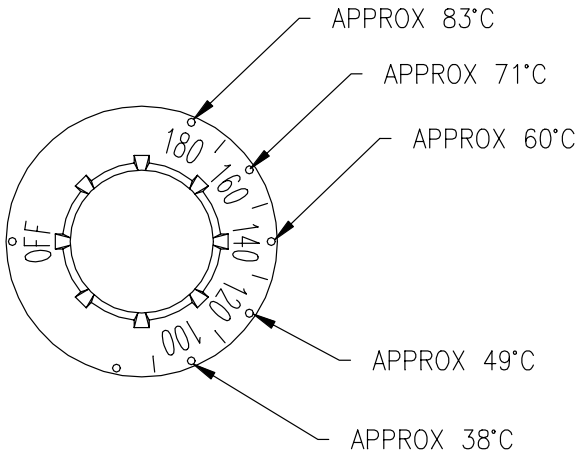
#### APPROXIMATE TIME/TEMPERATURE RELATIONSHIPS IN SCALDS

120°F (49°C)	More than 5 minutes
125°F (52°C)	1½ to 2 minutes
130°F (54°C)	About 30 seconds
135°F (57°C)	About 10 seconds
140°F (60°C)	Less than 5 seconds
145°F (63°C)	Less than 3 seconds
150°F (66°C)	About 1½ seconds
155°F (68°C)	About 1 second

**Thermostat Adjustment continued-**



**Figure 4**



**Figure 5**

## MAINTENANCE

### IMPORTANT

The water heater should be inspected at a minimum of annually by a qualified service technician for damaged components. **DO NOT** operate this water heater if any part is found damaged.

Shut off the electric power whenever the water supply to the water heater is off. Shut off the electric power and water supply, drain the heater completely to prevent freezing whenever the building is left unoccupied during the cold weather months. In order to insure efficient operation and long tank life, drain the water heater at least once a month through the drain valve until the water runs clear. Failure to do this may result in noisy operation and lime and sediment buildup in the bottom of the tank. Check the temperature-pressure relief valve to insure that the valve has not become encrusted with lime. Lift the lever at the top of the valve several times until the valve seats properly without leaking and operates freely.

### WARNING

When lifting lever of temperature-pressure relief valve, hot water will be released under pressure. Be certain that any released water does not result in bodily injury or property damage. The magnesium anode rod should be inspected periodically and replaced when necessary to prolong tank life.

The following, maintenance should be performed by a qualified service technician at the minimum periodic intervals suggested below. In some installations, the maintenance interval may be more frequent depending on the amount of use and the operating conditions of the water heater. Regular inspection and maintenance of the water heater will help to insure safe and reliable operation.

1. Annually, check the operation of the thermostat(s).
2. Bi-annually, check the seal around the heating elements for leaks. If there is any sign of leaking, disconnect the power supply to the water heater and contact the plumbing professional that installed this water heater or a qualified service technician.



**Maintenance continued-**

3. At least once a year, check the combination temperature and pressure relief valve to insure that the valve has not become encrusted with lime. Lift the lever at the top of the temperature-pressure relief valve several times until the valve seats properly without leaking and operates freely.

**▲ WARNING**

When lifting lever of temperature-pressure relief valve, hot water will be released under pressure. Be certain that any released water does not result in bodily injury or property damage.

4. If the combination temperature and pressure relief valve on the appliance discharges periodically, this may be due to thermal expansion in a closed water supply system. Contact the water supplier or local plumbing inspector on how to correct this situation. **Do not plug the combination temperature and pressure relief valve outlet for any reason.**
5. Monthly, drain off a gallon of water from the water heater to remove silt and sediment.

**▲ WARNING! THIS WATER MAY BE HOT.**

6. A combination sacrificial anode rod/hot water outlet nipple has been installed to extend tank life. The anode rod should be inspected periodically (every 2 years) and replaced when necessary to prolong tank life. Water conditions in your area will influence the time interval for inspection and replacement of the anode rod. Contact the plumbing professional who installed the water heater or the manufacturer listed on the rating plate for anode replacement information. The use of a water softener may increase the speed of anode consumption. More frequent inspection of the anode is needed when using softened (or phosphate treated) water.
7. If this water heater is equipped with fuses, before removing any fuse, disconnect the all power to the water heater. Open the upper control box door and replace fuses according to the size indicated on the wiring diagram affixed to the inside of the door.

**▲ CAUTION**

FOR YOUR SAFETY, **DO NOT** ATTEMPT TO REPAIR THERMOSTAT(S), HEATING ELEMENTS, OR ELECTRICAL WIRING. REFER SUCH REPAIRS TO A QUALIFIED SERVICE TECHNICIAN.

**Maintenance continued-**

Contact your local plumbing supplier or plumbing professional for replacement parts or contact the company at the address displayed on the rating plate of the water heater.

For faster and better service, please provide the part name, model, and serial number(s) of the water heater(s) when ordering parts.

**READ THE WARRANTY FOR A FULL EXPLANATION OF THE LENGTH OF TIME THAT PARTS AND THE WATER HEATER ARE WARRANTED.**

Manufactured under one or more of the following U.S. Patents: RE.34,534; B1 5,341,770; 4,416,222; 4,628,184; 4,669,448; 4,672,919; 4,808,356; 4,829,983; 4,861,968; 4,904,428; 5,000,893; 5,023,031; 5,052,346; 5,081,696; 5,092,519; 5,115,767; 5,199,385; 5,277,171; 5,372,185; 5,485,879; 5,574,822; 5,596,952; 5,660,165; 5,682,666; 5,761,379; 5,943,984; 5,954,492; 5,988,117; 6,142,216; 6,395,280; 6,684,821; 7,007,748; 7,063,132; Other U.S. and Foreign patent applications pending. Current Canadian Patents: 1,272,914; 1,280,043; 1,289,832; 2,045,862; 2,092,105; 2,107,012; 2,108,186; 2,112,515

Complete the following information and retain for future reference:

Model No: \_\_\_\_\_

Serial No: \_\_\_\_\_

Service Phone  
Days: \_\_\_\_\_ Nights: \_\_\_\_\_

Address: \_\_\_\_\_

Supplier: \_\_\_\_\_

Supplier Phone No: \_\_\_\_\_

# NOTES



# COMMERCIAL ELECTRIC ENERGY SAVER WATER HEATER MII SERIES

IMMERSION AND SURFACE MOUNTED  
THERMOSTAT MODELS



## SERVICE MANUAL

Troubleshooting Guide  
and Instructions for Service

(To be performed ONLY by  
qualified service providers)

### Models Covered by This Manual:

MII50(A)-\*-\*\*-(SF,CF,SCF)-\*\*\*  
MII80(A)-\*-\*\*-(SF,CF,SCF)-\*\*\*  
MII120(A)-\*-\*\*-(SF,CF,SCF)-\*\*\*

\*Denotes kW Rating

\*\*Denotes Warranty Years

\*\*\*Denotes Wiring Code

## Table of Contents

	<u>Page</u>	<u>Service Procedure</u>
Introduction .....	2	---
Tools.....	2	---
General Information .....	3	---
Sequence of Operation .....	10	---
Troubleshooting .....	13	---
Heating Element Testing .....	15	MCE-I
Line Voltage Testing.....	16	MCE-II
Fuse Testing.....	17	MCE-III
High Limit (ECO) Testing (Surface Mounted Thermostats).....	18	MCE-IV
High Limit (ECO) Testing (Surface Mounted Thermostats at 600V).....	19	MCE-V
High Limit (ECO) Testing (Contactor Models).....	20	MCE-VI
Thermostat Operation Testing (Surface Mounted Thermostats).....	21	MCE-VII
Thermostat Operation Testing (Surface Mounted Thermostats at 600V).....	22	MCE-VIII
Thermostat Operation Testing (Contactor Models).....	23	MCE-IX
Contactor Operation Testing.....	24	MCE-X
Thermostat Removal and Replacement (Surface Mounted Thermostats).....	26	MCE-XI
Thermostat Removal and Replacement (Contactor Models).....	27	MCE-XII
ECO Removal and Replacement (Contactor Models).....	28	MCE-XIII
ECO Removal and Replacement (Surface Mounted Thermostats at 600V).....	29	MCE-XIV
Heating Element Removal and Replacement .....	30	MCE-XV
Anode Inspection and Replacement .....	31	MCE-XVI
Generic Parts List .....	32	---
Glossary of Terms.....	33	---

## Introduction

This service manual is designed to aid service and maintenance professionals on the function, proper diagnosis and repair of Bradford White Commercial Electric Water Heaters.

The text and illustrations in this manual provide step by step instructions to facilitate proper operation and troubleshooting procedures. Contact the Bradford White Technical Support Group immediately if diagnosis can not be made using the methods described in this service manual.

## Tools

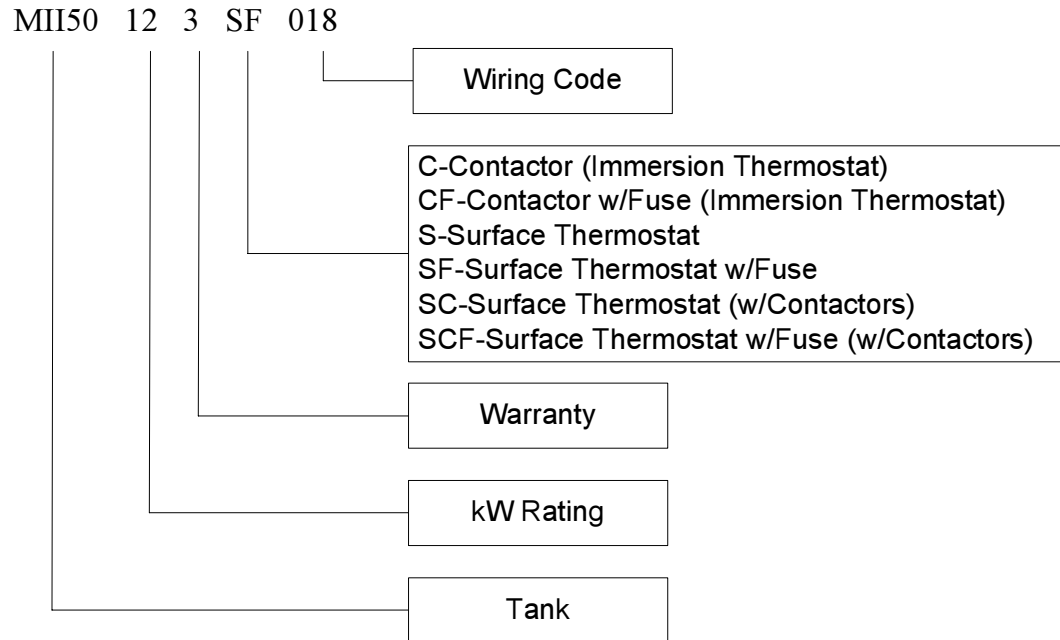
- Multi Meter.
- 1-½" Deep Well Socket.
- 1-1/16" Deep Well Socket.
- ¼" Nut Driver.
- Phillips Head Screw Driver.
- Common Screw driver.
- Thermometer.
- Drain Hose.

- Other Hand Tools: Pipe Wrench, Channel Locks, Pliers (common & needle nose), Wire cutters, Wire Strippers, Allen Wrench Set, Flash Light.

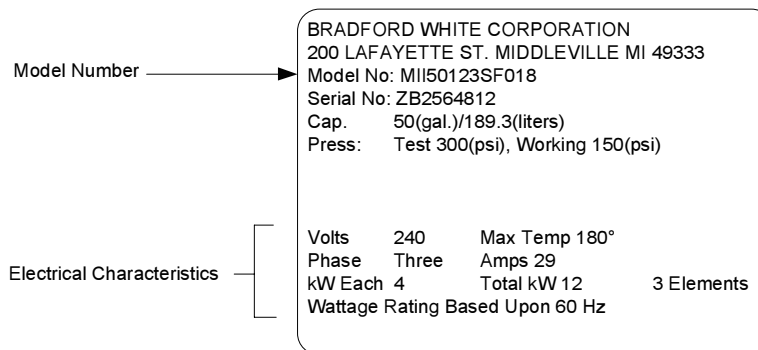
Bradford White MII Series Commercial Electric water heaters can be manufactured with a choice between two different types of thermostat control options as follows:

Surface Mounted Thermostats.  
Immersion Thermostat (contactor models).

The model number is coded to identify the specific thermostat control system used for a particular unit. Below is typical model number and coded definitions:

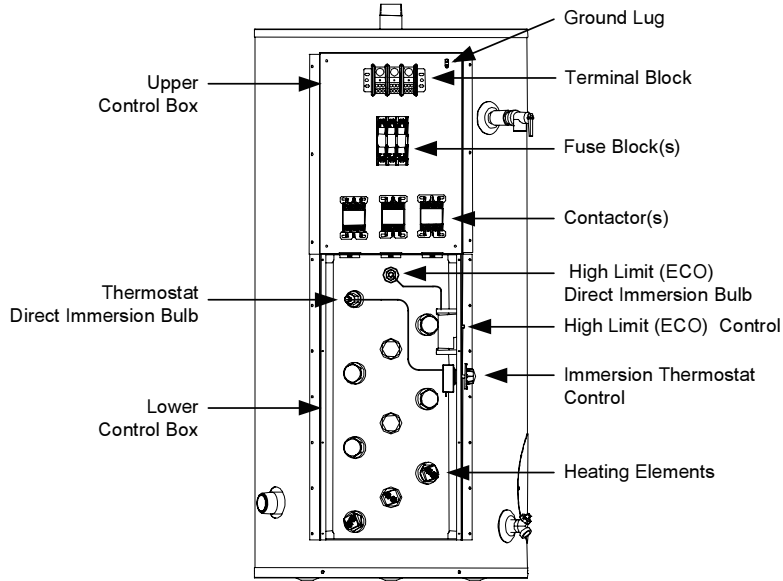


The wiring code at the end of the model number is used at the factory to facilitate proper construction based on the electrical characteristics such as voltage, phase, kW rating and amp draw. In the field this information is determined from the heaters rating plate located on the front of the water heater.

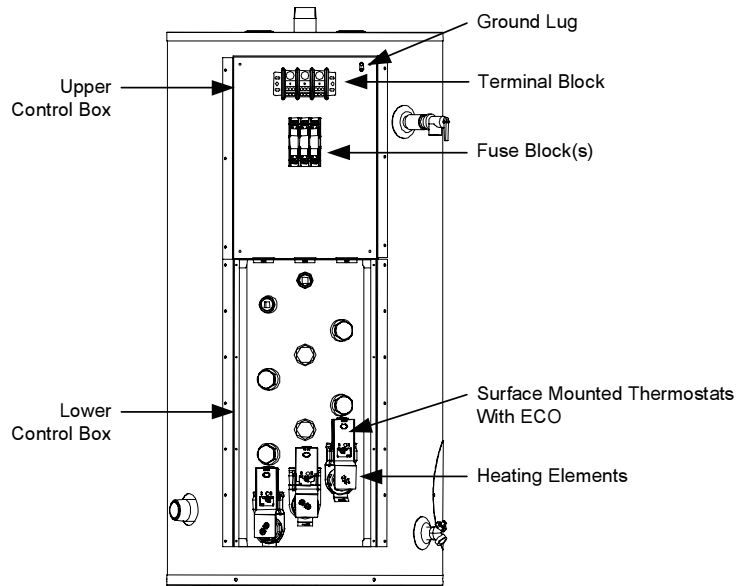


Typical Rating Plate  
Located On Front Of Water Heater

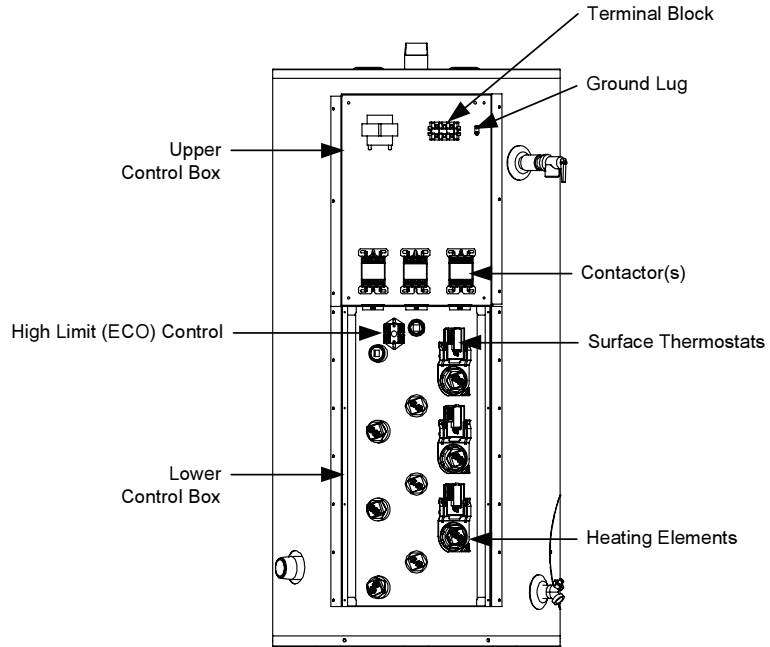
### Contactor Models General Controls Layout



### Surface Mounted Thermostat Models General Controls Layout



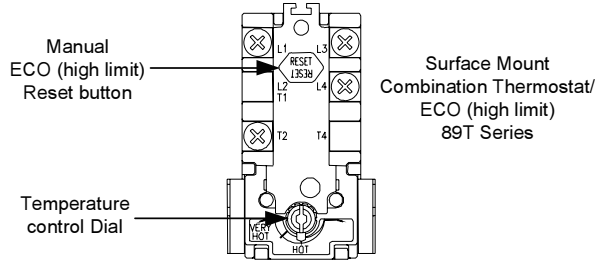
**600V Surface Thermostat (w/Contactors) Models  
General Controls Layout**





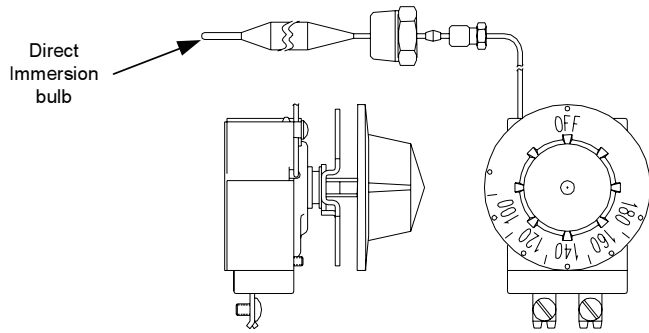
### Surface Mounted Thermostats

Surface mounted thermostats are mounted into a bracket above each heating element. The bracket holds the thermostat against the side of the tank responding to tank surface temperatures to sense a call for heat, set point temperature and high limit (ECO) activation. As each element has a dedicated thermostat (for all models excluding 600V), it is possible to sequence the elements by varying the settings on the thermostats.



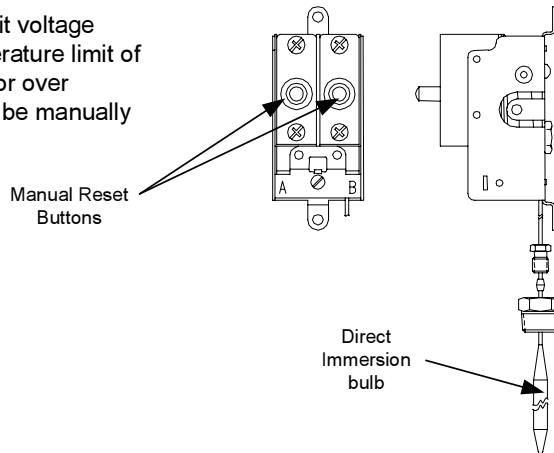
### Immersion Style Thermostat Control for Contactor Models

The thermostat will complete control circuit voltage upon a call for heat. Likewise, the control will interrupt control circuit voltage when the water temperature is sufficient to satisfy the adjustable temperature limit of control.



### Immersion Style High Limit (ECO) Control for Contactor Models

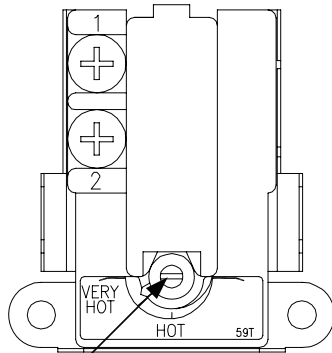
The high limit (ECO) control will interrupt control circuit voltage causing the heater to shut down when the high temperature limit of the control is reached (196°F±4°F). Once the cause for over heated water has been determined, The control must be manually reset to restore normal operation.



**Surface Mounted Thermostats (w/Contactors) for 600V Models**

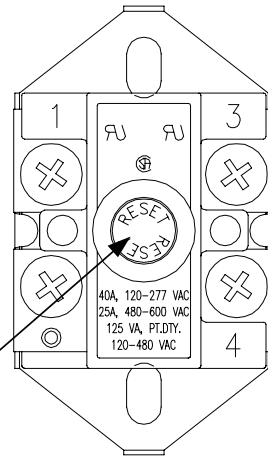
600V models use contactors to deliver line voltage to the heating elements. However, rather than the immersion type high limit and thermostat devices, surface mounted thermostats are used to operate the control circuit of the water heater.

Surface Mounted  
Thermostat  
59T Series



Temperature  
control Dial

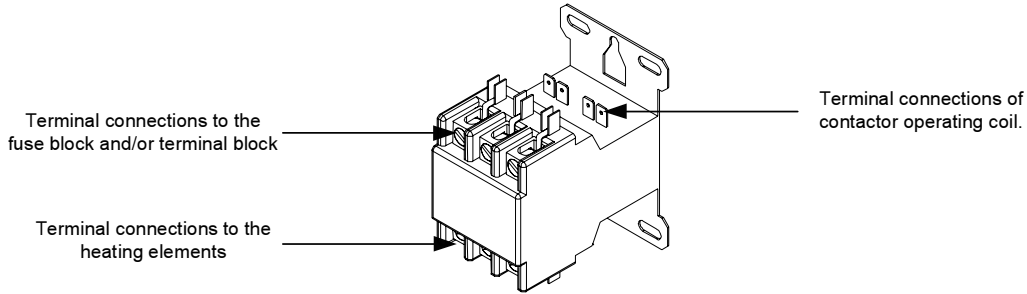
Surface Mounted  
ECO (High Limit)



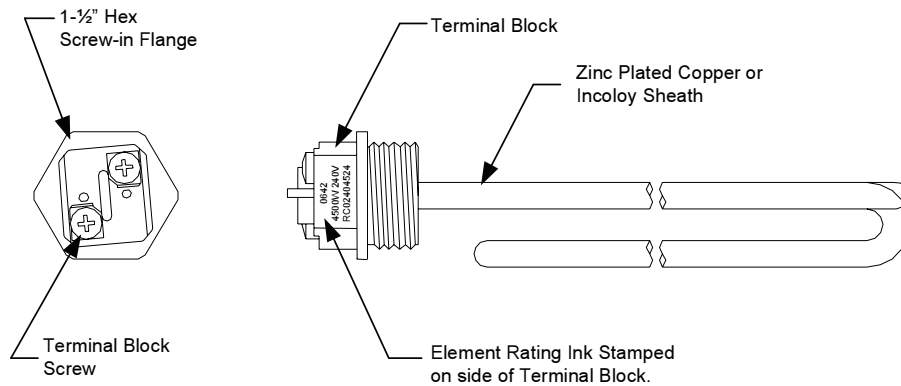
Manual Reset  
Button

**Contactor**

Contactor operation is achieved by energizing an operating coil in response to a call for heat from the immersion thermostat. Upon a call for heat, one or more contactors will energize all heating elements simultaneously. The operating coils are voltage specific, When contactor replacement is required be sure to order the proper operating coil base on the voltage rating found on the rating plate located on the front of the water heater.



**Direct Immersion “Screw-in” Type Heating Element**



**Commonly Used Formulas**

(Single phase)  

$$\text{Amps} = \frac{\text{Watts}}{\text{Volts}}$$

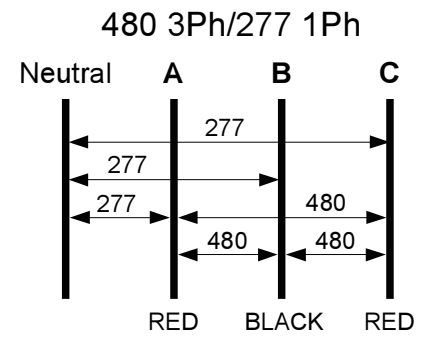
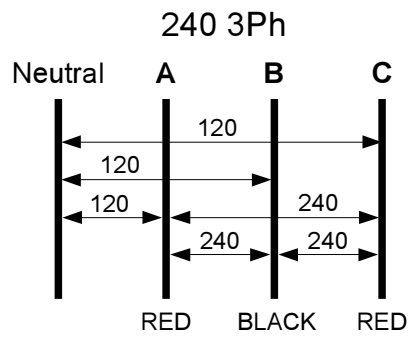
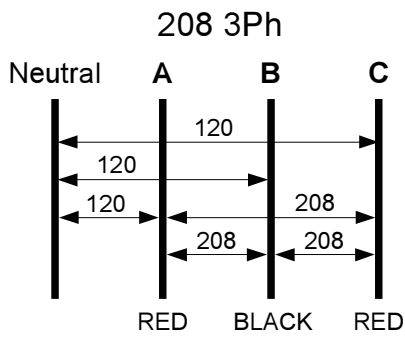
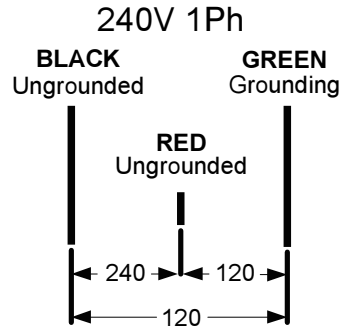
(balanced 3 phase)  

$$\text{Amps} = \frac{\text{Watts}}{\text{Volts} \times 1.732}$$

Watts = Amps x Volts

$$\text{Ohms} = \frac{\text{Volts}^2}{\text{Watts}}$$

**Common Service Wire Configurations**



**Full Load Current Amps**

kW	208 Volt		240 Volt		277 Volt	380 Volt	415 Volt	480 Volt		600 Volt
	1 Ph	3 Ph	1 Ph	3 Ph	1 Ph	3 Ph	3 Ph	1 Ph	3 Ph	3 Ph
6	28.8	16.6	25.0	14.4	21.6	9.1	8.3	12.5	7.2	5.8
9	43.2	25.0	37.2	21.6	32.4	13.6	12.5	18.7	10.8	8.7
12	57.6	33.3	50.0	28.9	43.3	18.2	16.7	25.0	14.4	11.5
13.5	64.9	37.5	56.2	32.5	48.7	20.5	18.8	28.1	16.2	13.0
15	72.1	41.6	62.5	36.1	54.1	22.7	20.9	31.2	18.0	14.4
18	86.5	50.0	75.0	43.4	64.0	27.3	25.0	37.5	21.6	17.3
24	115.4	66.7	100.0	57.8	86.6	36.4	33.4	50.0	28.9	23.1
27	129.8	75.0	112.5	65.0	97.4	41.0	37.5	56.2	32.5	26.0
30	144.2	83.3	125.0	72.2	108.3	45.6	41.7	62.5	36.1	28.9
36	173.0	100.0	150.0	86.7	129.9	54.7	50.1	75.0	43.3	34.6
45	216.3	125.0	187.5	108.3	162.4	68.4	62.6	93.7	54.1	43.3
54	259.6	150.0	225.0	130.0	194.9	82.0	75.1	112.5	65.0	52.0

MII Series Commercial Electric Water Heaters can use either **immersion thermostat** (contactor models) or **surface mounted thermostats**. Sequence of operation for each configuration is explained below. It would be impractical to show all wire diagrams applicable to both configurations. A "typical wiring diagram" is illustrated to aid in understanding the principles of the operating sequence.

**Immersion Thermostat (Contactor Models):** Configured to use a single immersion thermostat to control one or more contactors to energize or de-energize all elements simultaneously. In addition, a separate high limit (ECO) control with manual reset is wired in series with the thermostat. Both controls use a direct immersion bulb inserted into the tank to sense water temperature. Immersion thermostat and high limit control are mounted to provide temperature adjustment and manual reset access from the exterior of the unit.

**Surface Mounted Thermostats:** Surface mounted thermostats are mounted inside the lower control box, in a bracket above each heating element. The bracket holds the thermostat against the side of the tank responding to tank surface temperatures to sense a call for heat, set point temperature and high limit (ECO) activation. As each element is controlled by a dedicated thermostat, it is possible to sequence the elements by varying the settings on the thermostat. However, 600V models w/ surface mounted thermostats operate contactors in the same manner as an immersion thermostat model, only using surface thermostats to sense the call for heat.

Sequence of operation for each system is explained below.

**Sequence of Operation:  
Immersion Thermostat (Contactor Models).**

The system has two distinct circuits.

1. Power circuit (shown solid line).
2. Control Circuit (shown dotted line).

1 Line voltage is applied across terminals of fuse block or a terminal block. Line voltage continues down and connects to terminals L1, L2 & L3 of one or more contactors.

A) Contactor is open (no call for heat), so there is no voltage across terminal T1, T2 & T3 of contactor.

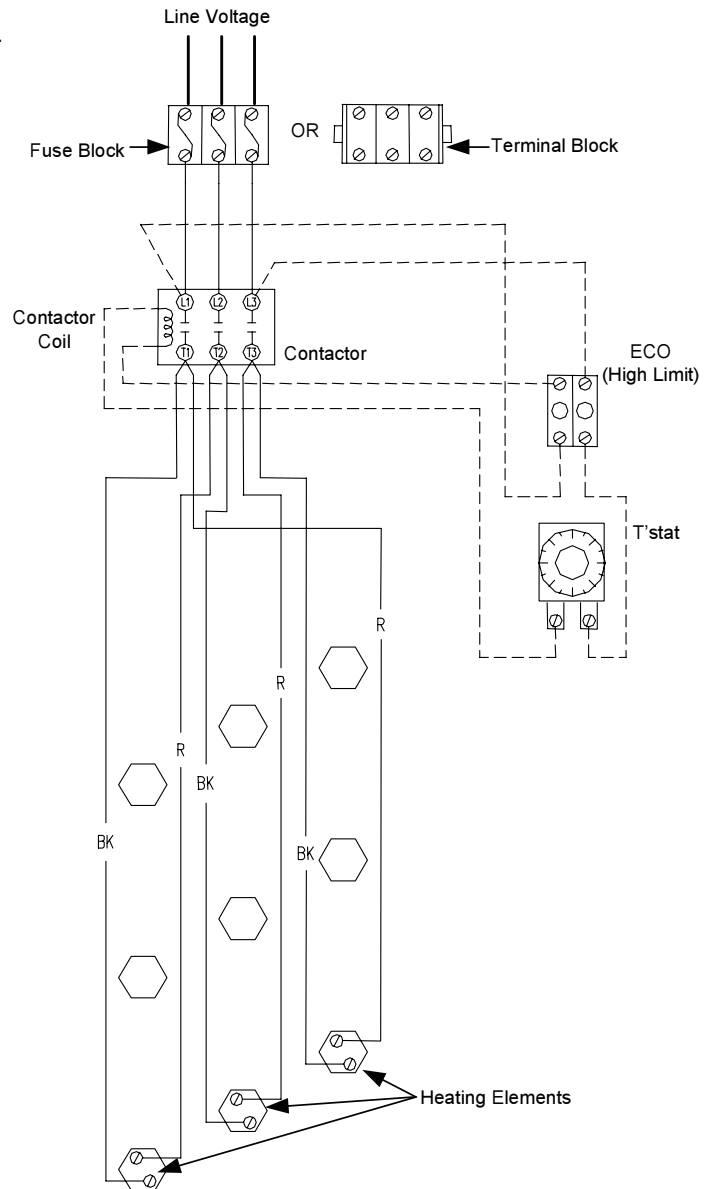
B) The contactor is controlled by the control circuit consisting of the immersion thermostat, ECO (hi limit) and contactor coil.

2 When the thermostat calls for heat, contacts close inside the thermostat completing the circuit through the ECO and energizing the contactor coil.

3 The energized contactor coil causes the contactor to close energizing the elements from terminals T1, T2 & T3 of the contactor.

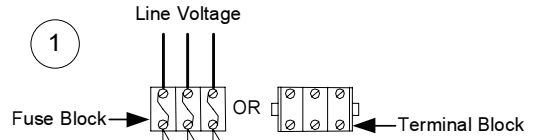
4 When the temperature setting of the thermostat is reached, the contacts in the thermostat open. This interrupts current flow through the control circuit de-energizing the contactor coil.

5 The de-energized contactor coil causes the contactor to open, interrupting current flow through the elements. The heater is now in stand-by waiting for the next call for heat.

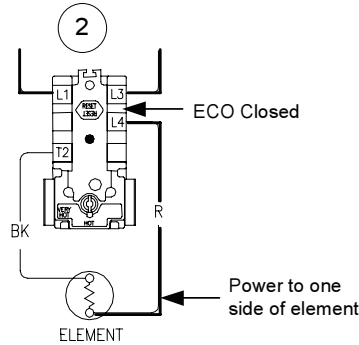


**Sequence of Operation:  
Surface Mounted Thermostats.**

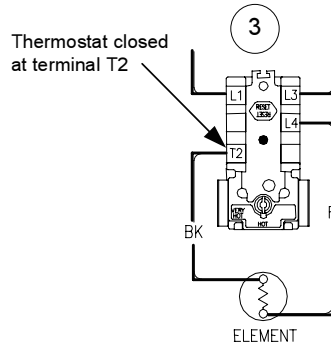
1 Line voltage is applied across terminals of fuse block or a terminal block. Line voltage continues down and connects to surface mounted thermostats at terminals L1 & L3.



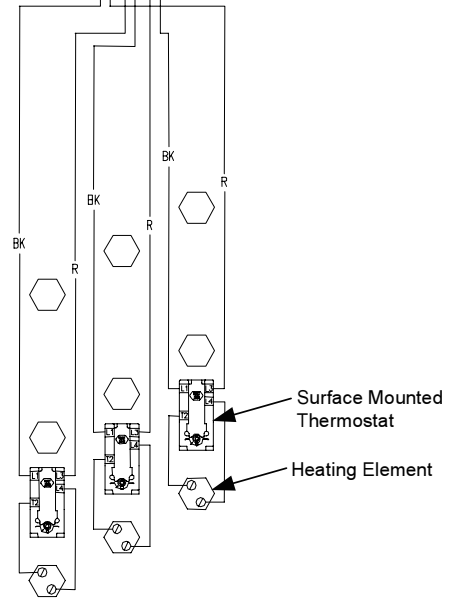
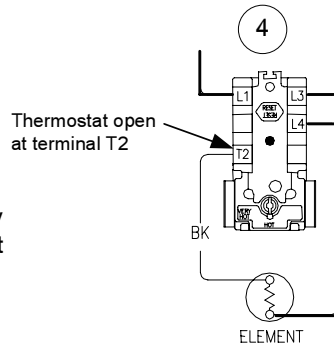
2 ECO (high limit) in thermostat is closed, so there is line voltage present at terminal L4 of thermostats and to one side of each element.



3 Water in tank is cold, so all thermostats are closed at terminal T2 (calling For heat). This completes the circuit and allows current to flow through heating elements.



4 As each thermostat is satisfied, it opens at terminal T2 interrupting current flow through the respective element. The system is now in stand-by mode, waiting for the next call for heat.



**Sequence of Operation:  
600V Surface Mounted Thermostats (w/Contactors).**

The system has two distinct circuits.

1. Power circuit - Line Voltage (600V)
2. Control Circuit - 120V

1 Line voltage is applied across terminals of fuse block or a terminal block. Line voltage continues down and connects to terminals L1, L2 & L3 of one or more contactors.

- A) Contactor is open (no call for heat), so there is no voltage across terminal T1, T2 & T3 of contactor.
- B) The contactor is controlled by the control circuit consisting of the surface mounted thermostat, ECO (hi limit) and contactor coil.

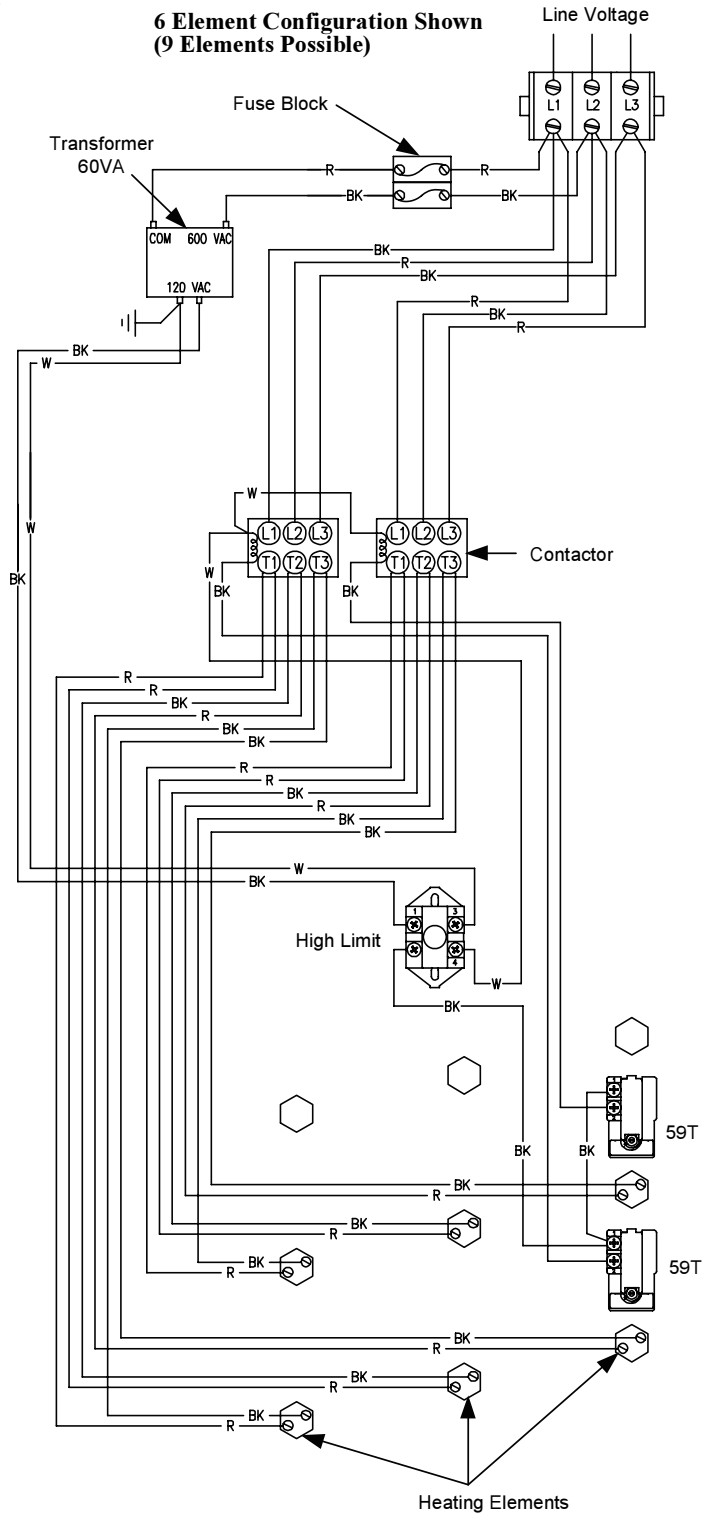
2 When the thermostat calls for heat, contacts close inside the thermostat completing the circuit through the ECO and energizing the contactor coil.

3 The energized contactor coil causes the contactor to close, energizing the elements from terminals T1, T2 & T3 of the contactor.

4 When the temperature setting of the thermostat is reached, the contacts in the thermostat open. This interrupts current flow through the control circuit de-energizing the contactor coil.

5 The de-energized contactor coil causes the contactor to open, interrupting current flow through the elements. The heater is now in stand-by waiting for the next call for heat.

6 Notice in the wiring diagram at right that each row of elements is equipped with a surface mounted thermostat on the highest element in the row. These thermostats are individually wired in series to the contactor whose line voltage corresponds to the same row of elements. Each thermostat and contactor combination are wired to the high limit (ECO) device in parallel. This allows for each row of elements to be powered "ON" independent of the other element rows. However, the high limit (ECO) is wired in series so that voltage can be interrupted to the entire control circuit if the ECO senses that the tank water has become overheated.



Most common cause for improper electric water heater operation can be linked to heating element failure.

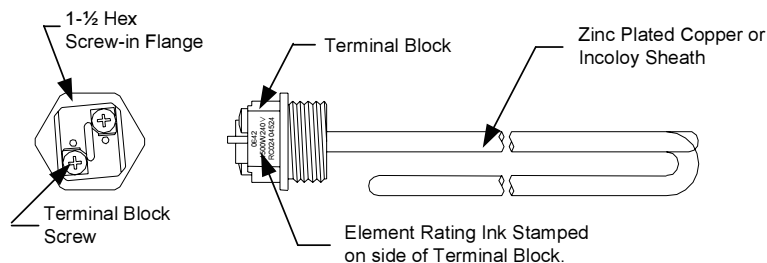
When troubleshooting an electric water heater with the incidence of “No Hot Water” or “Insufficient Amount of Hot Water” It is always a good idea to check the heating elements first following the procedure on page 15.

Common Heating Element Failures Are:

1. **Dry Firing.** Elements may be partially submerged in water or most likely, completely exposed with no water in the tank at all. In open air, an energized element (*Dry Fired*) will become completely inoperable within seconds. In some cases sediment or lime build up around an element can eventually cause an air pocket, resulting in a dry fired element. When element replacement is required, be sure tank is full of water prior to energizing the water heater.
2. **Grounded Element.** In most cases, an element with a short circuit to ground will cause the circuit breaker in the service panel to open or shut off. In some cases there may not be enough current draw for the circuit breaker to open. This will allow the heating element to be in continuous operation resulting in over heated water, limited only by the ECO or Energy Cut Off located in the thermostat circuit. Repeated actuation of the ECO usually is the result of a grounded heating element.
3. **Sediment build up.** Slow hot water recovery can usually be traced back to sediment or lime build up around heating element. Sediment build up can also over time cause a dry fired element.

If a heating element is found to be inoperative, it must be replaced. Follow service procedure MCE-XV on page 30.

The illustration below shows a common “Screw-In” type heating element identifying certain features commonly referred to throughout this manual.



**Typical Direct Immersion “Screw-In”  
Type Heating Element**



## Quick Step Plan to Hot Water

1. **STOP, DANGER! Turn power "OFF" to water heater.**
2. Check all wire connections to insure they are snug and corrosion free.
3. Reset high limit (ECO) (page 18-20).
4. Check for inoperative heating element (page 15).
5. Check line voltage (pg 16), and internal fuses (page 17).
6. Refer to table below if items 1 through 5 above do not correct problem.

**▲ WARNING**  
**High voltage exposure. Use caution when making voltage checks to avoid hazard to life or property.**

<b><u>SYMPTOM</u></b>	<b><u>PROBABLE CAUSE</u></b>	<b><u>CORRECTIVE ACTION</u></b>	<b><u>SERVICE PROCEDURE</u></b>
No Hot Water	<ol style="list-style-type: none"> <li>1. No power to heater.</li> <li>2. Blown water heater fuses.</li> <li>3. Loose wire connections.</li> <li>4. Inoperative heating elements.</li> <li>5. Inoperative thermostat(s).</li> <li>6. Open ECO.</li> <li>7. Inoperative contactor(s).</li> </ol>	<ol style="list-style-type: none"> <li>1. Check circuit breakers at service panel.</li> <li>2. Check water heater fuses.</li> <li>3. Check all wire connections.</li> <li>4. Check heating element(s).</li> <li>5. Check thermostat(s) operation.</li> <li>6. Reset (check) ECO.</li> <li>7. Check contactor operation.</li> </ol>	<ol style="list-style-type: none"> <li>2. MCE-III, Page 17</li> <li>4. MCE-I, Page 15.</li> <li>5. MCE-VII-IX, Page 21-23.</li> <li>6. MCE-IV-VI, Page 18-20.</li> <li>7. MCE-X, Page 24,25</li> </ol>
Not Enough Hot Water or Continues Operation	<ol style="list-style-type: none"> <li>1. Inoperative heating element.</li> <li>2. Sediment or lime build up on element(s).</li> <li>3. Thermostat(s) set to low.</li> <li>4. Inoperative thermostat(s).</li> <li>5. Inoperative contactor(s).</li> <li>6. Loose wire connection.</li> <li>7. High demand period.</li> <li>8. Undersized heater.</li> <li>9. Very cold inlet water to heater.</li> <li>10. Plumbing connections reversed.</li> </ol>	<ol style="list-style-type: none"> <li>1. Check heating element(s).</li> <li>2. Clean or replace heating element(s)</li> <li>3. Increase thermostat setting.</li> <li>4. Check thermostat(s).</li> <li>5. Check contactor operation.</li> <li>6. Check all wire connection.</li> <li>7. Reduce demand.</li> <li>8. Replace with larger heater.</li> <li>9. Temper water to heater.</li> <li>10. Correct plumbing connections.</li> </ol>	<ol style="list-style-type: none"> <li>1. MCE-I, Page 15.</li> <li>2. MCE-XV, Page 30.</li> <li>4. MCE-VII-IX, Page 21-23.</li> <li>5. MCE-X, Page 24,25</li> </ol>
Slow Hot Water Recovery	<ol style="list-style-type: none"> <li>1. Sediment or lime build up on element(s).</li> <li>2. Loose wire connections.</li> <li>3. Inoperative thermostat(s).</li> <li>4. Inoperative contactor(s).</li> <li>5. Derated heating element installed.</li> </ol>	<ol style="list-style-type: none"> <li>1. Clean or replace heating elements.</li> <li>2. Check all wire connections.</li> <li>3. Check thermostat(s).</li> <li>4. Check contactor operation.</li> <li>5. Verify element voltage and wattage rating.</li> </ol>	<ol style="list-style-type: none"> <li>1. MCE-XV, Page 30.</li> <li>3. MCE-VII-IX, Page 21-23.</li> <li>4. MCE-X, Page 24-25</li> <li>5. See page 8.</li> </ol>
Over Heated Water	<ol style="list-style-type: none"> <li>1. Surface thermostat(s) not flush with tank.</li> <li>2. Grounded heating element(s).</li> <li>3. Thermostat set to high.</li> <li>4. Inoperative thermostat(s).</li> <li>5. Inoperative ECO.</li> </ol>	<ol style="list-style-type: none"> <li>1. Check surface thermostat(s) mounting.</li> <li>2. Check heating element(s).</li> <li>3. Adjust thermostat(s) to desired setting.</li> <li>4. Check thermostat(s).</li> <li>5. Check ECO.</li> </ol>	<ol style="list-style-type: none"> <li>1. MCE-XI, Page 26.</li> <li>2. MCE-I, Page 15.</li> <li>4. MCE-VII-IX, Page 21-23.</li> <li>5. MCE-IV-VI, Page 18-20.</li> </ol>
Noisy (singing or hissing) Elements	<ol style="list-style-type: none"> <li>1. Lime formation on elements.</li> <li>2. High or low line voltage.</li> </ol>	<ol style="list-style-type: none"> <li>1. Clean or replace heating elements.</li> <li>2. Verify line voltage to heater.</li> </ol>	<ol style="list-style-type: none"> <li>1. MCE-XV, Page 30.</li> <li>2. MCE-II, Page 16.</li> </ol>
Noisy Contactor	<ol style="list-style-type: none"> <li>1. Low line voltage.</li> <li>2. Debris between contactor plates.</li> <li>3. Incorrect or defective operating coil.</li> <li>4. Loose wire connections.</li> </ol>	<ol style="list-style-type: none"> <li>1. Verify line voltage to heater</li> <li>2. Replace contactor.</li> <li>3. Replace contactor.</li> <li>4. Check wire connections.</li> </ol>	<ol style="list-style-type: none"> <li>1. MCE-II, Page 16</li> </ol>

**Test for Open or Burned Out Element.**

1. **STOP, DANGER! Turn power “OFF” to water heater.**
2. Remove access cover from lower control box.  
Remove insulation from inside of control box.
3. Disconnect wires from heating element.
4. Set multi-meter to “ohms” setting.
5. Touch probes of multi-meter to screw terminals of heating element (see illustration 1).
6. Reading should be 12.8 ohms (±6%) for a 240 volt, 4500 watt element, see table below for other elements.

$$\text{Ohms} = \frac{\text{Volts}^2}{\text{Watts}}$$

A reading outside the range using the formula above (±6%), indicates a bad element and the element must be replaced.

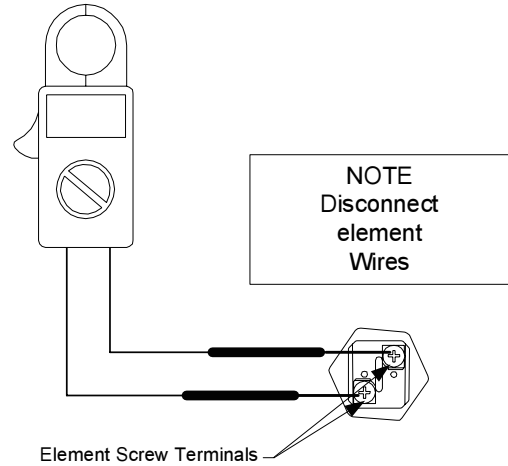
**Ohms of electrical Resistance  
For commonly Used Elements**

Element Wattage	<u>Voltage Rating of Element</u>		
	<u>208</u>	<u>240</u>	<u>480</u>
2000	21.6	28.8	115.2
3000	14.4	19.2	76.8
4000	10.8	14.4	57.6
4500	9.6	12.8	51.2
5000	8.7	11.5	46.1
6000	7.2	9.6	38.4

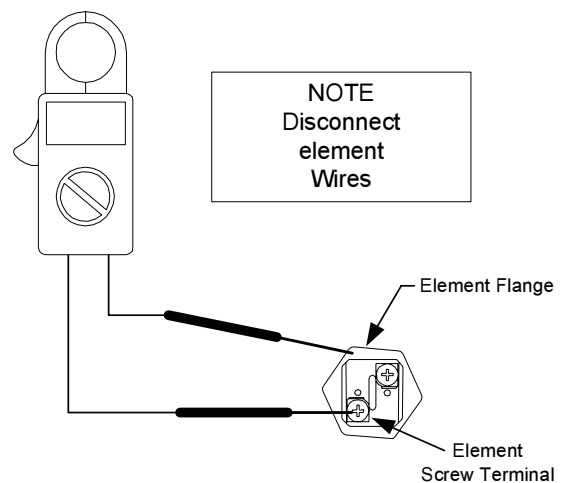
**Test For Grounded Heating Element  
(damaged heating element with short circuit to ground).**

1. **STOP, DANGER! Turn power “OFF” to water heater.**
2. Remove access cover from lower control box.  
Remove insulation from inside of control box.
3. Disconnect wires from heating element.
4. Set multi-meter to “ohms” setting.
5. Touch one probe of multi-meter to either screw terminal of heating element and the other on the element flange (see illustration 2). There should be no reading on the ohm meter. Any reading indicates a grounded element and the element must be replaced. Repeat this step for the other screw terminal.

**▲ DANGER**  
**High voltage exposure. To avoid hazard to  
Life or property, be sure power is turned OFF  
to water heater while performing this  
procedure.**



**Illustration 1**



**Illustration 2**

**Line Voltage Testing**

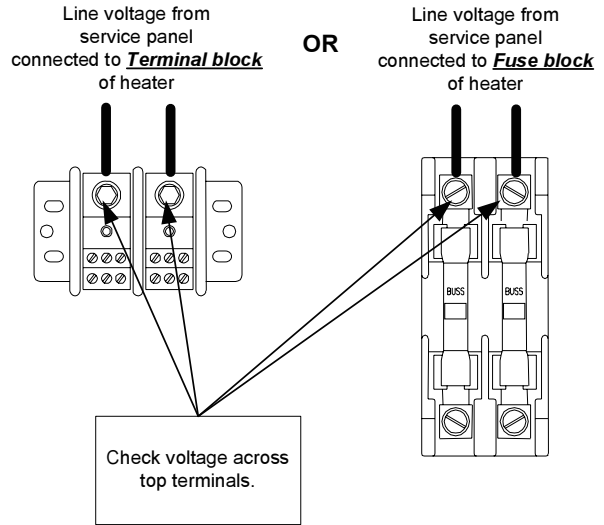
Line voltage (single phase or three phase) will connect to a terminal block or directly to a fuse block located inside control panel.

**⚠ DANGER**  
**High voltage exposure. To avoid hazard to life or property use extreme caution when making voltage checks .**

Determine heaters voltage and phase by referring to the rating plate located on the front of the heater. Apply the appropriate phase procedure below to determine if proper line voltage is present.

**Single Phase Line Voltage Testing**

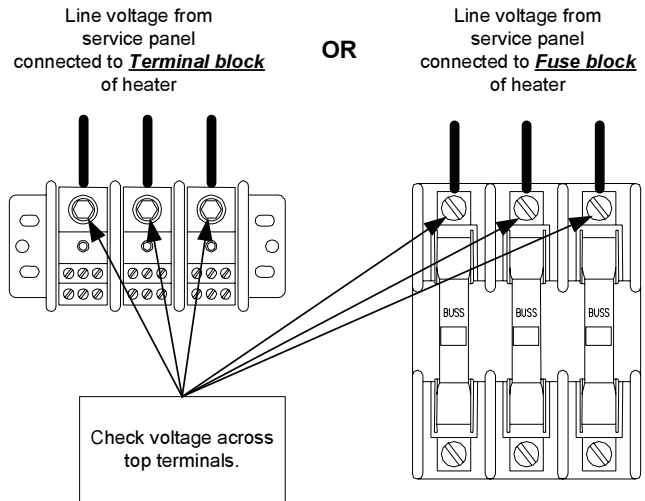
1. **STOP, DANGER! Turn power “OFF” to water heater.**
2. Open upper control panel door.
3. Determine connection point for line voltage from service panel, **terminal block** or **fuse block**
4. Set multi-meter to volts AC. Be sure to scale meter for appropriate voltage.
5. Use caution and turn power “ON” to water heater.
6. Use caution and check voltage across top terminals where service voltage connects to water heater. (see illustration 3).
  - A) Rated voltage IS present, power to the water heater is okay.
  - B) Rated voltage NOT present, Check service panel.



**Illustration 3**

**Three Phase Line Voltage Testing**

1. **STOP, DANGER! Turn power “OFF” to water heater.**
2. Open upper control panel door.
3. Determine connection point for line voltage from service panel, **terminal block** or **fuse block**
4. Set multi-meter to volts AC. Be sure to scale meter for appropriate voltage.
5. Use caution and turn power “ON” to water heater.
6. Use caution and check voltage across top terminals where service voltage connects to water heater. (see illustration 4).
  - A) Rated voltage IS present, power to the water heater is okay.
  - B) Rated voltage NOT present, Check service panel.

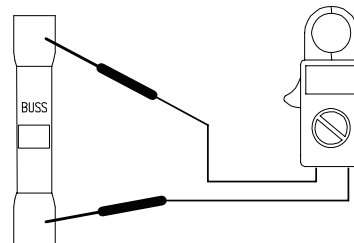


**Illustration 4**

**Fuse Testing**

1. Turn "OFF" power to water heater.
2. Open upper control box to allow access to fuse block.
3. Locate fuse block and remove fuses.
4. Set multi-meter to the "Ohms" setting.
5. Check continuity across fuse (see illustration 5).
  - A) Continuity IS present, fuse is okay.
  - B) Continuity NOT present, Replace with new fuse

**⚠ DANGER**  
High voltage exposure. To avoid hazard to Life or property, be sure power is turned OFF to water heater while performing this procedure.

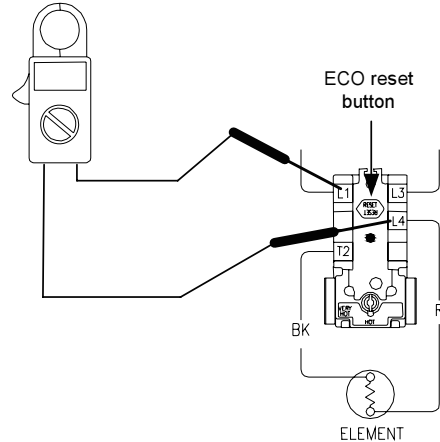


**Illustration 5**

**High Limit Control (ECO) Testing for  
Surface Thermostat models (not including 600V)**

**⚠ DANGER**  
**High voltage exposure. To avoid hazard to  
life or property use extreme caution when  
making voltage checks .**

1. This procedure assumes line voltage and fuses are in working order.
2. This procedure illustrates testing of just one surface thermostat. Repeat this procedure for all surface thermostats on the unit.
3. Turn power "OFF" to water heater.
4. Remove lower control box cover and remove insulation from inside of control box.
5. Remove plastic cover from thermostat(s).
6. Turn power "ON" to water heater.
7. Check voltage across terminals L1 & L4 for all thermostats (see illustration 6).



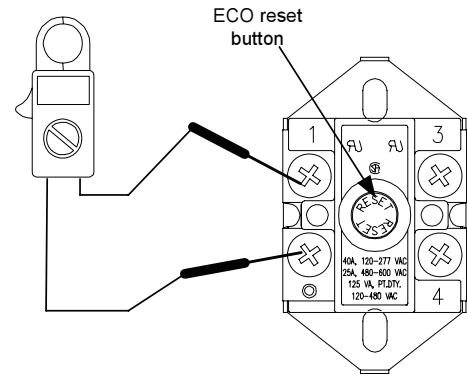
**Illustration 6**

- A) Rated Voltage IS present, ECO is okay.
  - B) Rated voltage NOT present, proceed to step 8.
8. Turn power "OFF" to water heater and firmly press ECO reset button on thermostat(s). Turn power "ON" to water heater and recheck voltage across terminals L1 & L4 of thermostat(s).
    - A) Rated voltage IS present, the ECO has previously opened indicating the water in the tank, at some point did overheat, Check the following:
      1. Thermostat must be in full contact with tank.
      2. Be sure heating element(s) is not shorted to ground (see page 15).
      3. Proper thermostat operation (see page 21).
    - B) Rated voltage NOT present, water in tank may be over heated.
      1. If water is overheated, turn "OFF" power to water heater and flow water through tank to cool below set point of upper thermostat. Reset ECO and recheck voltage.
      2. If water is cool, Replace thermostat(s).

**High Limit Control (ECO) Testing for  
600V Surface Thermostat Models**

1. This procedure assumes line voltage, transformer, fuses, and thermostat are in working order.
2. Turn power "OFF" to water heater.
3. Remove lower control box cover and remove insulation from inside of control box.
4. Check for continuity across terminals 1 & 2.  
(see illustration 7)
  - A) Continuity IS present, ECO is okay.
  - B) Continuity NOT present, proceed to step 5.
5. Verify power to the water heater is "OFF", firmly press the ECO reset button. Recheck continuity across terminals 1 & 2  
(see illustration 7).
  - A) Continuity IS present, the ECO has previously opened indicating the water in the tank, at some point did overheat, Check the following:
    1. Thermostat must be in full contact with tank.
    2. Be sure heating element(s) is not shorted to ground (see page 15).
    3. Proper thermostat operation (see page 22).
  - B) Continuity NOT present, water in tank may be over heated.
    1. If water is overheated, verify that power to water heater is "OFF". Flow water through the tank to cool below set point of upper thermostat. Reset ECO and recheck continuity.
    2. If water is cool, Replace ECO (High Limit).

**⚠ DANGER**  
High voltage exposure. To avoid hazard to life or property use extreme caution when making voltage checks .



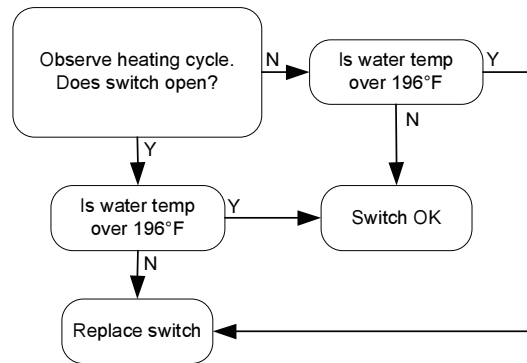
**Illustration 7**

**High Limit Control (ECO) Testing for  
Contactor Models**

**Switch Contacts:**

Normally closed.  
Open on rise @ 196°F ±4°F  
Manual Reset.

1. Determine if Hi-Limit has actuated. This can be done by simply depressing the reset buttons. If you hear and/or feel a small click, the switch has actuated.
2. Use caution and turn power on to water heater and observe heating cycle following the Hi-Limit Heating Cycle flow chart.

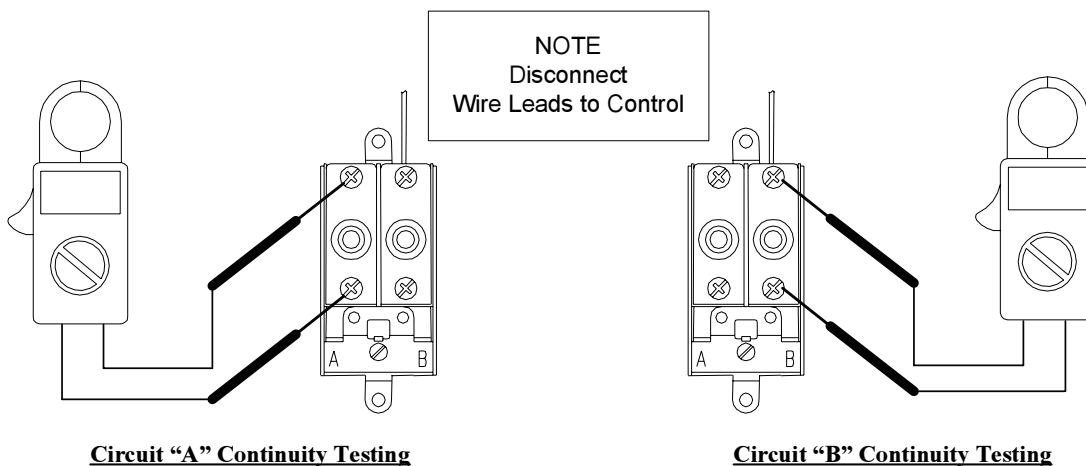


**High Limit Heating Cycle Flow Chart**

**High Limit Control Continuity Testing for  
Contactor Models**

1. **STOP, DANGER! Turn power “OFF” to water heater.**
2. Water temperature must be below 196°F ±4°F
3. Remove Hi-Limit switch from control panel. It is not necessary to remove immersion bulb from tank at this time. See general controls layout on page 4 for location.
4. Disconnect wire leads to Hi-Limit Control during this test.
5. Depress reset buttons to insure switch contacts are closed.
6. Set multi-meter to Ohms setting, Check continuity Thru circuit A & B as shown in the illustrations below.
  - Continuity **IS** present, Switch is okay.
  - Continuity **NOT** present, Replace switch.

**⚠ DANGER**  
High voltage exposure. To avoid hazard to Life or property, be sure power is turned OFF to water heater while performing this procedure.



**Surface Mounted Thermostat.**  
**Operation Testing (not including 600V models)**

**▲ DANGER**  
**High voltage exposure. To avoid hazard to life or property, use extreme caution when making voltage checks .**

**Water In Tank Is Cold With Power ON.**

1. This procedure assumes line voltage, ECO and elements are in working order.

**2. TURN OFF POWER TO WATER HEATER.**

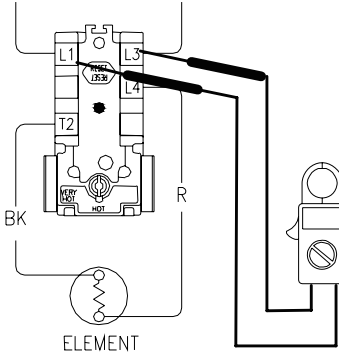
3. Remove access cover from lower control box. Remove insulation from inside of control box. Remove plastic cover from thermostat.

4. Turn power "ON" to water heater.

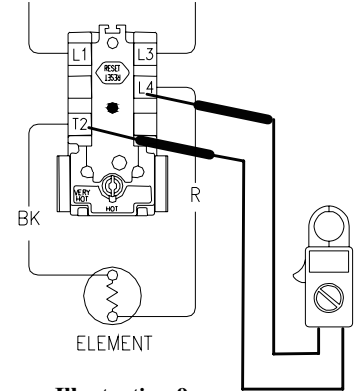
5. Set multi-meter to "Volts AC".

6. Check across terminals L1 & L3 of thermostat (see illustration 8)

- A) Rated voltage NOT present, Check fuses and or line voltage.
- B) Rated voltage IS present, proceed to next step.



**Illustration 8**



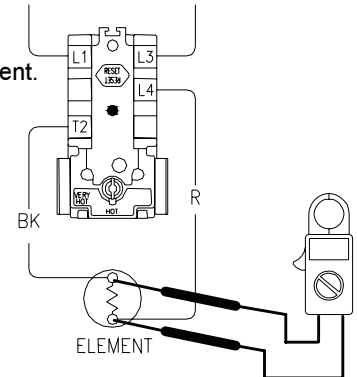
**Illustration 9**

7. Check across terminals L4 and T2 of thermostat (see illustration 9).

- A) Rated voltage NOT present, Recheck ECO. If ECO is okay, replace thermostat.
- B) Rated voltage IS present, okay, thermostat is calling for heat, go to next step.

8. Check across element terminals (see illustration 10).

- A) Rated voltage NOT present, check wire connections from thermostat to element.
- B) Rated voltage IS present, Repeat element testing, see page 15.



**Illustration 10**

**Water Temperature In Tank Is Above Thermostat Setting.**

1. This procedure assumes line voltage, ECO and elements are in working order.

2. Turn power "ON" to water heater.

3. Set multi-meter to "Volts AC".

4. See illustration 9 above, check across terminals L4 and T2 of thermostat.

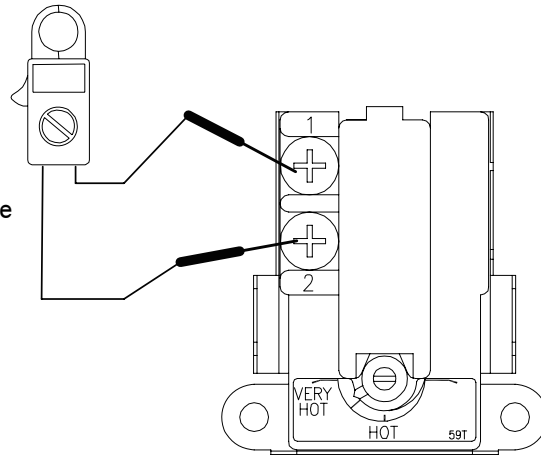
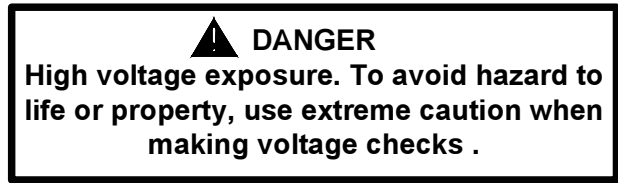
- A) Rated voltage IS present, replace thermostat.
- B) Rated voltage NOT present, thermostat is okay.
- C) Lower than rated voltage IS present, recheck for grounded element (see page 15).



**600V Surface Mounted Thermostat Models.  
Operation Testing**

**Water In Tank Is Cold With Power ON.**

1. This procedure assumes line voltage, ECO, transformer thermostat, and elements are in working order.
2. **TURN OFF POWER TO WATER HEATER.**
3. Remove access cover from lower control box.  
Remove insulation from inside of control box.
4. Using a phillips head screw driver, disconnect the wire lead at terminal 2 of the thermostat. Only check one thermostat at a time to insure wires are correctly reinstalled upon completion. Mark wires if necessary for reinstallation.
5. Set multi-meter to check continuity.
6. Check continuity across terminals 1 & 2 of thermostat (see illustration 11).
  - A) Continuity NOT present, replace thermostat.
  - B) Continuity IS present, thermostat is okay.



**Illustration 11**

**Water Temperature In Tank Is Above Thermostat Setting.**

1. This procedure assumes line voltage, ECO, thermostat, transformer, and elements are in working order.
2. **TURN OFF POWER TO WATER HEATER.**
3. Remove access cover from lower control box.  
Remove insulation from inside of control box.
4. Using a phillips head screw driver, disconnect the wire lead at terminal 2 of the thermostat. Only check one thermostat at a time to insure wires are correctly reinstalled upon completion. Mark wires if necessary for reinstallation.
5. Set multi-meter to check continuity.
6. See illustration 11 above, check across terminals 1 & 2 of thermostat.
  - A) Continuity IS present, replace thermostat.
  - B) Continuity NOT present, thermostat is okay.

**Immersion Thermostat Operation Testing**

**Thermostat Specification:**

Calibration: 184°F/176°F  
Max Differential: 6°F  
Operating Range 80 to 180°F

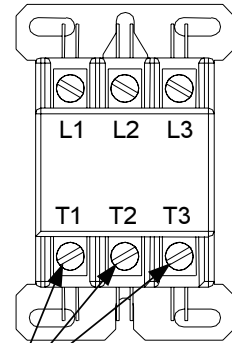
**▲ DANGER**  
**High voltage exposure. To avoid hazard to life or property use extreme caution when making voltage checks .**

Providing the water temperature in tank is within the operating range of the thermostat, checking thermostat operation can be as simple as rotating the thermostat dial and listening to the contactor(s) to see if they respond to a call for heat.

Use caution and turn Power “ON” and rotate the thermostat dial to call for heat. With water temperature below the thermostat setting, the contactor(s) close. With the contacts closed, use caution and check for rated voltage across lower terminals of contactor(s) (see illustration 12), If rated voltage is present, the thermostat is calling for heat.

Rotate thermostat dial to the minimum setting. With water temperature above the thermostat setting the contactor(s) will open. With the contacts open, voltage should not be present at lower terminals of contactor(s).

Follow the procedure below If preliminary testing above does not verify thermostat operation.



Check voltage across lower terminals of contactor(s) **Illustration 12**

**Thermostat Control Continuity Testing.**

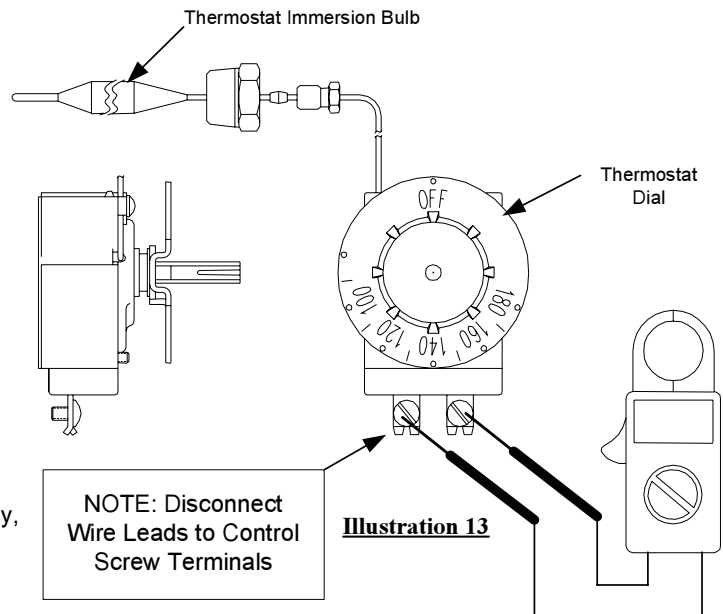
1. This procedure assumes line voltage, ECO and contactor(s) are in working order.
2. **STOP, DANGER! Turn power “OFF” to water heater.**
3. Remove lower control box cover and insulation.
4. Locate thermostat control (see general controls layout on page 4) and remove wire leads to control screw terminals.
5. Water temperature in tank must be within operating range of thermostat for this test. If above or below, it will be necessary to drain tank and remove thermostat immersion bulb from tank to warm or cool the bulb to be within operating range of thermostat.

6. Set multi-meter to the “Ohms” setting.
7. Rotate thermostat dial to highest setting.
8. Check across screw terminals of control (see illustration 13).

- A) Continuity IS present, okay, Go to step 9.
- B) Continuity NOT present, replace thermostat.

9. Rotate thermostat dial to lowest setting.
10. Check across screw terminals of control (see illustration 13).

- A) Continuity NOT present, thermostat is okay,
- B) Continuity IS present, replace thermostat.



**Contactor Operation Testing**

**▲ DANGER**  
**High voltage exposure. To avoid hazard to life or property, use extreme caution when making voltage checks .**

**Noisy Contactor**

Noisy or chattering contactor operation in most cases is due to voltage variations being supplied to the water heater. Extended periods of voltage variations will cause damage to the operating coil of the contactor causing noisy operation. Determine that service voltage to the unit meets the electrical requirements per the rating plate located on the front of the water heater.

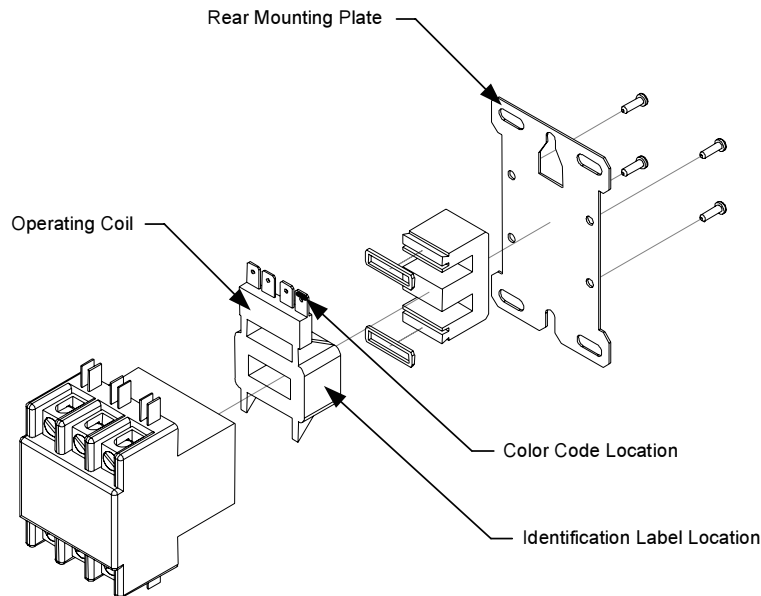
In addition, debris between the contact plates will cause noisy operation.

**Contactor Operating Coils**

Contactor operation is achieved by energizing an operating coil in response to a call for heat from the thermostat. There are three different operating coils used depending on voltage rating of the water heater as follows:

<u>Description</u>	<u>Color Code</u>
208/240 Volt Coil	Green
277 Volt Coil	Blue
480 Volt Coil	Black

All the coils have a color code for visual conformation. In addition, the 277 & 480 volt coils are labeled with voltage rating for proper identification. All contactors supplied for replacement are equipped with The 208/240 volt operating coil. By removing the rear mounting plate of the contactor, the operating coils can be changed based on desired service voltage. When contactor replacement is required be sure to order the proper operating coil base on the voltage rating found on the rating plate located on the front of the water heater.



**Contactor Operation Testing (continued)**

This procedure assumes control circuit is operating correctly.

Providing the water temperature in tank is within the operating range of the thermostat, checking contactor operation can be as simple as rotating the thermostat dial and listening to the contactor(s) to see if they respond to a call for heat.

1. Turn Power "ON" and rotate thermostat dial to the maximum setting, with water temperature in tank below the thermostat setting, the contactor(s) will close. With the contacts closed, check for line voltage across operating coil terminals (see illustration 14).

A) Line voltage IS present, okay, go to step 2.

B) Line voltage NOT present, verify control circuit operation.

2. Check for rated voltage across lower terminals of contactor(s) (see illustration 15).

A) Rated voltage IS present, okay, go to step 3.

B) Rated voltage NOT present, replace contactor.

3. Rotate thermostat dial to the minimum setting. With water temperature in tank above thermostat setting, the contactor(s) will open. With the contacts open, voltage should not be present at lower terminals of contactor(s).

4. Check for line voltage across operating coil terminals (see illustration 14).

A) Line voltage IS present, verify control circuit operation.

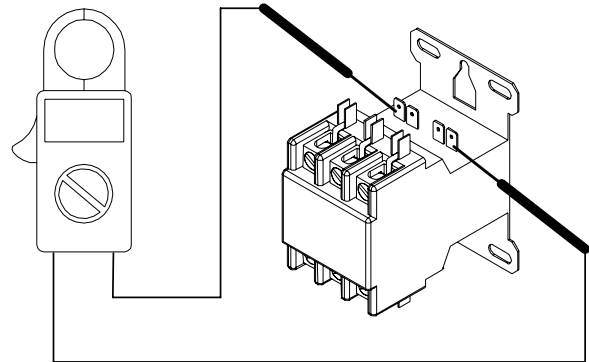
B) Line voltage NOT present, okay go to step 5.

5. Check for rated voltage across lower terminals of contactor(s) (see illustration 15).

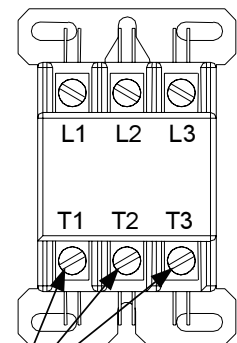
A) Rated voltage IS present, replace contactor.

B) Rated voltage NOT present, contactor is okay.

**▲ DANGER**  
**High voltage exposure. To avoid hazard to life or property, use extreme caution when making voltage checks .**



**Illustration 14**



Check voltage across lower terminals of contactor(s)

**Illustration 15**

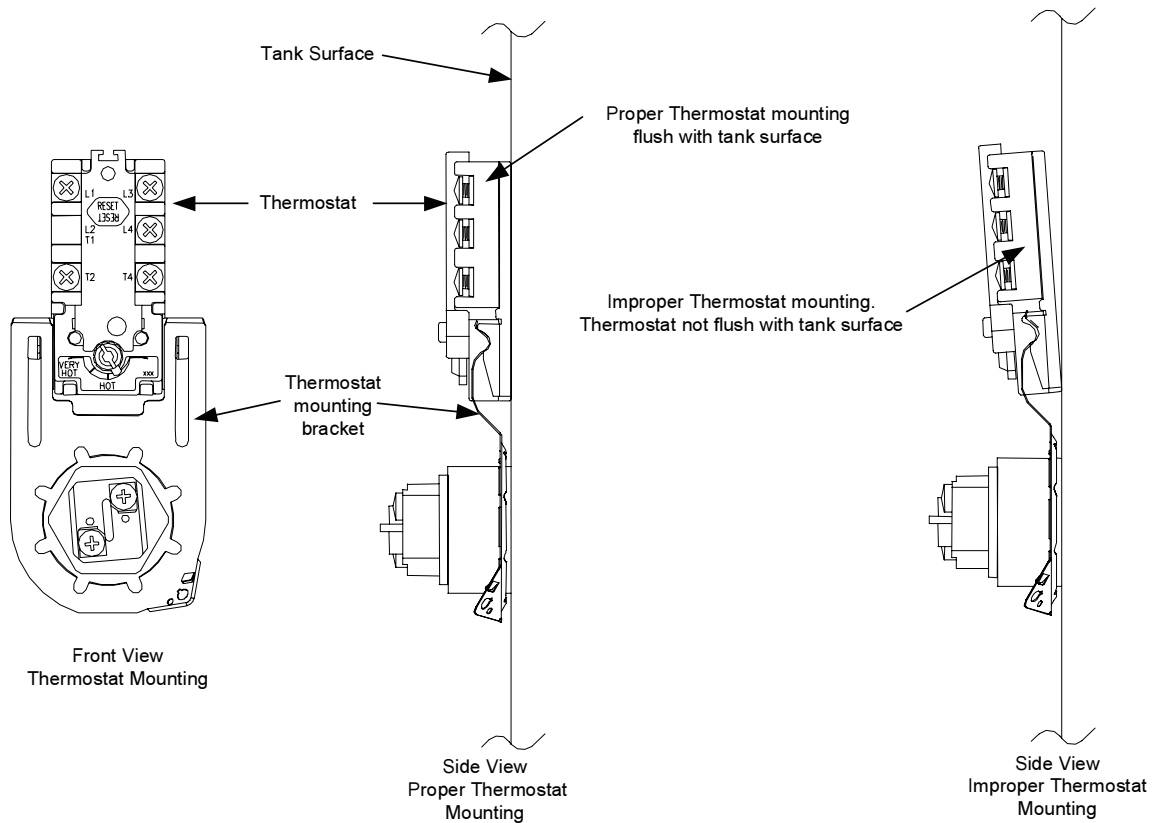
### Surface Mounted Thermostat Removal

1. **STOP, DANGER!** Turn power "OFF" to water heater.
2. Remove access cover from lower control box.  
Remove insulation from inside of control box.  
Remove plastic cover from thermostat.
3. Disconnect wires from thermostat terminals. It may be necessary to label wires for proper re-connection to new thermostat.
4. Note thermostat temperature setting for proper setting of new thermostat.
5. Slide thermostat upwards and out of mounting bracket.

**▲ DANGER**  
**High voltage exposure. To avoid hazard to Life or property, be sure power is turned OFF to water heater while performing this procedure.**

### Surface Mounted Thermostat Replacement

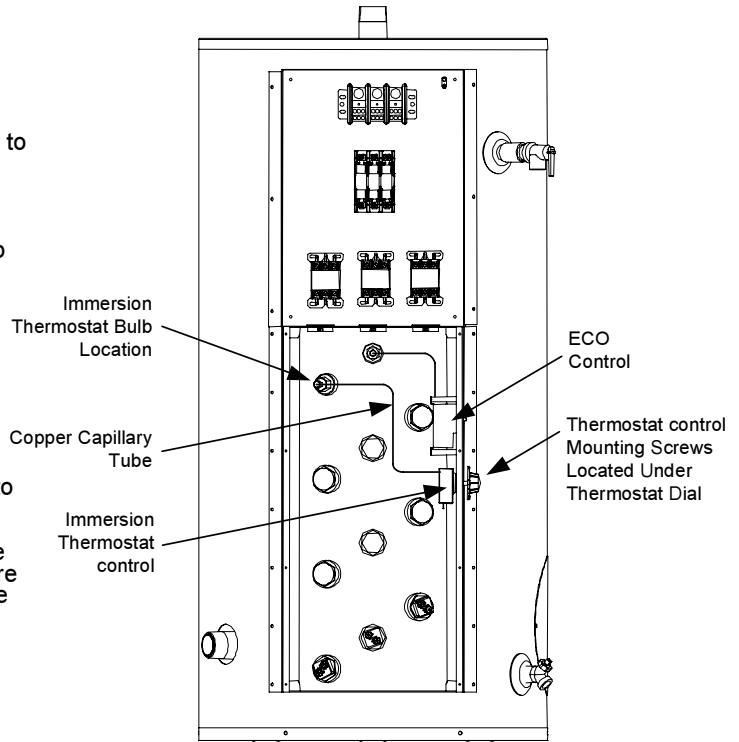
1. Use a stiff brush to remove any debris or loose scale from tank surface where new thermostat will be installed.
2. Slide new thermostat down into thermostat bracket until it snaps into place. **IMPORTANT!** Thermostat must set completely flat or flush to tank surface. An improperly installed thermostat will cause improper water heater operation.
3. Refer to the wire diagram located on the inside of the upper control box cover and re-connect wires to the thermostat. Be sure wire connections are snug and corrosion free. Do not over tighten, doing so may damage thermostat.
4. Set thermostat to the original thermostat setting found on the old thermostat.
5. Restore power to water heater and verify proper heater operation.



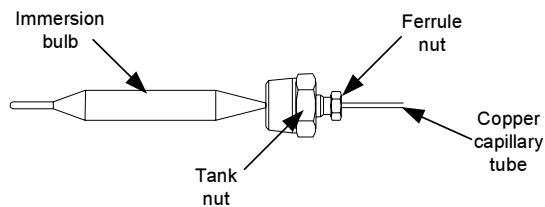
**Immersion Thermostat Removal & Replacement**

1. **STOP, DANGER!** Turn power “OFF” to water heater.
2. Turn off cold water supply to heater. Connect hose to drain spigot of water heater and route to an open drain. Open a nearby hot water faucet to vent heater for draining. Open drain spigot of water heater and allow heater to drain to a point below the Immersion bulb location (see illustration 16).
3. Close drain spigot and remove hose.
4. Remove lower control box cover and insulation.
5. Locate thermostat inside lower control box mounted to the right side of the box, below the ECO control (see illustration 16).
6. Follow copper capillary tube from thermostat to the immersion bulb location and remove immersion bulb from tank, 11/16 wrench.
7. Remove (pull) thermostat control dial from stem of thermostat.
8. Remove the two thermostat mounting screw screws located under thermostat dial (see illustration 16).
9. Once thermostat is removed, disconnect wire leads to the thermostat. **NOTE:** It may be necessary to identify wires for proper reconnection to new thermostat.
10. Refer to wiring diagram located on the inside of the upper control box cover and properly reconnect wire leads to new thermostat and remount control inside control box using screws from step 8.
11. Replace control dial to stem of thermostat.
12. Loosen ferrule nut of immersion bulb. (see illustration 17)

**▲ DANGER**  
**High voltage exposure. To avoid hazard to Life or property, be sure power is turned OFF to water heater while performing this procedure.**



**Illustration 16**



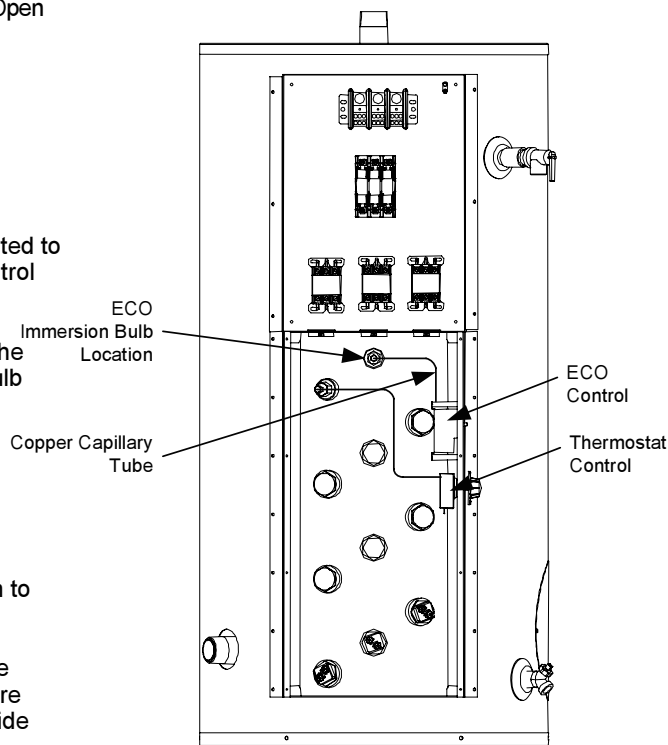
**Illustration 17**

13. Position tank nut at end of immersion bulb as shown in illustration 17. Insert immersion bulb into tank and tighten tank nut.
14. Gently pull copper capillary tube to insure the immersion bulb is in a horizontal position as shown in illustration 17 and tighten ferrule nut.
15. Resume water supply, fill tank and check for leaks.
16. Be sure tank is full of water and resume power supply to water heater. Verify proper thermostat operation.

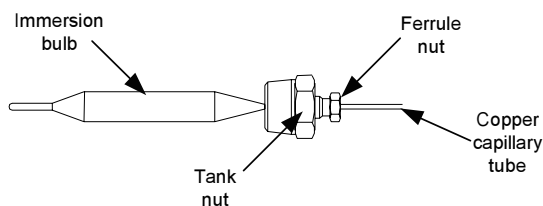
**Contactactor Model High Limit (ECO) Control  
 Removal and Replacement**

1. **STOP, DANGER!** Turn power “OFF” to water heater.
2. Turn off cold water supply to heater. Connect hose to drain spigot of water heater and route to an open drain. Open a nearby hot water faucet to vent heater for draining. Open drain spigot of water heater and allow heater to drain to a point below the Immersion bulb location (see illustration 18).
3. Close drain spigot and remove hose.
4. Remove lower control box cover and insulation.
5. Locate ECO control inside lower control box mounted to the right side of the box, above the thermostat control (see illustration 18).
6. Follow copper capillary tube from ECO control to the immersion bulb location and remove immersion bulb from tank, 11/16 wrench.
7. Remove the two ECO control mounting screws located outside the lower control box.
8. Once ECO control is removed, disconnect wire leads to the control. NOTE: It may be necessary to identify wires for proper reconnection to new control.
9. Refer to wiring diagram located on the inside of the upper control box cover and properly reconnect wire leads to new ECO control and remount control inside control box using screws from step 7.
10. Loosen ferrule nut of immersion bulb. (see illustration 19)

**▲ DANGER**  
**High voltage exposure. To avoid hazard to  
 Life or property, be sure power is turned  
 OFF to water heater while performing this  
 procedure.**



**Illustration 18**



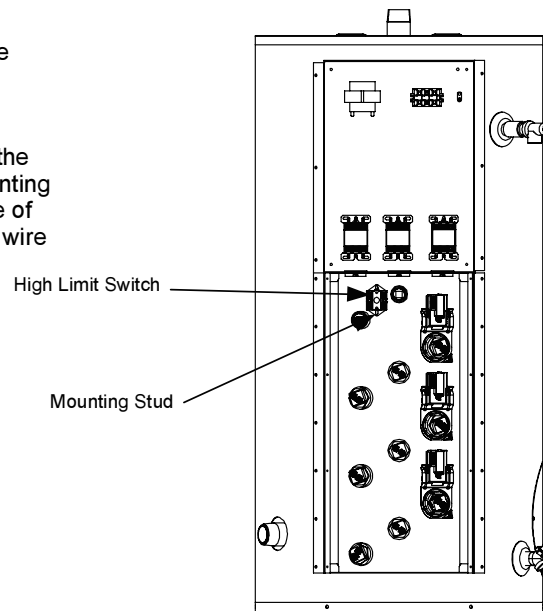
**Illustration 19**

11. Position tank nut at end of immersion bulb as shown in illustration 19. Insert immersion bulb into tank and tighten tank nut.
12. Gently pull copper capillary tube to insure the immersion bulb is in a horizontal position as shown in illustration 19 and tighten ferrule nut.
13. Resume water supply, fill tank and check for leaks.
14. Be sure tank is full of water and resume power supply to water heater. Verify proper ECO operation.

**600V Surface Thermostat Model**  
**High Limit (ECO) Control**  
**Removal and Replacement**

1. STOP, DANGER! Turn power "OFF" to water heater.
2. Remove lower control box cover and insulation.
3. Locate high limit switch mounted to the tank above the element spuds (see illustration 20).
4. Disconnect wire leads to the high limit. NOTE: It may be necessary to identify wires for proper reconnection to new control.
5. Remove the two high limit mounting nuts holding the sensor to the tank. Take care not to damage the mounting studs.
6. Fasten the replacement high limit to the tank using the nuts from step 5. Take care not to damage the mounting studs. Refer to wiring diagram located on the inside of the upper control box cover and properly reconnect wire leads to new high limit.
7. Verify proper ECO operation.

**▲ DANGER**  
**High voltage exposure. To avoid hazard to Life or property, be sure power is turned OFF to water heater while performing this procedure.**



**Illustration 20**



**Heating Element Removal**

1. **STOP, DANGER!** Turn power "OFF" to water heater.
2. Turn off cold water supply to heater. Connect hose to drain spigot of water heater and route to an open drain. Open a nearby hot water faucet to vent heater for draining. Open drain spigot of water heater and allow heater to drain to a point below the Element(s).
3. Close drain spigot and remove hose.
4. Remove access cover from lower control box. Remove insulation from inside of control box. Remove plastic cover from thermostat.
5. Disconnect wires from element terminals.
6. Remove element from tank using 1-1/2" deep well socket or appropriate wrench. Unscrew element counter-clockwise to remove from tank.
7. Be sure to remove old element gasket from the tank. It is not recommended to be re-used.

**▲ DANGER**

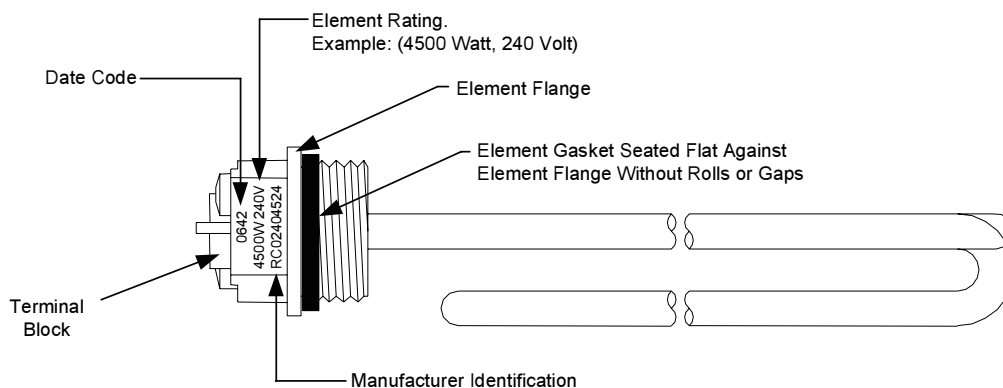
**High voltage exposure. To avoid hazard to Life or property, be sure power is turned OFF to water heater while performing this procedure.**

**▲ WARNING**

**Heater components and stored water may be HOT when performing the following steps in this procedure. Take necessary precaution to prevent personal injury.**

**Heating Element Replacement**

1. Check new element terminal block for proper electrical rating. NOTE: Some elements have dual ratings, be sure to check all surfaces of the element terminal block (see illustration below).
2. Apply new element gasket to the new element. Be sure gasket is seated flat against element flange without rolls or gaps (see illustration below).
3. Clean any debris from element fitting on tank.
4. Thread new element clockwise into tank. Tighten element using 1-1/2" deep well socket or appropriate wrench. Do not over tighten, over tightening may damage element gasket.
5. Reconnect wires to element, be sure connections are snug and corrosion free. Do not over tighten, doing so may damage terminal block.
6. Resume water supply to heater, be sure tank is full of water and check for leaks.
7. Re-install plastic thermostat protector(s).
8. Re-install insulation and control box cover.
9. To resume operation, **BE SURE TANK IS FULL OF WATER** and restore power to water heater. Verify proper heater operation.

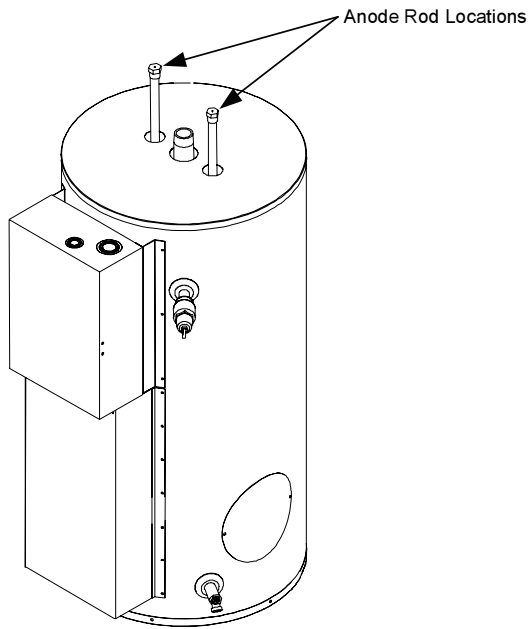


Anode Inspection and Replacement

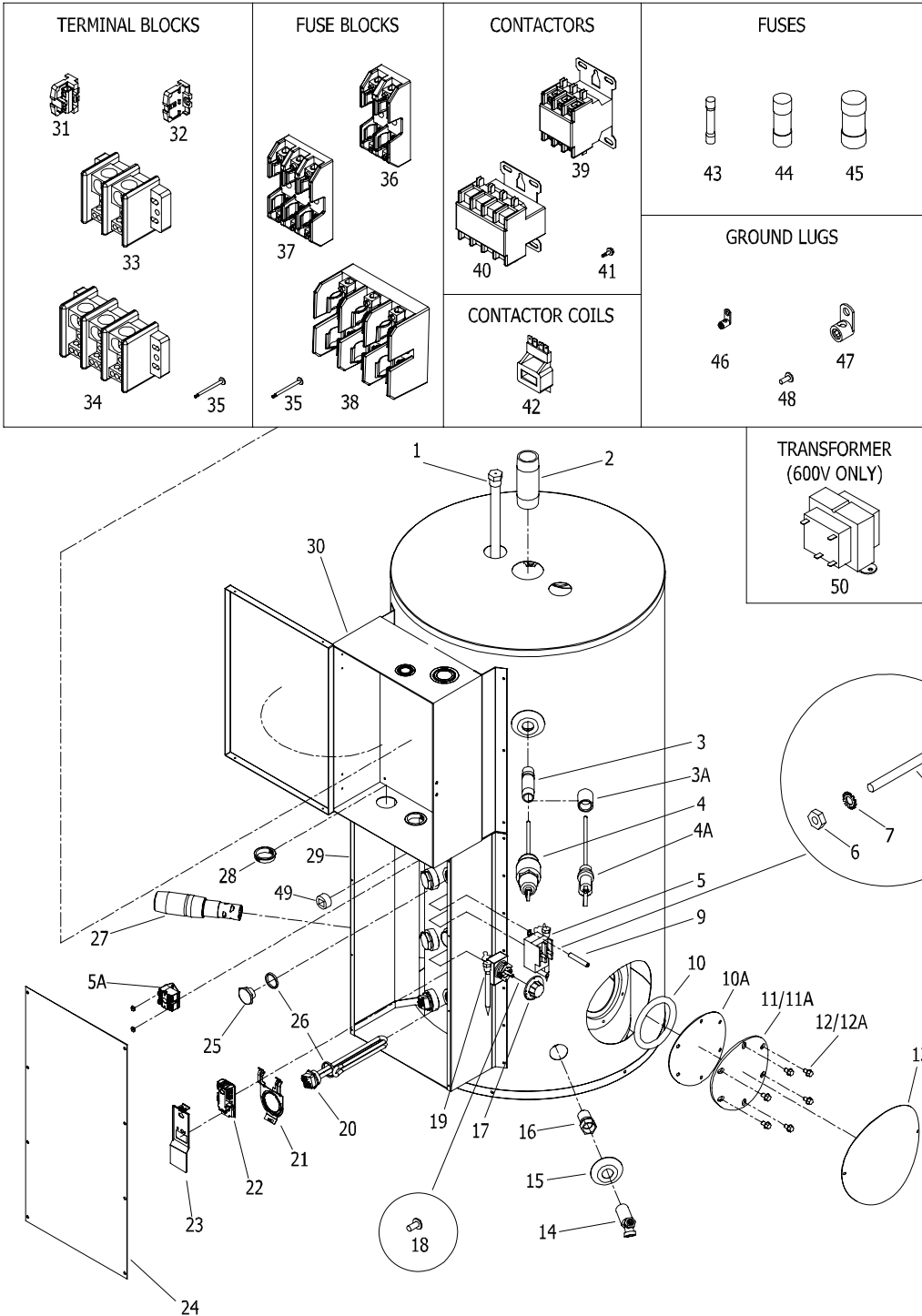
**▲ DANGER**  
High voltage exposure. To avoid hazard to Life or property, be sure power is turned OFF to water heater while performing this procedure.

**▲ WARNING**  
Heater components and stored water may be HOT when performing the following steps in this procedure. Take necessary precaution to prevent personal injury.

1. Turn power "OFF" to water heater.
2. Turn off cold water supply to heater. Connect hose to drain spigot of water heater and route to an open drain. Open a nearby hot water faucet to vent heater for draining. Open drain spigot of water heater and allow heater to drain to a point below the anode locations at the top of the tank.
3. Close drain spigot and remove hose.
4. Remove the plastic anode access plugs at the anode locations.
5. Remove anode from the water heater (1-1/16" socket).
6. Visually inspect anode. Anode should show signs of depletion, this is normal. If depletion is 1/2 of the original anode diameter (original diameter approximately 3/4"), replacement is recommended. If any of the steel core of the anode is exposed, replacement is recommended.
7. Upon completion of inspection or subsequent replacement, reinstall anode into heater. resume water supply, refill heater with water and check for leaks.
8. To resume operation, **BE SURE HEATER IS FULL OF WATER** and turn power "ON" to water heater.



# Generic Parts List



<u>Item</u>	<u>Description</u>	<u>Item</u>	<u>Description</u>
1	Anode.	26	Heating Element Gasket.
2	Hot Water Outlet Nipple.	27	Cold Water Inlet Nipple.
3	T&P Nipple.	28	Plastic Snap Bushing.
3A	T&P Coupling.	29	Lower Control Box.
4	T&P Relief Valve.	30	Upper Control Box.
5	High Limit Switch.	31	Terminal Block (Block A)
5A	Surface High Limit Switch.	32	Terminal Block End (used for block A).
6	Hex Nut	33	Terminal Block 2 pole.
7	Lock Washer	34	Terminal Block 3 Pole.
8	Screw	35	Screw.
9	High Limit Spacer.	36	Fuse Block 2 Pole Class G
10	Cleanout O-Ring.	37	Fuse Block 3 Pole Class G
10A	Cleanout Gasket (ASME).	38	Fuse Block 3 Pole Class J
11	Cleanout Cover.	39	Contactor 3 Pole.
11A	Cleanout Cover (ASME).	40	Contactor 4 Pole.
12	Cleanout Cover Screw.	41	Screw.
12A	Cleanout Cover Screw (ASME)	42	Contactor Coil
13	Cleanout Access Cover.	43	Fuse Class G
14	Brass Drain Valve.	44	Fuse Class J
15	Escutcheon.	45	Fuse Class J
16	Drain Extender.	46	Ground Lug Small.
17	Thermostat Dial	47	Ground Lug Large.
18	Screw.	48	Screw.
19	Immersion Thermostat.	49	¾ NPT Plug.
20	Heating Element.	50	Transformer - 120V
21	Surface thermostat Bracket.		
22	Surface Thermostat.		
23	Surface Thermostat Cover.		
24	Lower Control Box Cover.		
25	Heating Element Plug.		

**Glossary of Terms**

<u>Term</u>	<u>Definition</u>	<u>Unit of measure</u>
Voltage -	Electrical potential	Volts
Current-	Rate of voltage flow	Amperes (amp)
Resistance-	Ability of a device to dissipate power irreversibly	Ohms
Energy-	Ability to do work	kW/hr, Joule
Power-	Energy per unit of time	Watts, kW, VA

One kilowatt (1kW) = 1,000 Watts. = 3,412 BTU

DC = Direct Current

AC = Alternating Current

Hz = Hertz

°F = Degrees Fahrenheit

°C = Degree Centigrade

BTUH = British thermal units per hour

PSI = Pounds per square inch

GPM = Gallons per minute

GPH = Gallons per hour

ECO = Energy cut off

NPT = National pipe thread

ASME = American Society of Mechanical Engineers







# **BRADFORD WHITE®**

W A T E R H E A T E R S

Ambler, PA

For U.S. and Canada field service,  
contact your professional installer or  
local Bradford White sales representative.

**Sales/800-523-2931**  
**Fax/215-641-1670**  
**Parts Fax/215-641-2180**

**Technical Support/800-334-3393**  
**Fax/269-795-1089**

**Warranty/800-531-2111**  
**Fax/269-795-1089**

**International:**  
**Telephone/215-641-9400**  
**Telefax/215-641-9750**



# **BRADFORD WHITE-CANADA® INC.**

Mississauga, ON

**Sales/866-690-0961**  
**905-238-0100**

**Fax/905-238-0105**

**Technical Support/800-334-3393**

**Email**

**parts@bradfordwhite.com**  
**techserv@bradfordwhite.com**

**www.bradfordwhite.com**