

LIGHT DUTY COMMERCIAL ELECTRIC WATER HEATER

A Spanish language version of these instructions is available by contacting the company listed on the rating plate.

La versión española de estas instrucciones se puede obtener al escribirle a la fábrica cuyo nombre aparece en la placa de especificaciones.

INSTALLATION & OPERATING INSTRUCTION MANUAL

THE WARRANTY ON THIS WATER HEATER IS IN EFFECT ONLY WHEN THE WATER HEATER IS INSTALLED AND OPERATED IN ACCORDANCE WITH LOCAL CODES AND THESE INSTRUCTIONS. THE MANUFACTURER OF THIS HEATER WILL NOT BE LIABLE FOR ANY DAMAGE RESULTING FROM FAILURE TO COMPLY WITH THESE INSTRUCTIONS. READ THESE INSTRUCTIONS THOROUGHLY BEFORE STARTING.

For safety and convenience, it is recommended that this water heater be installed and serviced by a plumbing professional.

TABLE OF CONTENTS

General Information	3
Installation	4
Locating The Water Heater	4
Water Connections.....	5
Electrical Connections.....	10
General Operation	16
Thermostat Adjustment	17
Maintenance.....	18

CONGRATULATIONS!

You have just purchased one of the finest water heaters on the market today!

This installation, operation and instruction manual will explain in detail the installation and maintenance of your new Light Duty Commercial Electric Water Heater. We strongly recommend that you contact a plumbing professional for the installation of this water heater.

We require that you carefully read this manual, as well as the enclosed warranty, and refer to it when questions arise. If you have any specific questions concerning your warranty, please consult the plumbing professional from whom your water heater was purchased. For your records we recommend that you write the model, serial number and installation date of your water heater in the maintenance section in the back of this manual.

This manual should be kept with the water heater.

GENERAL INFORMATION

This electric water heater's design is certified by Underwriters Laboratories (UL) and listed in accordance with UL 174. C-UL listed in accordance with Canadian National Standard C22.2, No. 110-M90.

This water heater must be installed in accordance with local codes. In the absence of local codes, install this water heater in accordance with the N.E.C. Reference Book (latest edition).

The warranty for this water heater is in effect only when the water heater is installed, adjusted, and operated in accordance with these Installation and Operating Instructions. The manufacturer will not be held liable for damage resulting from alteration and/or failure to comply with these instructions.

To comply with NSF requirements this water heater is to be:

- a) Sealed to the floor with sealant, in a smooth and easily cleanable way, or
- b) Installed with an optional leg kit that includes legs and/or extensions that provide a minimum clearance of 6" beneath the water heater.

This water heater has been designed and certified for the purpose of heating potable water. The installation and use of this water heater for any purpose other than the heating of potable water, may cause damage to the water heater and create a hazardous condition and nullify the warranty.

CAUTION

Incorrect operation of this appliance may create a hazard to life and property and will nullify the warranty.

Do not use this appliance if any part has been submerged in water. The plumbing professional responsible for the installation of this water heater should be contacted to inspect the appliance and to replace any part of the control system, including thermostat, which has been submerged in water.

Make sure that the rating plate on the water heater is referenced for certainty that the correct voltage is being supplied to the water heater.

DANGER

Do not store or use gasoline or other flammable, combustible, or corrosive vapors and liquids in the vicinity of this or any other appliance.

A sacrificial anode is used to extend tank life. Removal of this anode for any reason will nullify the warranty. In areas where water is unusually active, an odor may occur at the hot water faucet due to a reaction between the sacrificial anode and impurities in the water. If this should happen, an alternative anode may be purchased from the supplier that installed this water heater. This will minimize the odor while protecting the tank. Additionally, the water heater should be flushed with appropriate dissolvers to eliminate any bacteria.

IMPORTANT

Before proceeding, please inspect the water heater and its components for possible damage. DO NOT install any damaged components. If damage is evident, please contact the supplier where the water heater was purchased or the manufacturer listed on the rating plate for replacement parts.

INSTALLATION

Locating The Water Heater

WARNING

Water heaters are heat producing appliances. To avoid damage or injury, there shall be no materials stored against the water heater and proper care shall be taken to avoid unnecessary contact (especially by children) with the water heater. **UNDER NO CIRCUMSTANCES SHALL FLAMMABLE MATERIALS, SUCH AS GASOLINE OR PAINT THINNER BE USED OR STORED IN THE VICINITY OF THIS WATER HEATER OR ANY LOCATION FROM WHICH FUMES COULD REACH THE WATER HEATER.**

This water heater MUST be installed indoors out of the wind and weather.

This water heater shall NOT be installed in any location where gasoline or flammable vapors are likely to be present, unless the installation is such to eliminate the probable ignition of gasoline or flammable vapors.

The location this water heater is to be installed is of utmost importance. Before installing this water heater, consult the installation section of these instructions. After reading these installation and operating instructions, select a location for the water heater where the floor is level and is easily accessible to a power supply and water connections. It is recommended that the water heater be located near the center of greatest hot water usage to prevent heat loss through the pipes. **DO NOT locate the water heater where water lines could be subjected to freezing temperatures. Locate the water heater so that access panels and drain valves are accessible.** Some models are not equipped with a drain valve. For those models, install a drain tee in the cold water inlet as close as practical to the water heater.

Water heater corrosion and component failure can be caused by the heating and breakdown of airborne chemical vapors. Examples of some typical compounds that are potentially corrosive are: spray can propellants, cleaning solvents, refrigerator and air conditioning refrigerants, swimming pool chemicals, calcium or sodium chloride, waxes and process chemicals.

Locating the Water Heater continued-

These materials are corrosive at very low concentration levels with little or no odor to reveal their presence. **NOTE: DAMAGE TO THE WATER HEATER CAUSED BY EXPOSURE TO CORROSIVE VAPORS IS NOT COVERED BY THE WARRANTY. DO NOT OPERATE THE WATER HEATER IF EXPOSURE HAS OR WILL OCCUR. DO NOT STORE ANY POTENTIALLY CORROSIVE COMPOUNDS IN THE VICINITY OF THE WATER HEATER.**

This water heater must be located in an area where leakage of the tank or water line connections and the combination temperature and pressure relief valve will not result in damage to the area adjacent to the water heater or to lower floors of the structure. When such locations cannot be avoided, a suitable drain pan must be installed under the water heater. The drain pan must have a minimum length and width of at least 4 in. (10.2 cm) greater than the diameter of the water heater. The drain pan, as described above, can be purchased from your plumbing professional. The drain pan must be piped to an adequate drain. The piping must be pitched for proper drainage.

Note: For California installation this water heater must be braced, anchored, or strapped to avoid falling or moving during an earthquake. See instructions for correct installation procedures. Instructions may be obtained from the DSA Headquarters Office, 1102 Q Street, Suite 5100, Sacramento, CA 95811.

Water Connections

NOTE: BEFORE PROCEEDING WITH THE INSTALLATION, CLOSE THE MAIN WATER SUPPLY VALVE.

After shutting the main water supply valve, open a faucet to relieve the water line pressure to prevent any water from leaking out of the pipes while making the water connections to the water heater. After the pressure has been relieved, close the faucet. The COLD water inlet and HOT water outlet are identified on top of the water heater. The fittings at the cold water inlet and hot water outlet are dielectric waterway fittings with 3/4" NPT tapered male threads. Make the proper plumbing connections between the water heater and the plumbing system in the house. Install a shut-off valve in the cold water supply line.

CAUTION

If sweat fittings are to be used, **DO NOT** apply heat to the nipples on top of the water heater. Sweat the tubing to the adapter before fitting the adapter to the water connections. It is imperative that heat is not applied to the nipples containing a plastic liner.

IMPORTANT

FAILURE TO INSTALL AND MAINTAIN A NEW, LISTED 3/4" X 3/4" TEMPERATURE-PRESSURE RELIEF VALVE WILL RELEASE THE MANUFACTURER FROM ANY CLAIM WHICH MIGHT RESULT FROM EXCESSIVE TEMPERATURE AND PRESSURES.

If this water heater is installed in a closed water supply system, such as the one having a back-flow preventer in the cold water supply, provisions shall be made to control thermal expansion. DO NOT operate this water heater in a closed system without provisions for controlling thermal expansion. Your water supplier or local plumbing inspector should be contacted on how to control this situation.

After installation of the water lines, open the main water supply valve and fill the water heater. While the water heater is filling, open several hot water faucets to allow air to escape from the water system. When a steady stream of water flows through the faucets, close them and check all water connections for possible leaks. **NEVER OPERATE THE WATER HEATER WITHOUT FIRST BEING CERTAIN IT IS FILLED WITH WATER.**

▲ WARNING

Hydrogen gas can be produced in a hot water system served by this water heater that has not been used for a long period of time (generally two weeks or more). Hydrogen gas is extremely flammable. To reduce the risk of injury under these conditions, it is recommended that the hot water faucet be opened for several minutes at the kitchen sink before using any electrical appliance connected to the hot water system. If hydrogen is present, there will probably be an unusual sound such as air escaping through the pipe as the water begins to flow. There should be no smoking or open flame near the faucet at the time it is open.

⚠ WARNING

For protection against excessive temperatures and pressure, install temperature and pressure protective equipment required by local codes, but not less than a combination temperature and pressure relief valve certified by a nationally recognized testing laboratory that maintains periodic inspection of production of listed equipment or materials, as meeting the Requirements for *Relief Valves and Automatic Gas Shutoff Devices for Hot Water Supply Systems, ANSI Z21.22*, and the Standard *CAN1-4.4 Temperature, Pressure, Temperature and Pressure Relief Valves and Vacuum Relief Valves*. The combination temperature and pressure relief valve shall be marked with a maximum set pressure, not to exceed the maximum working pressure of the water heater. The combination temperature and pressure relief valve shall also have an hourly rated temperature steam BTU discharge capacity not less than the hourly input rating of the water heater.

Install the combination temperature and pressure relief valve into the opening provided and marked for this purpose on the water heater

Note: Some models may already be equipped or supplied with a combination temperature and pressure relief valve. Verify that the combination temperature and pressure relief valve complies with local codes. If the combination temperature and pressure relief valve does not comply with local codes, replace it with one that does. Follow the installation instructions above on this page.

Install a discharge line so that water discharged from the combination temperature and pressure relief valve will exit within six (6) inches (15.3 cm) above, or any distance below the structural floor and cannot contact any live electrical part. The discharge line is to be installed to allow for complete drainage of both the temperature and pressure relief valve and the discharge line. The discharge opening must not be subjected to blockage or freezing. **DO NOT** thread, plug or cap the discharge line. It is recommended that a minimum of four (4) inches (10.2 cm) be provided on the side of the water heater for servicing and maintenance of the combination temperature and pressure relief valve.

Do not place a valve between the combination temperature and pressure relief valve and the tank.

⚠ CAUTION

INCREASING THE THERMOSTAT SETTING ABOVE THE PRESET TEMPERATURE MAY CAUSE SEVERE BURNS AND CONSUME EXCESSIVE ENERGY. HOTTER WATER INCREASES THE RISK OF SCALD INJURY.

This water heater can deliver scalding temperature water at any faucet in the system. Be careful whenever using hot water to avoid scalding injury. Certain appliances, such as dishwashers and automatic clothes washers, may require increased temperature water. By setting the thermostat on this water heater to obtain increased temperature water required by these appliances, you may create the potential for scald injury. To protect against injury, you should install an ASSE approved mixing valve in the water system. This valve will reduce point of discharge temperature by mixing cold and hot water in branch supply lines. Such valves are available from the manufacturer listed on the rating plate or from your local plumbing supplier. Please consult with a plumbing professional.

⚠ DANGER

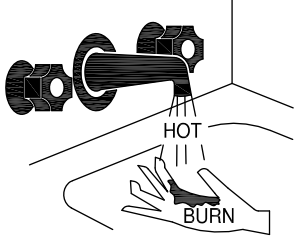

Water temperature over 125°F (52°C) can cause severe burns instantly or death from scalds.

Children, disabled and elderly are at highest risk of being scalded.

Review this instruction manual before setting temperature at water heater.

Feel water before bathing or showering.

Temperature limiting valves are available.

APPROXIMATE TIME/TEMPERATURE RELATIONSHIPS IN SCALDS	
120°F (49°C)	More than 5 minutes
125°F (52°C)	1½ to 2 minutes
130°F (54°C)	About 30 seconds
135°F (57°C)	About 10 seconds
140°F (60°C)	Less than 5 seconds
145°F (63°C)	Less than 3 seconds
150°F (66°C)	About 1½ seconds
155°F (68°C)	About 1 second

Upright Models (See Figure 1)

The hot and cold water connections are identified on the top of the water heater. Connect the hot and cold water lines to the installed nipples using unions. Install a listed temperature-pressure relief valve in the remaining fitting.

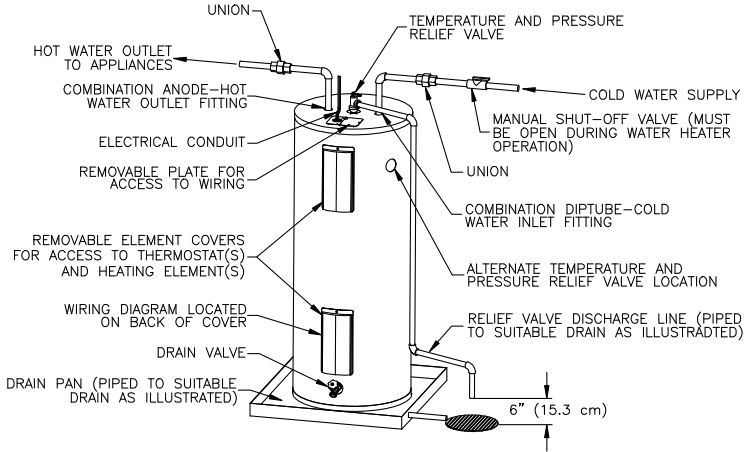

Figure 1

Utility Models (See Figure 2)

Utility models are supplied with inlet and outlet nipples located in a plastic bag attached to the side of the water heater. The hot and cold water connections are identified on the side of the water heater. Apply appropriate amount of thread sealant to the provided nipples and install them into the side of the tank. For 20 gallon utility models, install the supplied anode/nipple combination at the HOT outlet location. Connect the hot and cold water lines to the installed nipples using unions. Install a listed temperature-pressure relief valve in the opening on the side of the water heater. Install a vacuum relief anti-siphon device in the cold water inlet line.

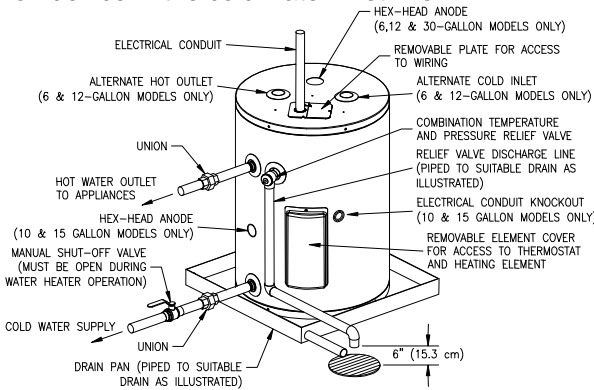

Figure 2

Electrical Connections

Before any electrical connections are made, be sure that the water heater is full of water and that the manual shut-off valve in the cold water supply line is open. Check the rating plate and wiring diagram before proceeding. This electric water heater was built and wired in accordance with the Underwriters Laboratories testing approvals requirements. The temperature limiting device is of the manual reset, trip-free type and has been factory installed to interrupt all ungrounded power supply conductors in the event of thermostat failure. Thermostats are factory set and wired in accordance with the wiring diagram fastened to the inside of the top access panel. The plumbing supplier in your area ordered this heater wired at the factory to comply with existing area codes, but local utility codes may require or allow other circuitry. The thermostats are factory set and wired in accordance with the wiring diagram affixed to the water heater next to the thermostat/element access cover. Consult your local power company to determine the correct electrical hook-up in order to meet local utility and building codes and in order to obtain the most economical rates. Also check to find out if you are required to obtain a permit before starting the installation.

The water heater must be well grounded. The green ground wire from the power supply shall be attached to the terminal marked for this purpose on the terminal block for all water heaters except 10 and 15 gallon utility models. For 10 and 15 gallon utility models, the ground wire shall be attached to the green ground screw located under the element access cover.

Upright and lowboy models are wired for “unbalanced” three phase delta branch circuit operation. Upright and lowboy models (only) may be converted to single phase and/or simultaneous operation as shown on the wiring diagram (see figure 3A and 3B). To ensure proper electrical connection, check the voltage and wiring configuration on the rating plate located on the front of the water heater.

Run the power leads from an adequately fused disconnect switch (not supplied) and connect the wires to the water heater according to the wiring diagram found in these installation and operation instructions (see figures 3A, 3B, 4 and 4A for correct wiring diagram) and located on the front of the water heater. Where longer runs are needed or local codes and ordinances require, an increase in wire size may be necessary. Consult local codes and/or your local power company for any specific requirements which may apply. In the absence of local codes and ordinances, refer to the National Electrical Code.

NON-SIMULTANEOUS
3 PHASE UNBALANCED

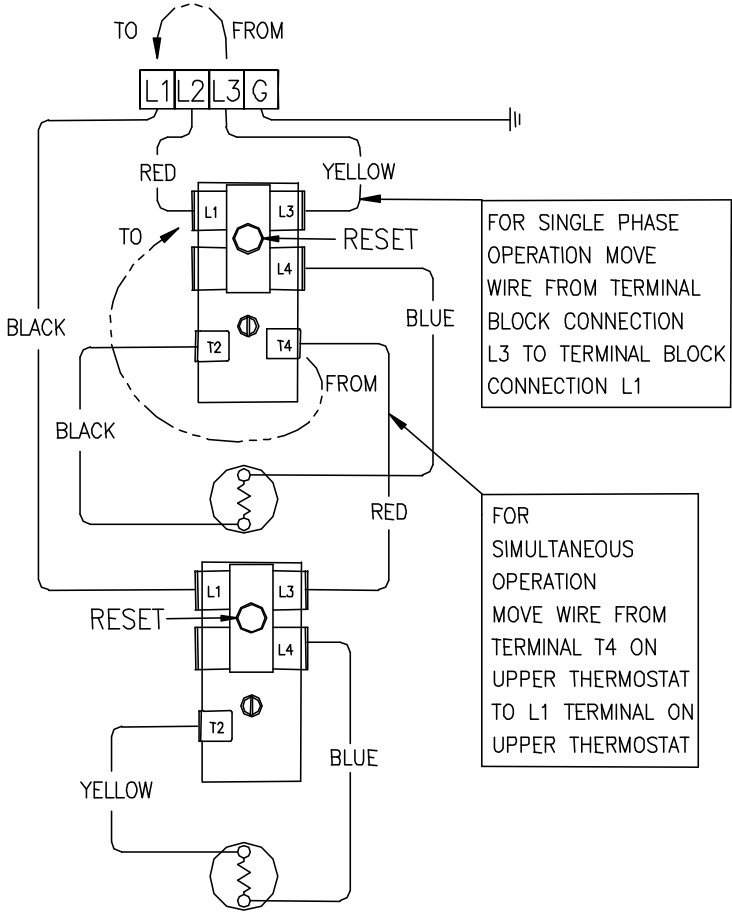

Figure 3A

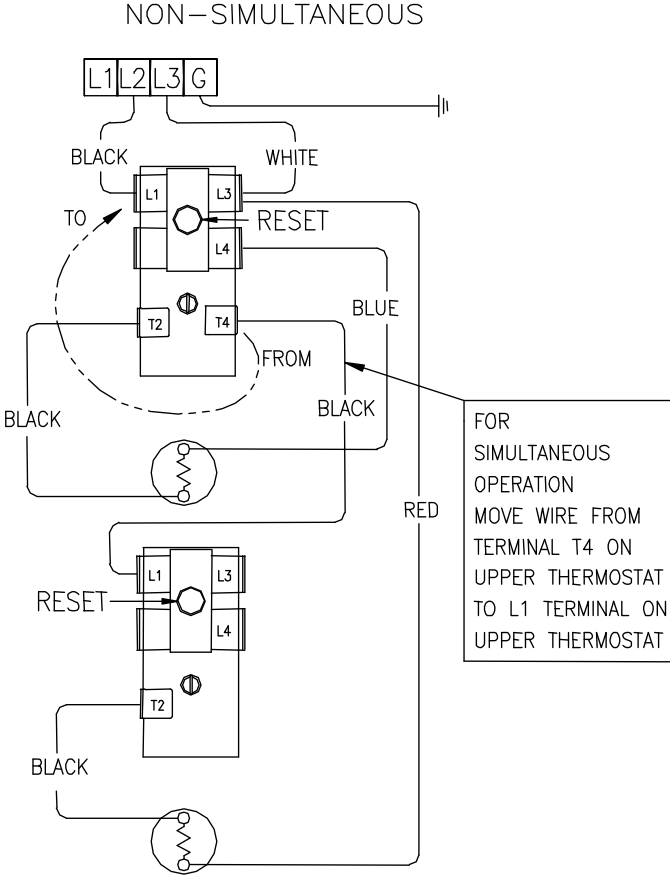

Figure 3B

Electrical Connections continued-

SINGLE ELEMENT MODELS
(WALL HUNG MODELS)
(ALL UTILITIES EXCEPT 10 & 15 GALLON)

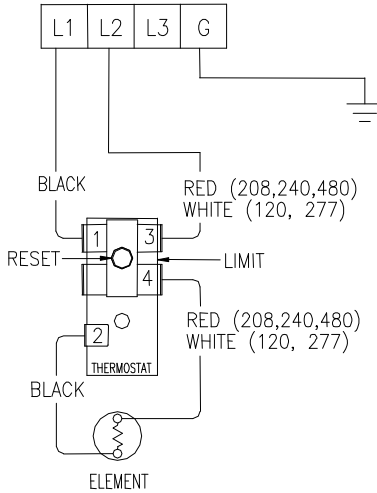

Figure 4

SINGLE ELEMENT MODELS
(10 & 15 GALLON UTILITY MODELS)

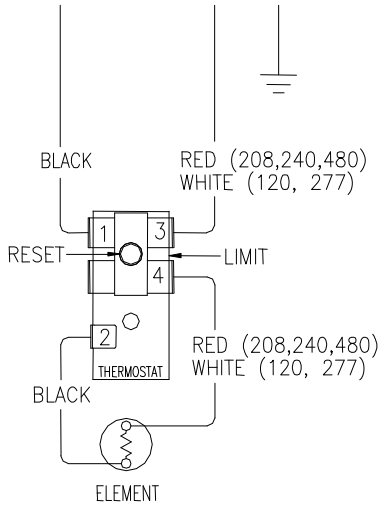

Figure 4A

Electrical Connections continued-

The following tables show the recommended fuse size for the maximum wattage supplied to the water heater. The maximum wattage and rate voltage are shown on the water heater data plate.

BRANCH CIRCUIT SIZING GUIDE							
Watt Load	Recommended over current protection rating			Copper wire size – AWG Based on N.E.C. Table 310-16			Approximate Recovery Gal./Hr. @100°F Rise
	120V	208V	240V	120V	208V	240V	
1500	15	15	15	12	14	14	6.1
2000	20	15	15	10	14	14	8.2
2500	30	15	15	10	14	14	10.2
3000	30	20	15	8	12	12	12.3
3500		20	20		10	12	14.3
4000		25	20		10	10	16.4
4500		30	25		10	10	18.4
5000		30	30		10	10	20.5
5500		35	30		8	10	22.5
6000		35	30		8	8	24.8
9000		50	45		8	6	36.9
10000		60	55		4	4	41.0
11000			30			4	45.1

FOR YOUR SAFETY

Increasing the wattage and/or voltage from the factory original equipment can require changes to the water heater and/or the electric service. Unauthorized modification of the water heater may create a hazard to life and property and will nullify the warranty. Contact your dealer or utility company before making any changes.

SINGLE PHASE FULL LOAD CURRENT DRAW (NON-SIMULTANEOUS OPERATION)							
Element Wattage	120V	208V	240V	277V	380V	415V	480V
1500/1500	12.5	7.2	6.3	5.4	3.9	3.6	3.1
2000/2000	16.7	9.6	8.3	7.2	5.3	4.8	4.2
2500/2500	20.8	12.0	10.4	9.0	6.6	6.0	5.2
3000/3000	25.0	14.4	12.5	10.8	7.9	7.2	6.3
3500/3500	N/A	16.8	14.6	12.6	9.2	8.4	7.3
4000/4000	N/A	19.2	16.7	14.4	10.5	9.6	8.3
4500/4500	N/A	21.6	18.8	16.2	11.8	10.8	9.4
5000/5000	N/A	24.0	20.8	18.8	13.2	12.0	10.4
5500/5500	N/A	N/A	22.9	19.9	14.5	13.3	11.5
6000/6000	N/A	N/A	N/A	21.7	15.8	14.5	12.5

Electrical Connections continued-

SINGLE PHASE FULL LOAD CURRENT DRAW (SIMULTANEOUS OPERATION)							
Element Wattage	120V	208V	240V	277V	380V	415V	480V
1500/1500	25.0	14.4	12.6	10.8	7.8	7.2	6.2
2000/2000	33.4	19.2	16.6	14.4	10.6	9.6	8.4
2500/2500	41.6	24	20.8	18.0	13.2	12.0	10.4
3000/3000	N/A	28.8	25.0	21.6	15.8	14.4	12.6
3500/3500	N/A	33.6	29.2	25.2	18.4	16.8	14.6
4000/4000	N/A	38.4	33.4	28.8	21.0	19.2	16.6
4500/4500	N/A	43.2	37.6	32.4	23.6	21.6	18.8
5000/5000	N/A	48.0	41.6	37.6	26.4	24.0	20.8
5500/5500	N/A	N/A	45.8	39.8	29.0	26.6	23.0
6000/6000	N/A	N/A	N/A	43.4	31.6	29.0	25.0

THREE PHASE (UNBALANCED DELTA) FULL LOAD CURRENT DRAW (NON-SIMULTANEOUS OPERATION: TERMINALS L1, L2 & L3)					
Element Wattage	208V	240V	380V	415V	480V
1500/1500	7.2	6.3	3.9	3.6	3.1
2000/2000	9.6	8.3	5.3	4.8	4.2
2500/2500	12.0	10.4	6.6	6.0	5.2
3000/3000	14.4	12.5	7.9	7.2	6.3
3500/3500	16.8	14.6	9.2	8.4	7.3
4000/4000	19.2	16.7	10.5	9.6	8.3
4500/4500	21.6	18.8	11.8	10.8	9.4
5000/5000	24.0	20.8	13.2	12.0	10.4
5500/5500	N/A	22.9	14.5	13.3	11.5
6000/6000	N/A	N/A	15.8	14.5	12.5

THREE PHASE (UNBALANCED DELTA) FULL LOAD CURRENT DRAW (SIMULTANEOUS OPERATION: TERMINAL L3 / TERMINALS L1 & L2)					
Element Wattage	208V	240V	380V	415V	480V
1500/1500	12.5/7.2	10.8/6.3	6.8/4.0	6.3/3.6	5.4/3.1
2000/2000	16.6/9.6	14.4/8.3	9.1/5.3	8.3/4.8	7.2/4.2
2500/2500	20.8/12.0	18.0/10.4	11.4/6.6	10.4/6.0	9.0/5.2
3000/3000	25.0/14.4	21.6/12.5	13.7/7.9	12.5/7.2	10.8/6.3
3500/3500	29.1/16.8	25.2/14.6	15.9/9.2	14.6/8.4	12.6/7.3
4000/4000	33.3/19.2	28.8/16.7	18.2/10.5	16.7/9.6	14.4/8.3
4500/4500	37.4/21.6	32.4/18.8	20.5/11.8	18.8/10.8	16.2/9.4
5000/5000	41.6/24.0	36.0/20.8	22.8/13.2	20.8/12.0	18.0/10.4
5500/5500	N/A	39.6/22.9	25.0/14.5	22.9/13.3	19.9/11.5
6000/6000	N/A	N/A	27.3/15.8	25.0/14.5	21.7/12.5

GENERAL OPERATION

Before closing the switch to allow electric current to flow to the water heater, make certain that the water heater is full of water and that the cold water inlet valve is open. Complete failure of the heating element(s) will result if they are not totally immersed in water at all times. Failure of the element(s) due to dry-firing is not covered by warranty.

When the switch is closed, the operation of this electric water heater is automatic. The thermostats are preset to the "HOT" setting to provide a water temperature of approximately 140°F (60°C) or below to reduce the risk of scald injury.

CAUTION

Scalding may occur within five (5) seconds at a temperature setting of 140°F (60°C).

Care must be taken whenever using hot water to avoid scalding injury. Certain appliances require high temperature hot water (such as dishwashers and automatic clothes washers).

TO FILL THE WATER HEATER

1. Close the water heater drain valve (if provided) by inserting a standard flat head screwdriver into the slot and turning clockwise.
2. Open the cold water supply shut-off valve.
3. Open several hot water faucets to allow air to escape from the system.
4. When a steady stream of water flows from the faucets, the water heater is filled. Close the faucets and check for water leaks at the water heater drain valve, combination temperature and pressure relief valve and the hot and cold water connections.

TO DRAIN THE WATER HEATER

Should it become necessary to completely drain the water heater, make sure you follow the steps below:

1. Disconnect the power supply to the water heater. Consult the plumbing professional or electric company in your area for service.
2. Close the cold water supply shut-off valve.
3. Open the drain valve (if provided) on the water heater by inserting a standard flat head screwdriver into the slot and turning counter-clockwise. The drain valve has threads on the end that will allow connection of a standard hose coupling. For those models not equipped with a drain valve, disconnect cold water inlet piping at a convenient connection location as close to an adequate drain as possible.

CAUTION! THIS WATER MAY BE HOT.

4. Open a hot water faucet to allow air to enter the system.

To refill the water heater, refer to "TO FILL THE WATER HEATER."

Thermostat Adjustment

⚠ CAUTION

Before adjusting thermostat(s), turn off power supply to the water heater.

The temperature of the water can be changed by adjusting the thermostat(s). Before any work is done on the water heater, disconnect all power to the water heater by opening the switch at the main electrical circuit breaker or fuse box. Remove the access panels or front panel on table tops, fold the insulation outward away from the controls. Set the thermostat(s) to the desired water temperature using a screwdriver to move the thermostat dial. The thermostat has been factory preset to approximately 140°F (60°C) or below. Rotate the temperature dial clockwise to increase water temperature. Replace the insulation making sure that the controls are well covered and that the plastic terminal shield has not been displaced; replace the access panel. The water heater is now ready for operation and the main switch can be closed.

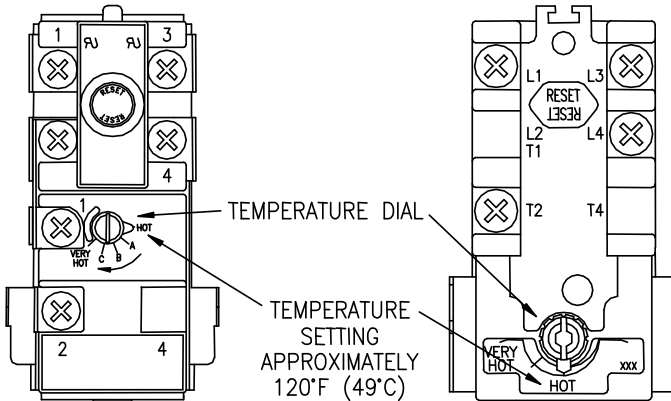

Figure 5

⚠ DANGER

Hotter water increases the risk of scald injury. Scalding may occur within five (5) seconds at a temperature setting of 140°F (60°C). To protect against hot water injury, install an ASSE approved mixing valve in the water system. This valve will reduce point of discharge water temperatures by mixing cold and hot water in branch water lines. A licensed plumbing professional or local plumbing authority should be consulted.

Note: This water heater is equipped with an energy cut out device to prevent overheating. Should overheating occur, turn off the electrical supply to the water heater and contact a qualified service technician.

MAINTENANCE

IMPORTANT

The water heater should be inspected at a minimum of annually by a qualified service technician for damaged components. **DO NOT** operate this water heater if any part is found damaged.

Shut off the electric power whenever the water supply to the water heater is off. Shut off the electric power and water supply, drain the heater completely to prevent freezing whenever the building is left unoccupied during the cold weather months. In order to insure efficient operation and long tank life, drain the water heater at least once a month through the drain valve until the water runs clear. Failure to do this may result in noisy operation and lime and sediment buildup in the bottom of the tank. Check the temperature-pressure relief valve to insure that the valve has not become encrusted with lime. Lift the lever at the top of the valve several times until the valve seats properly without leaking and operates freely.

WARNING

When lifting lever of temperature-pressure relief valve, hot water will be released under pressure. Be certain that any released water does not result in bodily injury or property damage. The magnesium anode rod should be inspected periodically and replaced when necessary to prolong tank life.

The following maintenance should be performed by a qualified service technician at the minimum periodic intervals suggested below. In some installations, the maintenance interval may be more frequent depending on the amount of use and the operating conditions of the water heater. Regular inspection and maintenance of the water heater will help to insure safe and reliable operation.

1. Annually, check the operation of the thermostat(s).
2. Bi-annually, check the seal around the heating elements for leaks. If there is any sign of leaking, disconnect the power supply to the water heater and contact the plumbing professional who installed this water heater or a qualified service technician.
3. At least once a year, check the combination temperature and pressure relief valve to insure that the valve has not become encrusted with lime. Lift the lever at the top of the temperature-pressure relief valve several times until the valve seats properly without leaking and operates freely.

▲ WARNING

When lifting lever of temperature-pressure relief valve, hot water will be released under pressure. Be certain that any released water does not result in bodily injury or property damage.

4. If the combination temperature and pressure relief valve on the appliance discharges periodically, this may be due to thermal expansion in a closed water supply system. Contact the water supplier or local plumbing inspector on how to correct this situation. Do not plug the combination temperature and pressure relief valve outlet for any reason.
5. Monthly, drain off a gallon of water from the water heater to remove silt and sediment.

▲ WARNING! THIS WATER MAY BE HOT.

6. A combination sacrificial anode rod/hot water outlet nipple has been installed to extend tank life. The anode rod should be inspected periodically (every 2 years) and replaced when necessary to prolong tank life. Water conditions in your area will influence the time interval for inspection and replacement of the anode rod. Contact the plumbing professional who installed the water heater or the manufacturer listed on the rating plate for anode replacement information. The use of a water softener may increase the speed of anode consumption. More frequent inspection of the anode is needed when using softened (or phosphate treated) water.

▲ CAUTION

FOR YOUR SAFETY, **DO NOT** ATTEMPT TO REPAIR THERMOSTAT(S), HEATING ELEMENTS, OR ELECTRICAL WIRING. REFER SUCH REPAIRS TO A QUALIFIED SERVICE TECHNICIAN.

Maintenance continued-

Contact your local plumbing supplier or plumbing professional for replacement parts or contact the company at the address displayed on the rating plate of the water heater.

For faster and better service, please provide the part name, model, and serial number(s) of the water heater(s) when ordering parts.

READ THE WARRANTY FOR A FULL EXPLANATION OF THE LENGTH OF TIME THAT PARTS AND THE WATER HEATER ARE WARRANTED.

Manufactured under one or more of the following U.S. Patents: RE.34,534; B1 5,341,770; 4,416,222; 4,628,184; 4,669,448; 4,672,919; 4,808,356; 4,829,983; 4,861,968; 4,904,428; 5,000,893; 5,023,031; 5,052,346; 5,081,696; 5,092,519; 5,115,767; 5,199,385; 5,277,171; 5,372,185; 5,485,879; 5,574,822; 5,596,952; 5,660,165; 5,682,666; 5,761,379; 5,943,984; 5,954,492; 5,988,117; 6,142,216; 6,684,821; 7,063,132; 7,007,748; Other U.S. and Foreign patent applications pending. Current Canadian Patents: 1,272,914; 1,280,043; 1,289,832; 2,045,862; 2,092,105; 2,107,012; 2,108,186; 2,112,515

Complete the following information and retain for future reference:

Model No: _____

Serial No: _____

Service Phone

Days: _____ Nights: _____

Address: _____

Supplier: _____

Supplier Phone No: _____



RESIDENTIAL ELECTRIC AND LIGHT DUTY COMMERCIAL ELECTRIC WATER HEATERS



Photo is of
M-2-50T6DS

SERVICE MANUAL

Troubleshooting Guide
and Instructions for Service

(To be performed ONLY by
qualified service providers)

Models Covered by This Manual:

Residential Energy Saver:
M1 & M2(HE) Upright Models.
M1 & M2 Lowboy Models.
M1 & M2 Utility Models.
M1 & M2 Wall Hung Models.

Light Duty Energy Saver:
LD Upright Models.
LD Utility Models.
LD Lowboy.
LD Wall Hung.

Dairy Barn Deluxe Energy Saver:
DB Models.

Table of Contents

	<u>Page</u>	<u>Service Procedure</u>
Introduction	2	
Tools.....	2	
General Information	3	---
Sequence of Operation	6	---
Single Element Operation	6	---
Double Element, Non-Simultaneous, Single Phase.....	7	---
Double Element, Simultaneous, Single Phase, 4 wire Service	8	---
Double Element, Non-Simultaneous, 3 Phase	9	---
Double Element, Simultaneous, 3 Phase	10	---
Double Element, Non-Simultaneous, Single Phase, Off Peak	11	---
Troubleshooting	12	---
Line Voltage and High Limit ECO Testing.....	14	RE-I
Heating Element Testing	15	RE-II
Residential Thermostat Testing	16	RE-III
Single Element	16	
Double Element, 4 wire, Simultaneous, Single Phase	16	
Double Element, Non-Simultaneous, Single Phase	17	
Double Element, Non-Simultaneous, 3 Phase	19	
Double Element, Simultaneous, 3 Phase	21	
Double Element, Non-Simultaneous, Single Phase, Off Peak	23	
Light Duty Commercial Thermostat Testing	25	RE IV
Double Element, Non-Simultaneous, Single Phase	25	
Double Element, Simultaneous, Single Phase	27	
Double Element, Non-Simultaneous, 3 Phase	29	
Double Element, Simultaneous, 3 Phase	31	
Thermostat Removal and Replacement	33	RE-V
Heating Element Removal and Replacement	34	RE-VI
Dip Tube and Anode Inspection and Replacement	35	RE-VII
Generic Parts List	36	---

Introduction

This service manual is designed to aid service and maintenance professionals on the function, proper diagnosis and repair of Bradford White residential electric and light duty commercial electric water heaters.

The text and illustrations in this manual provide step by step instructions to facilitate proper operation and troubleshooting procedures. Contact the Bradford White Technical Support Group immediately if diagnosis can not be made using the methods described in this service manual.

Tools

- Multi Meter.
- Phillips Head Screw Driver.
- 1-½ Deep Well Socket (element removal).
- Thermometer.
- ¼" Nut Driver.
- Drain Hose.
- Various Hand Tools: Pipe Wrench, Channel Locks, Pliers (common & needle nose), Wire cutters, Wire Strippers, Flash Light.

Commonly Used Formulas

Amps = $\frac{\text{Watts}}{\text{Volts}}$ (for single phase units) Example $4500\text{W}/240\text{V} = 18.75\text{A}$

Amps = $\frac{\text{Watts}}{\text{Volts} \times 1.732}$ (for balanced 3 phase units) Example $4500\text{W}/240\text{V} \times 1.732 = 10.82\text{A}$

Watts = Amps x Volts Example $18.75\text{A} \times 240\text{V} = 4500\text{W}$

Ohms = $\frac{\text{Volts}^2}{\text{Watts}}$ Example $(240\text{V})^2 / 4500\text{W} = 12.8 \text{ Ohms}$

Common Service Wire Configurations

120 VOLT

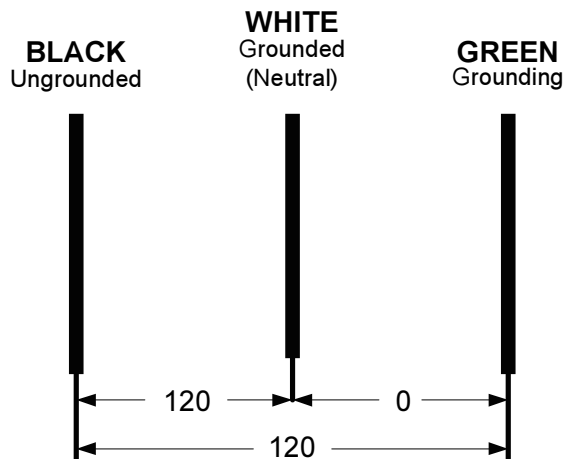

240 VOLT

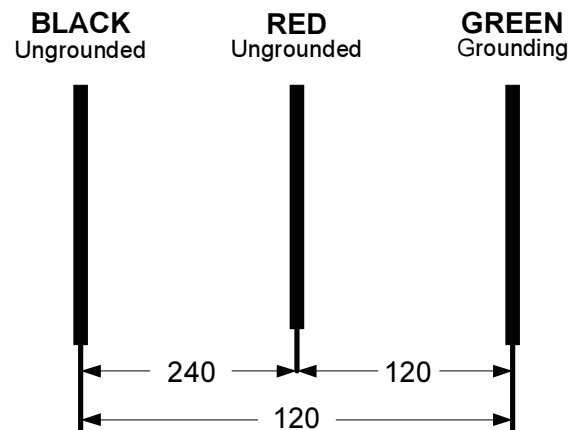

208 3Ph

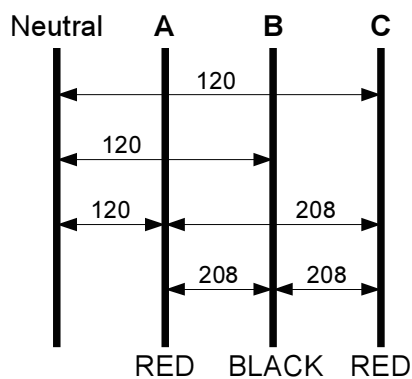

240 3Ph

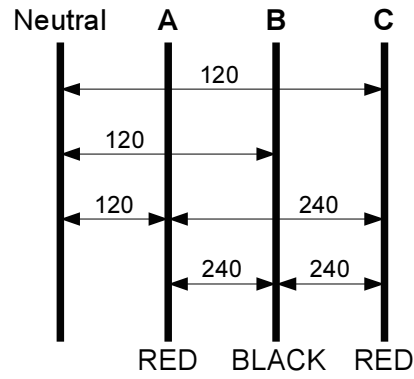

480 3Ph/277 1 Ph

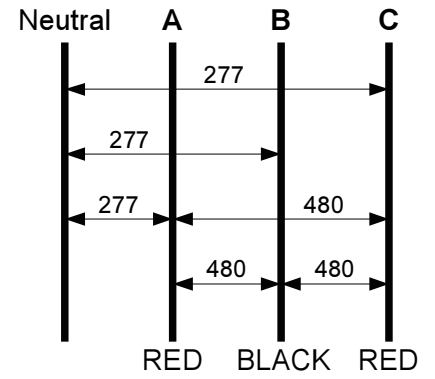

Wattage Limitations at Various Voltages

Residential Electric Upright M1 & M2 Series (Non-Simultaneous operation)
 Residential High Efficiency Upright M2HE Series (Non-Simultaneous operation)
 Residential Electric Lowboy M1 & M2 Series (Non-Simultaneous Operation)
 Dairy Barn Deluxe DB Series (Non-Simultaneous Operation)

Maximum Wattage	Element Upper/Lower	Voltage
3,000	3,000/3,000	120
6,000	6,000/6,000	208, 240
6,000	6,000/6,000	277, 480

Residential Electric Upright M1 & M2 Series (Simultaneous Operation)
 Residential High Efficiency Upright M2HE Series (Simultaneous Operation)
 Residential Electric Lowboy M1 & M2 Series (Simultaneous Operation)
 Light Duty Commercial Electric LD Series (Non-Simultaneous Operation)
 Light Duty Commercial Electric LD Series (Simultaneous Operation)
 Dairy Barn Deluxe DB Series (Simultaneous Operation)

Maximum Wattage	Element Upper/Lower	Voltage
3,000	1,500/1,500	120
10,000	5,000/5,000	208
11,000	5,500/5,500	240
12,000	6,000/6,000	277, 480

Residential Electric Utility Series (Single Element Operation)
 Light Duty Utility Series (Single Element Operation)

Maximum Wattage	Single Element	Voltage
3,000	3,000	120
6,000	6,000	208, 240
6,000	6,000	277
6,000	6,000	480

Surface Mounted Thermostats

Surface mounted thermostats are mounted into a bracket which holds the thermostat against the side of the tank. Surface mounted thermostats respond to tank surface temperatures to sense a call for heat, set point temperature settings and high limit (ECO) activation. It is important that the entire back surface of the thermostat is in full contact or flush with the tank. Improperly mounted thermostat will lead to improper heater operation.

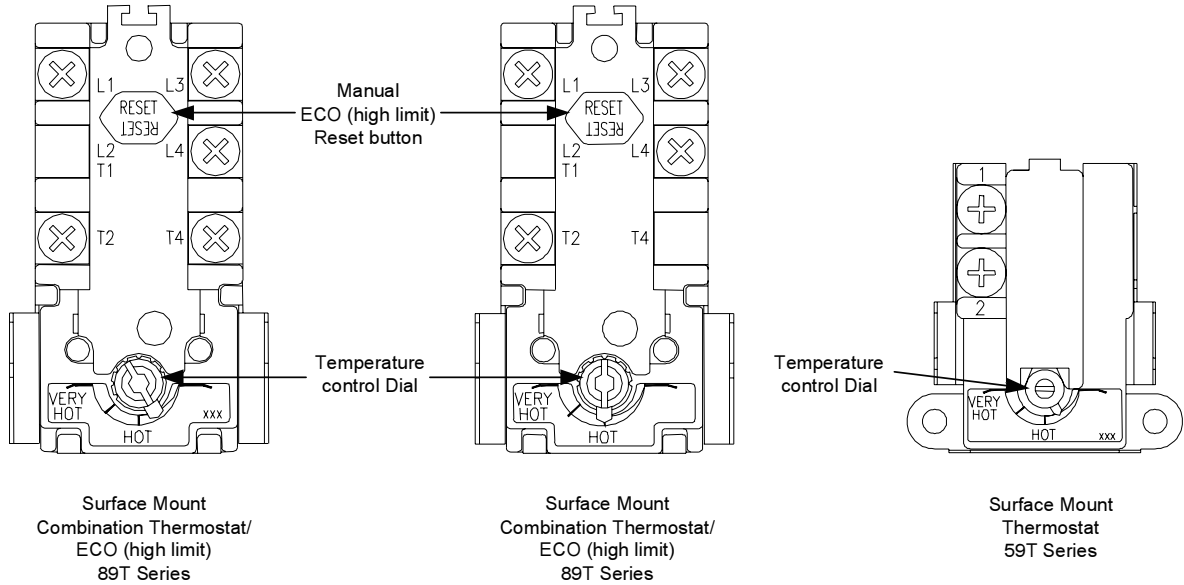

Direct Immersion “Screw-in” Type Heating Element

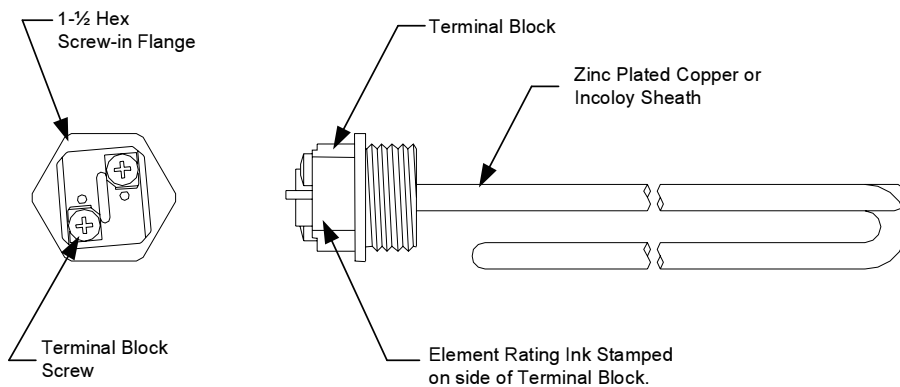

Residential and light duty commercial electric water heaters are designed to operate using several different operating modes. The common modes and sequence of operation are as follows:

1. Single Element Operation.
2. Double Element Non-Simultaneous Operation (single phase).
3. Double Element Non-Simultaneous Operation (3 phase).
4. Double Element Simultaneous Operation (single phase).
5. Double Element Simultaneous Operation (3 phase).

Sequence of Operation- Single Element Operation.

- 1 Line voltage is applied across terminals L1 & L3 of the thermostat. ECO is closed, so there is voltage at terminal L4 and to one side of the element.

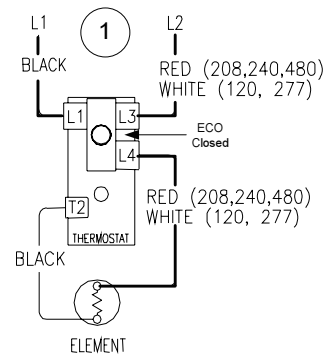

- 2 Tank is cold therefore thermostat is closed at terminal T2 (calling for heat). This completes the circuit and allows current to flow through the element.

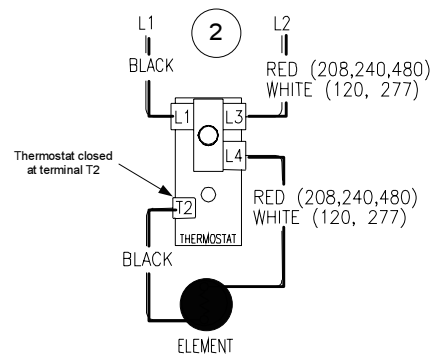

- 3 When the thermostat is satisfied, it opens at terminal T2 interrupting current flow through the element. System is now in stand-by mode, waiting for the next call for heat.

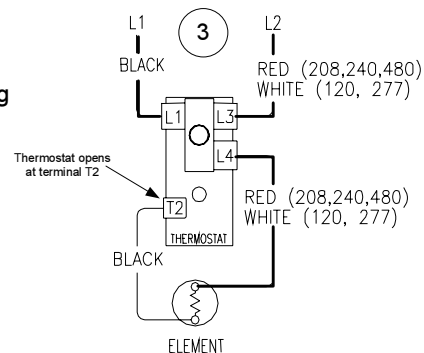

Non-Simultaneous and Simultaneous Operation

Double element electric water heaters are designed to operate in a Non-Simultaneous or Simultaneous mode.

Non-Simultaneous Mode: Allows only one heating element to operate at a time. For example, when the tank is cold, the upper element is energized first, heating the top of the tank. Only when the upper thermostat is satisfied, the upper element is de-energized and power is directed to the lower thermostat, energizing the lower element and heating the bottom portion of the tank until the lower thermostat is satisfied. As hot water is drawn off the tank, it is replaced with cold water delivered through the dip tube to the bottom of the tank. The bottom of the tank cools, the lower thermostat will call for heat energizing the lower element. If enough hot water is drawn from the tank, the top portion of the tank cools and the upper thermostat will call for heat, de-energizing the lower element and allowing only the top element to be energized until the upper thermostat is satisfied.

Simultaneous mode: allows both heating elements to operate at the same time. That is, if either thermostat (upper or lower) is calling for heat, the corresponding heating element is energized independent of the other.

Sequence of Operation- Double Element, Non-Simultaneous Operation, Single Phase.

- 1 Line voltage is applied across terminals L1 & L3 of the upper thermostat. ECO is closed, so there is voltage at terminal L4 and to one side of the upper and lower elements.
- 2 Tank is cold therefore both thermostats are closed at terminal T2 & 2 (calling for heat). The circuit is complete through the upper thermostat only, allowing current to flow through upper element.
- 3 When upper thermostat is satisfied, it opens at terminal T2 interrupting current flow through upper element, and closes at terminal T4 allowing voltage to pass to terminal 1 of lower thermostat. This completes the circuit through the lower thermostat and allows current flow through lower element.
- 4 When the lower thermostat is satisfied, it opens at terminal 2 interrupting current flow through lower element. The system is now in stand-by mode waiting for the next call for heat

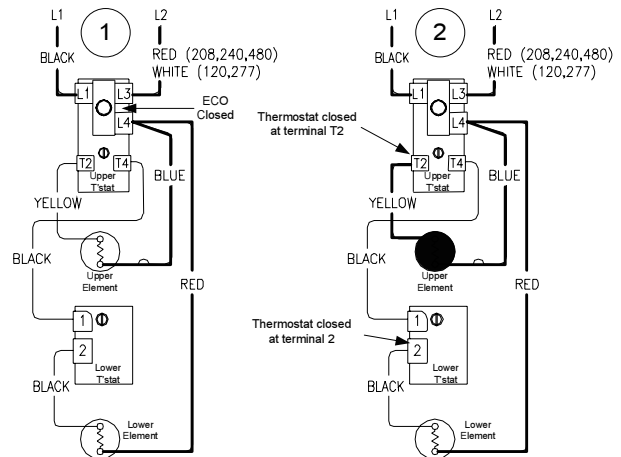

- 5 The lower thermostat/element combination will generally cycle on and off more often than the upper. In some cases, such as a cold tank or in high demand periods, the upper thermostat will call for heat (opening at terminal T4 and closing at terminal T2) prior to the lower thermostat being satisfied. This will interrupt current flow through the lower thermostat and element and allow current to flow through the upper element only. When the upper thermostat is satisfied, it resumes operation as described in sequence #3 above.

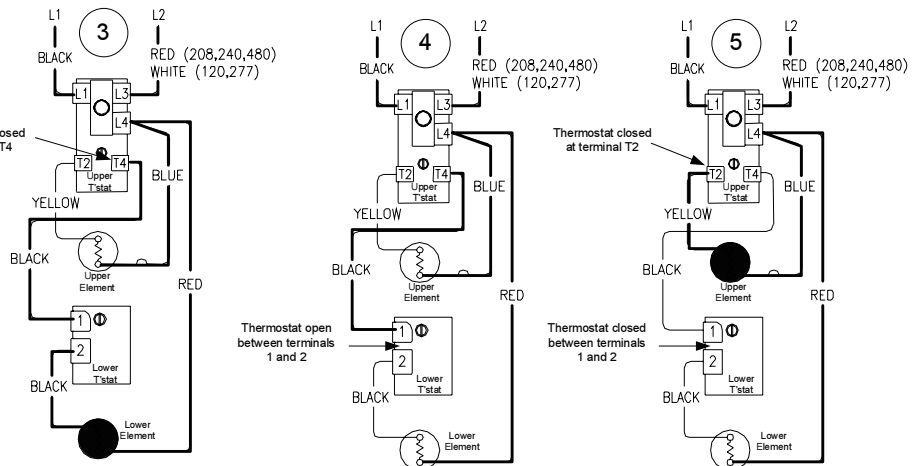

A 4 wire, double element heater wired for simultaneous operation is essentially two single element systems operating independently. The heaters are wired internally with two independent circuits, one circuit for each thermostat/element combination. When installed using a two wire service, the blue and red (or white) wires will be connected together, likewise black and yellow wires will be connected together.

Sequence of Operation- Double Element, Simultaneous Operation, Single Phase, 4 wire service installation.

- 1 Line voltage from circuit one is applied across terminals L1 & L3 of the lower thermostat. Likewise, line voltage from circuit two is applied across terminals L1 & L3 of the upper thermostat. ECO in both upper and lower thermostat is closed, so there is voltage at terminal L4 of each thermostat and to one side of the upper and lower elements.
- 2 Tank is cold therefore both thermostats are closed at terminal T2 (calling for heat). This completes the circuit through the thermostats and allows current to flow through the elements.

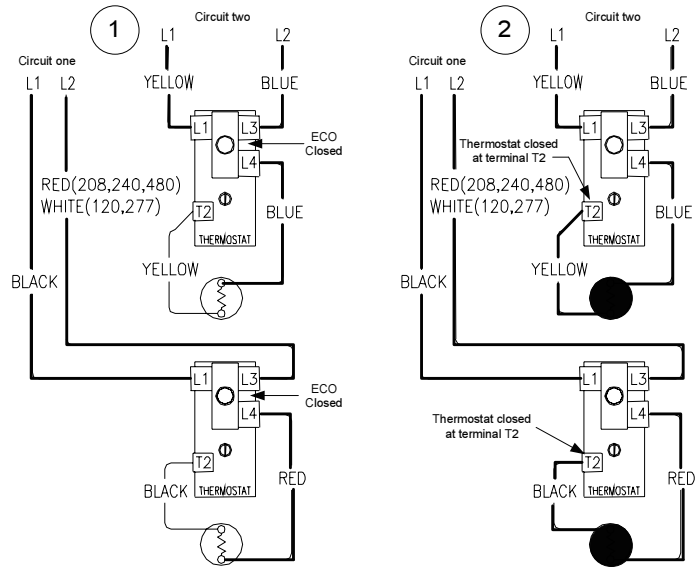

- 3 When either thermostat is satisfied, it will open at terminal T2, interrupting current flow through the corresponding element. As both thermostats satisfy, the system will be in stand-by mode waiting for the next call for heat. Thermostats will operate independent of the other.

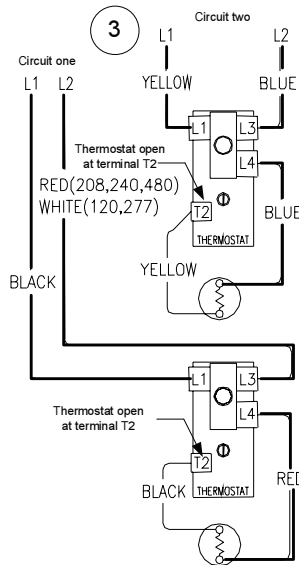

Sequence of Operation- Double Element, Non-Simultaneous Operation, 3 Phase.

- 1 Line voltage is applied across terminals L1 & L3 of upper thermostat. Likewise, Line voltage is applied to terminal L3 of lower thermostat. ECO in both upper & lower thermostat is closed, so there is voltage at terminal L4 of both thermostats and to one side of both upper & lower elements.
- 2 Tank is cold therefore both thermostats are closed at terminal T2 (calling for heat). The circuit is complete through the upper thermostat only allowing current to flow through the upper element.
- 3 When the upper thermostat is satisfied, it opens at terminal T2 interrupting current flow through upper element, and closes at terminal T4 allowing voltage to pass to terminal L1 of lower thermostat. This completes the circuit through the lower thermostat allowing current flow through lower element.
- 4 When the lower thermostat is satisfied, it opens at terminal T2 interrupting the current flow through the lower element. The system is now in stand-by mode waiting for the next call for heat.
- 5 The lower thermostat/element combination will generally cycle on and off more often than the upper. In some cases, such as a cold tank or in high demand periods, the upper thermostat will call for heat (opening at terminal T4 and closing at terminal T2) prior to the lower thermostat being satisfied. This will interrupt current flow through the lower thermostat and element and allow current to flow through the upper element only. When the upper thermostat is satisfied, it resumes operation as described in sequence #3 above.

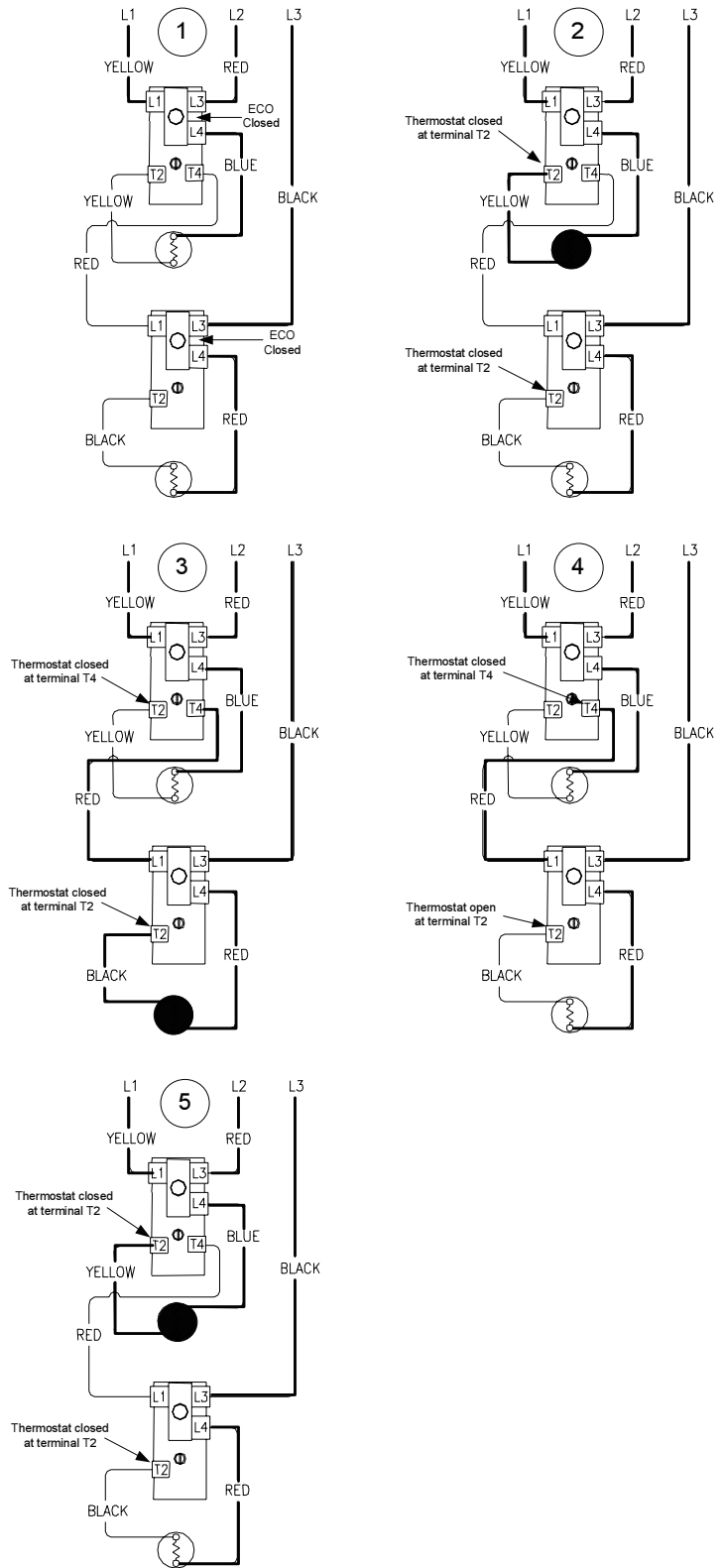

Sequence of Operation- Double Element, Simultaneous Operation, 3 Phase.

1 Line voltage is applied across terminals L1 & L3 of upper thermostat. Line voltage also extends to terminal L1 of lower thermostat. Also, line voltage is applied to terminal L3 of lower thermostat. ECO in both upper & lower thermostat is closed, so there is voltage at terminal L4 of both thermostats and to one side of both upper & lower elements.

2 Tank is cold therefore both thermostats are closed at terminal T2 (calling for heat). This completes the circuit through the thermostats and allows current to flow through the elements.

3 When either thermostat is satisfied, it will open at terminal T2, interrupting current flow through the corresponding element. As both thermostats satisfy, the system will be in stand-by mode waiting for the next call for heat. Thermostats will operate independent of the other.

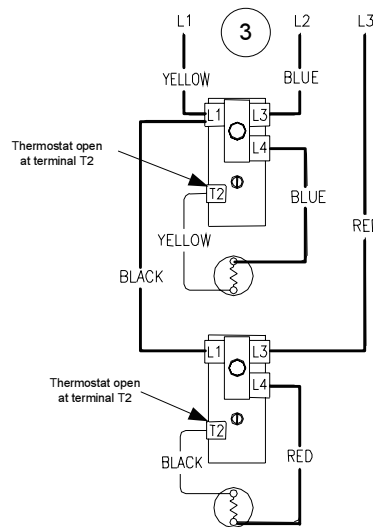
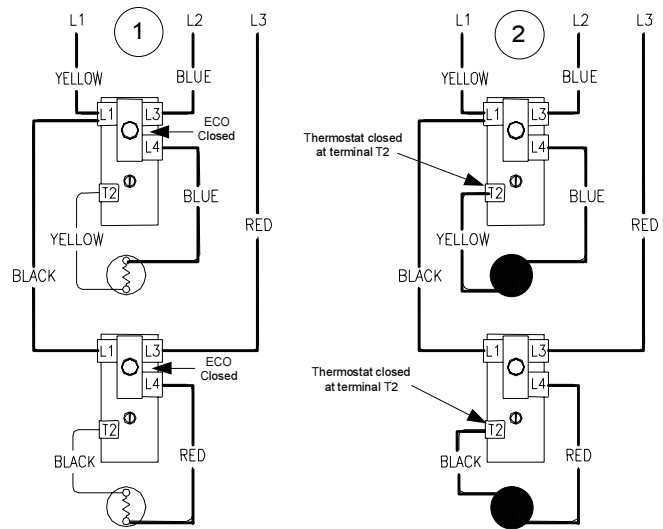

Some electric utility companies will offer discounts for using electricity during "Off Peak" Times of the day. The system allows the use of an "Off Peak" meter, which interrupts power to the lower element during high power demand periods.

Sequence of Operation- Double Element, Non-Simultaneous Operation, Single Phase, Off Peak.

- 1 Line voltage is applied across terminals L1 & L3 of the upper thermostat. Line voltage from off peak meter is supplied to terminal L1 of lower thermostat. ECO in the upper thermostat is closed, so there is voltage at terminal L4 of upper thermostat and to one side of the upper element.
- 2 Tank is cold therefore both thermostats are closed at terminal T2 (calling for heat). The circuit is complete through the upper thermostat only, allowing current to flow through upper element.
- 3 When upper thermostat is satisfied, it opens at terminal T2 interrupting current flow through upper element, and closes at terminal T4 allowing voltage to pass to one side of the lower element. This completes the circuit through the lower thermostat and off peak meter allowing current flow through lower element.
- 4 When the lower thermostat is satisfied, it opens at terminal T2 interrupting current flow through lower element. The system is now in stand-by mode waiting for the next call for heat
- 5 During peak power demand periods as determined by the local utility, the off peak meter will interrupt power to terminal L1 of lower thermostat. Only the top thermostat/element combination is allowed to operate during this period.

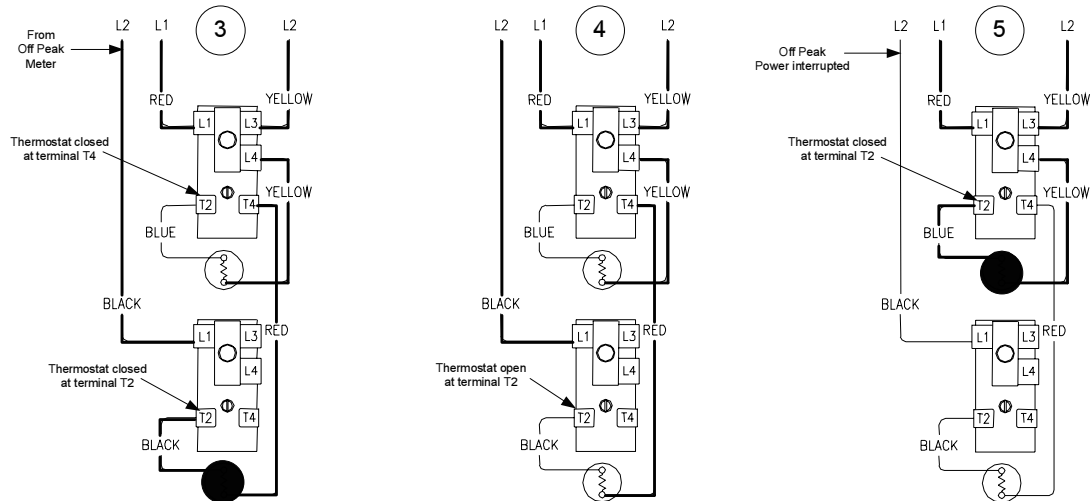
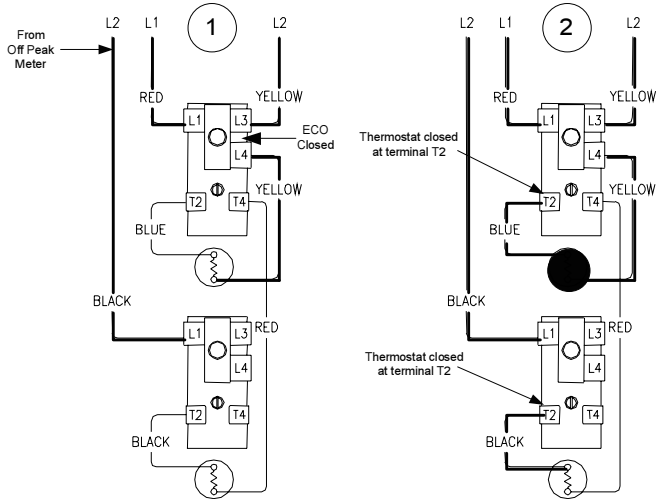

Most common cause for improper electric water heater operation can be linked to heating element failure.

When troubleshooting an electric water heater with the incidence of “No Hot Water” or “Insufficient Amount of Hot Water” Its always a good idea to check the heating elements first following the procedure on page 15.

Common Heating Element Failures Are:

1. **Dry Firing.** Element may be partially submerged in water or most likely, completely exposed with no water in tank. In some cases sediment or lime build up around an element can eventually cause an air pocket, and within seconds, result in a dry fired element. At this point the element becomes inoperative. When element replacement is required, be sure tank is full of water prior to energizing the water heater.
2. **Grounded Element.** An element with a short circuit to ground will in most cases cause the circuit breaker in the service panel to open or shut off. In some cases there may not be enough current draw for the circuit breaker to open. This will allow the heating element to be in continuous operation resulting in over heated water, limited only by the ECO or Energy Cut Off located in the thermostat. Repeated actuation of the ECO reset button on the thermostat usually is the result of a grounded element.
3. **Sediment build up.** Slow hot water recovery can usually be traced back to sediment or lime build up around heating element. Sediment build up can also over time cause a dry fired element.

Illustration 1, below shows a common “Screw-In” type heating element identifying certain features commonly referred to throughout this manual.

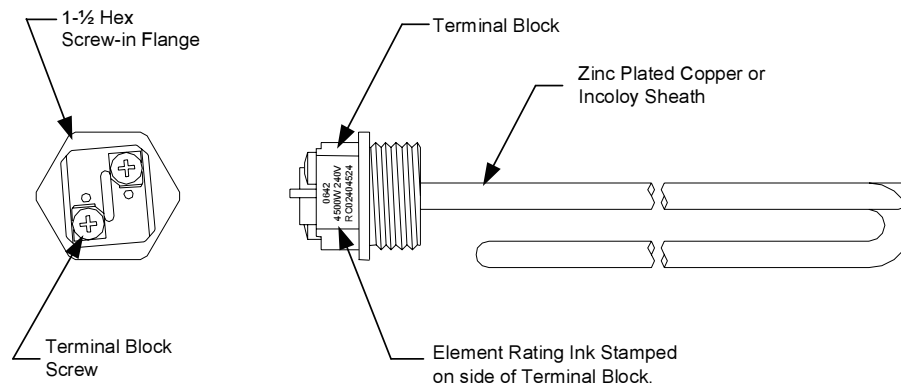

Illustration 1
**Typical Direct Immersion “Screw-In”
Type Heating Element**

Quick Step Plan to Hot Water

1. TURN OFF power to water heater and check all wire connections to insure they are tight and corrosion free.
2. Turn power "ON" and determine that service voltage is present, and the high limit (ECO) has not actuated (see procedure on page 14).
3. Check for inoperative heating element (see procedure on page 15).
4. Check for proper thermostat operation (see procedures beginning on page 16). NOTE: Thermostat testing procedures assume items 2 and 3 above are in working order.

⚠ WARNING
High voltage exposure. Use caution when making voltage checks to avoid personal injury.

<u>SYMPTOM</u>	<u>PROBABLE CAUSE</u>	<u>CORRECTIVE ACTION</u>	<u>SERVICE PROCEDURE</u>
No Hot Water	<ol style="list-style-type: none"> 1. No Power to heater. 2. Loose wire connections. 3. Inoperative upper heating element. 4. Inoperative upper thermostat. 5. Open ECO. 	<ol style="list-style-type: none"> 1. Check fuses or circuit breakers in service panel. 2. Check all wire connections. 3. Check heating element(s). Replace as needed. 4. Check thermostat(s) operation. Replace as needed. 5. Check ECO. Reset or replace thermostat(s) as needed. 	<ol style="list-style-type: none"> 3. See Service Procedure RE-II, Page 15. 4. See Service Procedure RE-III, Page 16. 5. See Service Procedure RE-I, Page 14.
Not Enough Hot Water	<ol style="list-style-type: none"> 1. Inoperative lower heating element. 2. Thermostat(s) set to low. 3. Inoperative thermostat(s). 4. Loose wire connection. 5. Sediment or lime build up on element(s). 6. High demand period. 7. Undersized heater. 8. Very cold inlet water to heater. 9. Plumbing connections reversed. 10. Damaged dip tube. 	<ol style="list-style-type: none"> 1. Check heating element(s), replace as needed. 2. Increase thermostat setting. 3. Check thermostat(s), replace as needed. 4. Check all wire connection. 5. Remove heating element(s) and check for lime build up. 6. Reduce demand. 7. Replace with larger heater. 8. Temper water to heater. 9. Correct plumbing connections. 10. Check dip tube, replace as needed. 	<ol style="list-style-type: none"> 1. See Service Procedure RE-II, Page 15. 3. See Service Procedure RE-III, Page 16. 5. See Service Procedure RE-VI, Page 34. 10. See Service Procedure RE-VII, Page 35.
Slow Hot Water Recovery	<ol style="list-style-type: none"> 1. Sediment or lime build up on element(s). 2. Loose wire connections. 3. Inoperative thermostat(s). 4. Derated heating element installed. 	<ol style="list-style-type: none"> 1. Remove heating element(s) and check for lime build up. 2. Check all wire connections. 3. Check thermostat(s), replace as needed. 4. Check terminal block of element for proper voltage and wattage rating. 	<ol style="list-style-type: none"> 1. See Service Procedure RE-VI, Page 34. 3. See Service Procedure RE-III, Page 16.
Over Heated Water or Continues Operation	<ol style="list-style-type: none"> 1. Thermostat not in contact with tank. 2. Grounded heating element(s). 3. Thermostat set to high. 4. Inoperative thermostat(s). 5. Inoperative ECO. 6. Undersized water heater. 	<ol style="list-style-type: none"> 1. Position thermostat flush with tank surface. 2. Check heating element(s). Replace as needed. 3. Adjust thermostat(s) to desired setting. 4. Check thermostat(s), replace as needed. 5. Check ECO, replace thermostat as needed. 6. Replace with larger heater. 	<ol style="list-style-type: none"> 1. See Service Procedure RE-V, Page 33. 2. See Service Procedure RE-II, Page 15. 4. See Service Procedure RE-III, Page 16. 5. See Service Procedure RE-I, Page 14.
Noisy (singing or hissing) Elements	<ol style="list-style-type: none"> 1. Lime formation on elements. 	<ol style="list-style-type: none"> 1. Remove and clean heating elements. Replace as needed. 	<ol style="list-style-type: none"> 1. See Service Procedure RE-VI, Page 34.

Line Voltage Testing

1. Turn "OFF" power to water heater.
2. Remove access cover(s) from front of water heater. Remove insulation and plastic cover from thermostat.
3. Set multi-meter to volts AC.
4. Turn power "ON" to water heater.
5. Check voltage across terminals L1 & L3 of upper thermostat (see illustration 2).

- A) Rated voltage IS present, power to the water heater is okay.
- B) Rated voltage NOT present, Check circuit breaker at service panel.

⚠ WARNING

High voltage exposure. Use caution when making voltage checks to avoid personal injury.

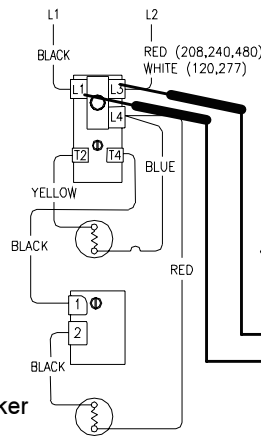

Illustration 2

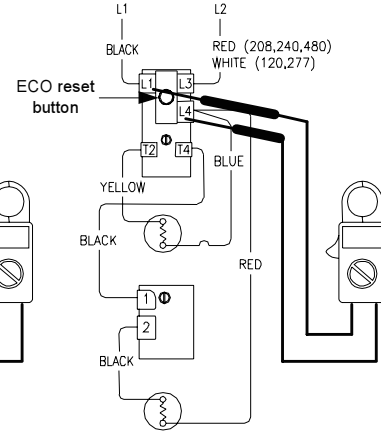

Illustration 3

High Limit (ECO) Testing

1. Check voltage across terminals L1 & L4 upper thermostat (see illustration 3).
 - A) Rated Voltage IS present, ECO is okay.
 - B) Rated voltage NOT present, proceed to step 2.
2. Turn power "OFF" to water heater and firmly press ECO reset button on thermostat(s). Turn power "ON" and recheck voltage across terminals L1 & L4 of upper thermostat (see illustration 3).
 - A) Rated voltage IS present, the ECO has opened indicating the water in the tank is or has over heater. Check the following:
 1. Thermostat must be in full contact with tank.
 2. Be sure heating element(s) is not shorted to ground (see page 15).
 3. Proper thermostat operation (see procedures beginning on page 16).
 - B) Rated voltage NOT present, water in tank may be over heated.
 1. If water is hot, turn "OFF" power to water heater and flow water through tank to cool below set point of upper thermostat. Recheck voltage per step 1.
 2. If water is cool, Replace upper thermostat.

Testing For Open Or Burned Out Element.

- Step 1. **TURN OFF POWER TO WATER HEATER.**
- Step 2. Remove access cover(s) from front of water heater. Remove insulation and plastic cover from thermostat.
- Step 3. Disconnect wires from heating element.
- Step 4. Set multi-meter to "ohms" setting.
- Step 5. Touch probes of multi-meter to screw terminals of heating element (see illustration 4).
- Step 6. Reading should be 12.8 ohms (±6%) for a 240 volt, 4500 watt element:

$$\text{Ohms} = \frac{\text{Volts}^2}{\text{Watts}}$$

A reading outside the range using the formula above (±6%), indicates a bad element and the element must be replaced.

⚠ WARNING
High voltage exposure. Be sure power is turned OFF to water heater prior to performing this procedure.

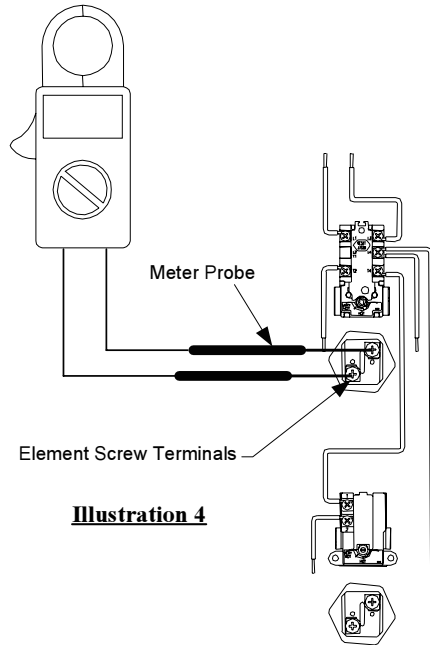

Illustration 4

Testing For Heating Element Short Circuit To Ground.

- Step 1. **TURN OFF POWER TO WATER HEATER.**
- Step 2. Remove access cover(s) from front of water heater. Remove insulation and plastic cover from thermostat.
- Step 3. Disconnect wires from heating element.
- Step 4. Set multi-meter to "ohms" setting.
- Step 5. Touch one probe of multi-meter to either screw terminal of heating element and the other on the element flange (see illustration 5). There should be no reading on the ohm meter. Any reading indicates a grounded element and the element must be replaced. Repeat this step for the other screw terminal.

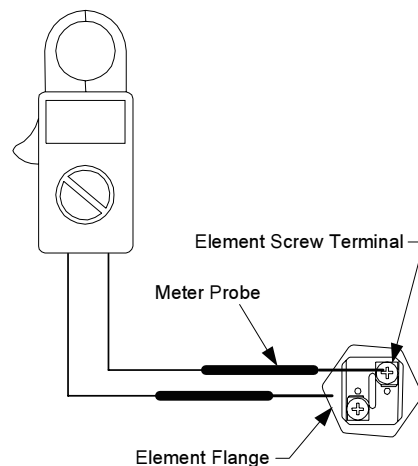

Illustration 5

Single Element Operation or Double Element, 4 Wire, Simultaneous, Single Phase Operation.

⚠ WARNING
High voltage exposure. Use caution to avoid personal injury during this procedure.

Water In Tank Is Cold With Power ON.

1. This procedure assumes line voltage, ECO and elements are in working order.
2. Turn power "ON" to water heater.
3. Set multi-meter to "Volts AC".
4. Check across terminals L4 and T2 of thermostat (see illustration 6).
 - A) Rated voltage NOT present, Recheck ECO. If ECO is okay, replace thermostat.
 - B) Rated voltage IS present, proceed to next step.
5. Check across element terminals (see illustration 7).
 - A) Rated voltage NOT present, check wire connections from thermostat to element.
 - B) Rated voltage IS present, Repeat element testing see page 15.

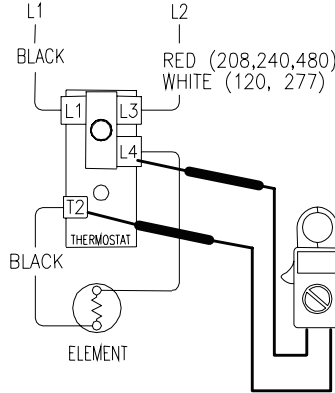

Illustration 6

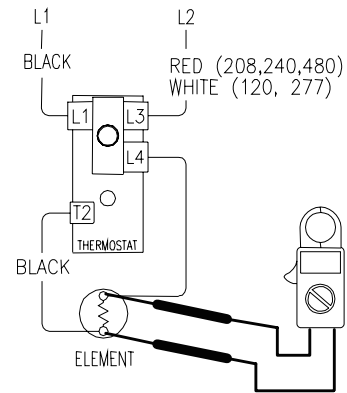
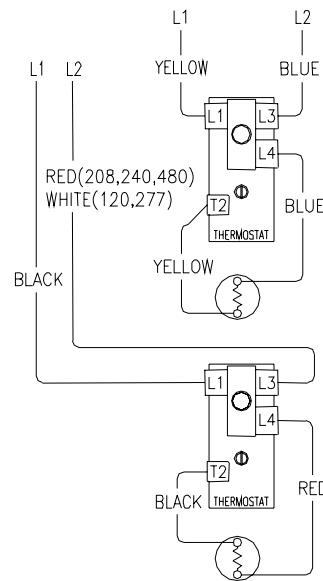

Illustration 7

Water Temperature In Tank Is Above Thermostat Setting.

1. This procedure assumes line voltage, ECO and elements are in working order.
2. Turn power "ON" to water heater.
3. Set multi-meter to "Volts AC".
4. See illustration 6 above, check across terminals L4 and T2 of thermostat.
 - A) Rated voltage IS present, replace thermostat.
 - B) Rated voltage NOT present, thermostat is okay.
 - C) Lower than rated voltage IS present, recheck for grounded element (see page 15).



Reference 4 Wire, Simultaneous, Single Phase Wiring diagram.

NOTE: Wiring consists of two single element configurations operating independently.

Double Element, Non-Simultaneous, Single Phase Operation.

⚠ WARNING
High voltage exposure. Use caution to avoid personal injury during this procedure.

Water In Tank Is Cold With Power ON.

1. This procedure assumes line voltage, ECO and elements are in working order.
2. Turn power "ON" to water heater.
3. Set multi-meter to "Volts AC".
4. Check across terminals L4 and T2 of upper thermostat (see illustration 8).
 - A) Rated voltage NOT present, Recheck ECO. If ECO is okay, replace thermostat.
 - B) Rated voltage IS present, proceed to next step.
5. Check across element terminals (see illustration 9).
 - A) Rated voltage NOT present, check wire connections from thermostat to element.
 - B) Rated voltage IS present, Repeat element testing see page 15.

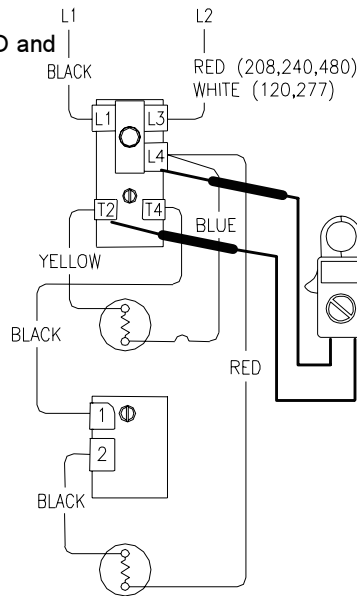

Illustration 8

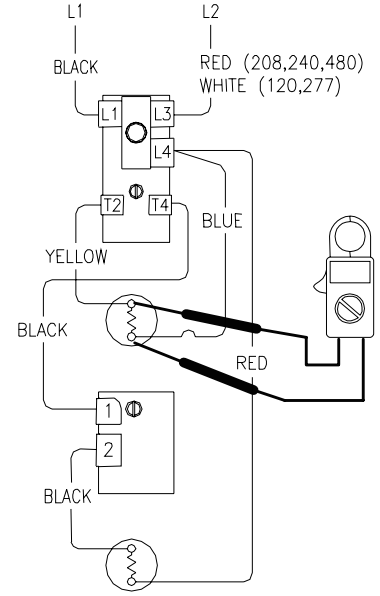

Illustration 9

Tank Does Not Deliver Enough Hot Water.

1. This procedure assumes line voltage, ECO and elements are in working order.
2. Turn power "ON" to water heater and set multi-meter to "Volts AC".
3. Adjust temperature setting of upper thermostat to the highest setting. Water temperature in tank must be below thermostat setting for this test.
4. See illustration 8 above, check voltage across terminals L4 and T2 of upper thermostat.
 - A) Rated voltage IS present, okay, upper thermostat is calling for heat. Go to step 5 below.
 - B) Rated voltage NOT present, replace upper thermostat.
5. Adjust temperature setting of upper thermostat to the minimum setting. Water temperature in tank must be above thermostat setting for this test.
6. Check voltage across terminals L4 and T4 of upper thermostat (see illustration 10).
 - A) Rated voltage NOT present, replace upper thermostat.
 - B) Rated voltage IS present, thermostat is okay. Go to step 7 on next page.

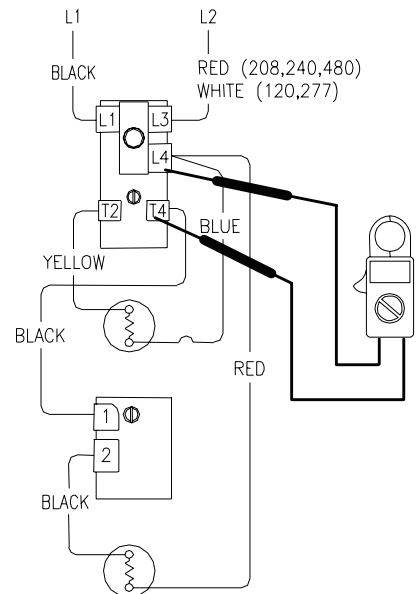

Illustration 10

Double Element, Non-Simultaneous, Single Phase Operation (continued).

Not Enough Hot Water (continued).

7. Check voltage across terminal L4 of upper thermostat and terminal 1 of lower thermostat (see illustration 11).
 - A) Rated voltage NOT present, - check wire connection between thermostats.
 - B) Rated voltage IS present, okay, go to step 8.
8. Adjust lower thermostat to highest setting. Water temperature in tank must be below the lower thermostat setting for this test.
9. Check voltage across terminal L4 of upper thermostat and terminal 2 of lower thermostat (see illustration 12).
 - A) Rated voltage NOT present, replace lower thermostat.
 - B) Rated voltage IS present, thermostat is ok.

⚠ WARNING
High voltage exposure. Use caution to avoid personal injury during this procedure.

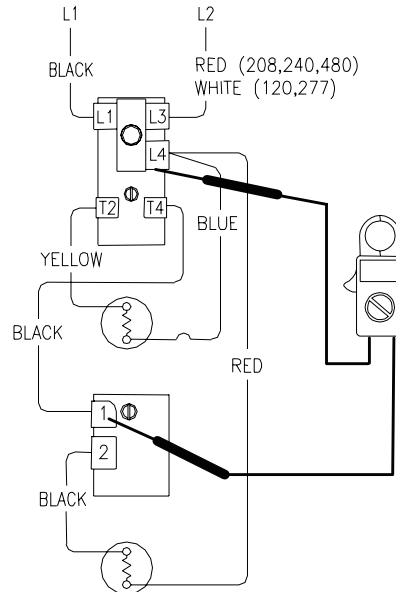

Illustration 11

⚠ WARNING
Be sure thermostats are reset to their original temperature settings as found prior to thermostat testing

Water Temperature In Tank Is Above Thermostat Setting.

1. This procedure assumes Line voltage, ECO and elements are in working order.
2. Adjust upper and lower thermostats to the lowest setting.
3. Turn power "ON" to water heater and set multi-meter to "Volts AC".
4. Check across terminals L4 and T2 of upper thermostat (see illustration 8 on page 17).
 - A) Rated voltage IS present, replace upper thermostat.
 - B) Rated voltage NOT present, upper thermostat is okay. Go to step 5 below.
 - C) Lower than rated voltage IS present, recheck for grounded upper element (see page 15).
5. Check across terminals L4 and 2 of lower thermostat (see illustration 12).
 - A) Rated voltage IS present, replace lower thermostat.
 - B) Rated voltage NOT present, lower thermostat is okay.
 - C) Lower than rated voltage IS present, recheck for grounded lower element (see page 15).

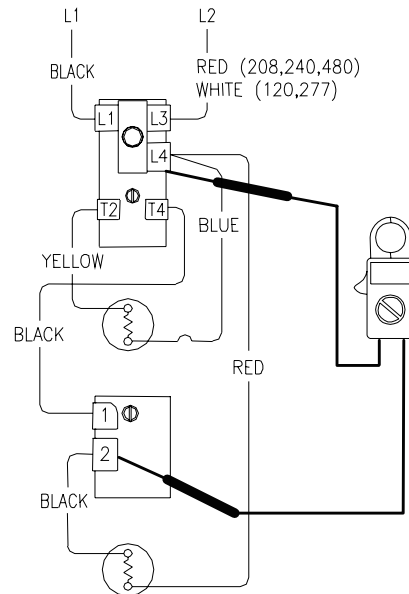

Illustration 12

Double Element, Non-Simultaneous, Three Phase Operation.

Water In Tank Is Cold With Power ON.

▲ WARNING
High voltage exposure. Use caution to avoid personal injury during this procedure.

1. This procedure assumes line voltage, ECO and elements are in working order.

2. Turn power "ON" to water heater.

3. Set multi-meter to "Volts AC".

4. Check across terminals L4 and T2 of upper thermostat (see illustration 13).

A) Rated voltage NOT present, Recheck ECO. If ECO is okay, replace thermostat.

B) Rated voltage IS present, proceed to next step.

5. Check across element terminals (see illustration 14).

A) Rated voltage NOT present, check wire connections from thermostat to element.

B) Rated voltage IS present, Repeat element testing, see page 15.

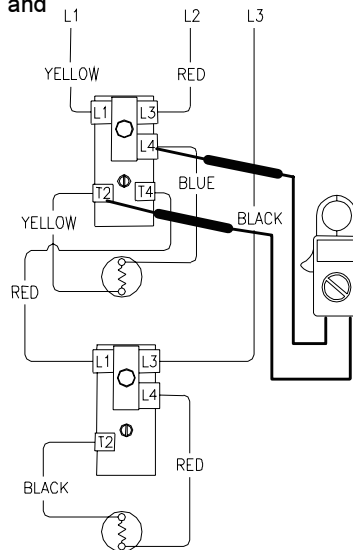

Illustration 13

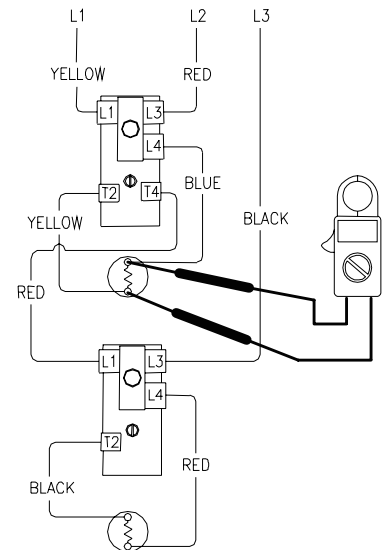

Illustration 14

Tank Does Not Deliver Enough Hot Water.

1. This procedure assumes line voltage, ECO and elements are in working order.

2. Turn power "ON" to water heater and set multi-meter to "Volts AC"

3. Adjust temperature setting of upper thermostat to the highest setting. Water temperature in tank must be below thermostat setting for this test.

4. See illustration 13 above, check voltage across terminals L4 & T2 of upper thermostat.

A) Rated voltage IS present, okay, upper thermostat is calling for heat. Go to step 5 below.

B) Rated voltage NOT present, replace upper thermostat.

5. Adjust temperature setting of upper thermostat to the minimum setting. Water temperature in tank must be above thermostat setting for this test.

6. Check voltage across terminals T4 of upper thermostat & L3 of lower thermostat (see illustration 15).

A) Rated voltage NOT present, replace upper thermostat.

B) Rated voltage IS present, upper thermostat is okay. Go to step 7 on next page.

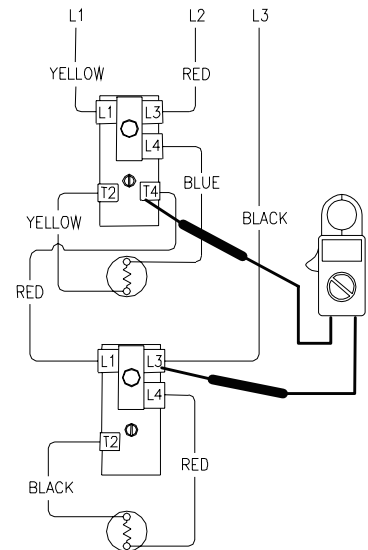

Illustration 15

**Double Element, Non-Simultaneous,
Three Phase Operation (continued).**

⚠ WARNING
**High voltage exposure. Use caution to avoid
personal injury during this procedure.**

Tank Does Not Deliver Enough Hot Water (continued)

7. Check voltage across terminal L1 & L3 of lower thermostat (see illustration 16).
 - A) Rated voltage NOT present, check wire connection between thermostats.
 - B) Rated voltage is present, okay, go to step 8.
8. Adjust lower thermostat to highest setting. Water temperature in tank must be below the lower thermostat setting for this test.
9. Check voltage across terminal L4 & T2 of lower thermostat (see illustration 17).
 - A) Rated voltage NOT present, recheck ECO (see page 14). If ECO okay, replace lower thermostat.
 - B) Rated voltage IS present, thermostat is ok. Check wire connection to lower element. If connection okay, recheck lower element (see page 15).

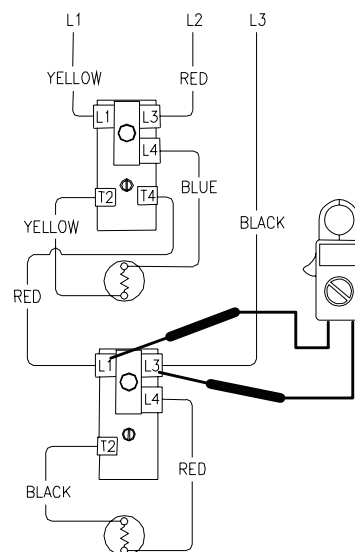

Illustration 16

⚠ WARNING
**Be sure thermostats are reset to their original
temperature settings as found prior to
thermostat testing**

Water Temperature In Tank Is Above Thermostat Setting.

1. This procedure assumes Line voltage, ECO and elements are in working order.
2. Adjust upper and lower thermostats to the lowest setting.
3. Turn power "ON" to water heater and set multi-meter to "Volts AC".
4. Check across terminals L4 and T2 of upper thermostat (see illustration 13 on page 19).
 - A) Rated voltage IS present, replace upper thermostat.
 - B) Rated voltage NOT present, upper thermostat is okay. Go to step 5 below.
 - C) Lower than rated voltage IS present, recheck for grounded upper element (see page 15).
5. Check across terminals L4 and T2 of lower thermostat (see illustration 17).
 - A) Rated voltage IS present, replace lower thermostat.
 - B) Rated voltage NOT present, lower thermostat is okay.
 - C) Lower than rated voltage IS present, recheck for grounded lower element (see page 15).

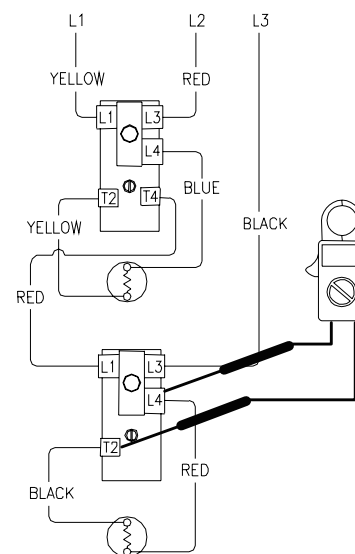

Illustration 17

Double Element, Simultaneous, Three Phase Operation.

⚠ WARNING
High voltage exposure. Use caution to avoid personal injury during this procedure.

Water In Tank Is Cold Or Not Enough Hot Water With Power ON.

1. This procedure assumes line voltage, ECO and elements are in working order.
2. Adjust temperature setting for both thermostats to the highest setting.
2. Turn power "ON" to water heater.
3. Set multi-meter to "Volts AC".
4. Check across terminals L4 and T2 of upper thermostat (see illustration 18).

- A) Rated voltage NOT present, Recheck ECO (see page 14). If ECO is okay, replace thermostat.
- B) Rated voltage IS present, proceed to next step.

5. Check across upper element terminals (see illustration 19).

- A) Rated voltage NOT present, check wire connections from thermostat to element.
- B) Rated voltage IS present, Repeat element testing see page 15.

6. Check across terminals L1 & L3 of lower thermostat (see illustration 20).

- A) Rated voltage NOT present, check wire connections from upper to lower thermostats.
- B) Rated voltage IS present, okay, go to step 7.

7. Check across terminals L4 and T2 of lower thermostat (see illustration 21).

- A) Rated voltage NOT present, Recheck ECO (see page 14). If ECO is okay, replace thermostat.
- B) Rated voltage IS present, proceed to next step.

8. Check across lower element terminals.

- A) Rated voltage NOT present, check wire connections from thermostat to element.
- B) Rated voltage IS present, Repeat element testing see page 15.

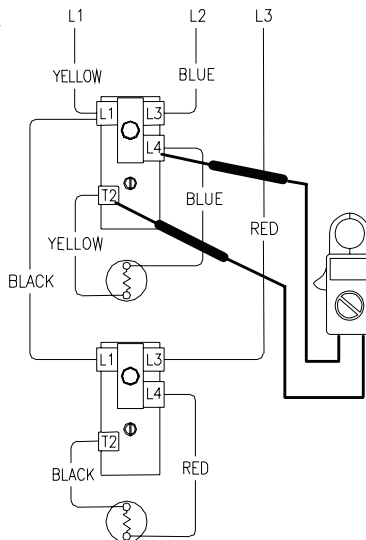

Illustration 18

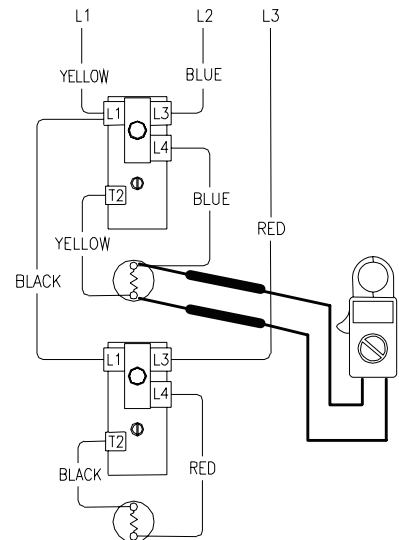

Illustration 19

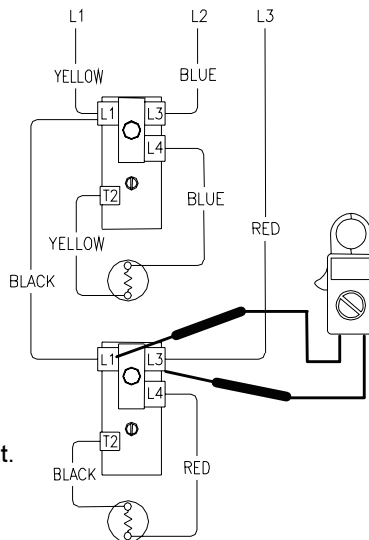

Illustration 20

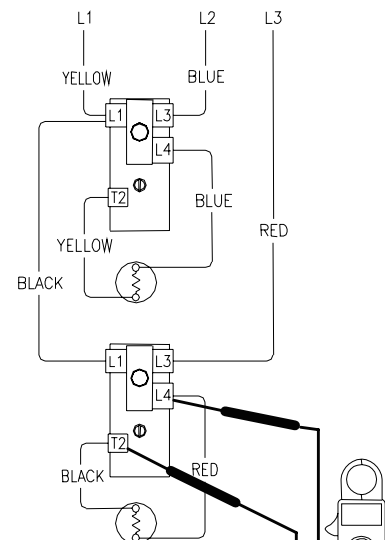

Illustration 21

⚠ WARNING
Be sure thermostats are reset to their original temperature settings as found prior to thermostat testing

Double Element, Simultaneous, Three Phase Operation (continued).

Water Temperature In Tank Is Above Thermostat Setting.

1. This procedure assumes Line voltage, ECO and elements are in working order.
2. Adjust upper and lower thermostat to the lowest setting.
3. Turn power "ON" to water heater.
4. Set multi-meter to "Volts AC".
5. Check across terminals L4 and T2 of upper thermostat (see illustration 22).
 - A) Rated voltage IS present, replace upper thermostat.
 - B) Rated voltage NOT present, upper thermostat is okay. Go to step 6 below.
 - C) Lower than rated voltage IS present, recheck for grounded upper element (see page 15).

⚠ WARNING
High voltage exposure. Use caution to avoid personal injury during this procedure.

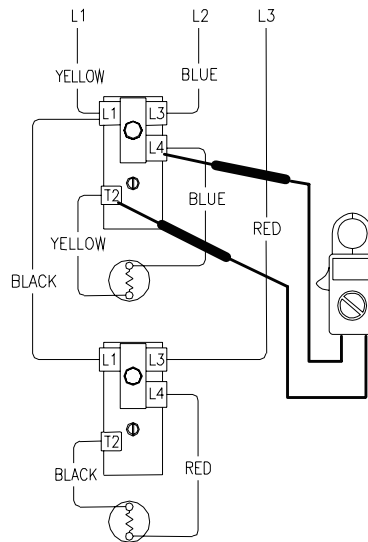

Illustration 22

6. Check across terminals L4 and T2 of lower thermostat (see illustration 23).
 - A) Rated voltage IS present, replace lower thermostat.
 - B) Rated voltage NOT present, lower thermostat is okay.
 - C) Lower than rated voltage IS present, recheck for grounded lower element (see page 15).

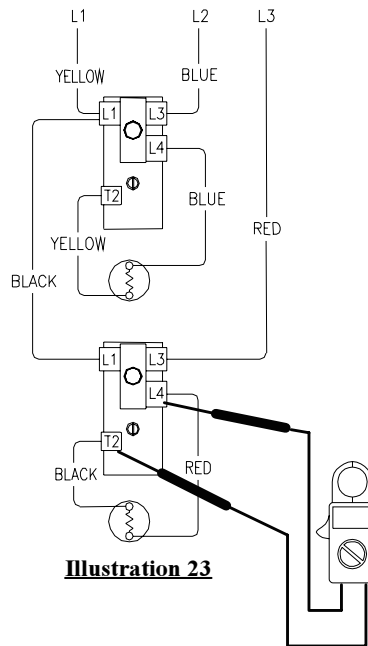

Illustration 23

Double Element, Non-Simultaneous, Single Phase, Off Peak Operation.

⚠ WARNING
High voltage exposure. Use caution to avoid personal injury during this procedure.

Water In Tank Is Cold With Power ON.

1. This procedure assumes line voltage, ECO and elements are in working order.
2. Turn power "ON" to water heater.
3. Set multi-meter to "Volts AC".
4. Check across terminals L4 and T2 of upper thermostat (see illustration 24).
 - A) Rated voltage NOT present, Recheck ECO (see page 14). If ECO is okay, replace thermostat.
 - B) Rated voltage IS present, proceed to next step.
5. Check across element terminals (see illustration 25).
 - A) Rated voltage NOT present, check wire connections from thermostat to element.
 - B) Rated voltage IS present, Repeat element testing see page 15.

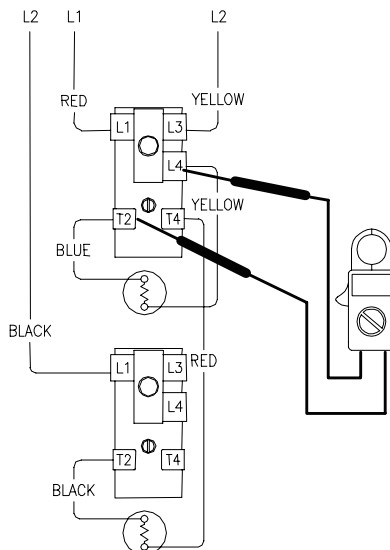

Illustration 24

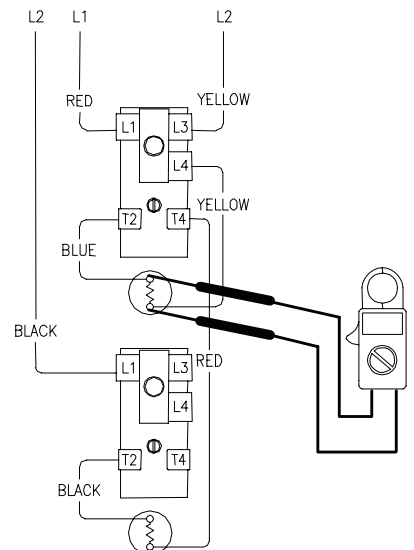

Illustration 25

Tank Does Not Deliver Enough Hot Water.

1. This procedure assumes line voltage, ECO and elements are in working order. Be sure OFF PEAK meter has not interrupted line voltage.
2. Turn power "ON" to water heater and set multi-meter to "Volts AC".
3. Adjust temperature setting of upper & lower thermostat to the Highest setting. Water temperature in tank must be below thermostat setting for this test.
4. See illustration 24 above. Check voltage across terminals L4 & T2 of upper thermostat.
 - A) Rated voltage IS present, okay, upper thermostat is calling for heat. Go to step 5 below.
 - B) Rated voltage NOT present, replace upper thermostat.
5. Adjust temperature setting of upper thermostat to the minimum setting. Water temperature in tank must be above thermostat setting for this test.
6. Check voltage across terminals T4 of upper thermostat & L1 of lower thermostat (see illustration 26).
 - A) Rated voltage NOT present, replace upper thermostat.
 - B) Rated voltage IS present, upper thermostat is okay. Go to step 7 on next page.

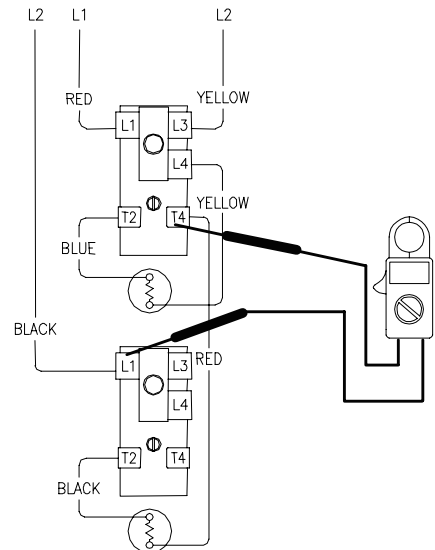

Illustration 26

**Double Element, Non-Simultaneous,
Single Phase, Off Peak Operation.**
(continued)

⚠ WARNING
**High voltage exposure. Use caution to avoid
personal injury during this procedure.**

Not Enough Hot Water (continued).

7. Check voltage across terminal T4 of upper thermostat & T2 of lower thermostat. (see illustration 27).

- A) Rated voltage NOT present, Replace lower thermostat.
- B) Rated voltage is present, okay, go to step 8.

8. Check voltage across lower element (see illustration 28).

- A) Rated voltage NOT present, Check wire connections between thermostats & element.
- B) Rated voltage IS present, Repeat element testing see page 15.

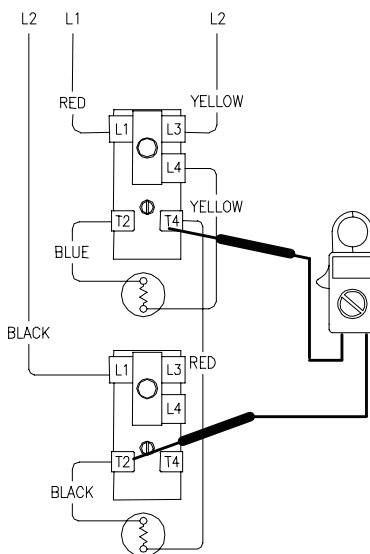

Illustration 27

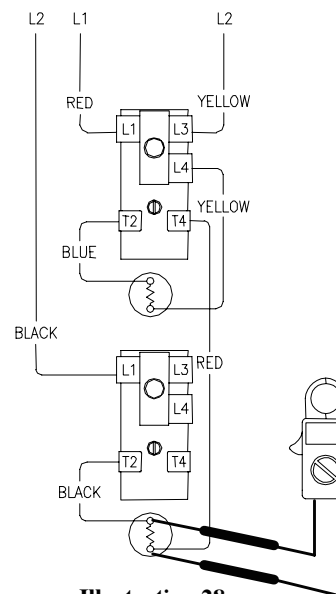

Illustration 28

⚠ WARNING
**Be sure thermostats are reset to their original
temperature settings as found prior to
thermostat testing**

Water Temperature In Tank Is Above Thermostat Setting.

1. This procedure assumes Line voltage, ECO and elements are in working order.
2. Adjust upper and lower thermostats to the lowest setting.
3. Turn power "ON" to water heater and set multi-meter to "Volts AC".
4. Check across terminals L4 and T2 of upper thermostat (see illustration 24 on page 23).
 - A) Rated voltage IS present, replace upper thermostat.
 - B) Rated voltage NOT present, upper thermostat is okay. Go to step 5 below.
 - C) Lower than rated voltage IS present, recheck for grounded upper element (see page 15).
5. Check across terminals T4 of upper thermostat and T2 of lower thermostat (see illustration 27 above).
 - A) Rated voltage IS present, replace lower thermostat.
 - B) Rated voltage NOT present, lower thermostat is okay.
 - C) Lower than rated voltage IS present, recheck for grounded lower element (see page 15).

Double Element, Non-Simultaneous, Single Phase Operation.

⚠ WARNING
High voltage exposure. Use caution to avoid personal injury during this procedure.

Water In Tank Is Cold With Power ON.

1. This procedure assumes line voltage, ECO and elements are in working order.
2. Turn power "ON" to water heater.
3. Set multi-meter to "Volts AC".
4. Check across terminals L4 and T2 of upper thermostat (see illustration 29).
 - A) Rated voltage NOT present, Recheck ECO (see page 14). If ECO is okay, replace thermostat.
 - B) Rated voltage IS present, proceed to next step.
5. Check across element terminals (see illustration 30).
 - A) Rated voltage NOT present, check wire connections from thermostat to element.
 - B) Rated voltage IS present, Repeat element testing see page 15.

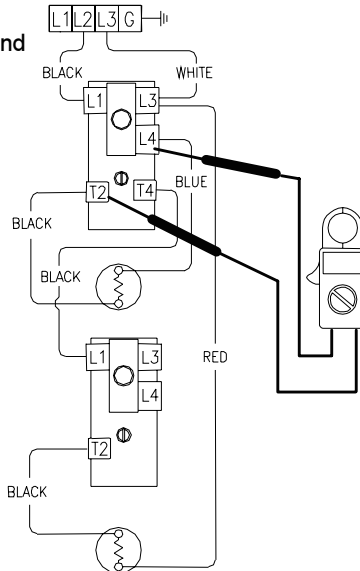

Illustration 29

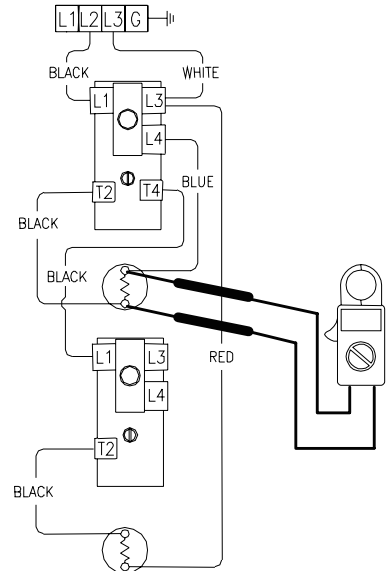

Illustration 30

Tank Does Not Deliver Enough Hot Water.

1. This procedure assumes line voltage, ECO and elements are in working order.
2. Turn power "ON" to water heater and set multi-meter to "Volts AC"
3. Adjust temperature setting of upper & lower thermostat to the Highest setting. Water temperature in tank must be below thermostat setting for this test.
4. See illustration 29 above. Check voltage across terminals L4 & T2 of upper thermostat.
 - A) Rated voltage IS present, okay, upper thermostat is calling for heat. Go to step 5 below.
 - B) Rated voltage NOT present, replace upper thermostat.
5. Adjust temperature setting of upper thermostat to the minimum setting. Water temperature in tank must be above thermostat setting for this test.
6. Check voltage across terminals L3 & T4 of upper thermostat (see illustration 31).
 - A) Rated voltage NOT present, replace upper thermostat.
 - B) Rated voltage IS present, upper thermostat is okay. Go to step 7 on next page.

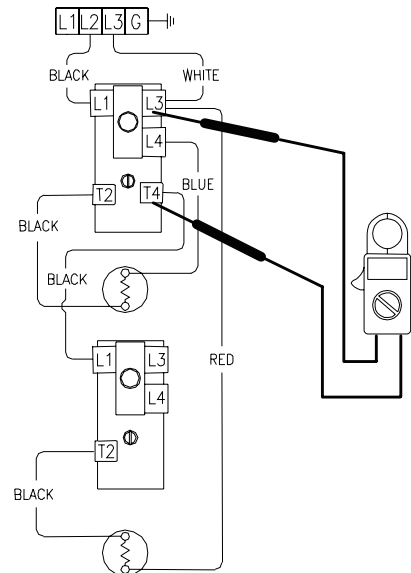

Illustration 31

**Double Element, Non-Simultaneous,
Single Phase Operation (continued)**

⚠ WARNING
**High voltage exposure. Use caution to avoid
personal injury during this procedure.**

**Tank Does Not Deliver Enough Hot
Water (continued).**

7. Check voltage across terminal L3 of upper thermostat & T2 of lower Thermostat. (see illustration 32).
 - A) Rated voltage NOT present, Replace lower thermostat.
 - B) Rated voltage is present, okay, go to step 8.
8. Check voltage across lower element (see illustration 33).
 - A) Rated voltage NOT present, Check wire connections between thermostats & element.
 - B) Rated voltage IS present, Repeat element testing see page 15.

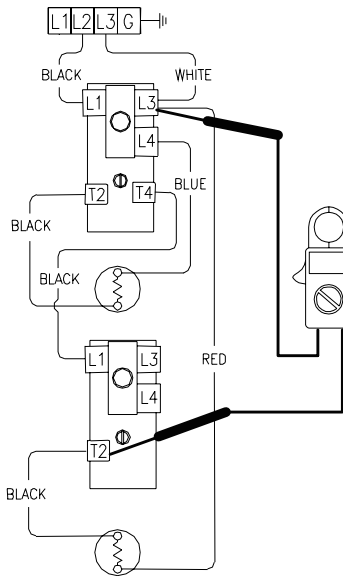

Illustration 32

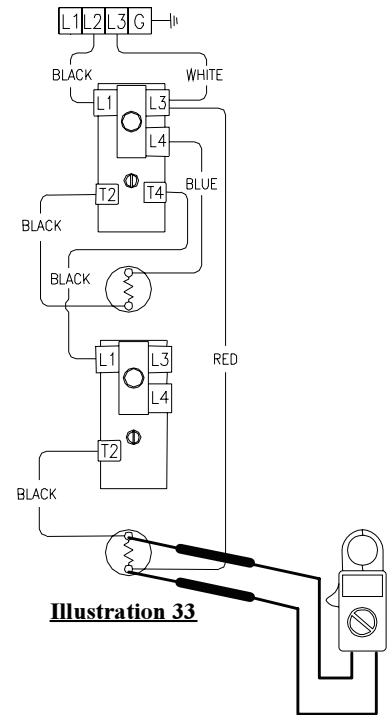

Illustration 33

⚠ WARNING
**Be sure thermostats are reset to
their original temperature settings
as found prior to thermostat
testing**

Water Temperature In Tank Is Above Thermostat Setting.

1. This procedure assumes line voltage, ECO and elements are in working order.
2. Adjust upper and lower thermostat to the lowest setting.
3. Turn power "ON" to water heater and Set multi-meter to "Volts AC"
4. See illustration 32 above. Check across terminal L3 of upper thermostat & T2 of lower thermostat.
 - A) Rated voltage IS present, replace lower thermostat.
 - B) Rated voltage NOT present, okay, go to step 5 below.
 - C) Lower than rated voltage IS present, recheck for grounded lower element see page 15.
5. Check across terminal L4 & T2 of upper thermostat (see illustration 34).
 - A) Rated voltage IS present, replace upper thermostat.
 - B) Rated voltage NOT present, upper thermostat is okay.
 - C) lower than rated voltage IS present, recheck for grounded upper element see page 15.

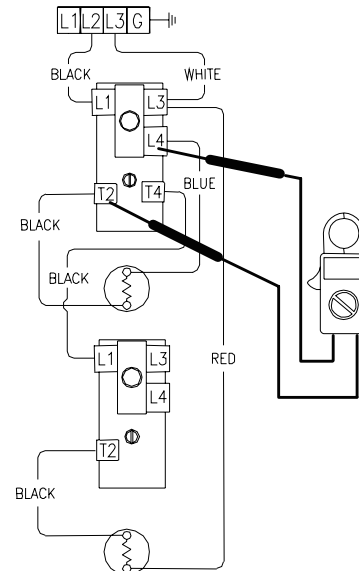

Illustration 34

Double Element, Simultaneous, Single Phase Operation.

⚠ WARNING
High voltage exposure. Use caution to avoid personal injury during this procedure.

Water In Tank Is Cold Or Not Enough Hot Water With Power ON.

1. This procedure assumes line voltage, ECO and elements are in working order.
2. Adjust temperature setting for both thermostats to the highest setting.
3. Turn power "ON" to water heater.
4. Set multi-meter to "Volts AC"
5. Check across terminals L4 and T2 of upper thermostat (see illustration 35).
 - A) Rated voltage NOT present, Recheck upper ECO (see page 14). If ECO is okay, replace upper thermostat.
 - B) Rated voltage IS present, proceed to next step.
6. Check across upper element terminals (see illustration 36).
 - A) Rated voltage NOT present, check wire connections from thermostat to upper element.
 - B) Rated voltage IS present, Repeat element testing see page 15.
7. Check across terminal L3 of upper thermostat and T2 of lower thermostat (see illustration 37).
 - A) Rated voltage NOT present, Check ECO (see page 14) & wire connections at upper & lower thermostats. If okay, replace lower thermostat.
 - B) Rated voltage IS present, proceed to next step.
8. Check across lower element terminals (see illustration 38).
 - A) Rated voltage NOT present, check lower element wire connections to the thermostats.
 - B) Rated voltage IS present, Repeat lower element testing see page 15

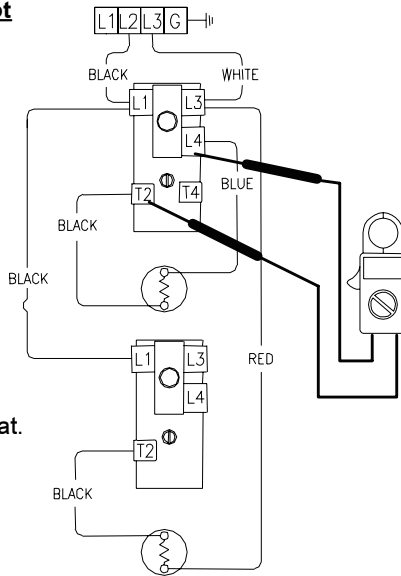

Illustration 35

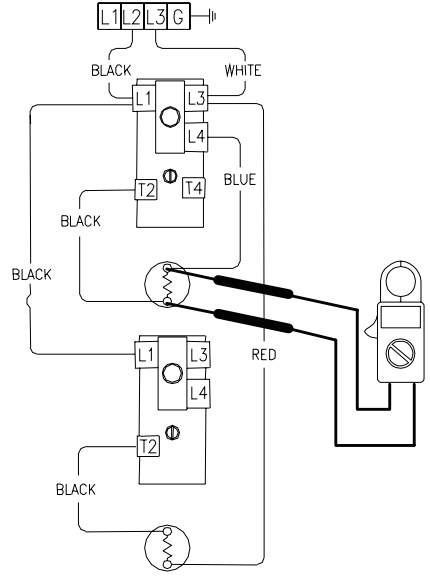

Illustration 36

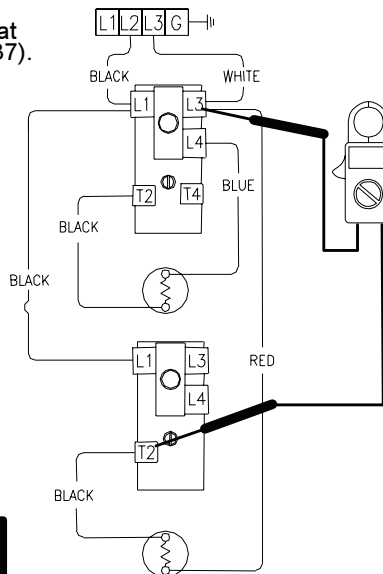

Illustration 37

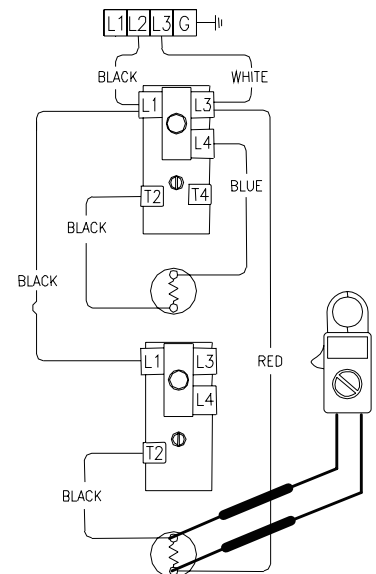

Illustration 38

⚠ WARNING
Be sure thermostats are reset to their original temperature settings as found prior to thermostat testing

Double Element, Simultaneous, Single Phase Operation (continued)

Water Temperature In Tank Is Above Thermostat Setting.

1. This procedure assumes line voltage, ECO and elements are in working order.
2. Adjust upper and lower thermostat to the lowest setting.
3. Turn power "ON" to water heater.
4. Set multi-meter to "Volts AC"
5. Check across terminals L4 and T2 of upper thermostat (see illustration 39).
 - A) Rated voltage IS present, replace upper thermostat.
 - B) Rated voltage NOT present, upper thermostat is okay. Go to step 6 below.
 - C) lower than rated voltage IS present, recheck for grounded upper element see page 15.
6. Check across terminal L3 of upper thermostat and T2 of lower thermostat (see illustration 40).
 - A) Rated voltage IS present, replace lower thermostat.
 - B) Rated voltage NOT present, lower thermostat is okay.
 - C) lower than rated voltage IS present, recheck for grounded lower element see page 15.

⚠ WARNING
High voltage exposure. Use caution to avoid personal injury during this procedure.

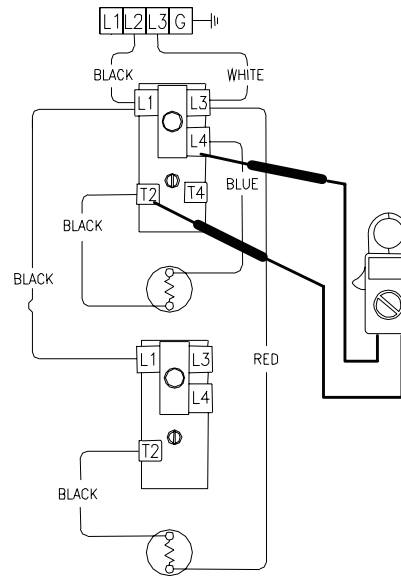

Illustration 39

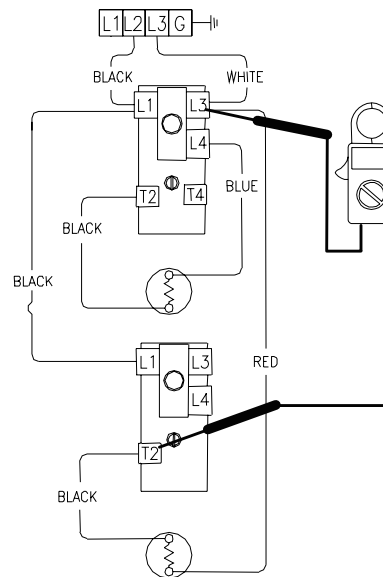

Illustration 40

Double Element, Non-Simultaneous, Three Phase Operation.

⚠ WARNING
High voltage exposure. Use caution to avoid personal injury during this procedure.

Water In Tank Is Cold With Power ON.

1. This procedure assumes line voltage, ECO and elements are in working order.
2. Turn power "ON" to water heater.
3. Set multi-meter to "Volts AC"
4. Check across terminals L4 and T2 of upper thermostat (see illustration 41).
 - A) Rated voltage NOT present, Recheck upper ECO. If ECO is okay, replace thermostat.
 - B) Rated voltage IS present, proceed to next step.
5. Check across element terminals (see illustration 42).
 - A) Rated voltage NOT present, check wire connections from thermostat to element.
 - B) Rated voltage IS present, Repeat element testing see page 15.

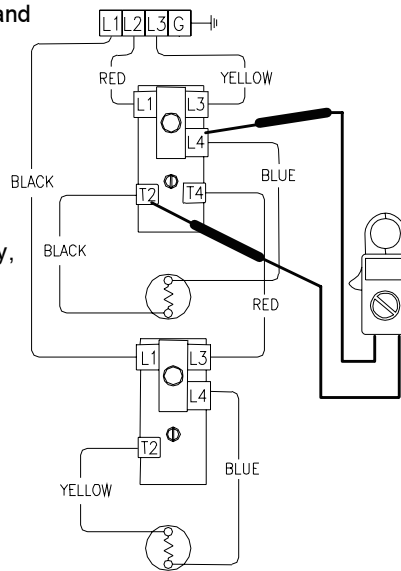

Illustration 41

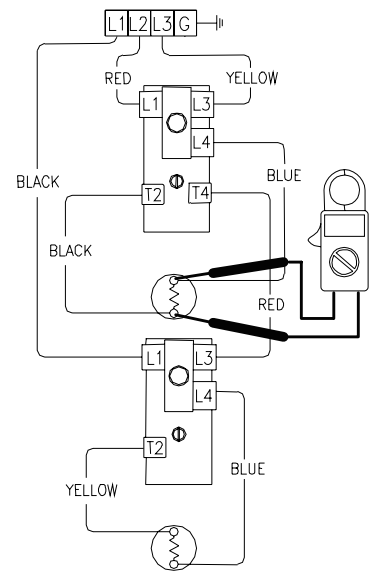

Illustration 42

Tank Does Not Deliver Enough Hot Water.

1. This procedure assumes line voltage, ECO and elements are in working order.
2. Turn power "ON" to water heater and set multi-meter to "Volts AC"
3. Adjust temperature setting of upper & lower thermostat to the Highest setting. Water temperature in tank must be below thermostat setting for this test.
4. See illustration 41 above. Check voltage across terminals L4 & T2 of upper thermostat.
 - A) Rated voltage IS present, okay, upper thermostat is calling for heat. Go to step 5 below.
 - B) Rated voltage NOT present, replace upper thermostat.
5. Adjust temperature setting of upper thermostat to the minimum setting. Water temperature in tank must be above thermostat setting for this test.
6. Check voltage across terminals L3 & T4 of upper thermostat (see illustration 43).
 - A) Rated voltage NOT present, replace upper thermostat.
 - B) Rated voltage IS present, upper thermostat is okay. Go to step 7 on next page.

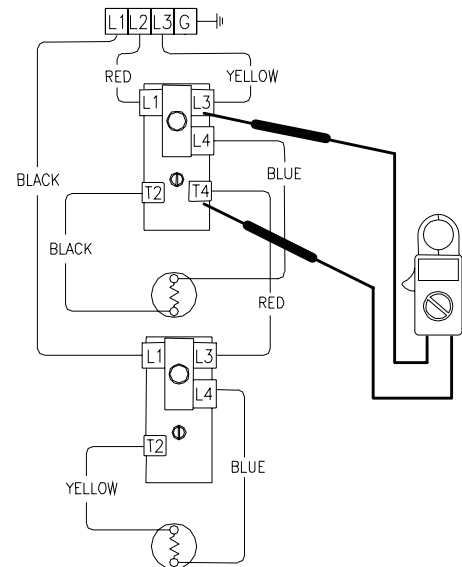

Illustration 43

**Double Element, Non-Simultaneous,
Three Phase Operation (continued).**

⚠ WARNING
**High voltage exposure. Use caution to avoid
personal injury during this procedure.**

**Tank Does Not Deliver Enough Hot Water
(continued).**

7. Check voltage across terminal L1 of upper thermostat & T2 of lower Thermostat. (see illustration 44).

- A) Rated voltage NOT present, Replace lower thermostat.
- B) Rated voltage is present, okay, go to step 8.

8. Check voltage across lower element (see illustration 45).

- A) Rated voltage NOT present, Check wire connections between thermostats & element.
- B) Rated voltage IS present, Repeat element testing see page 15.

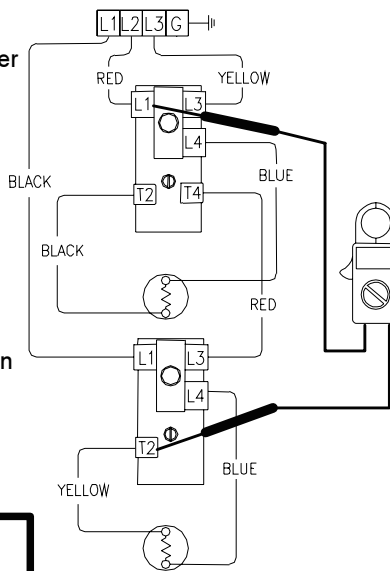

Illustration 44

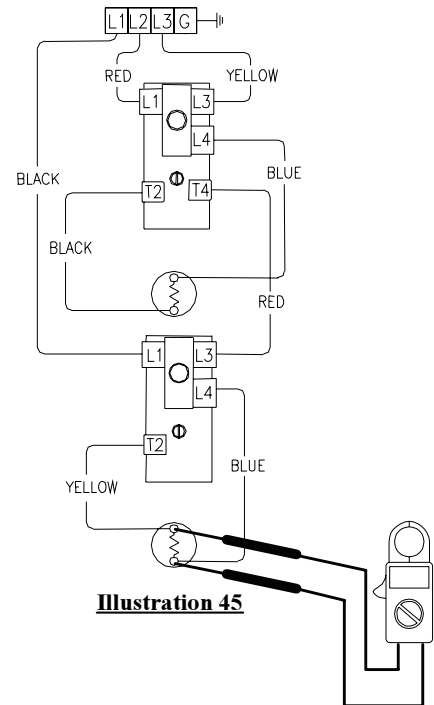

Illustration 45

⚠ WARNING
**Be sure thermostats are reset to
their original temperature settings
as found prior to thermostat
testing**

Water Temperature In Tank Is Above Thermostat Setting.

1. This procedure assumes line voltage, ECO and elements are in working order.

2. Adjust upper and lower thermostat to the lowest setting.

3. Turn power "ON" to water heater and Set multi-meter to "Volts AC".

4. See illustration 44 above. Check across terminal L1 of upper thermostat & T2 of lower thermostat.

- A) Rated voltage IS present, replace lower thermostat.
- B) Rated voltage NOT present, okay, go to step 5 below.
- C) lower than rated voltage IS present, recheck for grounded lower element.

5. Check across terminal L4 & T2 of upper thermostat (see illustration 46).

- A) Rated voltage IS present, replace upper thermostat.
- B) Rated voltage NOT present, upper thermostat is okay.
- C) lower than rated voltage IS present, recheck for grounded upper element, see page 15.

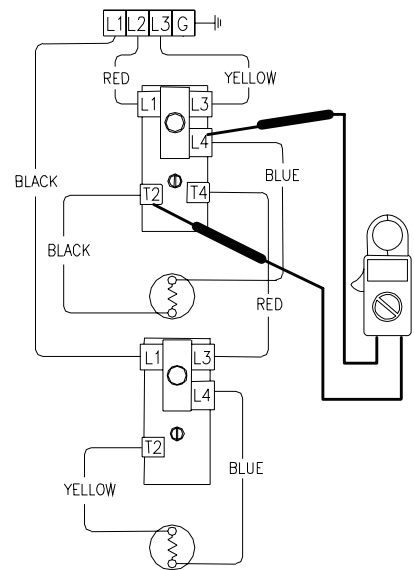

Illustration 46

Double Element, Simultaneous, Three Phase Operation.

⚠ WARNING
High voltage exposure. Use caution to avoid personal injury during this procedure.

Water In Tank Is Cold Or Not Enough Hot Water With Power ON.

1. This procedure assumes line voltage, ECO and elements are in working order.
2. Adjust temperature setting for both thermostats to the highest setting.
3. Turn power "ON" to water heater.
4. Set multi-meter to "Volts AC"
5. Check across terminals L4 and T2 of upper thermostat (see illustration 47).
 - A) Rated voltage NOT present, Recheck upper ECO (see page 14). If ECO is okay, replace upper thermostat.
 - B) Rated voltage IS present, proceed to next step.
6. Check across upper element terminals (see illustration 48).
 - A) Rated voltage NOT present, check wire connections from thermostat to upper element.
 - B) Rated voltage IS present, Repeat element testing see page 15

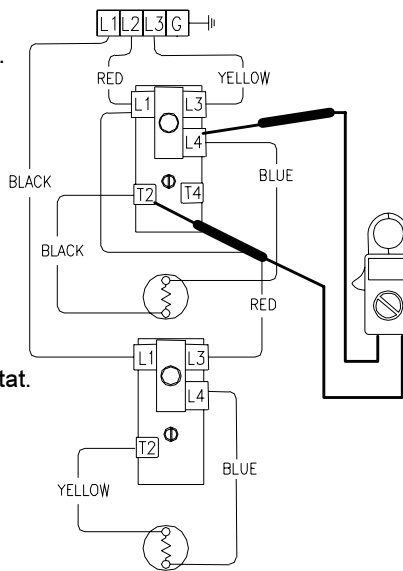

Illustration 47

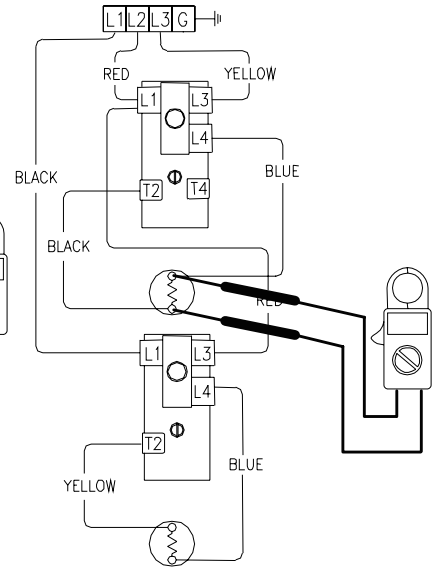

Illustration 48

7. Check across terminal L4 of upper thermostat and T2 of lower thermostat (see illustration 49).
 - A) Rated voltage NOT present, Check ECO (see page 14) & wire connections at upper & lower thermostats. If okay, replace lower thermostat.
 - B) Rated voltage IS present, proceed to next step.
8. Check across lower element terminals (see illustration 50).
 - A) Rated voltage NOT present, check lower element wire connections to thermostat.
 - B) Rated voltage IS present, Repeat lower element testing see page 15.

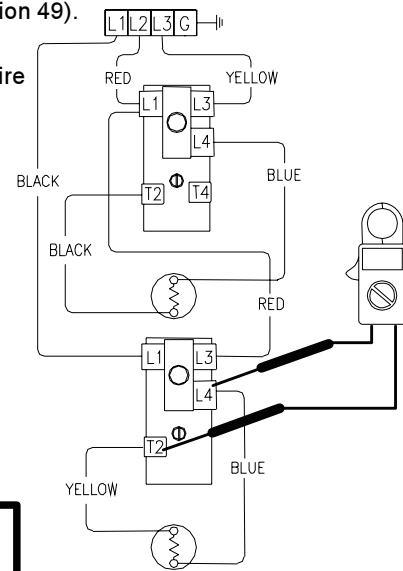

Illustration 49

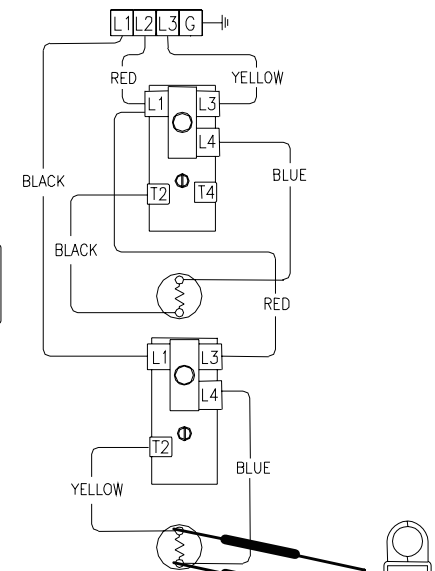

Illustration 50

⚠ WARNING
Be sure thermostats are reset to their original temperature settings as found prior to thermostat testing

Double Element, Simultaneous, Three Phase Operation (continued).

Water Temperature In Tank Is Above Thermostat Setting.

1. This procedure assumes line voltage, ECO and elements are in working order.
2. Adjust upper and lower thermostat to the lowest setting.
3. Turn power "ON" to water heater.
4. Set multi-meter to "Volts AC"
5. Check across terminals L4 and T2 of upper thermostat (see illustration 51).
 - A) Rated voltage IS present, replace upper thermostat.
 - B) Rated voltage NOT present, upper thermostat is okay. Go to step 6 below.
 - C) lower than rated voltage IS present, recheck for grounded upper element see page 15.
6. Check across terminals L4 & T2 of lower thermostat (see illustration 52).
 - A) Rated voltage IS present, replace lower thermostat.
 - B) Rated voltage NOT present, lower thermostat is okay.
 - C) lower than rated voltage IS present, recheck for grounded lower element.

⚠ WARNING
High voltage exposure. Use caution to avoid personal injury during this procedure.

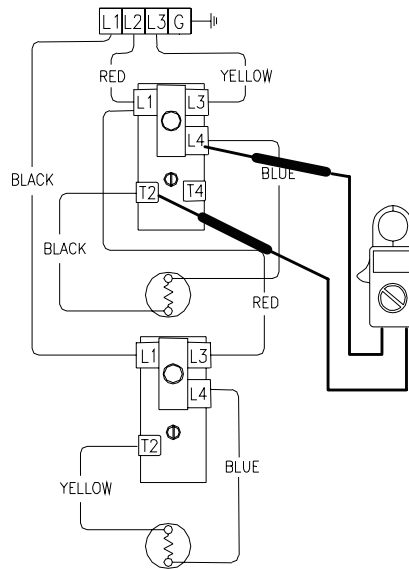

Illustration 51

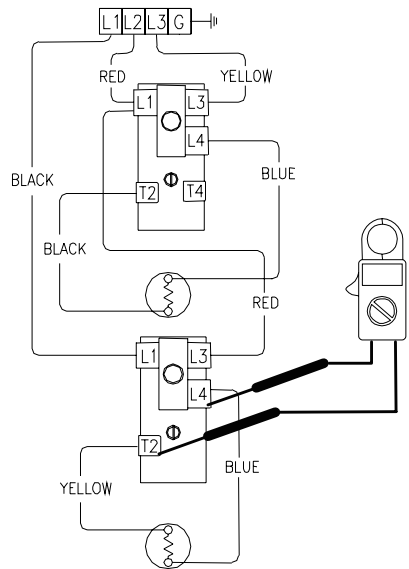

Illustration 52

Thermostat Removal

1. Turn power "OFF" To water heater.
2. Remove access cover and insulation.
3. Remove plastic thermostat protector from thermostat.
4. Disconnect wires from thermostat terminals. It may be necessary to label wires for proper re-connection to new thermostat.
5. Note thermostat temperature setting for proper setting of new thermostat.
6. Slide thermostat upwards and out of mounting bracket.

⚠ WARNING
High voltage exposure. Be sure power is "OFF" when performing this procedure.

Thermostat Replacement

1. Use a stiff brush to remove any debris or loose scale from tank surface where new thermostat will be installed.
2. Slide new thermostat down into thermostat bracket until it snaps into place. **IMPORTANT!** Thermostat must set completely flat or flush to tank surface. An improperly installed thermostat will cause improper water heater operation.
3. Refer to the wire diagram located on the inside of the access cover and re-connect wires to the thermostat. Be sure wire connections are snug and corrosion free. Do not over tighten, doing so may damage thermostat.
4. Set thermostat to the original thermostat setting found on the old thermostat.
5. Re-install plastic thermostat protector.
6. Re-install insulation and access cover.
7. Restore power to water heater and verify proper heater operation.

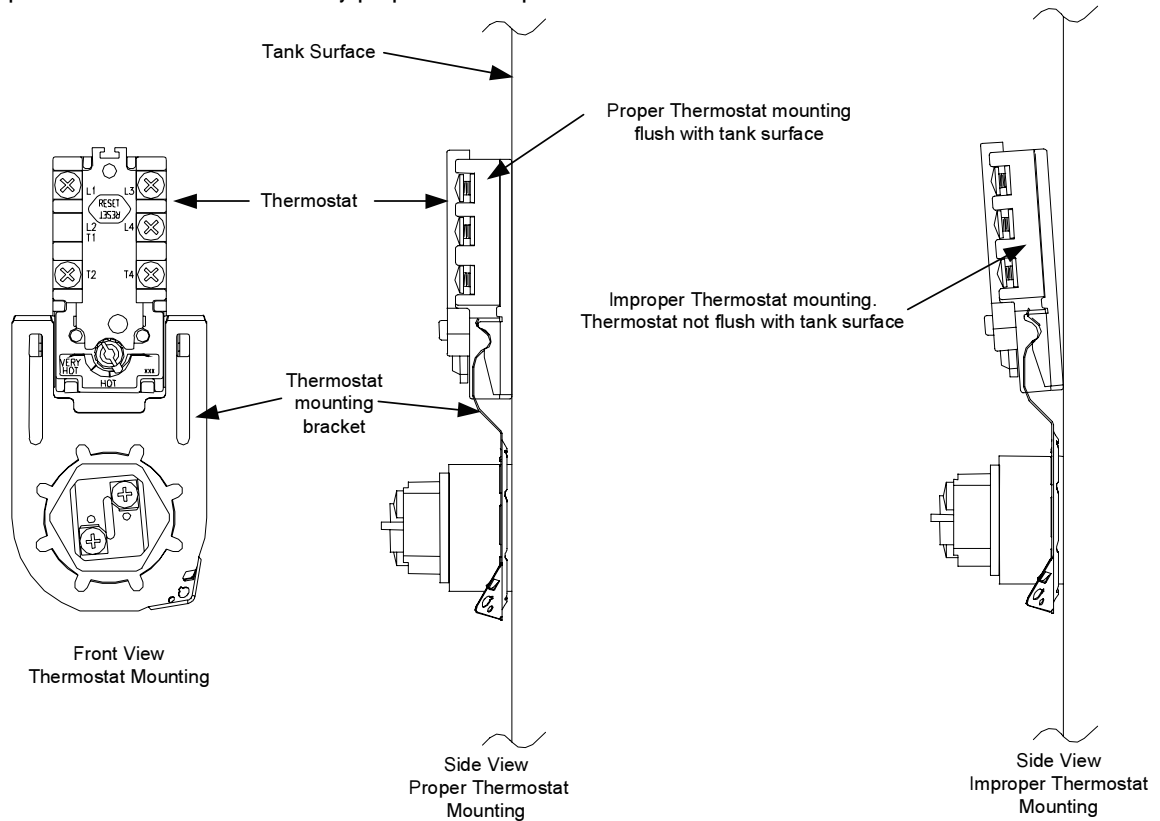

Heating Element Removal

1. Turn power "OFF" To water heater.
2. Turn off cold water supply to heater. Connect hose to drain spigot of water heater and route to an open drain. Open a nearby hot water faucet to vent heater for draining. Open drain spigot of water heater and allow heater to drain to a point below the Element(s).
3. Close drain spigot and remove hose.
4. Remove access cover and insulation.
5. Remove plastic thermostat protector from thermostat.
6. Disconnect wires from element terminals.
7. Remove element from tank using 1-½ deep well socket or appropriate wrench. Unscrew element counter-clockwise to remove from tank.
8. Be sure to remove old element gasket from the tank. It is not recommended to be re-used.

WARNING
High voltage exposure. Be sure power is "OFF" when performing this procedure.

WARNING
Heater components and stored water may be **HOT** when performing the following steps in this procedure. Take necessary precaution to prevent personal injury.

Heating Element Replacement

1. Check element terminal block for proper electrical rating. NOTE: Some elements have dual ratings, be sure to check all surfaces of the element terminal block (see illustration below).
2. Apply new element gasket to the new element. Be sure gasket is seated flat against element flange without rolls or gaps (see illustration below).
3. Clean any debris from element fitting on tank. Lubricate element threads as needed with thread lubricant.
4. Thread new element clockwise into tank. Tighten element using 1-½ deep well socket or appropriate wrench. Do not over tighten, over tightening may damage element gasket.
5. Reconnect wires to element, be sure wires are snug and corrosion free. Do not over tighten, doing so may damage terminal block.
6. Resume water supply to heater, be sure tank is full of water and check for leaks.
7. Re-install plastic thermostat protector.
8. Re-install insulation and access cover.
9. To resume operation, **BE SURE TANK IS FULL OF WATER** and restore power to water heater. Verify proper heater operation.

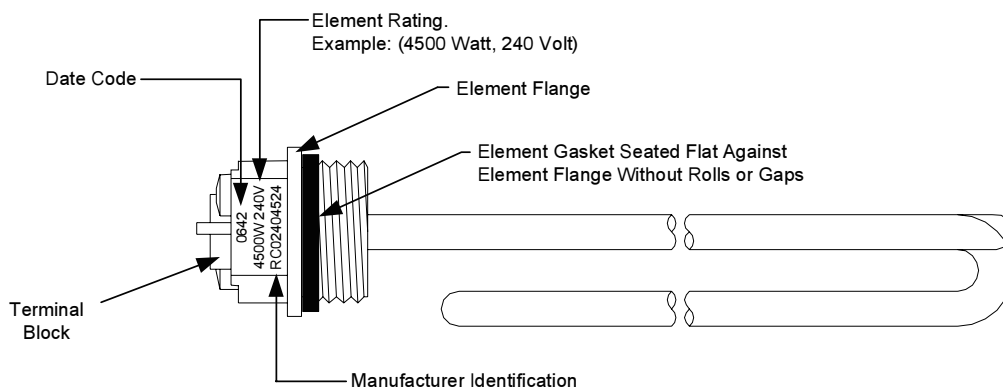

Dip Tube Inspection and Replacement

WARNING

Heater components and stored water may be **HOT** when performing the following steps in this procedure. Take necessary precaution to prevent personal injury.

- Step 1. Turn power "OFF" to water heater.
- Step 2. Turn off cold water supply to heater. Connect hose to drain spigot of water heater and route to an open drain. Open a nearby hot water faucet to vent heater for draining. Open drain spigot of water heater and allow heater to drain to a point below the inlet connection nipple.
- Step 3. Close drain spigot and remove hose.
- Step 4. Disconnect inlet nipple from plumbing system.
- Step 5. With an appropriate wrench, remove inlet nipple/dip tube from the water heater. Use caution not to damage nipple threads.
- Step 6. Visually Inspect inlet nipple/dip tube. Inlet nipple/dip tube should be free of cracks and any blockage. Hydro-jets located near the bottom of the dip tube should be open and free of any blockage. Anti-siphon hole located approximately 6" from the bottom of nipple, should be free of any blockage.

Any damage such as cracks, restriction due to deformation or unintentional holes are not field repairable and the inlet nipple/dip tube must be replaced.
- Step 7. Upon completion of inspection or subsequent replacement, reinstall inlet nipple/dip tube into heater. Connect nipple to plumbing system, close spigot and remove drain hose, resume water supply and refill heater with water.
- Step 8. To resume operation, **BE SURE TANK IS FULL OF WATER** and turn power "ON" to water heater.

Anode Inspection and Replacement

- Step 1. Turn power "OFF" to water heater.
- Step 2. Turn off cold water supply to heater. Connect hose to drain spigot of water heater and route to an open drain. Open a nearby hot water faucet to vent heater for draining. Open drain spigot of water heater and allow heater to drain to a point below the outlet connection nipple.
- Step 3. Close drain spigot and remove hose.
- Step 4. Disconnect outlet nipple from plumbing system.
- Step 5. With an appropriate wrench, remove outlet nipple/anode from the water heater. Use caution not to damage nipple threads.
- Step 6. Visually Inspect outlet nipple/anode. Outlet nipple/anode should show signs of depletion, this is normal. If depletion is $\frac{1}{2}$ of the original anode diameter (original diameter approximately $\frac{3}{4}$ "), replacement is recommended. If any of the steel core of the anode is exposed, replacement is recommended.
- Step 7. Upon completion of inspection or subsequent replacement, reinstall outlet nipple/anode into heater. Connect nipple to plumbing system, close spigot and remove drain hose, resume water supply and refill heater with water.
- Step 8. To resume operation, **BE SURE HEATER IS FULL OF WATER** and turn power "ON" to water heater.

TOP LOCATION

- Double element water heater, non-simultaneous single phase and three phase operation.

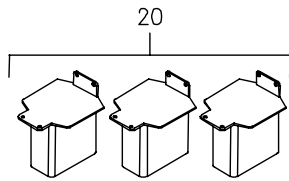
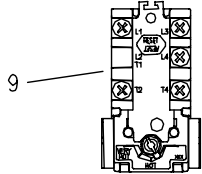

TOP LOCATION

- Double element water heater, simultaneous operation.

BOTTOM LOCATION

- Single element water heater.
- Double element water heater, non-simultaneous three phase operation.
- Double element water heater, simultaneous operation.

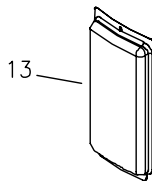
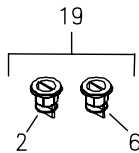
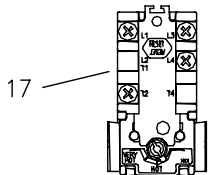

BOTTOM LOCATION

- Double element water heater, non-simultaneous single phase operation

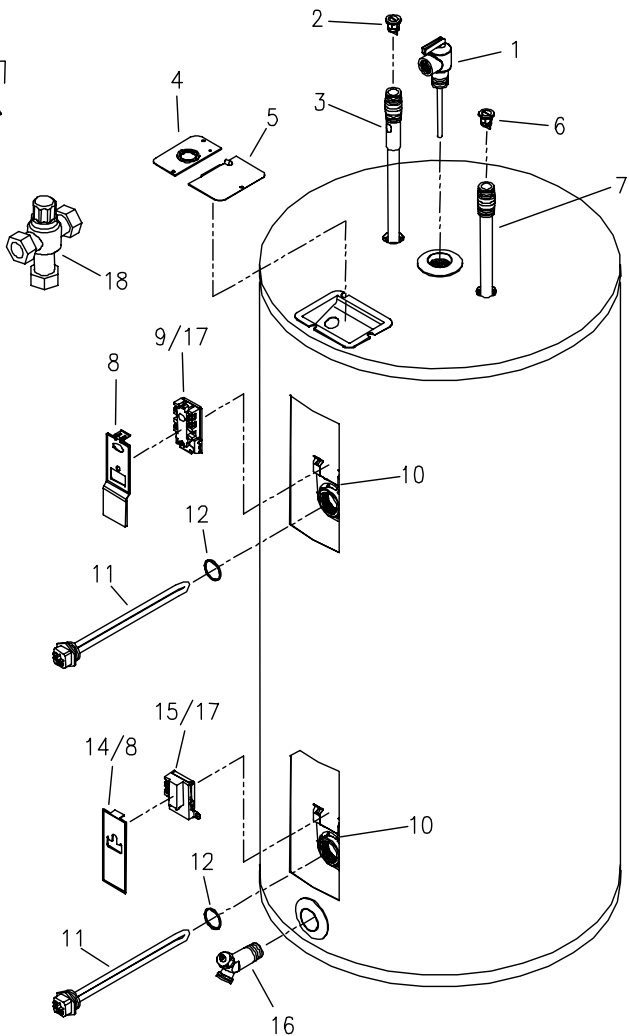
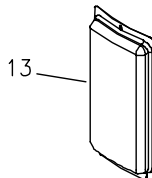
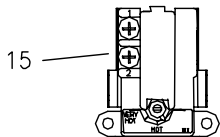

- 1. T&P Relief Valve
- 2. Heat Trap Insert (Outlet)
- 3. Hot Water Outlet/Anode
- 4. Cover Conduit/Ground
- 5. Junction Box Cover
- 6. Heat Trap Insert (Inlet)
- 7. Cold Water Inlet Dip Tube
- 8. Thermostat Protector (Large)
- 9. Thermostat w/High Limit (89T33)
- 10. Thermostat Mounting Bracket

- 11. Heating Element
- 12. Element Gasket
- 13. Access Cover
- 14. Lower Thermostat Protector (Small)
- 15. Thermostat (59T)
- 16. Brass Drain Valve
- 17. Thermostat w/High Limit (89T13)
- 18. ASSE Approved Mixing Device
- 19. Kit Heat Trap
- 20. Kit Dairy Barn Leg

NOTES



Ambler, PA

For U.S. and Canada field service,
contact your professional installer or
local Bradford White sales representative.

Sales/800-523-2931
Fax/215-641-1670
Parts Fax/215-641-2180

Technical Support/800-334-3393
Fax/269-795-1089

Warranty/800-531-2111
Fax/269-795-1089

International:
Telephone/215-641-9400
Telefax/215-641-9750



Sales/866-690-0961
905-238-0100

Fax/905-238-0105

Technical Support/800-334-3393

Email

parts@bradfordwhite.com
techserv@bradfordwhite.com

www.bradfordwhite.com