

# INSTALLATION INSTRUCTIONS

## LF24

30,000 to 75,000 Btuh Series

### UNIT HEATERS

506681-01  
5/2011  
Supersedes 503,526M

### Table Of Contents

Unit Dimensions . . . . .	1	Unit Start-Up . . . . .	11
Shipping . . . . .	1	To Turn Off Gas to Unit . . . . .	12
Optional Accessory . . . . .	1	Heating Sequence of Operations . . . . .	12
CSA Requirements in USA . . . . .	1	Ignition Control LED . . . . .	13
CSA Requirements in Canada . . . . .	2	High Altitude Adjustments . . . . .	13
Additional Requirements . . . . .	3	Gas Flow . . . . .	13
Unit Heater Installation . . . . .	3	Gas Pressure Adjustments . . . . .	13
Combustion and Ventilation Air . . . . .	3	Limit Control . . . . .	14
Venting . . . . .	3	Louver Vane Adjustment . . . . .	14
Electrical Connections . . . . .	9	Combustion Air Pressure Switch . . . . .	14
Typical Wiring Diagram . . . . .	10	Flame Rollout Switch . . . . .	14
Gas Connection . . . . .	10	Service . . . . .	14
Leak Check . . . . .	11	Start-Up and Performance Checklist . . . . .	15

**RETAIN THESE INSTRUCTIONS  
FOR FUTURE REFERENCE**

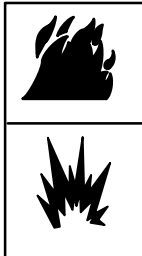

### **⚠ WARNING**

#### **FIRE OR EXPLOSION HAZARD.**

**Failure to follow safety warnings exactly could result in serious injury, death, or property damage.**



Be sure to read and understand the installation, operation and service instructions in this manual.

Improper installation, adjustment, alteration, service or maintenance can cause serious injury, death or property damage.

Do not store or use gasoline or other flammable vapors and liquids in the vicinity of this or any other appliance.

Installation and service must be performed by a qualified installer, service agency or the gas supplier.

### **WHAT TO DO IF YOU SMELL GAS:**

- Do not try to light any appliance.
- Do not touch any electrical switch; do not use any phone in your building.
- Leave the building immediately.
- Immediately call your gas supplier from a neighbor's phone. Follow the gas supplier's instructions.
- If you cannot reach your gas supplier, call the fire department.



## LF24-30, 45, 60, & 75 UNIT DIMENSIONS (NATURAL GAS & PROPANE)

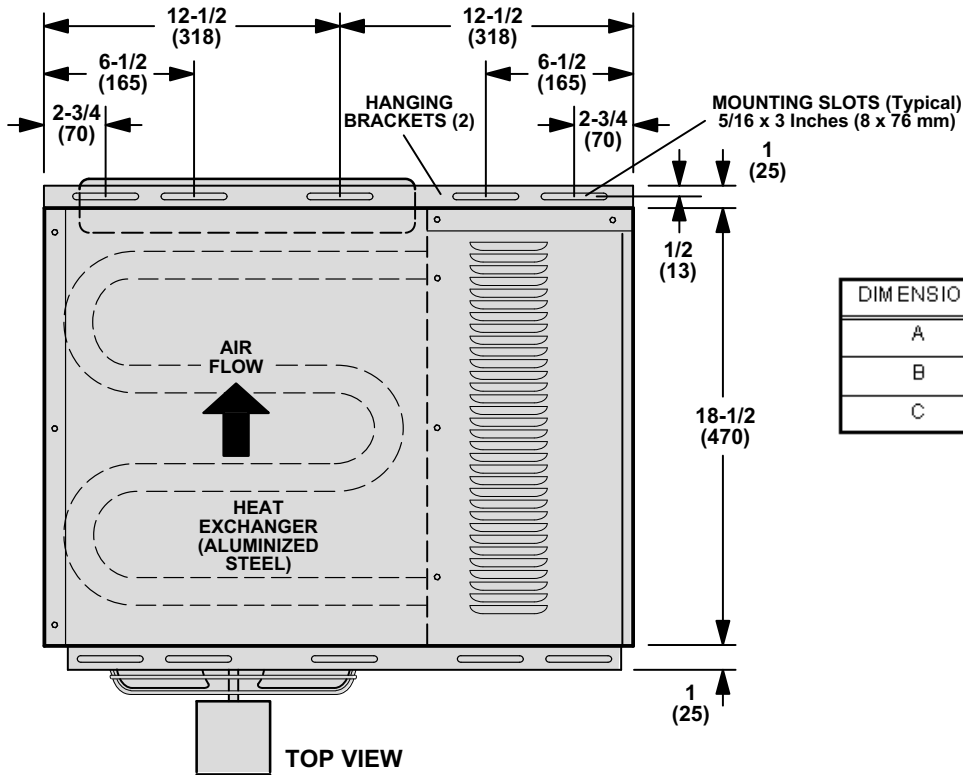

DIMENSION	30/45	60/75
A	12 (305)	17 (432)
B	5-1/2 (140)	6-1/2 (165)
C	4-1/4 (108)	6-3/4 (171)

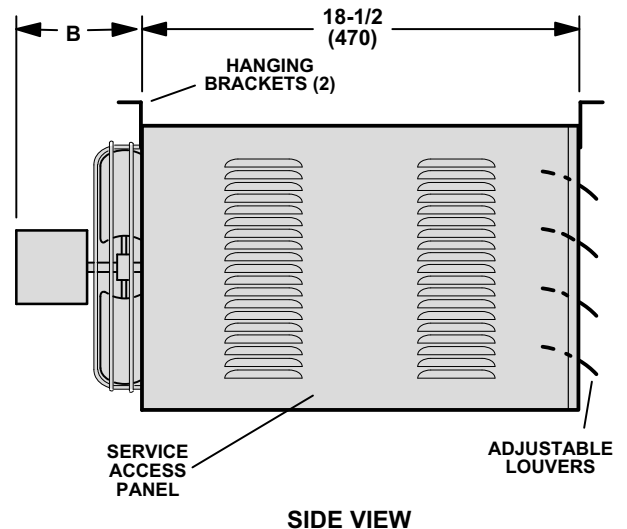
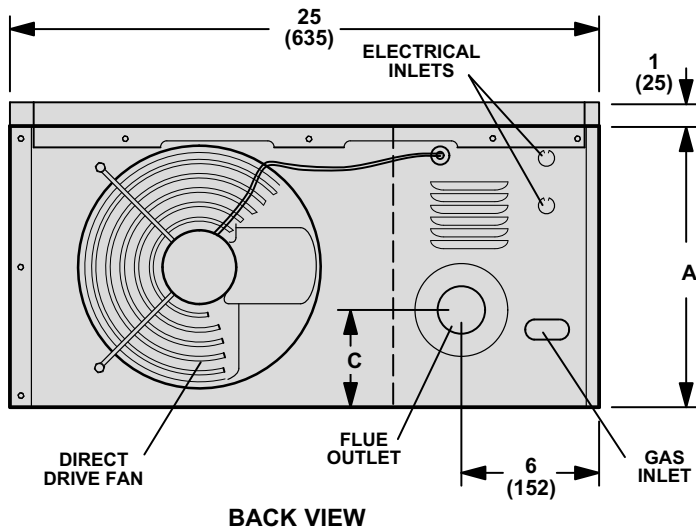

### Shipping

Shipping contents includes heater, installation instructions, warranty certificate, two mounting brackets (shipped loose), and a flue transition. The heater is shipped completely assembled. Check the unit for shipping damage. The receiving party should contact the last carrier immediately if any shipping damage is found.

### Optional Accessory

LF24-30, 45, 60 and 75 units require a changeover kit (20L05) when the unit is to be used with LP/propane gas. The kit is ordered separately.

### CSA Requirements in USA

Installation of gas unit heaters must conform with local building codes or, in the absence of local codes, with the current edition of ANSI Z223.1, National Fuel Gas Code.

Installation in aircraft hangers must be in accordance with the current edition of ANSI/NFPA No. 409, Standard for Aircraft Hangers.

Installation in parking structures must be in accordance with the current edition of ANSI/NFPA No. 88A, Standard for Parking Structures.

Installation in repair garages must be in accordance with the current edition of ANSI/NFPA No. 88B, Standard for Repair Garages.

These units are approved for residential garage or non-confined living space applications. For installation in a residential garage or non-confined living space, unit must be installed so that burners and ignition source are located no less than 18" (457mm) above floor. Heater must be located or protected to avoid physical damage by vehicles. Refer to the current edition of ANSI Z223.1, National Fuel Gas Code.

Authorities having jurisdiction should be consulted before installation. Air for combustion and ventilation must conform to the methods outlined in the current edition of ANSI Z223.1, Section 5.3, Air for Combustion and Ventilation, or applicable provisions of local building codes.

The National Fuel Gas Code (ANSI Z223.1) is available from:

American National Standard Institute Inc.  
11 West 42nd Street  
New York, NY 10036

These unit heaters are CSA International design-certified. These unit heaters are certified for installation to combustible material as listed in *Table 1* and on unit rating plate.

Accessibility and service clearances must be observed in addition to fire protection clearances.

All electrical wiring and grounding for unit must be in accordance with the regulations of the current edition of ANSI/NFPA No. 70, National Electric Code.

The National Electric Code is available from:

National Fire Protection Association  
1 Batterymarch Park  
PO Box 9101  
Quincy, MA 02269-9101

### CSA Requirements in Canada

These instructions are intended only as a general guide and do not supersede local codes in any way. Authorities having jurisdiction should be consulted before installation. The installation must conform with local building codes or, in the absence of local codes, with the

current edition of CSA-B149 installation compliance codes. All electrical wiring and grounding for the unit must also comply with the current edition of CSA C22.1, Canadian Electrical Code.

These unit heaters are CSA-certified for the installation clearances listed on the rating plate and in table 1. Adequate clearance must be provided around the appliance and around air openings into the combustion chamber. Provision shall be made for service accessibility.

**NOTE** - Fire protection clearances may be exceeded to provide additional space for service and accessibility.

### GARAGE / WAREHOUSE INSTALLATIONS

- 1 - In a storage area, clearance from heaters to combustible materials must be such that the combustible material must not attain a temperature above 160°F (71°C) by continuous operation of the unit.

## ⚠ WARNING

**Combustible materials that are affected by exposure to temperatures LESS than 160°F (plastics, plastic wrap, styrofoam, cardboard, etc.) must be stored well away from this heater. Discharge air temperatures for these units can approach 200°F.**

- 2 - Maintain an 8-foot (2m) minimum clearance from the floor to the bottom of the heater. Refer to the current edition of CSA-B149 for installation compliance codes.

### AIRCRAFT HANGER

- 1 - In an area where aircraft are housed or serviced, a 10-foot (3m) minimum clearance from the highest surface of the aircraft to bottom of the heater must be maintained.
- 2 - In other areas, an 8-foot (2m) minimum clearance from the floor to bottom of heater must be maintained.
- 3 - Heaters should be located so that they are protected from damage from aircraft or other appliances needed for servicing of aircraft. Refer to requirements of the enforcing authorities.

### RESIDENTIAL

These units are approved for residential garage or non-confined living space applications. For installation in a residential garage or non-confined living space, unit must be installed so that burners and ignition source are

located no less than 18" (457mm) above floor. Heater must be located or protected to avoid physical damage by vehicles. Refer to the current edition of CSA-B149 for installation compliance codes.

In a confined area, the heater must be installed in accordance with the current edition of CSA-B149 installation compliance codes. Be sure to check with local codes and ordinances for additional requirements.

**Additional Requirements**

The Commonwealth of Massachusetts stipulates the following additional requirements:

- 1 - Gas furnaces shall be installed by a licensed plumber or gas fitter only.
- 2 - The gas cock must be "T handle" type.

**Unit Heater Installation**

**⚠ WARNING**

Improper installation, adjustment, alteration, service or maintenance can cause property damage, personal injury or loss of life. Installation and service must be performed by a licensed professional installer (or equivalent), service agency or the gas supplier.

**⚠ CAUTION**

As with any mechanical equipment, personal injury can result from contact with sharp sheet metal edges. Be careful when you handle this equipment.

The appliance shall not be installed downstream from evaporator coils or cooling units.

Unit is shipped ready for installation. Unit may be installed as shown in figure 1 or rotated 180° depending on desired location as governed by clearances, vent connection, air direction, gas supply, electrical supply and service accessibility.

- 1 - *If installing unit in a rotated position --*  
Remove and retain screws securing door and rotate door 180°. Resecure door using existing screws. Rotate louvers to direct airflow as desired.
- 2 - Choose location for mounting brackets.

- 3 - Remove and retain three screws along top edge (bottom edge when inverted) of front of unit.
- 4 - Align screw holes on mounting bracket with holes along top edge (either upright or inverted) of unit. Use existing screws to secure one mounting bracket to front of unit. Secure other mounting bracket to back of unit using screws provided in bag assembly which contains flue transition.
- 5 - To support unit, secure mounting bracket to ceiling joist or truss. Unit may also be supported using support rods as shown in figure 1.

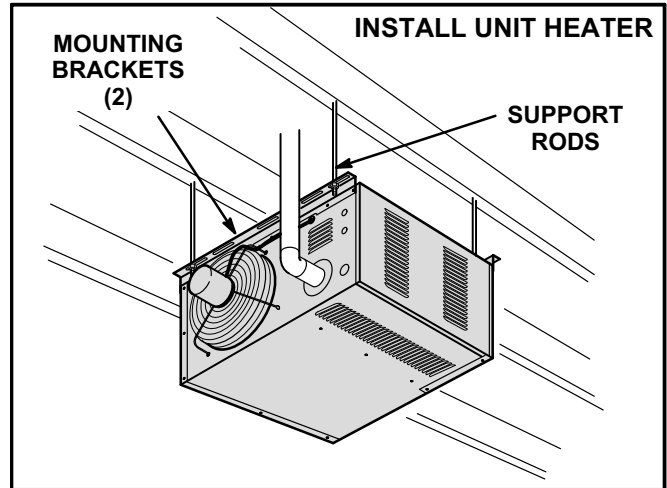

FIGURE 1

**Combustion and Ventilation Air**

Adequate facilities for supplying air for combustion and ventilation must be provided in accordance with the current edition of ANSI Z223.1, section 5.3 and CSA-B149 installation compliance codes, or applicable provisions of local building codes.

All gas-fired appliances require air to be used for combustion. In many buildings today, there is a negative indoor air pressure caused by exhaust fans, etc. If sufficient quantities of combustion air are not available, the heater or another appliance will operate in an inefficient manner, resulting in incomplete combustion which can result in the production of excessive carbon monoxide.

**⚠ CAUTION**

Insufficient combustion air can cause headaches, nausea, dizziness, asphyxiation or death.

TABLE 1  
UNIT CLEARANCES

Top		Side		Access Panel		Bottom		Back		Flue	
in	mm	in	mm	in	mm	in	mm	in	mm	in	mm
1	25	1	25	18	457	0	0	18	457	6	152

If indoor air is to be used for combustion, it must be free of the following substances or the life of the heat exchanger will be adversely affected: chlorine, carbon tetrachloride, cleaning solvent, halogen refrigerants, acids, cements and glues, printing inks, fluorides, paint removers, varnishes, or any other corrosives.

## Venting

**NOTE** - The vent is a passageway, vertical or nearly so, used to convey flue gases from an appliance, or its vent connector, to the outside atmosphere. The vent connector is the pipe or duct that connects a fuel-gas-burning appliance to a vent or chimney.

**NOTE** - Local codes may supersede any of these provisions.

### GENERAL RECOMMENDATIONS AND REQUIREMENTS

Unit heaters must be vented in compliance with the latest edition of the National Fuel Gas Code (NFPA 54 / ANSI Z223.1) in the USA and with CSA-B149.1 codes in Canada, as well as applicable provisions of local building codes, and the following instructions.

**A stamped/extruded metal transition is supplied with this certified unit. It must not be modified or altered and must be installed on the outlet of the combustion air inducer assembly prior to the installation of the vent connector. Failure to comply with this requirement will void the certification of the unit by the approval agencies.**

A single-wall vent connector may be used between the furnace and the vertical vent pipe in all applications; however, **single-wall vent material cannot be used for vertical vent piping in residential applications.**

**UL-approved Category III venting materials must be used in all residential applications which include horizontal vent piping.**

A single-wall vent pipe used as a vent connector in residential or commercial applications, or as a vertical vent in commercial applications, must have all seams and joints sealed with pressure-sensitive aluminum tape or silicone rubber sealant. Aluminum tape must meet the provisions of SMACNA AFTS-100-73 Standards. The aluminum tape must have a temperature rating of 400°F (204°C). Silicone rubber sealant must have a temperature rating of 482°F (250°C), i.e., Dow Corning RTV-736 or equivalent.

All joints must be secured with at least two corrosion-resistant screws. All joints must be checked for gas tightness after installation. Single-wall vent pipe used as vertical vent in commercial applications must not pass through any attic, interior wall, concealed space, or floor.

### VERTICAL VENTS USING METAL VENT PIPE - COMMERCIAL AND RESIDENTIAL INSTALLATIONS

These compact unit heaters are listed as Category 1 appliances for vertical vent installations.

- 1 - These unit heaters are to be used with NFPA- or ANSI-approved chimneys or U.L.-listed type B-1 gas vents, or listed chimney lining systems for gas venting where applicable, as well as the modifications and limitations listed in figure 2. Seal single-wall vent material according to **General Recommendations and Requirements** section.
- 2 - The vent connector shall be 3" (76mm) diameter on 30K and 45K Btuh units and 4" (102mm) diameter on 60K and 75K Btuh units. In all cases, a flue transition piece (supplied) is required to fit over the outlet of the induced draft assembly on the appliance.
- 3 - Keep the vent connector runs as short as possible with a minimum number of elbows. Refer to the current edition of ANSI Z223.1 or CSA-B149 installation compliance codes for maximum vent and vent connector lengths. Horizontal run of the vent connector from the combustion air inducer to the chimney/vent cannot exceed the values in table 2. Single-wall vent connector shall not be insulated.
- 4 - The entire length of a single-wall metal vent connector shall be readily accessible for inspection, cleaning and replacement.

**TABLE 2  
MAXIMUM HORIZONTAL VENT CONNECTOR  
AND HORIZONTAL VENT LENGTHS**

Number. of Elbows	Feet	Meters
1	25	7.6
2	20	6.1
3	15	4.6
4	10	3.0
5	5	1.5

## VENT TERMINATION ON SINGLE-WALL VERTICAL VENT RUNS (Commercial Applications Only)

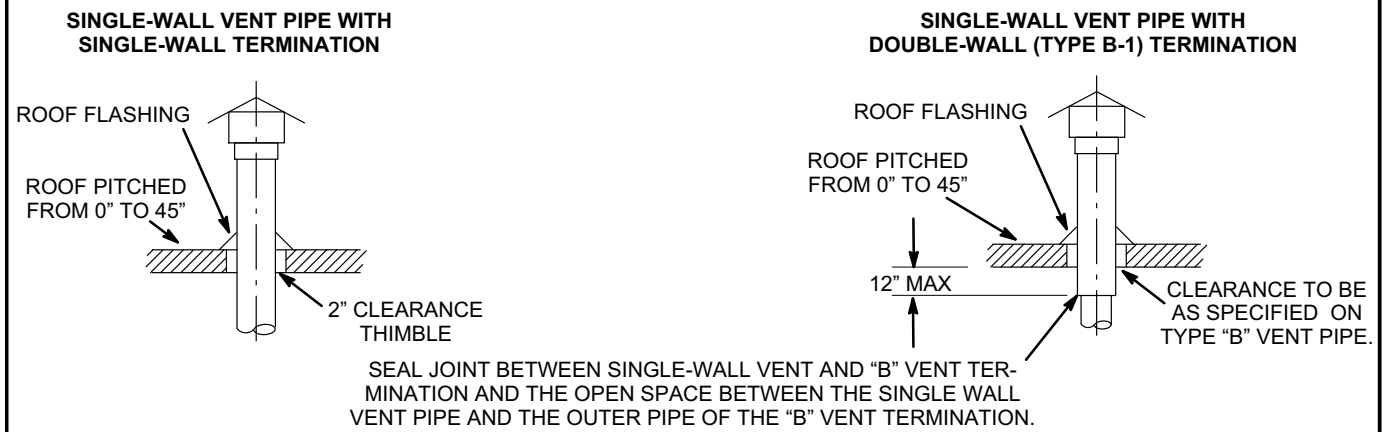

**FIGURE 2**

- 5 - The unit may be vented vertically as a single appliance or in a common vent with other gas-fired appliances. In common venting situations, vent connectors for other appliances must maintain a 4" (102mm) vertical separation between the vent connectors. Refer to common venting tables in the current editions of ANSI Z223.1 or CSA-B149 installation compliance codes for proper vent size.
- 6 - Clearance to combustible material is 6" (152mm) for single-wall vent material except where a listed clearance thimble is used. Clearance to combustible material for type B-1 vent or factory-built chimney is per manufacturer's instructions.
- 7 - The vent connector shall be supported without any dips or sags. Vertical vents shall be supported in accordance with their listing and manufacturers' instructions. All horizontal vent connector runs shall have a slope up to the vertical vent of at least 1/4" per foot (1mm per 50mm).
- 8 - All vertical type B-1 vents, single-wall vertical vents (commercial applications), or listed chimney lining systems must be terminated with a UL-listed (or other equivalent agency) vent cap or listed roof assembly.
- 9 - The vent must extend at least 3 feet (1m) above the highest point where it passes through a roof of a building. The vent must also extend at least 2 feet (1m) higher than any part of a building within a horizontal distance of 10 feet (3m) unless otherwise specified by ANSI Z223.1 or CSA-B149 installation compliance codes. The vent must extend at least 5 feet (2m) above the highest connected equipment flue collar.

## HORIZONTAL VENTING

**NOTE** - Common venting is not allowed when horizontally venting the unit heater.

If the LF24 unit heater is to be horizontally vented, a positive pressure may be created in the vent. The unit heater, when installed with horizontal venting, will perform as a category III appliance.

- 1 - **In residential applications which include horizontal venting, use only special vent materials approved for use with Category III appliances.** Refer to table 3 for venting components.
- 2 - The vent pipe diameter for horizontal installations shall be 3" (76mm) on 30K and 45K Btuh units and 4" (100mm) on 60K and 75K Btuh units. In most cases, a flue transition piece (supplied) is required to fit over the outlet of the induced draft assembly on the appliance.
- 3 - The minimum horizontal vent length is 5 feet (2m).
- 4 - Refer to table 2 for maximum horizontal vent lengths.
- 5 - If possible, do not terminate the horizontal vent through a wall that is exposed to prevailing wind. Exposure to excessive winds can affect unit performance. If such a termination is necessary, use a wind block to protect the vent termination from direct winds.
- 6 - Horizontal vent termination must be free from obstructions and at least 12" (305mm) above grade level and maximum snow height.

- 7 - Do not install a horizontal vent termination directly below roof eaves or above a public walkway, or any other area where condensate dripping may be troublesome and may cause some staining. Avoid windows where steam may cause fogging or ice buildup.
- 8 - Minimum clearance for horizontal vent termination from any door, window, gravity air inlet, gas or electric meter, regulators, and relief equipment is 4 feet (1m) for United States installations.  
In Canada, horizontal vent termination must have a minimum 6-foot horizontal clearance from gas and electric meters and relief devices.  
Refer to latest editions of the ANSI Z223.1 or CSA-B149 for installation compliance codes and with local authorities with jurisdiction.
- 9 - Vent termination must be a minimum of 4 feet (1m) below, or 4 feet (1m) horizontally, from any soffit or under-eave vent.
- 10 - Vent must be a minimum of 6 feet (2m) from an inside corner formed by two exterior walls. If possible, leave a 10-foot (3m) clearance.
- 11 - Vent termination must be a minimum of 10 feet (3m) from any forced air inlet (includes fresh air inlet for other appliances, such as a dryer).
- 12 - When termination is routed through combustible wall, vent termination must be supported using a firestop to maintain clearances specified on unit rating plate. Inside edge of vent termination must be at least 12" (305mm) from outside wall.

- 13 - All horizontal vents which use special vent pipe for use with Category III appliances must terminate with an approved Category III tee. Opening end must face downward.
- 14 - For horizontal venting, the vent pipe shall be supported with hangers no more than 3 feet (1m) apart to prevent movement after installation.
- 15 - Select a wall termination point that will maintain 1/4" (6mm) rise per foot (305mm) slope of horizontal run of vent pipe.
- 16 - For upward sloped vent, a condensate tee and drain must be installed within the first 5 feet (2m) from the unit heater to protect the appliance. If a flexible condensate drain line is used, the drain line must include a loop filled with water to prevent combustion products from entering the structure. If the unit is shut down for an extended period of time and will be exposed to sub-freezing temperatures, the condensate may freeze.
- 17 - Select a wall termination point that will maintain 1/4" rise per foot slope of horizontal run of vent pipe. In areas where authorities having jurisdiction permit, a downward slope of maximum 1/4" per foot is also acceptable. Condensate drainage can be collected in a tee pipe section (figure 4) with drain loop similar to one used for upward slope vent, or allowed to drip through the vent termination, if permitted by authorities (figure 5).

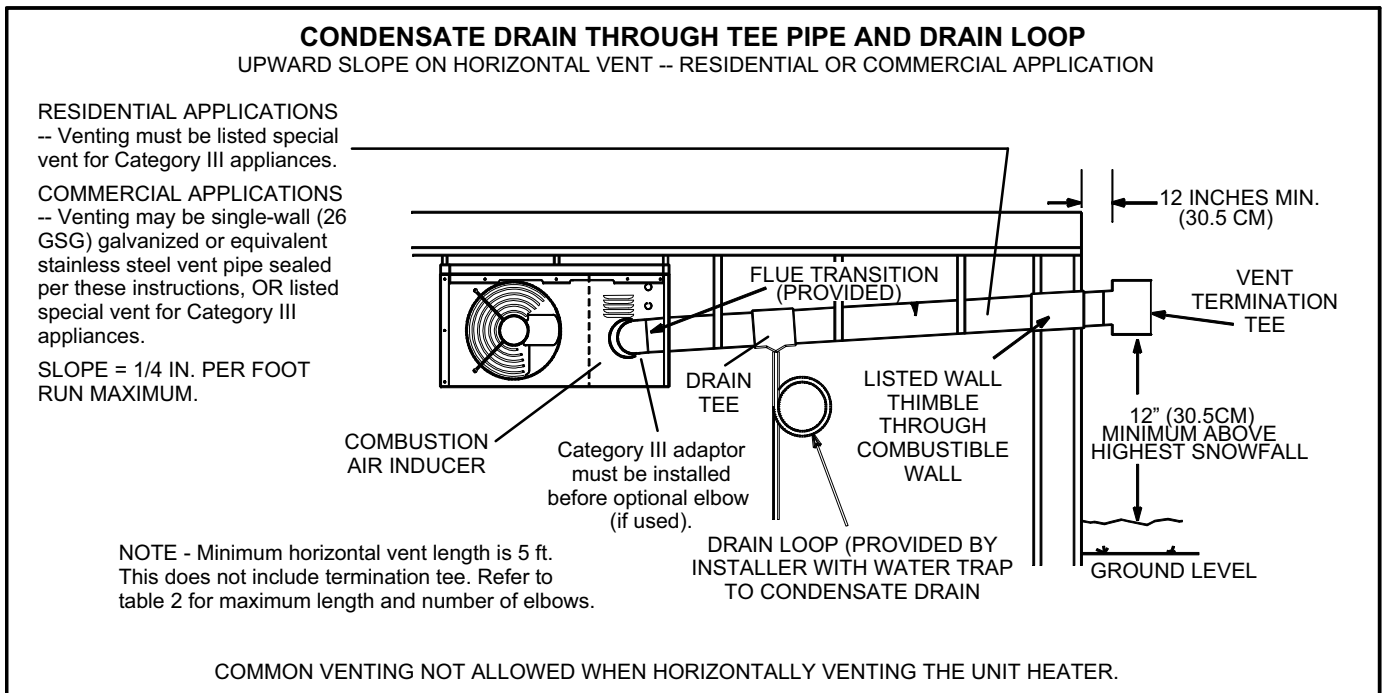

**FIGURE 3**

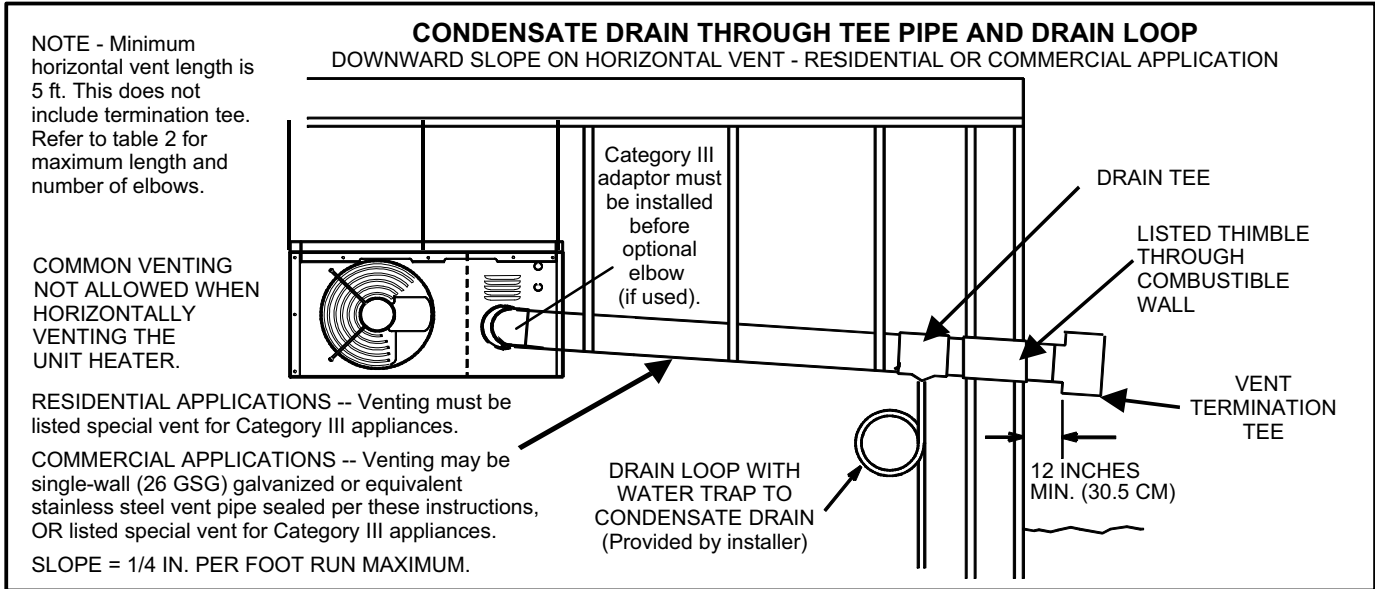

**FIGURE 4**

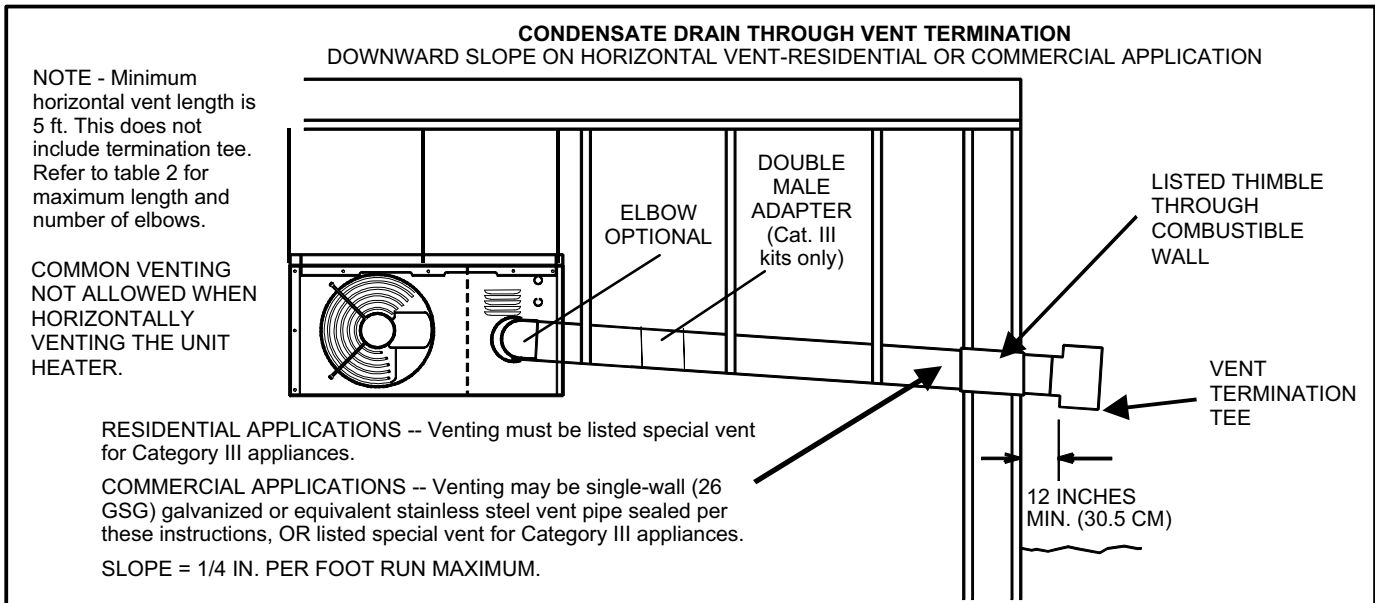

**FIGURE 5**

**TABLE 3**  
**Category III Horizontal Venting Components**  
**(Required for Horizontal Vent Applications)**

Unit	Catalog Number	Model Number	Description
LF24-30 LF24-45	75W66	C5VENT3KD	3" downward sloped Cat III vent kit
	75W62	C5VENT3KU	3" upward sloped Cat III vent kit
	75W70	C5VENT3E	3" 90° elbow Cat III (optional)
	75W74	C5VENT3P6	3" straight pipe (length = 6")
	75W75	C5VENT3P12	3" straight pipe (length = 12")
	75W76	C5VENT3P36	3" straight pipe (length = 36")
LF24-60 LF24-75	75W63	C5VENT4KU	4" upward sloped Cat III vent kit
	75W67	C5VENT4KD	4" downward sloped Cat III vent kit
	75W71	C5VENT4E	4" 90° elbow Cat III (optional)
	75W77	C5VENT4P6	4" straight pipe (length = 6")
	75W78	C5VENT4P6	4" straight pipe (length = 12")
	75W79	C5VENT4P6	4" straight pipe (length = 36")



## VENTING USING A MASONRY CHIMNEY

The following additional requirements apply when a lined masonry chimney is being used to vent the compact unit heater.

### **⚠ IMPORTANT**

**Single appliance venting of a fan-assisted unit heater into a tile lined masonry chimney (interior or outside wall) is prohibited. The chimney must first be lined with either type "B-1" vent or an insulated single-wall flexible vent lining system, sized in accordance with venting tables in the ANSI Z223.1, or CSA-B149 installation compliance codes.**

- 1 - Masonry chimneys used to vent Category I units heaters must be either tile-lined or lined with a listed metal lining system or dedicated gas vent. Unlined masonry chimneys are prohibited. A category I appliance must never be connected to a chimney that is servicing a solid fuel appliance. If a fireplace chimney flue is used to vent this appliance, the fireplace opening must be permanently sealed.
- 2 - A fan-assisted unit heater may be commonly vented into an existing lined masonry chimney provided:
  - a. The chimney is currently serving at least one draft-hood equipped appliance.
  - b. The vent connector and chimney are sized in accordance with venting tables.
- 3 - A "B1" double-wall vent or masonry chimney liner shall terminate above the roof surface with a listed cap or a listed roof assembly in accordance with the terms of their respective listings and the vent manufacturer's instructions.
- 4 - Do not install a manual damper, barometric draft regulator, or flue restrictor between the unit heater and the chimney.
- 5 - If type "B1" double-wall vent is used inside a chimney, no other appliance can be vented into the chimney. Outer wall of type "B" vent pipe must not be exposed to flue products.
- 6 - Insulation for the flexible vent pipe must be an encapsulated fiberglass sleeve recommended by the flexible vent pipe manufacturer.
- 7 - The space between liner and chimney wall should **NOT** be insulated with puffed mica or any other loose granular insulating material.
- 8 - If B-1 vent or an insulated flexible vent pipe cannot be used as liners, the chimney must be rebuilt to accommodate one of these methods or some alternate approved method must be found to vent the appliance. When inspection reveals that an existing chimney is not safe for the intended purpose, it shall be rebuilt to conform to nationally recognized standards, lined or relined with suitable materials or replaced with a gas vent or chimney suitable for venting unit heaters. The chimney passageway must be checked periodically to ensure that it is clear and free of obstructions.

## REMOVAL OF UNIT FROM COMMON VENT

In the event that an existing unit heater is removed from a venting system commonly run with separate gas appliances, the venting system is likely to be too large to properly vent the remaining attached appliances. The following test should be conducted while each appliance is in operation and the other appliances are not in operation, yet remain connected to the common venting system. If the venting system has been installed improperly, the system must be corrected.

- 1 - Seal any unused openings in the common venting system.
- 2 - Visually inspect the venting system for proper size and horizontal pitch. Determine there is no blockage or restriction, leakage, corrosion, or other deficiencies which could cause an unsafe condition.
- 3 - In so far as is practical, close all building doors and windows and all doors between the space in which the appliances remaining connected to the common venting system are located and other spaces of the building. Turn on clothes dryers and any appliances not connected to the common venting system. Turn on any exhaust fans, such as range hoods and bathroom exhausts, so they will operate at maximum speed. Do not operate a summer exhaust fan. Close fireplace dampers.
- 4 - Follow the lighting instructions. Place the appliance being inspected in operation. Adjust thermostat so appliance will operate continuously.
- 5 - Test for spillage at the draft hood relief opening after five minutes of main burner operation. Use the flame of a match or candle, or smoke from a cigarette, cigar, or pipe.
- 6 - After it has been determined that each appliance remaining connected to the common venting system properly vents when tested as outlined above, return doors, windows, exhaust fans, fireplace dampers and any other gas-burning appliance to their previous condition of use.
- 7 - If improper venting is observed during any of the above tests, the common venting system must be corrected. The common venting system should be resized to approach the minimum size as determined by using the appropriate tables in Appendix G in the current editions of the ANSI Z223-1, or the appropriate Category I Natural Gas and Propane appliances venting sizing tables in the current standards of the CSA-B149 for installation compliance codes.

## Electrical Connections

**NOTE** - Local codes may supersede any of the provisions outlined in this instruction.

The LF24 series unit heaters use a direct spark ignition system. There is no pilot necessary as the spark lights the main burner as the gas valve is turned on. The direct spark ignition control board emits radio noise as the sparking process is under way. The level of energy may be sufficient to disturb a logic circuit in a microprocessor controlled thermostat. It is recommended that an isolation relay be used when connecting the unit heaters to a microprocessor controlled thermostat. Install the thermostat according to instructions provided. Install a separate fused disconnect switch, with the fuse sized according to blower motor size. Connect wiring through knockout on the junction box located on the side of the unit heater. Refer to heater wiring diagram for connection information. Use 18 gauge wire or larger for thermostat connections.

**NOTE** - Electrically ground unit in accordance with local codes or, in the absence of local codes, in accordance with the current editions of the ANSI/NFPA No. 70, National Electrical Code or CSA C22.1, Canadian Electrical Code, Part 1.

**NOTE** - Uninsulated ground wires must be wrapped in electrical tape to avoid damage to the electrical system.

Make line voltage connections as shown in figure 7. Connect field wiring as shown on wiring diagram on unit. Also refer to typical diagram in this manual. An additional thermostat wire must be run to terminal "G" on heater when continuous blower is desired.

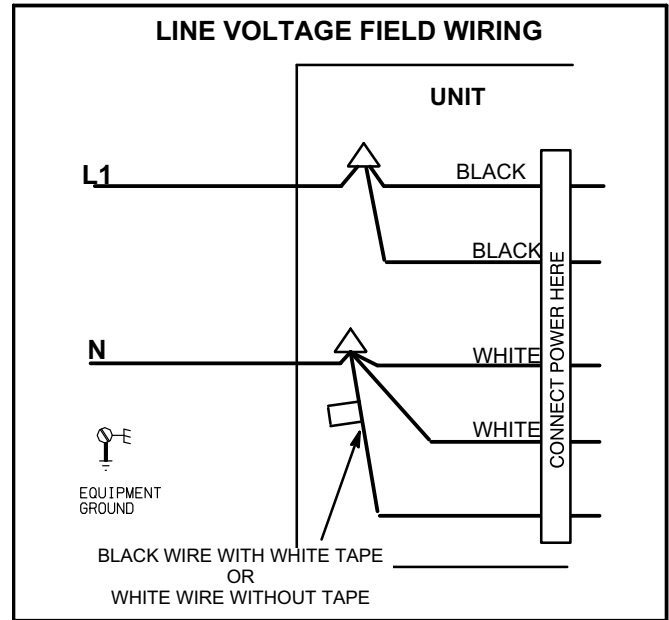

FIGURE 7

## TYPICAL LF24-30, 45, 60, & 75 WIRING SCHEMATIC

- ⚠ MAXIMUM LOAD NOT TO EXCEED  
20VA AT 24V, CLASS 2
- ⚠ FSA, LF24-30, 45 HAVE  
(1) S47 ROLLOUT SWITCH.  
FSA, LF24-60, 75 HAVE (2)  
S47 ROLLOUT SWITCHES.
- ⚠ DL36 IS A FIELD OPTION FOR  
MANIFOLD PURGE

DISCONNECT ALL POWER  
BEFORE SERVICING.

KEY	DESCRIPTION
A3	CONTROL-BURNER, IGNITION
B3	MOTOR- BLOWER
B6	MOTOR-COMBUSTION AIR INDUCER
C4	CAPACITOR-BLOWER MOTOR 1
DL36	RELAY-DELAY
GV1	VALVE- GAS
S10	LIMIT- PRIMARY, GAS
S18	SWITCH-COMB. AIR BLWR PROVE
S47	SWITCH-FLAME ROLLOUT
T1	TRANSFORMER- CONTROL

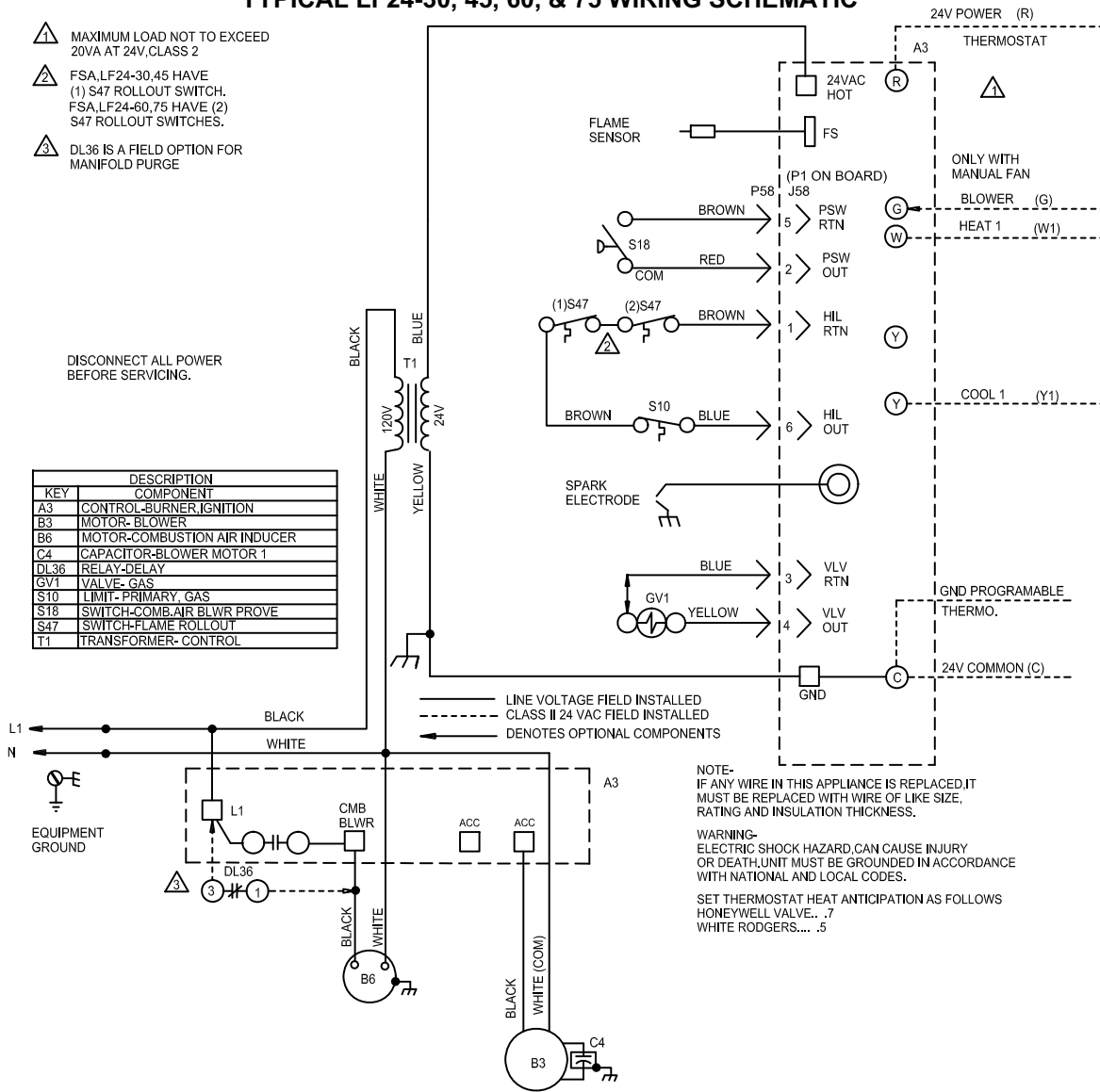

### Gas Connection

When connecting gas supply, the length of the run from the meter must be considered in determining the pipe size to avoid excessive pressure drop. A line pressure of 7" w.g. (178mm w.g.) for natural gas should be maintained when sizing piping. For correct sizing of piping, consult the utility having jurisdiction.

A drip leg should be installed in the vertical pipe run to the unit. In some localities, codes may require that a manual main shutoff valve and union (furnished by installer) be installed external to the unit. Union must be of the ground joint type. A drip leg should be readily accessible to permit cleaning and emptying. See figure 8.

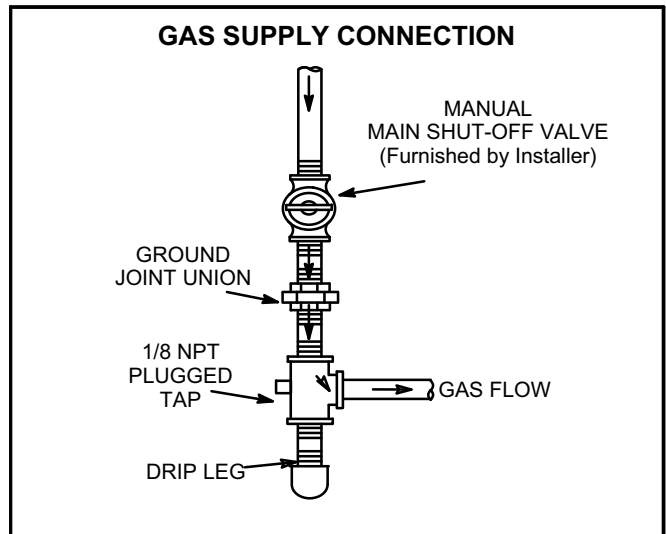

**FIGURE 8**

**NOTE** - If a switch box is mounted over electrical knock-outs on back of unit, leave a minimum of 4" (102mm) clearance between switch box and drip leg.

A 1/8" NPT plugged tap shall be installed immediately upstream of the gas supply connection to the heater.

**NOTE** - Compounds used on threaded joints of gas piping must be resistant to the actions of liquefied petroleum gases.

**Leak Check**

After gas piping is completed, carefully check all piping connections, (field and factory), for gas leaks. Use a soap solution or other preferred means.

**⚠ CAUTION**  
**DO NOT use matches, candles, flame or other sources of ignition to check for gas leaks.**

The appliance must be isolated from the gas supply piping system by closing its individual manual gas shutoff valve during any pressure testing of the gas supply system at test pressures equal to or less than 1/2 psig (3.45kPa).

**⚠ IMPORTANT**  
**The heater and its individual shut off valve must be disconnected from the gas supply piping system during any pressure testing of that system at test pressures in excess of 1/2 psig (3.45kPa). See figure 9.**

**NOTE** - In case emergency shutdown is required, shut down main gas valve and disconnect main power to unit. These devices should be properly labeled by the installer.

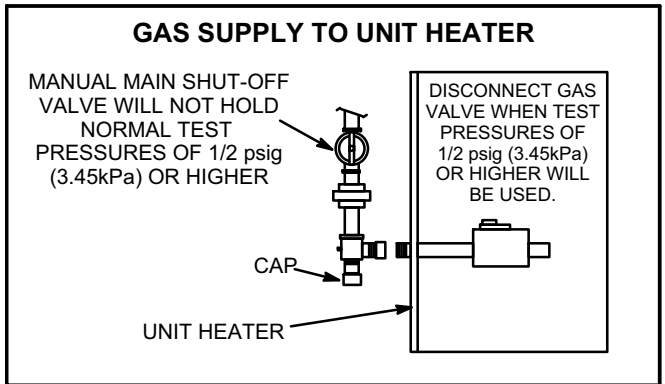

**FIGURE 9**

**Unit Start-Up**

FOR YOUR SAFETY READ BEFORE LIGHTING

**⚠ WARNING**  
**Electric shock hazard. Can cause injury or death. Do not use this heater if any part has been under water. Immediately call a qualified service technician to inspect the furnace and to replace any part of the control system and any gas control which has been under water.**

**⚠ WARNING**  
**Danger of explosion. Can cause injury or product or property damage. If overheating occurs or if gas supply fails to shut off, shut off the manual gas valve to the appliance before shutting off electrical supply.**

**⚠ WARNING**  
**Electric shock hazard. Can cause injury or death. Before attempting to perform any service or maintenance, turn the electrical power to unit OFF at disconnect switch(es). Unit may have multiple power supplies.**

**⚠ WARNING**  
**Danger of explosion and fire. Can cause injury or product or property damage. You must follow these instructions exactly.**

BEFORE LIGHTING smell all around the appliance area for gas. Be sure to smell next to the floor because some gas is heavier than air and will settle on the floor.

Use only your hand to push in or turn the gas control knob. Never use tools. If the knob will not push in or turn by hand, do not try to repair it, call a qualified service technician. Force or attempted repair may result in a fire or explosion.

These unit heaters are equipped with an automatic spark ignition system. There is no pilot. In case of a safety shutdown, move thermostat switch to **OFF**, then return the thermostat switch to **HEAT** position.

LF24 unit heaters are equipped with an automatic spark ignition system. There is no pilot. In case of a safety shutdown, move thermostat switch to **OFF**, then return the thermostat switch to **HEAT** position.

## OPERATION OF HONEYWELL VR8205 SERIES GAS VALVE (FIGURE 10)

**NOTE - STOP!** Read the safety information at the beginning of this section.

- 1 - Set thermostat to lowest setting.

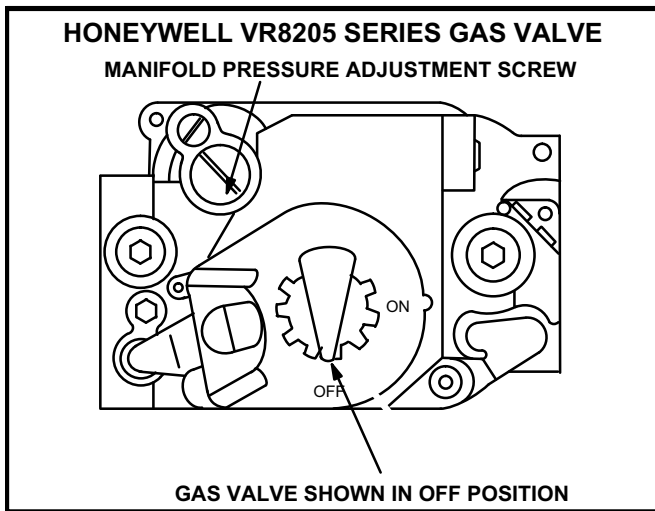



FIGURE 10

- 2 - Turn off all electrical power to appliance.
- 3 - This appliance is equipped with an ignition device which automatically lights burners. **DO NOT attempt to light the burners manually.**
- 4 - Turn the manual knob on gas valve clockwise to **OFF**. Do not force.
- 5 - Wait five minutes to clear out any gas. If you then smell gas, **STOP!** Immediately call your gas supplier from a neighbor's phone. Follow the gas supplier's instructions. If you do not smell gas, go to next step.
- 6 - Turn manual knob on gas valve counterclockwise to **ON**.
- 7 - Turn on all electric power to unit.
- 8 - Set thermostat to desired setting.
- 9 - The combustion air inducer (CAI) will start. The burners will light within 40 seconds.
- 10 - If unit does not light first time (gas line not fully purged) it will attempt up to two more ignitions before locking out.
- 11 - If lockout occurs, repeat steps 1 through 9.
- 12 - If appliance still will not operate, follow the instructions "**To Turn Off Gas to Unit**" and call your service technician or gas supplier.

### To Turn Off Gas to Unit

- 1 - Set thermostat to lowest level.
- 2 - Turn off all electrical power to unit if service is to be performed.
- 3 - Turn knob on gas valve 90° clockwise  to **OFF**.

### Heating Sequence of Operation

- 1 - When the thermostat calls for heat, the combustion air inducer starts immediately.
- 2 - Combustion air pressure switch proves inducer operation before allowing power to the ignition controller. This switch is factory set and no adjustment is necessary.
- 3 - After pre-purge of approximately 30 seconds, the spark ignition is energized and the solenoid valves open in the gas valve.
- 4 - The spark then ignites the gas, the ignition sensor proves the flame and the combustion process continues.
- 5 - In the event that the flame is not detected after the first 10-second trial for ignition, the controller will repeat steps 3 and 4 an additional two times before locking out the gas valve. Ignition control will then automatically repeat steps 3, 4, and 5 after 60 minutes.  
*NOTE - To interrupt the 60-minute lockout period, move thermostat from "Heat" to "OFF" then back to "Heat." Heating sequence then restarts at step 1.*
- 6 - The burners must light without noticeable crossover delay. There must be no flame lifting from the burner heads, flashback or burning within the burner. The flames should be predominantly blue in color and should be approximately centered in the tubes with no apparent impingement taking place.
- 7 - The ignition control will energize the fan approximately 45 seconds after ignition is established.
- 8 - After the thermostat demand is satisfied the gas valve is closed. Five seconds after the demand is satisfied, the combustion air inducer is shut off.
- 9 - The ignition control will shut off the system fan approximately 150 seconds after the gas valve is de-energized.

## Ignition Control LED

The ignition control contains a green LED which indicates the following:

**TABLE 4  
IGNITION CONTROL LED**

LED	UNIT OPERATION
Slow. Flash*	Normal Operation - No call for heat
Fast Flash	Normal Operation - Call for heat
2 Flashes	System lockout - failed to detect or sustain flame
3 Flashes	Pressure switch failed closed before CAI is energized or failed open after CAI is energized
4 Flashes	High limit or rollout switch open
5 Flashes	Flame sensed and gas valve not energized
Steady Off	Loss of Power
Steady On	Ignition control failure

\*When thermostat is placed in continuous fan mode LED will slowly flash.

## High Altitude Adjustments

Units may be fired at full input up to 2000 feet. (610m) above sea level. Above 2000 feet (610m), manifold pressure must be adjusted on some units. Adjust pressure regulator to pressure shown in table 5 for natural gas and table 6 for LP/propane gas.

**TABLE 5  
NATURAL GAS MANIFOLD PRESSURES  
[inch w.g. (kPa)]**

INPUT (BTUH)	Altitude in Feet (Meters)				
	0-3500 (0-1067)	35-4500 (1067-1372)	45-5500 (1372-1676)	55-6500 (1676-1981)	65-7500 (1981-2286)
30	3.5 (0.87)*	3.5 (0.87)*	3.5 (0.87)*	3.5 (0.87)*	3.5 (0.87)*
45	3.5 (0.87)*	3.5 (0.87)*	3.5 (0.87)*	3.5 (0.87)*	3.4 (0.85)
60	3.5 (0.87)*	3.5 (0.87)*	3.5 (0.87)*	3.5 (0.87)*	3.5 (0.87)*
75	3.5 (0.87)*	3.4 (0.85)	3.3 (0.82)	3.2 (0.80)	3.1 (0.77)

\*No adjustment required.

**TABLE 6  
LP/PROPANE GAS MANIFOLD PRESSURES  
[inch w.g. (kPa)]**

INPUT (BTUH)	Altitude in Feet (Meters)				
	0-3500 (0-1067)	3501 - 4500 (1067-1372)	4501 - 5500 (1372-1676)	5501 - 6500 (1676-1981)	6501 - 7500 (1981-2286)
30	9.5 (2.37)*	9.5 (2.37)*	9.5 (2.37)*	9.5 (2.37)*	9.5 (2.37)*
45	9.5 (2.37)*	9.5 (2.37)*	9.5 (2.37)*	9.5 (2.37)*	9.2 (2.28)
60	9.5 (2.37)*	9.5 (2.37)*	9.5 (2.37)*	9.5 (2.37)*	9.5 (2.37)*
75	9.5 (2.37)*	9.2 (2.28)	8.9 (2.21)	8.6 (2.13)	8.3 (2.06)

\*No adjustment required.

**NOTE - A natural to LP/propane gas changeover kit is required to convert unit. Refer to the installation instructions supplied with the changeover kit for conversion procedure.**

If unit is installed at an altitude greater than 7500 feet (1372m), unit must be derated by four percent for each additional 1000 feet (305m) above 7500 feet or as specified by local authority having jurisdiction.

The combustion air inducer proving switch is factory set. No adjustment is necessary.

## Gas Flow

To check for proper gas flow to the combustion chamber, determine the Btu input from the appliance rating plate. Divide this input rating by the Btu per cubic feet of available gas. Result is the required number of cubic feet per hour. Determine the flow of gas through the gas meter for two minutes and multiply by 30 to get the hourly flow of gas.

## Gas Pressure Adjustment

- 1 - Check gas line pressure with unit firing at maximum rate. A minimum of 5" (127mm) w.g. for natural gas or 10.4" (264mm) w.g. for LP/propane gas should be maintained for proper unit operation.
- 2 - After line pressure has been checked and adjusted, check regulator pressure. Correct manifold pressure is shown on the unit rating plate. See figures 9 and 10 for gas pressure adjustment screw location. A natural gas to LP/propane gas changeover kit is required to convert the unit in the field. Refer to installation instructions provided with changeover kit for conversion procedure.

## Limit Control

The limit control switch is factory-set and is not field-adjustable.

## Louver Vane Adjustment

Rotate louver vanes to direct airflow upward, downward, straight, or any combination of these directions. When unit is installed in an inverted position, louvers may be positioned in the same manner.

## Combustion Air Pressure Switch

This pressure switch checks for proper combustion air inducer operation before allowing an ignition trial. The switch is factory-set. No field adjustment is necessary.

## Flame Rollout Switch

The flame rollout switch(es) are located on the burner box top, behind the ignition control board. This normally closed switch opens on a temperature rise. Check for adequate combustion air before manually resetting switch.

## Service

### CAUTION

**Turn off gas and electrical power to unit before performing any maintenance or service operations on this unit. Remember to follow lighting instructions when putting unit back into operation after service or maintenance.**

The unit heater and vent system shall be inspected once a year by a licensed professional service technician, or equivalent.

## BURNERS

- 1 - Periodically examine burner flames for proper appearance during the heating season.
- 2 - Before each heating season examine the burners for any deposits or blockage that may have occurred.
- 3 - Clean burners as follows:
  - a - Turn off both electrical and gas supplies to unit.
  - b - Disconnect gas supply piping, high tension and sensor leads. Remove gas manifold. Remove burner tray.

- c - Clean burners as necessary. Make sure that burner heads line up properly to ensure flame crossover. Check spark gap on electrode and adjust if required. The gap should be between 0.110" and 0.140" (3mm to 4mm). The gap may be checked with appropriately sized twist drills or feeler gauges.
- d - Reinstall burner tray, gas manifold, high tension and sensor leads. Reconnect gas supply piping.
- e - Restore electrical power and gas supply. Follow lighting instructions to light unit. Check burner flame.

## FLUE PASSAGEWAY AND FLUE BOX

The flue passages and flue box should be inspected and cleaned prior to each heating season. The sequence of operation should be as follows:

- 1 - Turn off both electrical and gas supply to unit.
- 2 - Disconnect combustion air inducer wiring.
- 3 - Remove screws securing flue box to unit. Remove flue box. If necessary, remove inducer assembly from flue box. Clean flue box with wire brush.
- 4 - Remove turbulator retention bracket and turbulators. Clean turbulators with wire brush.
- 5 - Remove burners as described in "Burners" section.
- 6 - Clean tubes with a wire brush.
- 7 - Reassemble unit. The combustion air and flue box gaskets should also be replaced during reassembly.
- 8 - Restore electrical power and gas supply. Follow lighting instructions to light unit. Check operation of unit.

## COMBUSTION AIR INDUCER

Under normal operating conditions, the combustion air inducer should be checked and cleaned prior to the heating season with the power supply disconnected. Use a small brush to clean inducer wheel.

## ELECTRICAL

- 1 - Check all wiring for loose connections.
- 2 - Check for correct voltage at unit (unit operating).
- 3 - Check amperage draw.

## FLUE AND CHIMNEY

Check all vent and vent connector joints for tightness. Ensure that connections are sealed and that there are no blockages.

## FAILURE TO OPERATE

If unit fails to operate check the following:

- 1 - Is thermostat calling for heat?
- 2 - Is main disconnect closed?
- 3 - Is there a breaker tripped or a fuse blown?
- 4 - Is gas turned on at meter?
- 5 - Is manual shutoff valve open?
- 6 - Is unit ignition system in lock out? If unit locks out again, call service technician to inspect unit.
- 7 - Is pressure switch closed? Obstructed flue will cause unit to shut off at pressure switch. Check flue passage and outlet.

**SAFETY SHUT-OFF VALVE TEST**

The safety shut-off valve test procedure is as follows:

- 1 - Turn off the manual gas valve.
- 2 - Set the thermostat to call for heat.
- 3 - System begins normal sequence of operation.
- 4 - After approximately 30 seconds (pre purge period) the LED will fast flash indicating the gas valve is powered.

- 5 - After 10 seconds, the gas valve closes and steps 4 and 5 will repeat two additional times before locking out the gas valve, which will be indicated by two flashes on the LED.
- 6 - To restart the system, de-energize the thermostat call for heat and follow the operating instructions under "Unit Start-Up and Operation."

**REPAIR PARTS**

When ordering repair parts, include the complete unit model number listed on the unit rating plate. For example: LF24-45A-1. Contact the installing dealer, or visit [www.lennox.com](http://www.lennox.com) or call 1-800-9LENNOX for a list of the Lennox dealers in the area.

**START-UP AND PERFORMANCE CHECKLIST**

Job Name: \_\_\_\_\_ Job No.: \_\_\_\_\_ Date: \_\_\_\_\_  
 Job Location: \_\_\_\_\_ City: \_\_\_\_\_ State/Province: \_\_\_\_\_  
 Installer: \_\_\_\_\_ City: \_\_\_\_\_ State/Province: \_\_\_\_\_  
 Unit Model No.: \_\_\_\_\_ Serial No.: \_\_\_\_\_ Service Technician: \_\_\_\_\_

Electrical Connections Tight? \_\_\_\_\_ Air Shutters Properly Adjusted (If Installed)? \_\_\_\_\_  
 Supply Voltage \_\_\_\_\_ Flue Connections Tight? \_\_\_\_\_  
 Blower Motor Lubrication O.K.? \_\_\_\_\_ Fan Timer Operation Checked? \_\_\_\_\_  
 Gas Piping Connections Tight & Leak-Tested? \_\_\_\_\_  
 Blower Motor Amps \_\_\_\_\_  
 Furnace Btu Input \_\_\_\_\_  
 Line Pressure \_\_\_\_\_  
 Manifold Pressure \_\_\_\_\_ w.c.

**THERMOSTAT**

Calibrated? \_\_\_\_\_  
 Heat Anticipator Properly Set? \_\_\_\_\_  
 Level? \_\_\_\_\_